



22777 Springwoods Village Parkway  
Spring, Texas 77389  
(832) 625-0104

August 31, 2020

Kirby Olson  
New Mexico Environment Department  
Air Quality Bureau  
525 Camino de los Marquez, Suite 1  
Santa Fe, New Mexico, 87505

**RE: Application for NSR Modification  
Bulldog Compressor Station NSR Permit No. 8153  
XTO Energy Inc.**

Dear Ms. Olson:

XTO Energy Inc. is submitting the attached New Source Review permit application for the referenced facility. A detailed list of proposed changes are included in Section 3 of the application. Also included is a check for the filing fee. The electronic files will be provided via email or secure transfer. Please contact me at 832-624-2768 or [benjamin\\_schneider@xtoenergy.com](mailto:benjamin_schneider@xtoenergy.com) should you have any questions.

Sincerely,

A handwritten signature in blue ink that reads 'Benjamin Schneider'.

Benjamin Schneider, P.E.  
Environmental Engineer



**BULLDOG COMPRESSOR STATION**

**Eddy County, NM**

**NSR Permit Modification Application**



**PREPARED BY:**

**BEN SCHNEIDER**

**ENVIRONMENTAL ENGINEER**

**XTO ENERGY INC.**

**8/31/2020**

**BULLDOG COMPRESSOR STATION**  
**NSR Permit Modification Application**

**Table of Contents**

Tab 1	UA1 Form - Company and Facility Information
Tab 2	UA2 Form - Application Tables
Tab 3	Section 3 - Application Summary
Tab 4	Section 4 - Process Flow Sheet
Tab 5	Section 5 - Plot Plan Drawn To Scale
Tab 6	Section 6 - All Calculations
Tab 7	Section 7 - Information Used To Determine Emissions
Tab 8	Section 8 - Map(s)
Tab 9	Section 9 - Proof of Public Notice
Tab 10	Section 10 - Written Description of the Routine Operations of the Facility
Tab 11	Section 11 -Source Determination
Tab 12	Section 12 - PSD Applicability Determination for All Sources
Tab 13	Section 13 - Determination of State & Federal Air Quality Regulations
Tab 14	Section 14 - Operational Plan to Mitigate Emissions
Tab 15	Section 15 - Alternative Operating Scenarios
Tab 16	Section 16 - Air Dispersion Modeling
Tab 17	Section 17 - Compliance Test History
Tab 18	Section 18 - Addendum for Streamline Applications (Not Applicable)
Tab 19	Section 19 - Requirements for Title V Program
Tab 20	Section 20 - Other Relevant Information
Tab 21	Section 21 - Addendum for Landfill Applications (Not Applicable)
Tab 22	Section 22 - Certification
Tab 23	Section 23 - UA4

**Tab 1**

**UA1 Form - Company and Facility Information**

<p><b>Mail Application To:</b></p> <p>New Mexico Environment Department                  Air Quality Bureau                  Permits Section                  525 Camino de los Marquez, Suite 1                  Santa Fe, New Mexico, 87505</p> <p>Phone: (505) 476-4300                  Fax: (505) 476-4375                  www.env.nm.gov/aqb</p>		<p><b>For Department use only:</b></p>       <p>AIRS No.:</p>
---	--	--

## Universal Air Quality Permit Application

**Use this application for NOI, NSR, or Title V sources.**

Use this application for: the initial application, modifications, technical revisions, and renewals. For technical revisions, complete Sections, 1-A, 1-B, 2-E, 3, 9 and any other sections that are relevant to the requested action; coordination with the Air Quality Bureau permit staff prior to submittal is encouraged to clarify submittal requirements and to determine if more or less than these sections of the application are needed. Use this application for streamline permits as well. See Section 1-I for submittal instructions for other permits.

**This application is submitted as** (check all that apply):  Request for a No Permit Required Determination (no fee)

**Updating** an application currently under NMED review. Include this page and all pages that are being updated (no fee required).

Construction Status:  Not Constructed  Existing Permitted (or NOI) Facility  Existing Non-permitted (or NOI) Facility

Minor Source:  a NOI 20.2.73 NMAC  20.2.72 NMAC application or revision  20.2.72.300 NMAC Streamline application

Title V Source:  Title V (new)  Title V renewal  TV minor mod.  TV significant mod. TV Acid Rain:  New  Renewal

PSD Major Source:  PSD major source (new)  minor modification to a PSD source  a PSD major modification

**Acknowledgements:**

I acknowledge that a pre-application meeting is available to me upon request.  Title V Operating, Title IV Acid Rain, and NPR applications have no fees.

\$500 NSR application Filing Fee enclosed **OR**  The full permit fee associated with 10 fee points (required w/ streamline applications).

Check No.: 2500132873 in the amount of \$500

I acknowledge the required submittal format for the hard copy application is printed double sided 'head-to-toe', 2-hole punched (except the Sect. 2 landscape tables is printed 'head-to-head'), numbered tab separators. Incl. a copy of the check on a separate page.

This facility qualifies to receive assistance from the Small Business Environmental Assistance program (SBEAP) and qualifies for 50% of the normal application and permit fees. Enclosed is a check for 50% of the normal application fee which will be verified with the Small Business Certification Form for your company.

This facility qualifies to receive assistance from the Small Business Environmental Assistance Program (SBEAP) but does not qualify for 50% of the normal application and permit fees. To see if you qualify for SBEAP assistance and for the small business certification form go to [https://www.env.nm.gov/aqb/sbap/small\\_business\\_criteria.html](https://www.env.nm.gov/aqb/sbap/small_business_criteria.html) ).

**Citation:** Please provide the **low level citation** under which this application is being submitted: **20.2.72.219.B.1.d NMAC** (e.g. application for a new minor source would be 20.2.72.200.A NMAC, one example for a Technical Permit Revision is 20.2.72.219.B.1.b NMAC, a Title V acid rain application would be: 20.2.70.200.C NMAC)

## Section 1 – Facility Information

<b>Section 1-A: Company Information</b>		AI # if known (see 1 <sup>st</sup> 3 to 5 #s of permit IDEA ID No.): 38798	Updating Permit/NOI #: 8153
1	Facility Name: Bulldog Compressor Station	Plant primary SIC Code (4 digits): 1311	
		Plant NAIC code (6 digits): 211120	
a	Facility Street Address (If no facility street address, provide directions from a prominent landmark): See 1-D.4.		
2	Plant Operator Company Name: XTO Energy Inc.	Phone/Fax: (832) 624-4426	
a	Plant Operator Address: 22777 Springwoods Village Parkway, W4.6B.374, Spring, TX 77389		
b	Plant Operator's New Mexico Corporate ID or Tax ID: 1522747		

3	Plant Operator Company Name: XTO Energy Inc.	Phone/Fax: (832) 624-4426
a	Plant Owner(s) Mailing Address(s): 22777 Springwoods Village Parkway, W4.6B.374, Spring, TX 77389	
4	Bill To (Company): XTO Energy Inc.	Phone/Fax: (832) 624-4426
a	Mailing Address: 22777 Springwoods Village Parkway, W4.6B.374, Spring, TX 77389	E-mail: Benjamin_Schneider@xtoenergy.com
5	<input checked="" type="checkbox"/> Preparer: Benjamin_Schneider@xtoenergy.com <input type="checkbox"/> Consultant:	Phone/Fax: (832) 624-2768
a	Mailing Address: 22777 Springwoods Village Parkway, W4.6B.374, Spring, TX 77389	E-mail: Benjamin_Schneider@xtoenergy.com
6	Plant Operator Contact: Benjamin Schneider	Phone/Fax: (832) 624-2768
a	Mailing Address: 22777 Springwoods Village Parkway, W4.6B.374, Spring, TX 77389	E-mail: Benjamin_Schneider@xtoenergy.com
7	Air Permit Contact: Benjamin Schneider	Title: Environmental Engineer
a	E-mail: Benjamin_Schneider@xtoenergy.com	Phone/Fax: (832) 624-2768
b	Mailing Address: 22777 Springwoods Village Parkway, W4.6B.374, Spring, TX 77389	
c	The designated Air permit Contact will receive all official correspondence (i.e. letters, permits) from the Air Quality Bureau.	

### Section 1-B: Current Facility Status

1.a	Has this facility already been constructed? <input checked="" type="checkbox"/> Yes <input type="checkbox"/> No	1.b If yes to question 1.a, is it currently operating in New Mexico? <input checked="" type="checkbox"/> Yes <input type="checkbox"/> No
2	If yes to question 1.a, was the existing facility subject to a Notice of Intent (NOI) (20.2.73 NMAC) before submittal of this application? <input type="checkbox"/> Yes <input checked="" type="checkbox"/> No	If yes to question 1.a, was the existing facility subject to a construction permit (20.2.72 NMAC) before submittal of this application? <input checked="" type="checkbox"/> Yes <input type="checkbox"/> No
3	Is the facility currently shut down? <input type="checkbox"/> Yes <input checked="" type="checkbox"/> No	If yes, give month and year of shut down (MM/YY):
4	Was this facility constructed before 8/31/1972 and continuously operated since 1972? <input type="checkbox"/> Yes <input checked="" type="checkbox"/> No	
5	If Yes to question 3, has this facility been modified (see 20.2.72.7.P NMAC) or the capacity increased since 8/31/1972? <input type="checkbox"/> Yes <input type="checkbox"/> No <input type="checkbox"/> N/A	
6	Does this facility have a Title V operating permit (20.2.70 NMAC)? <input type="checkbox"/> Yes <input checked="" type="checkbox"/> No	If yes, the permit No. is: P-
7	Has this facility been issued a No Permit Required (NPR)? <input type="checkbox"/> Yes <input checked="" type="checkbox"/> No	If yes, the NPR No. is:
8	Has this facility been issued a Notice of Intent (NOI)? <input type="checkbox"/> Yes <input type="checkbox"/> No	If yes, the NOI No. is:
9	Does this facility have a construction permit (20.2.72/20.2.74 NMAC)? <input checked="" type="checkbox"/> Yes <input type="checkbox"/> No	If yes, the permit No. is: 8153
10	Is this facility registered under a General permit (GCP-1, GCP-2, etc.)? <input type="checkbox"/> Yes <input checked="" type="checkbox"/> No	If yes, the register No. is:

### Section 1-C: Facility Input Capacity & Production Rate

1	What is the facility's maximum input capacity, specify units (reference here and list capacities in Section 20, if more room is required)			
a	Current	Hourly: 22.5 barrels; 8.8 MMscf	Daily: 539.0 barrels; 210.1 MMscf	Annually: 196,750 barrels; 76.7 Bscf
b	Proposed	Hourly: 33.9 barrels; 10 MMscf	Daily: 814 barrels; 240 MMscf	Annually: 297,184 barrels; 87.6 Bscf
2	What is the facility's maximum production rate, specify units (reference here and list capacities in Section 20, if more room is required)			
a	Current	Hourly: 22.5 barrels; 8.8 MMscf	Daily: 539.0 barrels; 210.1 MMscf	Annually: 196,750 barrels; 76.7 Bscf
b	Proposed	Hourly: 33.9 barrels; 10 MMscf	Daily: 814 barrels; 240 MMscf	Annually: 297,184 barrels; 87.6 Bscf

**Section 1-D: Facility Location Information**

1	Section: 22	Range: 31E	Township: 20S	County: Eddy	Elevation (ft): 3500
2	UTM Zone: <input type="checkbox"/> 12 or <input checked="" type="checkbox"/> 13			Datum: <input type="checkbox"/> NAD 27 <input type="checkbox"/> NAD 83 <input checked="" type="checkbox"/> WGS 84	
a	UTM E (in meters, to nearest 10 meters): 607470			UTM N (in meters, to nearest 10 meters): 3602719	
b	<b>AND</b> Latitude (deg., min., sec.): 32° 33' 24"			Longitude (deg., min., sec.): -103° 51' 19"	
3	Name and zip code of nearest New Mexico town: Carlsbad - 88220				
4	Detailed Driving Instructions from nearest NM town (attach a road map if necessary): Drive E on NM 62 for 24.7 mi. to L on lease road. Drive 1.8 mi. to L turn to site.				
5	The facility is 22 (distance) miles NE (direction) of Carlsbad (nearest town).				
6	Status of land at facility (check one): <input type="checkbox"/> Private <input type="checkbox"/> Indian/Pueblo <input checked="" type="checkbox"/> Federal BLM <input type="checkbox"/> Federal Forest Service <input type="checkbox"/> Other (specify)				
7	List all municipalities, Indian tribes, and counties within a ten (10) mile radius (20.2.72.203.B.2 NMAC) of the property on which the facility is proposed to be constructed or operated: Eddy County, Lea County				
8	<b>20.2.72 NMAC applications only:</b> Will the property on which the facility is proposed to be constructed or operated be closer than 50 km (31 miles) to other states, Bernalillo County, or a Class I area (see <a href="http://www.env.nm.gov/aqb/modeling/classIareas.html">www.env.nm.gov/aqb/modeling/classIareas.html</a> )? <input type="checkbox"/> Yes <input checked="" type="checkbox"/> No (20.2.72.206.A.7 NMAC) If yes, list all with corresponding distances in kilometers:				
9	Name nearest Class I area: Carlsbad Caverns				
10	Shortest distance (in km) from facility boundary to the boundary of the nearest Class I area (to the nearest 10 meters): 63.81				
11	Distance (meters) from the perimeter of the Area of Operations (AO is defined as the plant site inclusive of all disturbed lands, including mining overburden removal areas) to nearest residence, school or occupied structure: < 2 miles				
12	Method(s) used to delineate the Restricted Area: None  "Restricted Area" is an area to which public entry is effectively precluded. Effective barriers include continuous fencing, continuous walls, or other continuous barriers approved by the Department, such as rugged physical terrain with steep grade that would require special equipment to traverse. If a large property is completely enclosed by fencing, a restricted area within the property may be identified with signage only. Public roads cannot be part of a Restricted Area.				
13	Does the owner/operator intend to operate this source as a portable stationary source as defined in 20.2.72.7.X NMAC? <input type="checkbox"/> Yes <input checked="" type="checkbox"/> No A portable stationary source is not a mobile source, such as an automobile, but a source that can be installed permanently at one location or that can be re-installed at various locations, such as a hot mix asphalt plant that is moved to different job sites.				
14	Will this facility operate in conjunction with other air regulated parties on the same property? <input checked="" type="checkbox"/> No <input type="checkbox"/> Yes If yes, what is the name and permit number (if known) of the other facility?				

**Section 1-E: Proposed Operating Schedule** (The 1-E.1 & 1-E.2 operating schedules may become conditions in the permit.)

1	Facility <b>maximum</b> operating ( $\frac{\text{hours}}{\text{day}}$ ): 24	( $\frac{\text{days}}{\text{week}}$ ): 7	( $\frac{\text{weeks}}{\text{year}}$ ): 52	( $\frac{\text{hours}}{\text{year}}$ ): 8760
2	Facility's maximum daily operating schedule (if less than 24 $\frac{\text{hours}}{\text{day}}$ )? <b>Start:</b>		<input type="checkbox"/> AM <input type="checkbox"/> PM	<b>End:</b> <input type="checkbox"/> AM <input type="checkbox"/> PM
3	Month and year of anticipated start of construction: Already started			
4	Month and year of anticipated construction completion: Train 1 completed July 7, 2020			
5	Month and year of anticipated startup of new or modified facility: Train 1 completed July 7, 2020			
6	Will this facility operate at this site for more than one year? <input checked="" type="checkbox"/> Yes <input type="checkbox"/> No			

**Section 1-F: Other Facility Information**

1	Are there any current Notice of Violations (NOV), compliance orders, or any other compliance or enforcement issues related to this facility? <input type="checkbox"/> Yes <input checked="" type="checkbox"/> No If yes, specify:	
a	If yes, NOV date or description of issue:	NOV Tracking No:



b	Is this application in response to any issue listed in 1-F, 1 or 1a above? <input type="checkbox"/> Yes <input type="checkbox"/> No If Yes, provide the 1c & 1d info below:		
c	Document Title:	Date:	Requirement # (or page # and paragraph #):
d	Provide the required text to be inserted in this permit:		
2	Is air quality dispersion modeling or modeling waiver being submitted with this application? <input checked="" type="checkbox"/> Yes <input type="checkbox"/> No		
3	Does this facility require an "Air Toxics" permit under 20.2.72.400 NMAC & 20.2.72.502, Tables A and/or B? <input type="checkbox"/> Yes <input checked="" type="checkbox"/> No		
4	Will this facility be a source of federal Hazardous Air Pollutants (HAP)? <input checked="" type="checkbox"/> Yes <input type="checkbox"/> No		
a	If Yes, what type of source? <input checked="" type="checkbox"/> Major ( <input checked="" type="checkbox"/> ≥10 tpy of any single HAP OR <input checked="" type="checkbox"/> ≥25 tpy of any combination of HAPS) OR <input type="checkbox"/> Minor ( <input type="checkbox"/> <10 tpy of any single HAP AND <input type="checkbox"/> <25 tpy of any combination of HAPS)		
5	Is any unit exempt under 20.2.72.202.B.3 NMAC? <input type="checkbox"/> Yes <input checked="" type="checkbox"/> No		
a	If yes, include the name of company providing commercial electric power to the facility: _____ Commercial power is purchased from a commercial utility company, which specifically does not include power generated on site for the sole purpose of the user.		

**Section 1-G: Streamline Application** (This section applies to 20.2.72.300 NMAC Streamline applications only)

1	<input type="checkbox"/> I have filled out Section 18, "Addendum for Streamline Applications." <input checked="" type="checkbox"/> N/A (This is not a Streamline application.)
---	--

**Section 1-H: Current Title V Information - Required for all applications from TV Sources**

(Title V-source required information for all applications submitted pursuant to 20.2.72 NMAC (Minor Construction Permits), or 20.2.74/20.2.79 NMAC (Major PSD/NNSR applications), and/or 20.2.70 NMAC (Title V))

1	Responsible Official (R.O.) (20.2.70.300.D.2 NMAC):	Phone:
a	R.O. Title:	R.O. e-mail:
b	R. O. Address:	
2	Alternate Responsible Official (20.2.70.300.D.2 NMAC):	Phone:
a	A. R.O. Title:	A. R.O. e-mail:
b	A. R. O. Address:	
3	Company's Corporate or Partnership Relationship to any other Air Quality Permittee (List the names of any companies that have operating (20.2.70 NMAC) permits and with whom the applicant for this permit has a corporate or partnership relationship):	
4	Name of Parent Company ("Parent Company" means the primary name of the organization that owns the company to be permitted wholly or in part.):	
a	Address of Parent Company:	
5	Names of Subsidiary Companies ("Subsidiary Companies" means organizations, branches, divisions or subsidiaries, which are owned, wholly or in part, by the company to be permitted.):	
6	Telephone numbers & names of the owners' agents and site contacts familiar with plant operations:	
7	Affected Programs to include Other States, local air pollution control programs (i.e. Bernalillo) and Indian tribes: Will the property on which the facility is proposed to be constructed or operated be closer than 80 km (50 miles) from other states, local pollution control programs, and Indian tribes and pueblos (20.2.70.402.A.2 and 20.2.70.7.B)? If yes, state which ones and provide the distances in kilometers:	

## Section 1-I – Submittal Requirements

Each 20.2.73 NMAC (NOI), a 20.2.70 NMAC (Title V), a 20.2.72 NMAC (NSR minor source), or 20.2.74 NMAC (PSD) application package shall consist of the following:

### Hard Copy Submittal Requirements:

- 1) One hard copy **original signed and notarized application package printed double sided 'head-to-toe' 2-hole punched** as we bind the document on top, not on the side; except Section 2 (landscape tables), which should be **head-to-head**. Please use **numbered tab separators** in the hard copy submittal(s) as this facilitates the review process. For NOI submittals only, hard copies of UA1, Tables 2A, 2D & 2F, Section 3 and the signed Certification Page are required. **Please include a copy of the check on a separate page.**
- 2) If the application is for a minor NSR, PSD, NNSR, or Title V application, include one working hard **copy** for Department use. This **copy** should be printed in book form, 3-hole punched, and **must be double sided**. Note that this is in addition to the head-to-toe 2-hole punched copy required in 1) above. Minor NSR Technical Permit revisions (20.2.72.219.B NMAC) only need to fill out Sections 1-A, 1-B, 3, and should fill out those portions of other Section(s) relevant to the technical permit revision. TV Minor Modifications need only fill out Sections 1-A, 1-B, 1-H, 3, and those portions of other Section(s) relevant to the minor modification. NMED may require additional portions of the application to be submitted, as needed.
- 3) The entire NOI or Permit application package, including the full modeling study, should be submitted electronically. Electronic files for applications for NOIs, any type of General Construction Permit (GCP), or technical revisions to NSRs must be submitted with compact disk (CD) or digital versatile disc (DVD). For these permit application submittals, **two CD** copies are required (in sleeves, not crystal cases, please), with additional CD copies as specified below. NOI applications require only a **single CD** submittal. Electronic files for other New Source Review (construction) permits/permit modifications or Title V permits/permit modifications can be submitted on CD/DVD or sent through AQB's secure file transfer service.

### Electronic files sent by (check one):

CD/DVD attached to paper application

secure electronic transfer. Air Permit Contact Name Benjamin Schneider

Email benjamin\_schneider@xtoenergy.com

Phone number (832) 624-2768

a. If the file transfer service is chosen by the applicant, after receipt of the application, the Bureau will email the applicant with instructions for submitting the electronic files through a secure file transfer service. Submission of the electronic files through the file transfer service needs to be completed within 3 business days after the invitation is received, so the applicant should ensure that the files are ready when sending the hard copy of the application. The applicant will not need a password to complete the transfer. **Do not use the file transfer service for NOIs, any type of GCP, or technical revisions to NSR permits.**

- 4) Optionally, the applicant may submit the files with the application on compact disk (CD) or digital versatile disc (DVD) following the instructions above and the instructions in 5 for applications subject to PSD review.
- 5) If **air dispersion modeling** is required by the application type, include the **NMED Modeling Waiver** and/or electronic air dispersion modeling report, input, and output files. The dispersion modeling **summary report only** should be submitted as hard copy(ies) unless otherwise indicated by the Bureau.
- 6) If the applicant submits the electronic files on CD and the application is subject to PSD review under 20.2.74 NMAC (PSD) or NNSR under 20.2.79 NMC include,
  - a. one additional CD copy for US EPA,
  - b. one additional CD copy for each federal land manager affected (NPS, USFS, FWS, USDI) and,
  - c. one additional CD copy for each affected regulatory agency other than the Air Quality Bureau.

If the application is submitted electronically through the secure file transfer service, these extra CDs do not need to be submitted.

### Electronic Submittal Requirements [in addition to the required hard copy(ies)]:

- 1) All required electronic documents shall be submitted as 2 separate CDs or submitted through the AQB secure file transfer service. Submit a single PDF document of the entire application as submitted and the individual documents comprising the application.
- 2) The documents should also be submitted in Microsoft Office compatible file format (Word, Excel, etc.) allowing us to access the text and formulas in the documents (copy & paste). Any documents that cannot be submitted in a Microsoft Office compatible format shall be saved as a PDF file from within the electronic document that created the file. If you are unable to provide

Microsoft office compatible electronic files or internally generated PDF files of files (items that were not created electronically: i.e. brochures, maps, graphics, etc.), submit these items in hard copy format. We must be able to review the formulas and inputs that calculated the emissions.

- 3) It is preferred that this application form be submitted as 4 electronic files (3 MS Word docs: Universal Application section 1 [UA1], Universal Application section 3-19 [UA3], and Universal Application 4, the modeling report [UA4]) and 1 Excel file of the tables (Universal Application section 2 [UA2]). Please include as many of the 3-19 Sections as practical in a single MS Word electronic document. Create separate electronic file(s) if a single file becomes too large or if portions must be saved in a file format other than MS Word.
- 4) The **electronic file names** shall be a maximum of 25 characters long (including spaces, if any). The format of the electronic Universal Application shall be in the format: "A-3423-FacilityName". The "A" distinguishes the file as an application submittal, as opposed to other documents the Department itself puts into the database. Thus, all electronic application submittals should begin with "A-". Modifications to existing facilities should use the **core permit number** (i.e. '3423') the Department assigned to the facility as the next 4 digits. Use 'XXXX' for new facility applications. The format of any separate electronic submittals (additional submittals such as non-Word attachments, re-submittals, application updates) and Section document shall be in the format: "A-3423-9-description", where "9" stands for the **section #** (in this case Section 9-Public Notice). Please refrain, as much as possible, from submitting any scanned documents as this file format is extremely large, which uses up too much storage capacity in our database. Please take the time to fill out the **header information** throughout all submittals as this will identify any loose pages, including the Application Date (date submitted) & Revision number (0 for original, 1, 2, etc.; which will help keep track of subsequent partial update(s) to the original submittal. Do not use special symbols (#, @, etc.) in file names. The footer information should not be modified by the applicant.

## Table of Contents

<b>Section 1:</b>	<b>General Facility Information</b>
<b>Section 2:</b>	<b>Tables</b>
<b>Section 3:</b>	<b>Application Summary</b>
<b>Section 4:</b>	<b>Process Flow Sheet</b>
<b>Section 5:</b>	<b>Plot Plan Drawn to Scale</b>
<b>Section 6:</b>	<b>All Calculations</b>
<b>Section 7:</b>	<b>Information Used to Determine Emissions</b>
<b>Section 8:</b>	<b>Map(s)</b>
<b>Section 9:</b>	<b>Proof of Public Notice</b>
<b>Section 10:</b>	<b>Written Description of the Routine Operations of the Facility</b>
<b>Section 11:</b>	<b>Source Determination</b>
<b>Section 12:</b>	<b>PSD Applicability Determination for All Sources &amp; Special Requirements for a PSD Application</b>
<b>Section 13:</b>	<b>Discussion Demonstrating Compliance with Each Applicable State &amp; Federal Regulation</b>
<b>Section 14:</b>	<b>Operational Plan to Mitigate Emissions</b>
<b>Section 15:</b>	<b>Alternative Operating Scenarios</b>
<b>Section 16:</b>	<b>Air Dispersion Modeling</b>
<b>Section 17:</b>	<b>Compliance Test History</b>
<b>Section 18:</b>	<b>Addendum for Streamline Applications (streamline applications only)</b>
<b>Section 19:</b>	<b>Requirements for the Title V (20.2.70 NMAC) Program (Title V applications only)</b>
<b>Section 20:</b>	<b>Other Relevant Information</b>
<b>Section 21:</b>	<b>Addendum for Landfill Applications</b>
<b>Section 22:</b>	<b>Certification Page</b>

**Tab 2**  
**UA2 Form - Application Tables**

### Cross reference table of all units in both permits

Unit numbers must correspond to unit numbers in the previous permit unless a complete cross reference table of all units in both permits

Previous Unit Number	Previous Source Description	New Unit Number	New Source Description	Notes
ENG1	Natural Gas Engine	ENG1	Natural Gas Compressor Engine	Updated Caterpillar Gas Engine Rating Pro (GERP) analysis with new fuel gas analysis, which resulted in changes to VOC/CO/formaldehyde emission factors. Updated catalyst control efficiencies with updated fuel gas specifications.
ENG2	Natural Gas Engine	ENG2	Natural Gas Compressor Engine	
ENG3	Natural Gas Engine	ENG3	Natural Gas Compressor Engine	
ENG4	Natural Gas Engine	ENG4	Natural Gas Compressor Engine	
ENG5	Natural Gas Engine	ENG5	Natural Gas Compressor Engine	
ENG6	Natural Gas Engine	ENG6	Natural Gas Compressor Engine	
ENG7	Natural Gas Engine	ENG7	Natural Gas Compressor Engine	
ENG8	Natural Gas Engine	ENG8	Natural Gas Compressor Engine	
ENG9	Natural Gas Engine	ENG9	Natural Gas Compressor Engine	
ENG10	Natural Gas Engine			
ENG11	Natural Gas Engine	ENG11	Natural Gas Compressor Engine	Same as ENG1-9.
ENG12	Natural Gas Engine	ENG12	Natural Gas Compressor Engine	
ENG13	Natural Gas Engine			Removed
HTR1	Hot Oil Heater 1	HTR1	Fuel Line Heater	
HTR2	Hot Oil Heater 2			Removed
HTR3	Hot Oil Heater 3			Removed
RB1	Glycol Regenerator Reboiler	RB1	Glycol Regenerator Reboiler	
RB2	Glycol Regenerator Reboiler	RB2	Glycol Regenerator Reboiler	
RB3	Glycol Regenerator Reboiler	RB3	Glycol Regenerator Reboiler	
FL1	Flare 1	FL1	Flare 1	Changed combustion sources
FL2	Flare 2	FL2	Flare 2	Changed combustion sources
FL3	Flare 3			Removed
VC1	Combustor	VC1	Combustor	Changed combustion sources
GB1a	Gun Barrel Separator (Primary)	SKT1	Skim Tank	Renamed
GB1b	Gun Barrel Separator (Backup)	SKT2	Skim Tank (Backup)	Renamed
OT1	Condensate Tank	OT1	Condensate Tank	
OT2	Condensate Tank	OT2	Condensate Tank	
OT3	Condensate Tank	OT3	Condensate Tank	
OT4	Condensate Tank	OT4	Condensate Tank	
WT1	Produced Water Tank	WT1	Produced Water Tank	
WT2	Produced Water Tank	WT2	Produced Water Tank	
		VRU1	Low Pressure Separator VRU #1	Added control efficiency
		VRU2	Low Pressure Separator VRU Backup	Added control efficiency
DEHY1	TEG Dehydrator with Condenser	DEHY1	TEG Dehydrator with Condenser	
DEHY2	TEG Dehydrator with Condenser	DEHY2	TEG Dehydrator with Condenser	
DEHY3	TEG Dehydrator with Condenser	DEHY3	TEG Dehydrator with Condenser	
LPS	Low Pressure Separator	LPS	Low Pressure Separator	
LOAD	Truck Loading	LOAD	Condensate Truck Loading	
FUG	Fugitives	FUG	Fugitive Emissions	
SSM	SSM Activities	SSM	SSM Activities	
ROAD	HAUL ROAD EMISSIONS	ROAD	HAUL ROAD EMISSIONS	

**Table 2-A: Regulated Emission Sources**

Unit and stack numbering must correspond throughout the application package. Equipment exemptions under 2.72.202 NMAC do not apply to 20.2.73 NMAC. Identify process equipment that is used to reroute emissions back into the process or sales pipeline in Table 2-A, such as a VRU, VRT, ULPS, Flashing Vessel, or Blowcase.

Unit Number <sup>1</sup>	Source Description	Make	Model #	Serial #	Manufact-urer's Rated Capacity <sup>2</sup> (Specify Units)	Requested Permitted Capacity <sup>3</sup> (Specify Units)	Date of Manufacture <sup>2</sup>	Controlled by Unit #	Source Classification Code (SCC)	For Each Piece of Equipment, Check One	RICE Ignition Type (CI, SL, 4SLB, 4SRB, 2SLB) <sup>4</sup>	Replacing Unit No.
							Date of Construction/ Reconstruction <sup>2</sup>	Emissions vented to Stack #				
ENG1	Natural Gas Compressor Engine	Caterpillar	G3616	ZZY00890	5000	5000	1/1/2019	ENG1	20200254	<input type="checkbox"/> Existing (unchanged) <input type="checkbox"/> To be Removed <input type="checkbox"/> New/Additional <input type="checkbox"/> Replacement Unit <input checked="" type="checkbox"/> To Be Modified <input type="checkbox"/> To be Replaced	4SLB	N/A
							1/1/2019	CAT1				
ENG2	Natural Gas Compressor Engine	Caterpillar	G3616	ZZY00986	5000	5000	2/1/2019	ENG2	20200254	<input type="checkbox"/> Existing (unchanged) <input type="checkbox"/> To be Removed <input type="checkbox"/> New/Additional <input type="checkbox"/> Replacement Unit <input checked="" type="checkbox"/> To Be Modified <input type="checkbox"/> To be Replaced	4SLB	N/A
							2/1/2019	CAT2				
ENG3	Natural Gas Compressor Engine	Caterpillar	G3616	ZZY00829	5000	5000	8/1/2018	ENG3	20200254	<input type="checkbox"/> Existing (unchanged) <input type="checkbox"/> To be Removed <input type="checkbox"/> New/Additional <input type="checkbox"/> Replacement Unit <input checked="" type="checkbox"/> To Be Modified <input type="checkbox"/> To be Replaced	4SLB	N/A
							8/1/2018	CAT3				
ENG4	Natural Gas Compressor Engine	Caterpillar	G3616	TBD	5000	5000	TBD	ENG4	20200254	<input type="checkbox"/> Existing (unchanged) <input type="checkbox"/> To be Removed <input type="checkbox"/> New/Additional <input type="checkbox"/> Replacement Unit <input checked="" type="checkbox"/> To Be Modified <input type="checkbox"/> To be Replaced	4SLB	N/A
							TBD	CAT4				
ENG5	Natural Gas Compressor Engine	Caterpillar	G3616	TBD	5000	5000	TBD	ENG5	20200254	<input type="checkbox"/> Existing (unchanged) <input type="checkbox"/> To be Removed <input type="checkbox"/> New/Additional <input type="checkbox"/> Replacement Unit <input checked="" type="checkbox"/> To Be Modified <input type="checkbox"/> To be Replaced	4SLB	N/A
							TBD	CAT5				
ENG6	Natural Gas Compressor Engine	Caterpillar	G3616	TBD	5000	5000	TBD	ENG6	20200254	<input type="checkbox"/> Existing (unchanged) <input type="checkbox"/> To be Removed <input type="checkbox"/> New/Additional <input type="checkbox"/> Replacement Unit <input checked="" type="checkbox"/> To Be Modified <input type="checkbox"/> To be Replaced	4SLB	N/A
							TBD	CAT6				
ENG7	Natural Gas Compressor Engine	Caterpillar	G3616	TBD	5000	5000	TBD	ENG7	20200254	<input type="checkbox"/> Existing (unchanged) <input type="checkbox"/> To be Removed <input type="checkbox"/> New/Additional <input type="checkbox"/> Replacement Unit <input checked="" type="checkbox"/> To Be Modified <input type="checkbox"/> To be Replaced	4SLB	N/A
							TBD	CAT7				
ENG8	Natural Gas Compressor Engine	Caterpillar	G3616	TBD	5000	5000	TBD	ENG8	20200254	<input type="checkbox"/> Existing (unchanged) <input type="checkbox"/> To be Removed <input type="checkbox"/> New/Additional <input type="checkbox"/> Replacement Unit <input checked="" type="checkbox"/> To Be Modified <input type="checkbox"/> To be Replaced	4SLB	N/A
							TBD	CAT8				
ENG9	Natural Gas Compressor Engine	Caterpillar	G3616	TBD	5000	5000	TBD	ENG9	20200254	<input type="checkbox"/> Existing (unchanged) <input type="checkbox"/> To be Removed <input type="checkbox"/> New/Additional <input type="checkbox"/> Replacement Unit <input checked="" type="checkbox"/> To Be Modified <input type="checkbox"/> To be Replaced	4SLB	N/A
							TBD	CAT9				
ENG11	Natural Gas Compressor Engine	Caterpillar	3516J TA	N6W01221	1380	1380	2/1/2019	ENG11	20200254	<input type="checkbox"/> Existing (unchanged) <input type="checkbox"/> To be Removed <input type="checkbox"/> New/Additional <input type="checkbox"/> Replacement Unit <input checked="" type="checkbox"/> To Be Modified <input type="checkbox"/> To be Replaced	4SLB	N/A
							2/1/2019	CAT11				
ENG12	Natural Gas Compressor Engine	Caterpillar	3516J TA	N6W01223	1380	1380	2/1/2019	ENG12	20200254	<input type="checkbox"/> Existing (unchanged) <input type="checkbox"/> To be Removed <input type="checkbox"/> New/Additional <input type="checkbox"/> Replacement Unit <input checked="" type="checkbox"/> To Be Modified <input type="checkbox"/> To be Replaced	4SLB	N/A
							2/1/2019	CAT12				
ENG10	Natural Gas Compressor Engine	Caterpillar	G3606TA	TBD	1775	1775	TBD	ENG10	20200254	<input type="checkbox"/> Existing (unchanged) <input checked="" type="checkbox"/> To be Removed <input type="checkbox"/> New/Additional <input type="checkbox"/> Replacement Unit <input type="checkbox"/> To Be Modified <input type="checkbox"/> To be Replaced	4SLB	N/A
							TBD	CAT10				
ENG13	Natural Gas Compressor Engine	Caterpillar	G3306TA	TBD	203	203	TBD	ENG13	20200254	<input type="checkbox"/> Existing (unchanged) <input checked="" type="checkbox"/> To be Removed <input type="checkbox"/> New/Additional <input type="checkbox"/> Replacement Unit <input type="checkbox"/> To Be Modified <input type="checkbox"/> To be Replaced	4SRB	N/A
							TBD	CAT13				
HTR1	Fuel Line Heater	Wenco Energy Corp	SB20-12H	0819-950	0.75 MMBtu/hr	0.75 MMBtu/hr	2019	TBD	31000228	<input checked="" type="checkbox"/> Existing (unchanged) <input type="checkbox"/> To be Removed <input type="checkbox"/> New/Additional <input type="checkbox"/> Replacement Unit <input type="checkbox"/> To Be Modified <input type="checkbox"/> To be Replaced	N/A	N/A
							2019	HTR1				
RB1	Glycol Regenerator Reboiler	Flameco	FA-40719-23	1861-095	2.0 MMBtu/hr	2.0 MMBtu/hr	2019	N/A	31000404	<input type="checkbox"/> Existing (unchanged) <input type="checkbox"/> To be Removed <input type="checkbox"/> New/Additional <input type="checkbox"/> Replacement Unit <input checked="" type="checkbox"/> To Be Modified <input type="checkbox"/> To be Replaced	N/A	N/A
							2019	RB1				
RB2	Glycol Regenerator Reboiler	TBD	TBD	TBD	2.0 MMBtu/hr	2.0 MMBtu/hr	TBD	N/A	31000404	<input type="checkbox"/> Existing (unchanged) <input type="checkbox"/> To be Removed <input type="checkbox"/> New/Additional <input type="checkbox"/> Replacement Unit <input checked="" type="checkbox"/> To Be Modified <input type="checkbox"/> To be Replaced	N/A	N/A
							TBD	RB2				
RB3	Glycol Regenerator Reboiler	TBD	TBD	TBD	2.0 MMBtu/hr	2.0 MMBtu/hr	TBD	N/A	31000404	<input type="checkbox"/> Existing (unchanged) <input type="checkbox"/> To be Removed <input type="checkbox"/> New/Additional <input type="checkbox"/> Replacement Unit <input checked="" type="checkbox"/> To Be Modified <input type="checkbox"/> To be Replaced	N/A	N/A
							TBD	RB3				
HTR2	Fuel Line Heater	N/A	N/A	N/A	0.75 MMBtu/hr	0.75 MMBtu/hr	TBD	N/A	31000228	<input type="checkbox"/> Existing (unchanged) <input checked="" type="checkbox"/> To be Removed <input type="checkbox"/> New/Additional <input type="checkbox"/> Replacement Unit <input type="checkbox"/> To Be Modified <input type="checkbox"/> To be Replaced	N/A	N/A
							N/A	HTR2				
HTR3	Fuel Line Heater	N/A	N/A	N/A	1.5 MMBtu/hr	1.5 MMBtu/hr	TBD	N/A	31000228	<input type="checkbox"/> Existing (unchanged) <input checked="" type="checkbox"/> To be Removed <input type="checkbox"/> New/Additional <input type="checkbox"/> Replacement Unit <input type="checkbox"/> To Be Modified <input type="checkbox"/> To be Replaced	N/A	N/A
							N/A	HTR3				

Unit Number <sup>1</sup>	Source Description	Make	Model #	Serial #	Manufacturer's Rated Capacity <sup>2</sup> (Specify Units)	Requested Permitted Capacity <sup>2</sup> (Specify Units)	Date of Manufacture <sup>2</sup>	Controlled by Unit #	Source Classification Code (SCC)	For Each Piece of Equipment, Check One	RICE Ignition Type (CI, SI, 4SLB, 4SRB, 2SLB) <sup>4</sup>	Replacing Unit No.
							Date of Construction/ Reconstruction <sup>2</sup>	Emissions vented to Stack #				
FL1	Flare 1	Tornado	GUYED DUAL AIR ASSIST	14783/17152	70 MMscf/d	70 MMscf/d	2019	N/A	31000205	<input type="checkbox"/> Existing (unchanged) <input type="checkbox"/> To be Removed <input type="checkbox"/> New/Additional <input type="checkbox"/> Replacement Unit <input checked="" type="checkbox"/> To be Modified <input type="checkbox"/> To be Replaced	N/A	N/A
FL2	Flare 2	Tornado	TBD	TBD	70 MMscf/d	70 MMscf/d	TBD	N/A	31000205	<input type="checkbox"/> Existing (unchanged) <input type="checkbox"/> To be Removed <input type="checkbox"/> New/Additional <input type="checkbox"/> Replacement Unit <input checked="" type="checkbox"/> To be Modified <input type="checkbox"/> To be Replaced	N/A	N/A
VC1	Still Vent Emissions	CIMARRON ENERGY	N/A	5004793	N/A	N/A	2019	N/A	31000205	<input type="checkbox"/> Existing (unchanged) <input type="checkbox"/> To be Removed <input type="checkbox"/> New/Additional <input type="checkbox"/> Replacement Unit <input checked="" type="checkbox"/> To be Modified <input type="checkbox"/> To be Replaced	N/A	N/A
FL3	Flare 3	Tornado	TBD	TBD	70 MMscf/d	70 MMscf/d	TBD	N/A	31000205	<input type="checkbox"/> Existing (unchanged) <input checked="" type="checkbox"/> To be Removed <input type="checkbox"/> New/Additional <input type="checkbox"/> Replacement Unit <input type="checkbox"/> To be Modified <input type="checkbox"/> To be Replaced	N/A	N/A
SKT1	Skim Tank	STELLMATION	TBD	P-000-469-918-000001	1000 bbl	1000 bbl	2019	FL1-FL2	40400311	<input type="checkbox"/> Existing (unchanged) <input type="checkbox"/> To be Removed <input type="checkbox"/> New/Additional <input type="checkbox"/> Replacement Unit <input checked="" type="checkbox"/> To be Modified <input type="checkbox"/> To be Replaced	N/A	N/A
SKT2	Skim Tank (Backup)	TBD	TBD	TBD	1000 bbl	1000 bbl	TBD	FL1-FL2	40400311	<input type="checkbox"/> Existing (unchanged) <input type="checkbox"/> To be Removed <input type="checkbox"/> New/Additional <input type="checkbox"/> Replacement Unit <input checked="" type="checkbox"/> To be Modified <input type="checkbox"/> To be Replaced	N/A	N/A
OT1	Condensate Tank	STELLMATION	TBD	P-000-462-144-000010	500 bbl	500 bbl	2019	FL1-FL2	40400311	<input type="checkbox"/> Existing (unchanged) <input type="checkbox"/> To be Removed <input type="checkbox"/> New/Additional <input type="checkbox"/> Replacement Unit <input checked="" type="checkbox"/> To be Modified <input type="checkbox"/> To be Replaced	N/A	N/A
OT2	Condensate Tank	STELLMATION	TBD	P-000-462-144-000001	500 bbl	500 bbl	2019	FL1-FL2	40400311	<input type="checkbox"/> Existing (unchanged) <input type="checkbox"/> To be Removed <input type="checkbox"/> New/Additional <input type="checkbox"/> Replacement Unit <input checked="" type="checkbox"/> To be Modified <input type="checkbox"/> To be Replaced	N/A	N/A
OT3	Condensate Tank	STELLMATION	TBD	P-000-462-114-000003	500 bbl	500 bbl	2019	FL1-FL2	40400311	<input type="checkbox"/> Existing (unchanged) <input type="checkbox"/> To be Removed <input type="checkbox"/> New/Additional <input type="checkbox"/> Replacement Unit <input checked="" type="checkbox"/> To be Modified <input type="checkbox"/> To be Replaced	N/A	N/A
OT4	Condensate Tank	STELLMATION	TBD	P-000-462-144-000007	500 bbl	500 bbl	2019	FL1-FL2	40400311	<input type="checkbox"/> Existing (unchanged) <input type="checkbox"/> To be Removed <input type="checkbox"/> New/Additional <input type="checkbox"/> Replacement Unit <input checked="" type="checkbox"/> To be Modified <input type="checkbox"/> To be Replaced	N/A	N/A
WT1	Produced Water Tank	STELLMATION	TBD	P-000-462-114-000005	500 bbl	500 bbl	2019	FL1-FL2	40400315	<input type="checkbox"/> Existing (unchanged) <input type="checkbox"/> To be Removed <input type="checkbox"/> New/Additional <input type="checkbox"/> Replacement Unit <input checked="" type="checkbox"/> To be Modified <input type="checkbox"/> To be Replaced	N/A	N/A
WT2	Produced Water Tank	STELLMATION	TBD	P-000-462-144-000008	500 bbl	500 bbl	2019	FL1-FL2	40400315	<input type="checkbox"/> Existing (unchanged) <input type="checkbox"/> To be Removed <input type="checkbox"/> New/Additional <input type="checkbox"/> Replacement Unit <input checked="" type="checkbox"/> To be Modified <input type="checkbox"/> To be Replaced	N/A	N/A
VRU1	Low Pressure Separator VRU #1	PLATINUM VAPOR CONTROL	PVR-1829	N/A	125 HP	125 HP	2019	FL1-FL2	N/A	<input type="checkbox"/> Existing (unchanged) <input type="checkbox"/> To be Removed <input type="checkbox"/> New/Additional <input type="checkbox"/> Replacement Unit <input checked="" type="checkbox"/> To be Modified <input type="checkbox"/> To be Replaced	N/A	N/A
VRU2	Low Pressure Separator VRU Backup	PLATINUM VAPOR CONTROL	PVR-1828	N/A	125 HP	125 HP	2019	FL1-FL2	N/A	<input type="checkbox"/> Existing (unchanged) <input type="checkbox"/> To be Removed <input type="checkbox"/> New/Additional <input type="checkbox"/> Replacement Unit <input checked="" type="checkbox"/> To be Modified <input type="checkbox"/> To be Replaced	N/A	N/A
DEHY1	TEG Dehydrator with Condenser	N/A	N/A	N/A	80 MMscfd	80 MMscfd	2019	COND1	31000227	<input type="checkbox"/> Existing (unchanged) <input type="checkbox"/> To be Removed <input type="checkbox"/> New/Additional <input type="checkbox"/> Replacement Unit <input checked="" type="checkbox"/> To be Modified <input type="checkbox"/> To be Replaced	N/A	N/A
DEHY2	TEG Dehydrator with Condenser	N/A	N/A	N/A	80 MMscfd	80 MMscfd	TBD	COND2	31000227	<input type="checkbox"/> Existing (unchanged) <input type="checkbox"/> To be Removed <input type="checkbox"/> New/Additional <input type="checkbox"/> Replacement Unit <input checked="" type="checkbox"/> To be Modified <input type="checkbox"/> To be Replaced	N/A	N/A
DEHY3	TEG Dehydrator with Condenser	N/A	N/A	N/A	80 MMscfd	80 MMscfd	TBD	COND3	31000227	<input type="checkbox"/> Existing (unchanged) <input type="checkbox"/> To be Removed <input type="checkbox"/> New/Additional <input type="checkbox"/> Replacement Unit <input checked="" type="checkbox"/> To be Modified <input type="checkbox"/> To be Replaced	N/A	N/A
LPS	Low Pressure Separator	N/A	N/A	N/A	N/A	N/A	2019	FL1-FL2	N/A	<input type="checkbox"/> Existing (unchanged) <input type="checkbox"/> To be Removed <input type="checkbox"/> New/Additional <input type="checkbox"/> Replacement Unit <input checked="" type="checkbox"/> To be Modified <input type="checkbox"/> To be Replaced	N/A	N/A
LOAD	Condensate Truck Loading	N/A	N/A	N/A	223 bbl/d	223 bbl/d	N/A	N/A	40400250	<input type="checkbox"/> Existing (unchanged) <input type="checkbox"/> To be Removed <input type="checkbox"/> New/Additional <input type="checkbox"/> Replacement Unit <input checked="" type="checkbox"/> To be Modified <input type="checkbox"/> To be Replaced	N/A	N/A
FUG	Fugitive Emissions	N/A	N/A	N/A	N/A	N/A	N/A	N/A	31088811	<input type="checkbox"/> Existing (unchanged) <input type="checkbox"/> To be Removed <input type="checkbox"/> New/Additional <input type="checkbox"/> Replacement Unit <input checked="" type="checkbox"/> To be Modified <input type="checkbox"/> To be Replaced	N/A	N/A
SSM	SSM Activities	N/A	N/A	N/A	N/A	N/A	N/A	N/A	31088811	<input checked="" type="checkbox"/> Existing (unchanged) <input type="checkbox"/> To be Removed <input type="checkbox"/> New/Additional <input type="checkbox"/> Replacement Unit <input type="checkbox"/> To be Modified <input type="checkbox"/> To be Replaced	N/A	N/A
Malfunction	Malfunction Emissions	N/A	N/A	N/A	N/A	N/A	N/A	N/A	31088811	<input type="checkbox"/> Existing (unchanged) <input type="checkbox"/> To be Removed <input checked="" type="checkbox"/> New/Additional <input type="checkbox"/> Replacement Unit <input type="checkbox"/> To be Modified <input type="checkbox"/> To be Replaced	N/A	N/A

<sup>1</sup> Unit numbers must correspond to unit numbers in the previous NOI unless a complete cross reference table of all units in both NOIs is provided.  
<sup>2</sup> Specify dates required to determine regulatory applicability.  
<sup>3</sup> To properly account for power conversion efficiencies, generator set rated capacity shall be reported as the rated capacity of the engine in horsepower, not the kilowatt capacity of the generator set.  
<sup>4</sup> "4SLB" means four stroke lean burn engine, "4SRB" means four stroke rich burn engine, "2SLB" means two stroke lean burn engine, "CI" means compression ignition, and "SI" means spark ignition

**Table 2-B: Insignificant Activities<sup>1</sup> (20.2.70 NMAC) OR Exempted Equipment (20.2.72 NMAC)**

All 20.2.70 NMAC (Title V) applications must list all Insignificant Activities in this table. All 20.2.72 NMAC applications must list Exempted Equipment in this table. If equipment listed on this table is exempt under 20.2.72.202.B.5, include emissions calculations and emissions totals for 20.2.72.202.B.5 "similar functions" units, operations, and activities in Section 6, Calculations. Equipment and activities exempted under 20.2.72.202 NMAC may not necessarily be Insignificant under 20.2.70 NMAC (and vice versa). Unit & stack numbering must be consistent throughout the application package. Per Exemptions Policy 02-012.00 (see [http://www.env.nm.gov/aqb/permit/aqb\\_pol.html](http://www.env.nm.gov/aqb/permit/aqb_pol.html)), 20.2.72.202.B NMAC Exemptions do not apply, but 20.2.72.202.A NMAC exemptions do apply to NOI facilities under 20.2.73 NMAC. List 20.2.72.301.D.4 NMAC Auxiliary Equipment for Streamline applications in Table 2-A. The List of Insignificant Activities (for TV) can be found online at <http://www.env.nm.gov/aqb/forms/InsignificantListTitleV.pdf>. TV sources may elect to enter both TV Insignificant Activities and Part 72 Exemptions on this form.

Unit Number	Source Description	Manufacturer	Model No.	Max Capacity	List Specific 20.2.72.202 NMAC Exemption (e.g. 20.2.72.202.B.5)	Date of Manufacture /Reconstruction <sup>2</sup>	For Each Piece of Equipment, Check One
			Serial No.	Capacity Units	Insignificant Activity citation (e.g. IA List Item #1.a)	Date of Installation /Construction <sup>2</sup>	
ROAD	Haul Road Emissions	N/A	N/A	N/A	20.2.72.202.B.5	N/A	<input checked="" type="checkbox"/> Existing (unchanged) <input type="checkbox"/> To be Removed <input type="checkbox"/> New/Additional <input type="checkbox"/> Replacement Unit <input type="checkbox"/> To Be Modified <input type="checkbox"/> To be Replaced
			N/A	N/A	20.2.72.202.B.5	N/A	<input type="checkbox"/> Existing (unchanged) <input type="checkbox"/> To be Removed <input type="checkbox"/> New/Additional <input type="checkbox"/> Replacement Unit <input type="checkbox"/> To Be Modified <input type="checkbox"/> To be Replaced
							<input type="checkbox"/> Existing (unchanged) <input type="checkbox"/> To be Removed <input type="checkbox"/> New/Additional <input type="checkbox"/> Replacement Unit <input type="checkbox"/> To Be Modified <input type="checkbox"/> To be Replaced
							<input type="checkbox"/> Existing (unchanged) <input type="checkbox"/> To be Removed <input type="checkbox"/> New/Additional <input type="checkbox"/> Replacement Unit <input type="checkbox"/> To Be Modified <input type="checkbox"/> To be Replaced
							<input type="checkbox"/> Existing (unchanged) <input type="checkbox"/> To be Removed <input type="checkbox"/> New/Additional <input type="checkbox"/> Replacement Unit <input type="checkbox"/> To Be Modified <input type="checkbox"/> To be Replaced
							<input type="checkbox"/> Existing (unchanged) <input type="checkbox"/> To be Removed <input type="checkbox"/> New/Additional <input type="checkbox"/> Replacement Unit <input type="checkbox"/> To Be Modified <input type="checkbox"/> To be Replaced
							<input type="checkbox"/> Existing (unchanged) <input type="checkbox"/> To be Removed <input type="checkbox"/> New/Additional <input type="checkbox"/> Replacement Unit <input type="checkbox"/> To Be Modified <input type="checkbox"/> To be Replaced
							<input type="checkbox"/> Existing (unchanged) <input type="checkbox"/> To be Removed <input type="checkbox"/> New/Additional <input type="checkbox"/> Replacement Unit <input type="checkbox"/> To Be Modified <input type="checkbox"/> To be Replaced
							<input type="checkbox"/> Existing (unchanged) <input type="checkbox"/> To be Removed <input type="checkbox"/> New/Additional <input type="checkbox"/> Replacement Unit <input type="checkbox"/> To Be Modified <input type="checkbox"/> To be Replaced
							<input type="checkbox"/> Existing (unchanged) <input type="checkbox"/> To be Removed <input type="checkbox"/> New/Additional <input type="checkbox"/> Replacement Unit <input type="checkbox"/> To Be Modified <input type="checkbox"/> To be Replaced
							<input type="checkbox"/> Existing (unchanged) <input type="checkbox"/> To be Removed <input type="checkbox"/> New/Additional <input type="checkbox"/> Replacement Unit <input type="checkbox"/> To Be Modified <input type="checkbox"/> To be Replaced
							<input type="checkbox"/> Existing (unchanged) <input type="checkbox"/> To be Removed <input type="checkbox"/> New/Additional <input type="checkbox"/> Replacement Unit <input type="checkbox"/> To Be Modified <input type="checkbox"/> To be Replaced
							<input type="checkbox"/> Existing (unchanged) <input type="checkbox"/> To be Removed <input type="checkbox"/> New/Additional <input type="checkbox"/> Replacement Unit <input type="checkbox"/> To Be Modified <input type="checkbox"/> To be Replaced

<sup>1</sup> Insignificant activities exempted due to size or production rate are defined in 20.2.70.300.D.6, 20.2.70.7.Q NMAC, and the NMED/AQB List of Insignificant Activities, dated September 15, 2008. Emissions from these insignificant activities do not need to be reported, unless specifically requested.

<sup>2</sup> Specify date(s) required to determine regulatory applicability.



**Table 2-C: Emissions Control Equipment**

Unit and stack numbering must correspond throughout the application package. The permittee shall report all control devices and list each pollutant controlled by the control device regardless if the applicant takes credit for the reduction in emissions. Flares, Enclosed Combustion Devices, Catalytic Converters and Air Fuel Ratio (AFR) Controllers shall be reported on Table 2-C. For each AFR, note whether the AFR are aftermarket or integral to the engine.

Control Equipment Unit No.	Control Equipment Description	Date Installed	Controlled Pollutant(s)	Controlling Emissions for Unit Number(s) <sup>1</sup>	Efficiency (% Control by Weight)	Method used to Estimate Efficiency
FL1	Flare 1	2019	VOC, HAP	Facility Inlet, OT1-OT4, WT1-WT2, SKTK1/SKTK2, LPS	98	Engineering Est.
FL2	Flare 2	TBD	VOC, HAP	Facility Inlet, OT1-OT4, WT1-WT2, SKTK1/SKTK2, LPS	98	Engineering Est.
VC1	Still Vent Emissions	2019	VOC, HAP	DEHY1-3 BTEX Condenser Vapors	98	Engineering Est.
FL3	Flare 3	TBD	VOC, HAP	Facility Inlet, OT1-OT4, WT1-WT2, SKTK1/SKTK2, LPS	98	Engineering Est.
VRU1	Low Pressure Separator VRU #1	2019	VOC, HAPs	LPS	98	Engineering Est.
VRU2	Low Pressure Separator VRU Backup	2019	VOC, HAPs	LPS	98	Engineering Est.
COND1-COND3	BTEX Condenser	2019	VOC, HAP	DEHY1-DEHY3	98	Engineering Est.
CAT1-CAT12	Engine Catalysts	2019	CO, VOC, HAP	ENG1-ENG12	CO-85, VOC/HAP-73	Engineering Est.

<sup>1</sup> List each control device on a separate line. For each control device, list all emission units controlled by the control device.

**Table 2-D: Maximum Emissions** (under normal operating conditions)

Maximum Emissions are the emissions at maximum capacity and prior to (in the absence of) pollution control, emission-reducing process equipment, or any other emission reduction. Calculate the hourly emissions using the worst case hourly emissions for each pollutant. For each pollutant, calculate the annual emissions as if the facility were operating at maximum plant capacity without pollution controls for 8760 hours per year, unless otherwise approved by the Department. List Hazardous Air Pollutants (HAP) & Toxic Air Pollutants (TAPs) in Table 2-I. Unit & stack numbering must be consistent throughout the application package. Fill all cells in this table with the emission numbers or a "-" symbol. A "-" symbol indicates that emissions of this pollutant are not expected. Numbers shall be expressed to at least 2 decimal points (e.g. 0.41, 1.41, or 1.41E-4).

Unit No.	NOx		CO		VOC		SOx		PM <sup>1</sup>		PM10 <sup>1</sup>		PM2.5 <sup>1</sup>		H <sub>2</sub> S		Lead	
	lb/hr	ton/yr	lb/hr	ton/yr	lb/hr	ton/yr	lb/hr	ton/yr	lb/hr	ton/yr	lb/hr	ton/yr	lb/hr	ton/yr	lb/hr	ton/yr	lb/hr	ton/yr
ENG1	4.13	18.11	33.73	147.74	9.90	43.37	0.42	1.84	0.38	1.65	0.38	1.65	0.38	1.65	-	-	-	-
ENG2	4.13	18.11	33.73	147.74	9.90	43.37	0.42	1.84	0.38	1.65	0.38	1.65	0.38	1.65	-	-	-	-
ENG3	4.13	18.11	33.73	147.74	9.90	43.37	0.42	1.84	0.38	1.65	0.38	1.65	0.38	1.65	-	-	-	-
ENG4	4.13	18.11	33.73	147.74	9.90	43.37	0.42	1.84	0.38	1.65	0.38	1.65	0.38	1.65	-	-	-	-
ENG5	4.13	18.11	33.73	147.74	9.90	43.37	0.42	1.84	0.38	1.65	0.38	1.65	0.38	1.65	-	-	-	-
ENG6	4.13	18.11	33.73	147.74	9.90	43.37	0.42	1.84	0.38	1.65	0.38	1.65	0.38	1.65	-	-	-	-
ENG7	4.13	18.11	33.73	147.74	9.90	43.37	0.42	1.84	0.38	1.65	0.38	1.65	0.38	1.65	-	-	-	-
ENG8	4.13	18.11	33.73	147.74	9.90	43.37	0.42	1.84	0.38	1.65	0.38	1.65	0.38	1.65	-	-	-	-
ENG9	4.13	18.11	33.73	147.74	9.90	43.37	0.42	1.84	0.38	1.65	0.38	1.65	0.38	1.65	-	-	-	-
ENG11	1.90	8.33	7.76	33.98	3.96	17.33	0.13	0.55	0.11	0.49	0.11	0.49	0.11	0.49	-	-	-	-
ENG12	1.90	8.33	7.76	33.98	3.96	17.33	0.13	0.55	0.11	0.49	0.11	0.49	0.11	0.49	-	-	-	-
HTR1	0.11	0.50	0.10	0.42	0.01	0.03	0.01	0.04	0.01	0.04	0.01	0.04	0.01	0.04	-	-	-	-
RB1	0.31	1.34	0.26	1.12	0.02	0.07	0.03	0.12	0.02	0.10	0.02	0.10	0.02	0.10	-	-	-	-
RB2	0.31	1.34	0.26	1.12	0.02	0.07	0.03	0.12	0.02	0.10	0.02	0.10	0.02	0.10	-	-	-	-
RB3	0.31	1.34	0.26	1.12	0.02	0.07	0.03	0.12	0.02	0.10	0.02	0.10	0.02	0.10	-	-	-	-
FL1-FL2 Pilot	0.67	2.93	1.33	5.84	0.94	4.13	0.01	0.03	0.03	0.13	0.03	0.13	0.03	0.13	-	-	-	-
FL1-FL2 Norm	Emissions are not routed to flare in uncontrolled scenario.																	
FL1-FL2 SSM	Emissions are not routed to flare in uncontrolled scenario.																	
VC1	0.41	1.80	0.82	3.59	2.61	11.43	0.29	1.26	0.01	0.04	0.01	0.04	0.01	0.04	-	-	-	-
SKT1	-	-	-	-	4.87	21.32	-	-	-	-	-	-	-	-	-	-	-	-
SKT2	-	-	-	-	4.87	21.32	-	-	-	-	-	-	-	-	-	-	-	-
OT1	-	-	-	-	138.24	295.64	-	-	-	-	-	-	-	-	-	-	-	-
OT2	-	-	-	-	138.24	295.64	-	-	-	-	-	-	-	-	-	-	-	-
OT3	-	-	-	-	138.24	295.64	-	-	-	-	-	-	-	-	-	-	-	-
OT4	-	-	-	-	138.24	295.64	-	-	-	-	-	-	-	-	-	-	-	-
WT1	-	-	-	-	0.11	0.47	-	-	-	-	-	-	-	-	-	-	-	-
WT2	-	-	-	-	0.11	0.47	-	-	-	-	-	-	-	-	-	-	-	-
DEHY1	-	-	-	-	43.51	190.56	-	-	-	-	-	-	-	-	-	-	-	-
DEHY2	-	-	-	-	43.51	190.56	-	-	-	-	-	-	-	-	-	-	-	-
DEHY3	-	-	-	-	43.51	190.56	-	-	-	-	-	-	-	-	-	-	-	-
LPS	-	-	-	-	698.88	354.13	-	-	-	-	-	-	-	-	-	-	-	-
LOAD	-	-	-	-	65.70	11.14	-	-	-	-	-	-	-	-	-	-	-	-
FUG	-	-	-	-	4.89	21.43	-	-	-	-	-	-	-	-	-	-	-	-
SSM	-	-	-	-	-	10.00	-	-	-	-	-	-	-	-	-	-	-	-
ROAD	-	-	-	-	-	-	-	-	0.15	0.02	0.15	0.02	0.15	0.02	-	-	-	-
MALFUNCTION	-	-	-	-	-	10.00	-	-	-	-	-	-	-	-	-	-	-	-
<b>Totals</b>	<b>43.11</b>	<b>188.84</b>	<b>322.11</b>	<b>1410.82</b>	<b>1563.54</b>	<b>2625.34</b>	<b>4.42</b>	<b>19.37</b>	<b>-</b>	<b>-</b>	<b>3.73</b>	<b>16.32</b>	<b>3.73</b>	<b>16.32</b>	<b>-</b>	<b>-</b>	<b>-</b>	<b>-</b>

<sup>1</sup> Condensable Particulate Matter: Include condensable particulate matter emissions for PM10 and PM2.5 if the source is a combustion source. Do not include condensable particulate matter for PM unless PM is set equal to PM10 and PM2.5. Particulate matter (PM) is not subject to an ambient air quality standard, but it is a regulated air pollutant under PSD (20.2.74 NMAC) and Title V (20.2.70 NMAC).

**Table 2-E: Requested Allowable Emissions**

Unit & stack numbering must be consistent throughout the application package. Fill all cells in this table with the emission numbers or a "-" symbol. A "--" symbol indicates that emissions of this pollutant are not expected. Numbers shall be expressed to at least 2 decimal points (e.g. 0.41, 1.41, or 1.41E<sup>-4</sup>).

Unit No.	NOx		CO		VOC		SOx		PM <sup>1</sup>		PM10 <sup>1</sup>		PM2.5 <sup>1</sup>		H <sub>2</sub> S		Lead	
	lb/hr	ton/yr	lb/hr	ton/yr	lb/hr	ton/yr	lb/hr	ton/yr	lb/hr	ton/yr	lb/hr	ton/yr	lb/hr	ton/yr	lb/hr	ton/yr	lb/hr	ton/yr
ENG1	4.13	18.11	4.38	19.21	3.47	15.18	0.42	1.84	0.38	1.65	0.38	1.65	0.38	1.65	-	-	-	-
ENG2	4.13	18.11	4.38	19.21	3.47	15.18	0.42	1.84	0.38	1.65	0.38	1.65	0.38	1.65	-	-	-	-
ENG3	4.13	18.11	4.38	19.21	3.47	15.18	0.42	1.84	0.38	1.65	0.38	1.65	0.38	1.65	-	-	-	-
ENG4	4.13	18.11	4.38	19.21	3.47	15.18	0.42	1.84	0.38	1.65	0.38	1.65	0.38	1.65	-	-	-	-
ENG5	4.13	18.11	4.38	19.21	3.47	15.18	0.42	1.84	0.38	1.65	0.38	1.65	0.38	1.65	-	-	-	-
ENG6	4.13	18.11	4.38	19.21	3.47	15.18	0.42	1.84	0.38	1.65	0.38	1.65	0.38	1.65	-	-	-	-
ENG7	4.13	18.11	4.38	19.21	3.47	15.18	0.42	1.84	0.38	1.65	0.38	1.65	0.38	1.65	-	-	-	-
ENG8	4.13	18.11	4.38	19.21	3.47	15.18	0.42	1.84	0.38	1.65	0.38	1.65	0.38	1.65	-	-	-	-
ENG9	4.13	18.11	4.38	19.21	3.47	15.18	0.42	1.84	0.38	1.65	0.38	1.65	0.38	1.65	-	-	-	-
ENG11	1.90	8.33	1.01	4.42	1.29	5.63	0.13	0.55	0.11	0.49	0.11	0.49	0.11	0.49	-	-	-	-
ENG12	1.90	8.33	1.01	4.42	1.29	5.63	0.13	0.55	0.11	0.49	0.11	0.49	0.11	0.49	-	-	-	-
HTR1	0.11	0.50	0.10	0.42	0.01	0.03	0.01	0.04	0.01	0.04	0.01	0.04	0.01	0.04	-	-	-	-
RB1	0.31	1.34	0.26	1.12	0.02	0.07	0.03	0.12	0.02	0.10	0.02	0.10	0.02	0.10	-	-	-	-
RB2	0.31	1.34	0.26	1.12	0.02	0.07	0.03	0.12	0.02	0.10	0.02	0.10	0.02	0.10	-	-	-	-
RB3	0.31	1.34	0.26	1.12	0.02	0.07	0.03	0.12	0.02	0.10	0.02	0.10	0.02	0.10	-	-	-	-
FL1-FL2 Pilot	0.67	2.93	1.33	5.84	0.94	4.13	0.01	0.03	0.03	0.13	0.03	0.13	0.03	0.13	-	-	-	-
FL1-FL2 Norm	1.85	7.72	3.69	15.41	11.53	25.60	0.01	0.04	0.03	0.15	0.03	0.15	0.03	0.15	-	-	-	-
VC1	0.41	1.80	0.82	3.59	2.61	11.43	0.29	1.26	0.01	0.04	0.01	0.04	0.01	0.04	-	-	-	-
SKT1	Emissions Represented at FL1-FL2																	
SKT2	Emissions Represented at FL1-FL2																	
OT1	Emissions Represented at FL1-FL2																	
OT2	Emissions Represented at FL1-FL2																	
OT3	Emissions Represented at FL1-FL2																	
OT4	Emissions Represented at FL1-FL2																	
WT1	Emissions Represented at FL1-FL2																	
WT2	Emissions Represented at FL1-FL2																	
DEHY1	Emissions Represented at VC1																	
DEHY2	Emissions Represented at VC1																	
DEHY3	Emissions Represented at VC1																	
LPS	Emissions Represented at FL1-FL2																	
LOAD	-	-	-	-	65.70	11.14	-	-	-	-	-	-	-	-	-	-	-	-
FUG	-	-	-	-	4.89	21.43	-	-	-	-	-	-	-	-	-	-	-	-
ROAD	-	-	-	-	-	-	-	-	0.15	0.02	0.15	0.02	0.15	0.02	-	-	-	-
MALFUNCTION	-	-	-	-	-	10.00	-	-	-	-	-	-	-	-	-	-	-	-
<b>Totals</b>	44.96	196.56	48.19	210.32	119.50	221.88	4.43	19.41	3.91	16.49	3.91	16.49	3.91	16.49	-	-	-	-

<sup>1</sup> **Condensable Particulate Matter:** Include condensable particulate matter emissions for PM10 and PM2.5 if the source is a combustion source. Do not include condensable particulate matter for PM unless PM is set equal to PM10 and PM2.5. Particulate matter (PM) is not subject to an ambient air quality standard, but it is a regulated air pollutant under PSD (20.2.74 NMAC) and Title V (20.2.70 NMAC).

**Table 2-F: Additional Emissions during Startup, Shutdown, and Routine Maintenance (SSM)**

□ This table is intentionally left blank since all emissions at this facility due to routine or predictable startup, shutdown, or scheduled maintenance are no higher than those listed in Table 2-E and a malfunction emission limit is not already permitted or requested. If you are required to report GHG emissions as described in Section 6a, include any GHG emissions during Startup, Shutdown, and/or Scheduled Maintenance (SSM) in Table 2-P. Provide an explanations of SSM emissions in Section 6 and 6a.

All applications for facilities that have emissions during routine or predictable startup, shutdown or scheduled maintenance (SSM)<sup>1</sup>, including NOI applications, must include in this table the Maximum Emissions during routine or predictable startup, shutdown and scheduled maintenance (20.2.7 NMAC, 20.2.72.203.A.3 NMAC, 20.2.73.200.D.2 NMAC). In Section 6 and 6a, provide emissions calculations for all SSM emissions reported in this table. Refer to "Guidance for Submittal of Startup, Shutdown, Maintenance Emissions in Permit Applications ([https://www.env.nm.gov/aqb/permit/aqb\\_pol.html](https://www.env.nm.gov/aqb/permit/aqb_pol.html)) for more detailed instructions. Numbers shall be expressed to at least 2 decimal points (e.g. 0.41, 1.41, or 1.41E-4).

Unit No.	NOx		CO		VOC		SOx		PM <sup>2</sup>		PM10 <sup>2</sup>		PM2.5 <sup>2</sup>		H <sub>2</sub> S		Lead	
	lb/hr	ton/yr	lb/hr	ton/yr	lb/hr	ton/yr	lb/hr	ton/yr	lb/hr	ton/yr	lb/hr	ton/yr	lb/hr	ton/yr	lb/hr	ton/yr	lb/hr	ton/yr
SSM	-	-	-	-	-	10.00												
FL1-FL2 SSM	541.65	8.10	1081.35	16.17	992.97	18.36	4.91	0.08	22.25	0.31	22.25	0.31	22.25	0.31	-	-	-	-
<b>Totals</b>	541.65	8.10	1081.35	16.17	992.97	28.36	4.91	0.08	22.25	0.31	22.25	0.31	22.25	0.31				

<sup>1</sup> For instance, if the short term steady-state Table 2-E emissions are 5 lb/hr and the SSM rate is 12 lb/hr, enter 7 lb/hr in this table. If the annual steady-state Table 2-E emissions are 21.9 TPY, and the number of scheduled SSM events result in annual emissions of 31.9 TPY, enter 10.0 TPY in the table below.

<sup>2</sup> **Condensable Particulate Matter:** Include condensable particulate matter emissions for PM10 and PM2.5 if the source is a combustion source. Do not include condensable particulate matter for PM unless PM is set equal to PM10 and PM2.5. Particulate matter (PM) is not subject to an ambient air quality standard, but it is a regulated air pollutant under PSD (20.2.74 NMAC) and Title V (20.2.70 NMAC).

**Table 2-G: Stack Exit and Fugitive Emission Rates for Special Stacks**

I have elected to leave this table blank because this facility does not have any stacks/vents that split emissions from a single source or combine emissions from more than one source listed in table 2-A. Additionally, the emission rates of all stacks match the Requested allowable emission rates stated in Table 2-E.

Use this table to list stack emissions (requested allowable) from split and combined stacks. List Toxic Air Pollutants (TAPs) and Hazardous Air Pollutants (HAPs) in Table 2-I. List all fugitives that are associated with the normal, routine, and non-emergency operation of the facility. Unit and stack numbering must correspond throughout the application package. Refer to Table 2-E for instructions on use of the “-” symbol and on significant figures.

Stack No.	Serving Unit Number(s) from Table 2-A	NOx		CO		VOC		SOx		PM		PM10		PM2.5		☐ H <sub>2</sub> S or ☐ Lead	
		lb/hr	ton/yr	lb/hr	ton/yr	lb/hr	ton/yr	lb/hr	ton/yr	lb/hr	ton/yr	lb/hr	ton/yr	lb/hr	ton/yr	lb/hr	ton/yr
<b>Totals:</b>		0.00	0.00	0.00	0.00	0.00	0.00	0.00	0.00	0.00	0.00	0.00	0.00				

**Table 2-H: Stack Exit Conditions**

Unit and stack numbering must correspond throughout the application package. Include the stack exit conditions for each unit that emits from a stack, including blowdown venting parameters and tank emissions.

Stack Number	Serving Unit Number(s) from Table 2-A	Orientation (H=Horizontal V=Vertical)	Rain Caps (Yes or No)	Height Above Ground (ft)	Temp. (F)	Flow Rate		Moisture by Volume (%)	Velocity (ft/sec)	Inside Diameter (ft)
						(acfs)	(dscfs)			
ENG1	ENG1	V	No	25	809	523.40	Unknown	Unknown	296.18	1.50
ENG2	ENG2	V	No	25	809	523.40	Unknown	Unknown	296.18	1.50
ENG3	ENG3	V	No	25	809	523.40	Unknown	Unknown	296.18	1.50
ENG4	ENG4	V	No	25	809	523.40	Unknown	Unknown	296.18	1.50
ENG5	ENG5	V	No	25	809	523.40	Unknown	Unknown	296.18	1.50
ENG6	ENG6	V	No	25	809	523.40	Unknown	Unknown	296.18	1.50
ENG7	ENG7	V	No	25	809	523.40	Unknown	Unknown	296.18	1.50
ENG8	ENG8	V	No	25	809	523.40	Unknown	Unknown	296.18	1.50
ENG9	ENG9	V	No	25	809	523.40	Unknown	Unknown	296.18	1.50
ENG11	ENG11	V	No	20	997	135.13	Unknown	Unknown	172.06	1.00
ENG12	ENG12	V	No	20	997	135.13	Unknown	Unknown	172.06	1.00
HTR1	HTR1	V	N	15	800	5.07	Unknown	Unknown	6.45	0.75
RB1	RB1	V	N	15	800	13.52	Unknown	Unknown	7.65	1.00
RB2	RB2	V	N	15	800	13.52	Unknown	Unknown	7.65	1.00
RB3	RB3	V	N	15	800	13.52	Unknown	Unknown	7.65	1.00
FL1	FL1	V	No	145	1832	4123.47	Unknown	Unknown	65.60	0.83
FL2	FL2	V	No	145	1832	4123.47	Unknown	Unknown	65.60	0.83
VC1	VC1	V	No	20	1000	1331.91	Unknown	Unknown	65.60	1.00

**Table 2-I: Stack Exit and Fugitive Emission Rates for HAPs and TAPs**

In the table below, report the Potential to Emit for each HAP from each regulated emission unit listed in Table 2-A, only if the entire facility emits the HAP at a rate greater than or equal to one (1) ton per year. For each such emission unit, HAPs shall be reported to the nearest 0.1 tpy. Each facility-wide Individual HAP total and the facility-wide Total HAPs shall be the sum of all HAP sources calculated to the nearest 0.1 ton per year. Per 20.2.72.403.A.1 NMAC, facilities not exempt [see 20.2.72.402.C NMAC] from TAP permitting shall report each TAP that has an uncontrolled emission rate in excess of its pounds per hour screening level specified in 20.2.72.502 NMAC. TAPs shall be reported using one more significant figure than the number of significant figures shown in the pound per hour threshold corresponding to the substance. Use the HAP nomenclature as it appears in Section 112 (b) of the 1990 CAAA and the TAP nomenclature as it listed in 20.2.72.502 NMAC. Include tank-flashing emissions estimates of HAPs in this table. For each HAP or TAP listed, fill all cells in this table with the emission numbers or a "-" symbol. A "-" symbol indicates that emissions of this pollutant are not expected or the pollutant is emitted in a quantity less than the threshold amounts described above.

Stack No.	Unit No.(s)	Total HAPs		Formaldehyde <input checked="" type="checkbox"/> HAP or <input type="checkbox"/> TAP		n-Hexane <input checked="" type="checkbox"/> HAP or <input type="checkbox"/> TAP		Benzene <input checked="" type="checkbox"/> HAP or <input type="checkbox"/> TAP		Acetaldehyde <input checked="" type="checkbox"/> HAP or <input type="checkbox"/> TAP		Provide Pollutant Name Here <input type="checkbox"/> HAP or <input type="checkbox"/> TAP		Provide Pollutant Name Here <input type="checkbox"/> HAP or <input type="checkbox"/> TAP		Provide Pollutant Name Here <input type="checkbox"/> HAP or <input type="checkbox"/> TAP		Provide Pollutant Name Here <input type="checkbox"/> HAP or <input type="checkbox"/> TAP	
		lb/hr	ton/yr	lb/hr	ton/yr	lb/hr	ton/yr	lb/hr	ton/yr	lb/hr	ton/yr	lb/hr	ton/yr	lb/hr	ton/yr	lb/hr	ton/yr	lb/hr	ton/yr
ENG1	ENG1	0.54	2.36	0.4	1.9	-	-	-	-	0.1	0.5								
ENG2	ENG2	0.54	2.36	0.4	1.9	-	-	-	-	0.1	0.5								
ENG3	ENG3	0.54	2.36	0.4	1.9	-	-	-	-	0.1	0.5								
ENG4	ENG4	0.54	2.36	0.4	1.9	-	-	-	-	0.1	0.5								
ENG5	ENG5	0.54	2.36	0.4	1.9	-	-	-	-	0.1	0.5								
ENG6	ENG6	0.54	2.36	0.4	1.9	-	-	-	-	0.1	0.5								
ENG7	ENG7	0.54	2.36	0.4	1.9	-	-	-	-	0.1	0.5								
ENG8	ENG8	0.54	2.36	0.4	1.9	-	-	-	-	0.1	0.5								
ENG9	ENG9	0.54	2.36	0.4	1.9	-	-	-	-	0.1	0.5								
ENG11	ENG11	0.32	1.39	0.3	1.2	-	-	-	-	0.0	0.1								
ENG12	ENG12	0.32	1.39	0.3	1.2	-	-	-	-	0.0	0.1								
HTR1	HTR1	2.2E-03	0.01	0.0	0.0	0.0	0.0	0.0	0.0	0.0	0.0								
RB1	RB1	0.01	0.03	0.0	0.0	0.0	0.0	0.0	0.0	0.0	0.0								
RB1	RB2	0.01	0.03	0.0	0.0	0.0	0.0	0.0	0.0	0.0	0.0								
RB1	RB3	0.01	0.03	0.0	0.0	0.0	0.0	0.0	0.0	0.0	0.0								
FL1-FL2 Pilot	FL1-FL2 Pilot	0.01	0.04	-	-	0.0	0.0	4.9E-04	2.2E-03	-	-								
FL1-FL2 Norm	FL1-FL2 Norm	0.5	1.1	-	-	0.4	0.9	0.0	0.1	-	-								
FL1-FL2 SSM	FL1-FL2 SSM	27.5	0.5	-	-	24.3	0.5	1.3	0.0	-	-								
VC1	DEHY1	0.1	0.5	-	-	0.0	0.1	0.1	0.2	-	-								
VC1	DEHY2	0.1	0.5	-	-	0.0	0.1	0.1	0.2	-	-								
VC1	DEHY3	0.1	0.5	-	-	0.0	0.1	0.1	0.2	-	-								

Stack No.	Unit No.(s)	Total HAPs		Formaldehyde <input checked="" type="checkbox"/> HAP or <input type="checkbox"/> TAP		n-Hexane <input checked="" type="checkbox"/> HAP or <input type="checkbox"/> TAP		Benzene <input checked="" type="checkbox"/> HAP or <input type="checkbox"/> TAP		Acetaldehyde <input checked="" type="checkbox"/> HAP or <input type="checkbox"/> TAP		Provide Pollutant Name Here <input type="checkbox"/> HAP or <input type="checkbox"/> TAP		Provide Pollutant Name Here <input type="checkbox"/> HAP or <input type="checkbox"/> TAP		Provide Pollutant Name Here <input type="checkbox"/> HAP or <input type="checkbox"/> TAP		Provide Pollutant Name Here <input type="checkbox"/> HAP or <input type="checkbox"/> TAP			
		lb/hr	ton/yr	lb/hr	ton/yr	lb/hr	ton/yr	lb/hr	ton/yr	lb/hr	ton/yr	lb/hr	ton/yr	lb/hr	ton/yr	lb/hr	ton/yr	lb/hr	ton/yr		
FL1-FL2	SKT1	Emissions Represented at FL1-FL2																			
FL1-FL2	SKT2	Emissions Represented at FL1-FL2																			
FL1-FL2	OT1	Emissions Represented at FL1-FL2																			
FL1-FL2	OT2	Emissions Represented at FL1-FL2																			
FL1-FL2	OT3	Emissions Represented at FL1-FL2																			
FL1-FL2	OT4	Emissions Represented at FL1-FL2																			
FL1-FL2	WT1	Emissions Represented at FL1-FL2																			
FL1-FL2	WT2	Emissions Represented at FL1-FL2																			
FL1-FL2	LPS	Emissions Represented at FL1-FL2																			
LOAD	LOAD	0.0	0.0	-	-	-	-	-	-	-	-										
FUG	FUG	0.4	1.6	-	-	0.09	0.39	0.04	0.17	-	-										
SSM	SSM	-	-	-	-	-	-	-	-	-	-										
ROAD	ROAD	-	-	-	-	-	-	-	-	-	-										
<b>Totals:</b>		34.2	28.8	4.4	19.4	24.9	2.2	1.6	1.0	1.0	4.6										



**Table 2-J: Fuel**

Specify fuel characteristics and usage. Unit and stack numbering must correspond throughout the application package.

Unit No.	Fuel Type (low sulfur Diesel, ultra low sulfur diesel, Natural Gas, Coal, ...)	Fuel Source: purchased commercial, pipeline quality natural gas, residue gas, raw/field natural gas, process gas (e.g. SRU tail gas) or other	Specify Units				
			Lower Heating Value (btu/scf)	Hourly Usage (scf)	Annual Usage (mmscf)	% Sulfur	% Ash
ENG1	Natural Gas	Field Gas	1154	32394.2	283.77	Negligible	0
ENG2	Natural Gas	Field Gas	1154	32394.2	283.77	Negligible	0
ENG3	Natural Gas	Field Gas	1154	32394.2	283.77	Negligible	0
ENG4	Natural Gas	Field Gas	1154	32394.2	283.77	Negligible	0
ENG5	Natural Gas	Field Gas	1154	32394.2	283.77	Negligible	0
ENG6	Natural Gas	Field Gas	1154	32394.2	283.77	Negligible	0
ENG7	Natural Gas	Field Gas	1154	32394.2	283.77	Negligible	0
ENG8	Natural Gas	Field Gas	1154	32394.2	283.77	Negligible	0
ENG9	Natural Gas	Field Gas	1154	32394.2	283.77	Negligible	0
ENG11	Natural Gas	Field Gas	1154	9681.1	84.81	Negligible	0
ENG12	Natural Gas	Field Gas	1154	9681.1	84.81	Negligible	0
HTR1	Natural Gas	Field Gas	1154	590.9	5.18	Negligible	0
RB1	Natural Gas	Field Gas	1154	1575.7	13.80	Negligible	0
RB2	Natural Gas	Field Gas	1154	1575.7	13.80	Negligible	0
RB3	Natural Gas	Field Gas	1154	1575.7	13.80	Negligible	0
FL1	Natural Gas	Field Gas	1154	1906.3	16.70	Negligible	0
FL2	Natural Gas	Field Gas	1154	1906.3	16.70	Negligible	0
VC1	Natural Gas	Field Gas	1154	3812.5	33.40	Negligible	0

**Table 2-K: Liquid Data for Tanks Listed in Table 2-L**

For each tank, list the liquid(s) to be stored in each tank. If it is expected that a tank may store a variety of hydrocarbon liquids, enter "mixed hydrocarbons" in the Composition column for that tank and enter the corresponding data of the most volatile liquid to be stored in the tank. If tank is to be used for storage of different materials, list all the materials in the "All Calculations" attachment, run the newest version of TANKS on each, and use the material with the highest emission rate to determine maximum uncontrolled and requested allowable emissions rate. The permit will specify the most volatile category of liquids that may be stored in each tank. Include appropriate tank-flashing modeling input data. Use additional sheets if necessary. Unit and stack numbering must correspond throughout the application package.

Tank No.	SCC Code	Material Name	Composition	Liquid Density (lb/gal)	Vapor Molecular Weight (lb/lb*mol)	Average Storage Conditions		Max Storage Conditions	
						Temperature (°F)	True Vapor Pressure (psia)	Temperature (°F)	True Vapor Pressure (psia)
SKT1	40400311	Produced Water	Produced Water	8.2	50	72.74	11.14	82.04	12.88
SKT2	40400311	Produced Water	Produced Water	8.2	50	72.74	11.14	82.04	12.88
OT1	40400311	Condensate	Condensate	6.6	55	69.43	9.14	78.60	10.63
OT2	40400311	Condensate	Condensate	6.6	55	69.43	9.14	78.60	10.63
OT3	40400311	Condensate	Condensate	6.6	55	69.43	9.14	78.60	10.63
OT4	40400311	Condensate	Condensate	6.6	55	69.43	9.14	78.60	10.63
WT1	40400315	Produced Water	Produced Water	8.2	0	73.51	12.87	82.69	14.43
WT2	40400315	Produced Water	Produced Water	8.2	0	73.51	12.87	82.69	14.43

**Table 2-L: Tank Data**

Include appropriate tank-flashing modeling input data. Use an addendum to this table for unlisted data categories. Unit and stack numbering must correspond throughout the application package. Use additional sheets if necessary. See reference Table 2-L2. Note: 1.00 bbl = 10.159 M3 = 42.0 gal

Tank No.	Date Installed	Materials Stored	Seal Type (refer to Table 2-LR below)	Roof Type (refer to Table 2-LR below)	Capacity		Diameter (M)	Vapor Space (M)	Color (from Table VI-C)		Paint Condition (from Table VI-C)	Annual Throughput (gal/yr)	Turn-overs (per year)
					(bbl)	(M <sup>3</sup> )			Roof	Shell			
SKT1	Sep-20	Produced Water	N/A	FX	1000 bbl	159	4.75	9.1	Tan	Tan	Good	2,660,433	63
SKT2	TBD	Produced Water	N/A	FX	1000 bbl	159	4.75	9.1	Tan	Tan	Good	2,660,433	63
OT1	Sep-20	Condensate	N/A	FX	500 bbl	79.5	3.66	4.9	Tan	Tan	Good	3,120,436	149
OT2	Sep-20	Condensate	N/A	FX	500 bbl	79.5	3.66	4.9	Tan	Tan	Good	3,120,436	149
OT3	Sep-20	Condensate	N/A	FX	500 bbl	79.5	3.66	4.9	Tan	Tan	Good	3,120,436	149
OT4	Sep-20	Condensate	N/A	FX	500 bbl	79.5	3.66	4.9	Tan	Tan	Good	3,120,436	149
WT1	Sep-20	Produced Water	N/A	FX	500 bbl	79.5	3.66	4.9	Tan	Tan	Good	2,614,573	125
WT2	Sep-20	Produced Water	N/A	FX	500 bbl	79.5	3.66	4.9	Tan	Tan	Good	2,614,573	125

**Table 2-L2: Liquid Storage Tank Data Codes Reference Table**

Roof Type	Seal Type, Welded Tank Seal Type		Seal Type, Riveted Tank Seal Type		Roof, Shell Color	Paint Condition
FX: Fixed Roof	Mechanical Shoe Seal	Liquid-mounted resilient seal	Vapor-mounted resilient seal	Seal Type	WH: White	Good
IF: Internal Floating Roof	A: Primary only	A: Primary only	A: Primary only	A: Mechanical shoe, primary only	AS: Aluminum (specular)	Poor
EF: External Floating Roof	B: Shoe-mounted secondary	B: Weather shield	B: Weather shield	B: Shoe-mounted secondary	AD: Aluminum (diffuse)	
P: Pressure	C: Rim-mounted secondary	C: Rim-mounted secondary	C: Rim-mounted secondary	C: Rim-mounted secondary	LG: Light Gray	
					MG: Medium Gray	
					BL: Black	
					OT: Other (specify)	

Note: 1.00 bbl = 0.159 M<sup>3</sup> = 42.0 gal

**Table 2-M: Materials Processed and Produced** (Use additional sheets as necessary.)

Material Processed				Material Produced			
Description	Chemical Composition	Phase (Gas, Liquid, or Solid)	Quantity (specify units)	Description	Chemical Composition	Phase	Quantity (specify units)
Mixed Hydrocarbons	Oil (BOPD)	Liquid	814	Mixed Hydrocarbons	Oil (BOPD)	Liquid	814
	Produced Water (BWPD)	Liquid	341		Produced Water (BWPD)	Liquid	341
	Natural Gas (MMSCFD)	Gas	240		Natural Gas (MMSCFD)	Gas	240

**Table 2-N: CEM Equipment**

Enter Continuous Emissions Measurement (CEM) Data in this table. If CEM data will be used as part of a federally enforceable permit condition, or used to satisfy the requirements of a state or federal regulation, include a copy of the CEM's manufacturer specification sheet in the Information Used to Determine Emissions attachment. Unit and stack numbering must correspond throughout the application package. Use additional sheets if necessary.

Stack No.	Pollutant(s)	Manufacturer	Model No.	Serial No.	Sample Frequency	Averaging Time	Range	Sensitivity	Accuracy
N/A									

**Table 2-O: Parametric Emissions Measurement Equipment**

Unit and stack numbering must correspond throughout the application package. Use additional sheets if necessary.

Unit No.	Parameter/Pollutant Measured	Location of Measurement	Unit of Measure	Acceptable Range	Frequency of Maintenance	Nature of Maintenance	Method of Recording	Averaging Time
N/A								

**Table 2-P: Greenhouse Gas Emissions**

Applications submitted under 20.2.70, 20.2.72, & 20.2.74 NMAC are required to complete this Table. Power plants, Title V major sources, and PSD major sources must report and calculate all GHG emissions for each unit. Applicants must report potential emission rates in short tons per year (see Section 6.a for assistance). Include GHG emissions during Startup, Shutdown, and Scheduled Maintenance in this table. For minor source facilities that are not power plants, are not Title V, or are not PSD, there are three options for reporting GHGs 1) report GHGs for each individual piece of equipment; 2) report all GHGs from a group of unit types, for example report all combustion source GHGs as a single unit and all venting GHG as a second separate unit; OR 3) check the following box  By checking this box, the applicant acknowledges the total CO<sub>2</sub>e emissions are less than 75,000 tons per year.

		CO <sub>2</sub> ton/yr	N <sub>2</sub> O ton/yr	CH <sub>4</sub> ton/yr	SF <sub>6</sub> ton/yr	PFC/HFC ton/yr <sup>2</sup>										Total GHG Mass Basis ton/yr <sup>4</sup>	Total CO <sub>2</sub> e ton/yr <sup>5</sup>
<b>Unit No.</b>	<b>GWPs<sup>1</sup></b>	<b>1</b>	<b>298</b>	<b>25</b>	<b>22,800</b>	<b>footnote 3</b>											
ENG1	mass GHG	21967.59	0.04	0.36												21968.0	
	CO <sub>2</sub> e	21967.593	10.758167	9.0253076													21987.4
ENG2	mass GHG	21967.59	0.04	0.36												21968.0	
	CO <sub>2</sub> e	21967.59	10.76	9.03													21987.4
ENG3	mass GHG	21967.59	0.04	0.36												21968.0	
	CO <sub>2</sub> e	21967.593	10.758167	9.0253076													5000000.0
ENG4	mass GHG	21967.59	0.04	0.36												21968.0	
	CO <sub>2</sub> e	21967.59	10.76	9.03													21987.4
ENG5	mass GHG	21967.59	0.04	0.36												21968.0	
	CO <sub>2</sub> e	21967.593	10.758167	9.0253076													21987.4
ENG6	mass GHG	21967.59	0.04	0.36												21968.0	
	CO <sub>2</sub> e	21967.59	10.76	9.03													21987.4
ENG7	mass GHG	21967.59	0.04	0.36												21968.0	
	CO <sub>2</sub> e	21967.593	10.758167	9.0253076													21987.4
ENG8	mass GHG	21967.59	0.04	0.36												21968.0	
	CO <sub>2</sub> e	21967.59	10.76	9.03													21987.4
ENG9	mass GHG	21967.59	0.04	0.36												21968.0	
	CO <sub>2</sub> e	21967.593	10.758167	9.0253076													21987.4
ENG11	mass GHG	6689.35	0.01	0.11												6689.5	
	CO <sub>2</sub> e	6689.35	3.22	2.70													6695.3
ENG12	mass GHG	6689.35	0.01	0.11												6689.5	
	CO <sub>2</sub> e	6689.3492	3.2151031	2.6972342													6695.3
HTR1	mass GHG	519.34	0.00	0.32												519.7	
	CO <sub>2</sub> e	519.34	0.22	7.95													527.5
RB1	mass GHG	1384.91	0.00	0.85												1385.8	
	CO <sub>2</sub> e	1384.9065	0.5755123	21.209347													1406.7
RB2	mass GHG	1384.91	0.00	0.85												1385.8	
	CO <sub>2</sub> e	1384.91	0.58	21.21													1406.7
RB3	mass GHG	1384.91	0.00	0.85												1385.8	
	CO <sub>2</sub> e	1384.9065	0.5755123	21.209347													1406.7
FL1	mass GHG	10445.31	0.01	12.77												10458.1	
	CO <sub>2</sub> e	10445.31	4.46	319.35													10769.1
FL2	mass GHG	10445.31	0.01	12.77												10458.1	
	CO <sub>2</sub> e	10445.308	4.4619051	319.35375													10769.1
VC1	mass GHG	20890.62	0.03	25.55												20916.2	
	CO <sub>2</sub> e	20890.62	8.92	638.71													21538.2
<b>Total</b>	mass GHG	257,542	0	57												257,600	
	CO <sub>2</sub> e	257,542	123	1,436													259,101

<sup>1</sup> GWP (Global Warming Potential): Applicants must use the most current GWPs codified in Table A-1 of 40 CFR part 98. GWPs are subject to change, therefore, applicants need to check 40 CFR 98 to confirm GWP values.

<sup>2</sup> For HFCs or PFCs describe the specific HFC or PFC compound and use a separate column for each individual compound.

<sup>3</sup> For each new compound, enter the appropriate GWP for each HFC or PFC compound from Table A-1 in 40 CFR 98.

<sup>4</sup> Green house gas emissions on a mass basis is the ton per year green house gas emission before adjustment with its GWP.

<sup>5</sup> CO<sub>2</sub>e means Carbon Dioxide Equivalent and is calculated by multiplying the TPY mass emissions of the green house gas by its GWP.

<sup>6</sup> For Heaters/Boilers, CO<sub>2</sub> CH<sub>4</sub>, N<sub>2</sub>O emissions calculated according to §98.233(z)(1) and (2).

**Tab 3**  
**Section 3 - Application Summary**



# Section 3

## Application Summary

---

The **Application Summary** shall include a brief description of the facility and its process, the type of permit application, the applicable regulation (i.e. 20.2.72.200.A.X, or 20.2.73 NMAC) under which the application is being submitted, and any air quality permit numbers associated with this site. If this facility is to be collocated with another facility, provide details of the other facility including permit number(s). In case of a revision or modification to a facility, provide the lowest level regulatory citation (i.e. 20.2.72.219.B.1.d NMAC) under which the revision or modification is being requested. Also describe the proposed changes from the original permit, how the proposed modification will affect the facility's operations and emissions, de-bottlenecking impacts, and changes to the facility's major/minor status (both PSD & Title V).

The **Process Summary** shall include a brief description of the facility and its processes.

**Startup, Shutdown, and Maintenance (SSM) routine or predictable emissions:** Provide an overview of how SSM emissions are accounted for in this application. Refer to "Guidance for Submittal of Startup, Shutdown, Maintenance Emissions in Permit Applications ([http://www.env.nm.gov/aqb/permit/app\\_form.html](http://www.env.nm.gov/aqb/permit/app_form.html)) for more detailed instructions on SSM emissions.

---

XTO Energy Inc. is planning modification of the Bulldog Compressor Station in Eddy County, NM. The facility is a typical compressor station with natural gas engines, dehydration, storage tanks, and flares. Site construction is planned under NSR Permit 8153. This is a New Source Review permit application being submitted in accordance with 20.2.72 NMAC.

Routine SSM combustion emissions are included with the regular emissions of the facility. SSM emissions from equipment maintenance are routed to either the low pressure or high pressure flare header (FL1/FL2). SSM-related VOC emissions (tank landings/cleanings) are included at a rate of 10 tons per year per NMAQB guidance. Detailed calculations are included in the application.

The facility is proposing the following modifications:

- 1) Remove HTR2 and HTR3;
- 2) Remove ENG10 and ENG13;
- 3) Increase glycol circulation rate for DEHY1-3;
- 4) Decrease glycol regenerator reboiler (RB1-RB3) unit heat input from 3 MMBtu/hr to 2.0 MMBtu/hr;
- 5) Increase flare purge gas rates;
- 6) Remove FL3;
- 7) Update FL1-FL2 heights to 145';
- 8) Update tank throughputs;
- 9) Decrease condensate truck loading;
- 10) Add inlet gas flaring;
- 11) Increasing steady state flaring associated with increased tank throughput and glycol circulation rate; update sources that vent to flare.
- 12) Change sources that vent to VC1, only combusts vapors from DEHY1-3 still vent and pilot gas.
- 13) Update ENG1-9 and ENG11-12 VOC/formaldehyde/CO control efficiencies and update emissions factors from Caterpillar Gas Engine Rating Pro (GERP) analysis.
- 14) Update nomenclature of Gb1a and GB2a to SKT1 and SKT2.
- 15) Update facility location coordinates
- 16) Update low pressure separator pressure from 2 psig to 15 psig.
- 17) Added VOC malfunction emissions.

**Tab 4**  
**Section 4 - Process Flow Sheet**

# Section 4

## Process Flow Sheet

---

A **process flow sheet** and/or block diagram indicating the individual equipment, all emission points and types of control applied to those points. The unit numbering system should be consistent throughout this application.

---

A process flow diagram is presented on the following page.

# XTO DELAWARE BASIN GEN 2 COMPRESSOR STATION

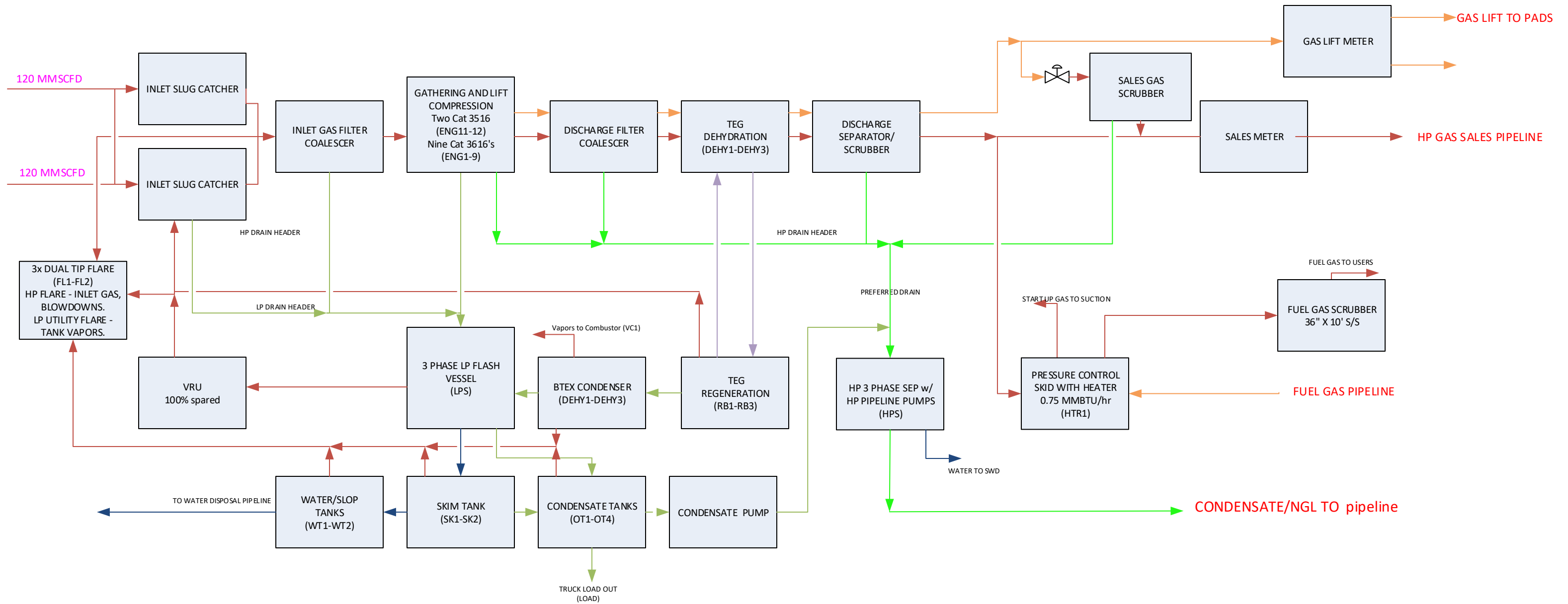

**Tab 5**  
**Section 5 - Plot Plan Drawn To Scale**

# Section 5

## Plot Plan Drawn To Scale

---

A **plot plan drawn to scale** showing emissions points, roads, structures, tanks, and fences of property owned, leased, or under direct control of the applicant. This plot plan must clearly designate the restricted area as defined in UA1, Section 1-D.12. The unit numbering system should be consistent throughout this application.

---

A proposed plot plan is presented on the following page.

G  
F  
E  
B  
A

G  
F  
E  
C  
B  
A

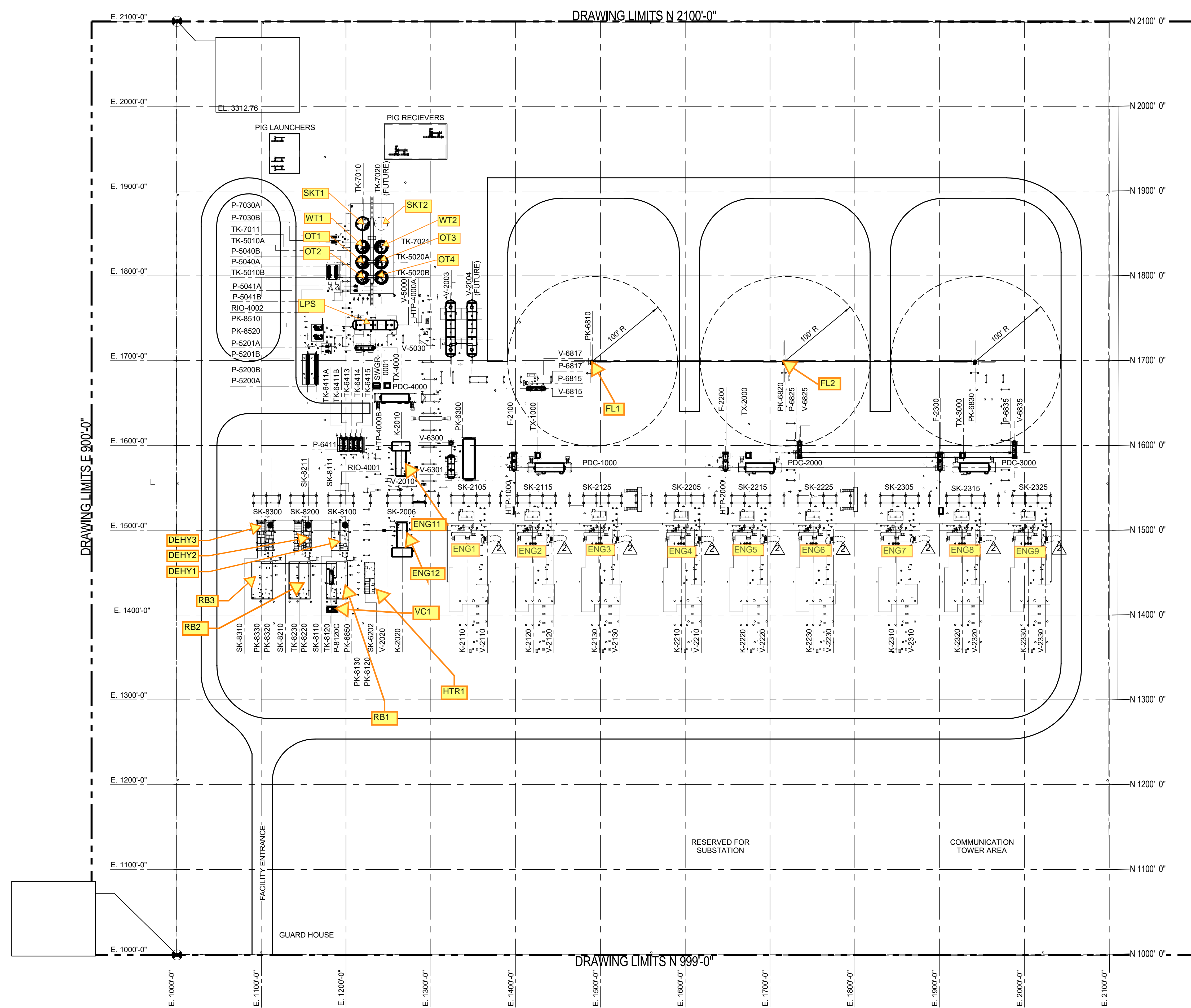

Tag	Description
K-2010	START-UP COMPRESSOR 1
K-2020	START-UP COMPRESSOR 2
K-2110	TRAIN 1 COMPRESSOR 1
K-2120	TRAIN 1 COMPRESSOR 2
K-2130	TRAIN 1 COMPRESSOR 3
K-2210	TRAIN 2 COMPRESSOR 1
K-2220	TRAIN 2 COMPRESSOR 2
K-2230	TRAIN 2 COMPRESSOR 3
K-2310	TRAIN 3 COMPRESSOR 1
K-2320	TRAIN 3 COMPRESSOR 2
K-2330	TRAIN 3 COMPRESSOR 3
P-5040A	LP CONDENSATE TRANSFER PUMP
P-5040B	LP CONDENSATE TRANSFER PUMP
P-5041A	BOOSTER PUMP
P-5041B	BOOSTER PUMP
P-5000A	CONDENSATE PIPELINE PUMP
P-5000B	CONDENSATE PIPELINE PUMP
P-5201A	CONDENSATE PIPELINE TRANSFER PUMP
P-5201B	CONDENSATE PIPELINE TRANSFER PUMP
P-6411	DAY TANK SUMP PUMP
P-6815	TRAIN 1 HP FLARE KNOCK-OUT PUMP
P-6817	TRAIN 1 LP FLARE KNOCK-OUT PUMP
P-6825	TRAIN 2 HP FLARE KNOCK-OUT PUMP
P-6835	TRAIN 3 HP FLARE KNOCK-OUT PUMP
P-7030A	PRODUCED WATER PUMP
P-7030B	PRODUCED WATER PUMP
PK-6300	INSTRUMENT AIR SKID
PK-6810	TRAIN 1 HP/LP FLARE PACKAGE
PK-6820	TRAIN 2 HP FLARE PACKAGE
PK-6830	TRAIN 3 HP FLARE PACKAGE
PK-6850	THERMAL OXIDIZER PACKAGE
PK-8130	BTEX PACKAGE
PK-8230	BTEX PACKAGE
PK-8330	BTEX PACKAGE
PK-8510	VAPOR RECOVERY UNIT
PK-8520	VAPOR RECOVERY UNIT
SK-6202	FUEL GAS SKID
SK-8110	DISCHARGE FILTER SKID
SK-8111	TEG CONTACTOR/SCRUBBER SKID
SK-8120	TEG REGEN PACKAGE TRAIN 0
SK-8210	DISCHARGE FILTER SKID
SK-8211	TEG CONTACTOR/SCRUBBER SKID
SK-8220	TEG REGEN PACKAGE TRAIN 1
SK-8310	DISCHARGE FILTER SKID
SK-8311	TEG CONTACTOR/SCRUBBER SKID
SK-8320	TEG REGEN PACKAGE TRAIN 3
TK-6411A	COMPRESSOR OIL TANK
TK-6413	ENGINE OIL TANK
TK-6414	ENGINE COOLANT TANK
TK-6415	METHANOL TANK
TK-7010	SKIM TANK
TK-8120	GLYCOL MAKE-UP TANK
V-2004	INLET SLUG CATCHER
V-2004	INLET SLUG CATCHER (FUTURE)
V-2010	START-UP COMPRESSOR 1 BLOWCASE
V-2020	START-UP COMPRESSOR 2 BLOWCASE
V-2110	TRAIN 1 COMPRESSOR 1 BLOWCASE
V-2120	TRAIN 1 COMPRESSOR 2 BLOWCASE
V-2130	TRAIN 1 COMPRESSOR 3 BLOWCASE
V-2210	TRAIN 2 COMPRESSOR 1 BLOWCASE
V-2220	TRAIN 2 COMPRESSOR 2 BLOWCASE
V-2230	TRAIN 2 COMPRESSOR 3 BLOWCASE
V-2310	TRAIN 3 COMPRESSOR 1 BLOWCASE
V-2320	TRAIN 3 COMPRESSOR 2 BLOWCASE
V-2330	TRAIN 3 COMPRESSOR 3 BLOWCASE
V-5000	LP 3-PHASE SEPARATOR
V-5030	H.P. 3-PHASE SEPARATOR
V-6300	WET AIR RECEIVER
V-6301	DRY AIR VOLUME TANK
V-6815	TRAIN 1 HP FLARE KNOCK-OUT DRUM
V-6817	TRAIN 1 LP FLARE KNOCK-OUT DRUM
V-6825	TRAIN 2 HP FLARE KNOCK-OUT DRUM
V-6835	TRAIN 3 HP FLARE KNOCK-OUT DRUM
F-2100	TRAIN 1 INLET GAS FILTER COALESCER
F-2200	TRAIN 2 INLET GAS FILTER COALESCER
F-2300	TRAIN 3 INLET GAS FILTER COALESCER
TK-5010A	CONDENSATE TANK
TK-5010B	CONDENSATE TANK
TK-5200A	CONDENSATE TANK
TK-5200B	CONDENSATE TANK
TK-7011	WATER TANK
TK-7021	WATER TANK
PDC-1000	POWER DISTRIBUTION CENTER
HTP-1000	HEAT TRACE PANEL BOARD
TX-1000	TRANSFORMER
PDC-2000	POWER DISTRIBUTION CENTER
HTP-2000	HEAT TRACE PANEL BOARD
TX-2000	TRANSFORMER
PDC-3000	POWER DISTRIBUTION CENTER
HTP-3000	HEAT TRACE PANEL BOARD
TX-3000	TRANSFORMER
PDC-4000	POWER DISTRIBUTION CENTER
HTP-4000	HEAT TRACE PANEL BOARD
TX-4000	TRANSFORMER

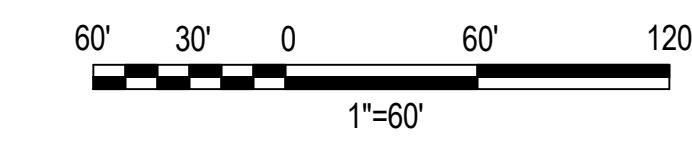

**GENERAL NOTES:**  
 1. ALL DISTANCES AND ELEVATIONS ARE EXPRESSED IN TERMS OF FEET UNLESS OTHERWISE NOTED.  
 2. FENCELINE TO BE LOCATED 1'-0" INSIDE THE BOUNDARY LIMIT, INDICATED AS "DRAWING LIMITS," FOR THE FULL PERIMETER OF THE SITE.  
 3. PREVAILING WIND BLOWS FROM THE SOUTH NORMALLY, BUT MAY ALSO BLOW FROM THE SOUTH-EAST.  
 4. LOCATION CHANGE

REV	DATE	DESCRIPTION	BY	CHK	APP
2	10-18-19	ISSUED FOR CONSTRUCTION	TWW	WRV	KTB
1	09-30-19	ISSUED FOR CONSTRUCTION	KW	RW	KTB
0	06-24-19	ISSUED FOR CONSTRUCTION	KW	RW	OA

DISCIPLINE	APP
PROCESS	
PROCESS SAFETY	
MECHANICAL	
PPING	
CIVIL/STRUCTURAL	
IBC	
ELECTRICAL	



**XTO ENERGY**  
 LONGHORN COMPRESSOR STATION  
 FACILITY PLOT PLAN

LOCATION: CARLSBAD, NM SCALE: 1"=60'  
 DRAWING NO.: LH-0301

REV. 2

**Tab 6**  
**Section 6 - All Calculations**



# Section 6

## All Calculations

---

**Show all calculations** used to determine both the hourly and annual controlled and uncontrolled emission rates. All calculations shall be performed keeping a minimum of three significant figures. Document the source of each emission factor used (if an emission rate is carried forward and not revised, then a statement to that effect is required). If identical units are being permitted and will be subject to the same operating conditions, submit calculations for only one unit and a note specifying what other units to which the calculations apply. All formulas and calculations used to calculate emissions must be submitted. The "Calculations" tab in the UA2 has been provided to allow calculations to be linked to the emissions tables. Add additional "Calc" tabs as needed. If the UA2 or other spread sheets are used, all calculation spread sheet(s) shall be submitted electronically in Microsoft Excel compatible format so that formulas and input values can be checked. Format all spread sheets and calculations such that the reviewer can follow the logic and verify the input values. Define all variables. If calculation spread sheets are not used, provide the original formulas with defined variables. Additionally, provide subsequent formulas showing the input values for each variable in the formula. All calculations, including those calculations are imbedded in the Calc tab of the UA2 portion of the application, the printed Calc tab(s), should be submitted under this section.

**Tank Flashing Calculations:** The information provided to the AQB shall include a discussion of the method used to estimate tank-flashing emissions, relative thresholds (i.e., NOI, permit, or major source (NSPS, PSD or Title V)), accuracy of the model, the input and output from simulation models and software, all calculations, documentation of any assumptions used, descriptions of sampling methods and conditions, copies of any lab sample analysis. If Hysis is used, all relevant input parameters shall be reported, including separator pressure, gas throughput, and all other relevant parameters necessary for flashing calculation.

**SSM Calculations:** It is the applicant's responsibility to provide an estimate of SSM emissions or to provide justification for not doing so. In this Section, provide emissions calculations for Startup, Shutdown, and Routine Maintenance (SSM) emissions listed in the Section 2 SSM and/or Section 22 GHG Tables and the rationale for why the others are reported as zero (or left blank in the SSM/GHG Tables). Refer to "Guidance for Submittal of Startup, Shutdown, Maintenance Emissions in Permit Applications ([http://www.env.nm.gov/aqb/permit/app\\_form.html](http://www.env.nm.gov/aqb/permit/app_form.html)) for more detailed instructions on calculating SSM emissions. If SSM emissions are greater than those reported in the Section 2, Requested Allowables Table, modeling may be required to ensure compliance with the standards whether the application is NSR or Title V. Refer to the Modeling Section of this application for more guidance on modeling requirements.

**Glycol Dehydrator Calculations:** The information provided to the AQB shall include the manufacturer's maximum design recirculation rate for the glycol pump. If GRI-Glycalc is used, the full input summary report shall be included as well as a copy of the gas analysis that was used.

**Road Calculations:** Calculate fugitive particulate emissions and enter haul road fugitives in Tables 2-A, 2-D and 2-E for:

1. If you transport raw material, process material and/or product into or out of or within the facility and have PER emissions greater than 0.5 tpy.
2. If you transport raw material, process material and/or product into or out of the facility more frequently than one round trip per day.

**Significant Figures:**

- A. All emissions standards are deemed to have at least two significant figures, but not more than three significant figures.
- B. At least 5 significant figures shall be retained in all intermediate calculations.
- C. In calculating emissions to determine compliance with an emission standard, the following rounding off procedures shall be used:
  - (1) If the first digit to be discarded is less than the number 5, the last digit retained shall not be changed;
  - (2) If the first digit discarded is greater than the number 5, or if it is the number 5 followed by at least one digit other than the number zero, the last figure retained shall be increased by one unit; **and**
  - (3) If the first digit discarded is exactly the number 5, followed only by zeros, the last digit retained shall be rounded upward if it is an odd number, but no adjustment shall be made if it is an even number.
  - (4) The final result of the calculation shall be expressed in the units of the standard.

**Control Devices:** In accordance with 20.2.72.203.A(3) and (8) NMAC, 20.2.70.300.D(5)(b) and (e) NMAC, and 20.2.73.200.B(7) NMAC, the permittee shall report all control devices and list each pollutant controlled by the control device

regardless if the applicant takes credit for the reduction in emissions. The applicant can indicate in this section of the application if they chose to not take credit for the reduction in emission rates. For notices of intent submitted under 20.2.73 NMAC, only uncontrolled emission rates can be considered to determine applicability unless the state or federal Acts require the control. This information is necessary to determine if federally enforceable conditions are necessary for the control device, and/or if the control device produces its own regulated pollutants or increases emission rates of other pollutants.

---

#### **Caterpillar 3616TA (ENG-1 to ENG-9) and 3516TA (ENG-11 to ENG-12)**

Emission factors for nitrogen oxides (NO<sub>x</sub>), carbon monoxide (CO), formaldehyde, and volatile organic compounds (VOC) are based on manufacturer's data. Emissions of particulate matter (PM/PM<sub>10</sub> and PM<sub>2.5</sub>) were calculated using AP-42 Table 3.2-3 factors. PM<sub>10</sub> and PM<sub>2.5</sub> emissions are set equal to PM emissions. SO<sub>2</sub> emissions are based on the units' fuel consumption and a sulfur content of 5 grains per 100 standard cubic feet (5 gr/100 scf). Hazardous Air Pollutants (HAPs) except for formaldehyde were calculated using AP-42 factors.

#### **Line Heater (HTR1) and Glycol Regenerator Heaters (RB1 to RB3)**

Emission of NO<sub>x</sub>, CO, VOC, HAP, and PM/PM<sub>10</sub>/PM<sub>2.5</sub> are based on AP-42 Table 3.2-3 emission factors. PM<sub>10</sub> and PM<sub>2.5</sub> emissions are set equal to PM emissions. SO<sub>2</sub> emissions were based on the unit's fuel consumption and a maximum sulfur content of 5 grains per 100 standard cubic feet (5 gr/100 scf).

#### **SSM/Emergency Flares (FL1 – FL2)**

The facility will use two (2) dual-tip flares. NO<sub>x</sub> and CO emissions are based on factors from the Texas Commission on Environmental Quality (TCEQ) publication RG-360A/09. VOC emissions were calculated using a material balance and the manufacturer's guaranteed destruction efficiency (98%). Since gas can be routed to any or all of the flares, they are illustrated as one combine emission point. The flares have a control efficiency of 98%, with manufacturer documentation provided in Section 7 of the application. SSM activities routed to the flares could include process vessel purging and maintenance blowdowns for process equipment, high pressure gas flaring, and low pressure separator gas during VRU downtime. Tank vapors and 2% of the low pressure separator gas not collected by the VRU are continuously routed to the low pressure side of the flare.

#### **Triethylene Glycol Dehydrators (DEHY1-DEHY3)**

Emissions from the dehydrators are calculated using BR&E ProMax simulation software. Flash tank vapors are routed back to mixing with the inlet gas. Each dehydrator is equipped with a condenser. Condensed liquids are routed to the skim tank and any remaining gas is burned at the vapor combustor (VC1). The emissions being released at VC1 from the dehydration process are represented as a separate emission point (DEHY1-DEHY3).

#### **Storage Tanks (SKT1-SKT2, OT1-OT4, WT1-WT2)**

Flashing, working and breathing emissions from the skim tank, oil tanks, and water tanks were calculated using BR&E ProMax simulation software. Emissions from the tanks are controlled using FL1-FL2. The simulation reports are included in Section 7.

#### **Truck Loading (LOAD)**

Uncontrolled emissions from oil loading of trucks were calculated using Equation 1 of AP-42 Section 5.2. Maximum slop oil loading rates are calculated using 814 BOPD for 100 days of the year. Relevant portions of AP-42 Section 5.2 are included in Section 7. Oil truck loading will be uncontrolled.

#### **Piping Component Fugitive Emissions (FUG)**

Facility fugitive emissions were calculated using TCEQ's "Air Permit Technical Guidance for Chemical Sources – Fugitive Guidance" document, and conservatively assumed component counts. Reduction efficiencies were obtained from EPA's Protocol for Equipment Leak Emission Estimates (EPA-453/R-95-017). Relevant portions of the TCEQ document are included in Section 7.

#### **Startup, Shutdown, and Maintenance (SSM)**

SSM emissions not routed to the flare system were assumed equal to the flat 10 tpy of VOC per State guidance. Specific SSM emissions include small equipment blowdowns, tank emptying and refilling, tank roof landing, and miscellaneous activities. Other SSM emissions are routed to the flare and calculated in accordance with the flare methodology above.

#### **Haul Road Fugitive Emissions**

Fugitive haul road emissions were calculated using Equations 1a and 2 of AP-42 Section 13.2.2. Relevant portions of AP-42 Section 13.2.2 are included in Section 7.

**Malfunction Emissions (MALFCUNTION)**

Malfunction emissions not routed to the flare system were assumed equal to the flat 10 tpy of VOC per State guidance. Specific malfunction emissions include any sudden and unavoidable failure of air pollution control equipment or process equipment beyond the control of the owner or operator.

# Section 6.a

## Green House Gas Emissions

(Submitting under 20.2.70, 20.2.72 20.2.74 NMAC)

---

**Title V (20.2.70 NMAC), Minor NSR (20.2.72 NMAC), and PSD (20.2.74 NMAC)** applicants must estimate and report greenhouse gas (GHG) emissions to verify the emission rates reported in the public notice, determine applicability to 40 CFR 60 Subparts, and to evaluate Prevention of Significant Deterioration (PSD) applicability. GHG emissions that are subject to air permit regulations consist of the sum of an aggregate group of these six greenhouse gases: carbon dioxide (CO<sub>2</sub>), nitrous oxide (N<sub>2</sub>O), methane (CH<sub>4</sub>), hydrofluorocarbons (HFCs), perfluorocarbons (PFCs), and sulfur hexafluoride (SF<sub>6</sub>).

### Calculating GHG Emissions:

1. Calculate the ton per year (tpy) GHG mass emissions and GHG CO<sub>2</sub>e emissions from your facility.
2. GHG mass emissions are the sum of the total annual tons of greenhouse gases without adjusting with the global warming potentials (GWPs). GHG CO<sub>2</sub>e emissions are the sum of the mass emissions of each individual GHG multiplied by its GWP found in Table A-1 in 40 CFR 98 Mandatory Greenhouse Gas Reporting.
3. Emissions from routine or predictable start up, shut down, and maintenance must be included.
4. Report GHG mass and GHG CO<sub>2</sub>e emissions in Table 2-P of this application. Emissions are reported in **short** tons per year and represent each emission unit's Potential to Emit (PTE).
5. All Title V major sources, PSD major sources, and all power plants, whether major or not, must calculate and report GHG mass and CO<sub>2</sub>e emissions for each unit in Table 2-P.
6. For minor source facilities that are not power plants, are not Title V, and are not PSD there are three options for reporting GHGs in Table 2-P: 1) report GHGs for each individual piece of equipment; 2) report all GHGs from a group of unit types, for example report all combustion source GHGs as a single unit and all venting GHGs as a second separate unit; 3) or check the following  By checking this box, the applicant acknowledges the total CO<sub>2</sub>e emissions are less than 75,000 tons per year.

### Sources for Calculating GHG Emissions:

- Manufacturer's Data
- AP-42 Compilation of Air Pollutant Emission Factors at <http://www.epa.gov/ttn/chief/ap42/index.html>
- EPA's Internet emission factor database WebFIRE at <http://cfpub.epa.gov/webfire/>
- 40 CFR 98 Mandatory Green House Gas Reporting except that tons should be reported in short tons rather than in metric tons for the purpose of PSD applicability.
- API Compendium of Greenhouse Gas Emissions Methodologies for the Oil and Natural Gas Industry. August 2009 or most recent version.
- Sources listed on EPA's NSR Resources for Estimating GHG Emissions at <http://www.epa.gov/nsr/clean-air-act-permitting-greenhouse-gases>:

### Global Warming Potentials (GWP):

Applicants must use the Global Warming Potentials codified in Table A-1 of the most recent version of 40 CFR 98 Mandatory Greenhouse Gas Reporting. The GWP for a particular GHG is the ratio of heat trapped by one unit mass of the GHG to that of one unit mass of CO<sub>2</sub> over a specified time period.

**"Greenhouse gas"** for the purpose of air permit regulations is defined as the aggregate group of the following six gases: carbon dioxide, nitrous oxide, methane, hydrofluorocarbons, perfluorocarbons, and sulfur hexafluoride. **(20.2.70.7 NMAC, 20.2.74.7 NMAC)**. You may also find GHGs defined in 40 CFR 86.1818-12(a).

### Metric to Short Ton Conversion:

Short tons for GHGs and other regulated pollutants are the standard unit of measure for PSD and title V permitting programs. 40 CFR 98 Mandatory Greenhouse Reporting requires metric tons.

1 metric ton = 1.10231 short tons (per Table A-2 to Subpart A of Part 98 – Units of Measure Conversions)

**XTO ENERGY, INC.**  
**BULLDOG COMPRESSOR STATION**  
**FACILITY EMISSIONS SUMMARY**

EMISSIONS SUMMARY TABLE

EMISSION SOURCE DESCRIPTION	FACILITY IDENTIFICATION NUMBER	STACK NUMBER	NOx		CO		VOC (INCLUDES HAPs)		SO <sub>2</sub>		PM <sub>10 &amp; 2.5</sub>		HAPs		CO <sub>2e</sub>
			lb/hr	TPY	lb/hr	TPY	lb/hr	TPY	lb/hr	TPY	lb/hr	TPY	lb/hr	TPY	TPY
Caterpillar G3616 Natural Gas Compressor Engine	ENG1	ENG1	4.13	18.11	4.38	19.21	3.47	15.18	0.42	1.84	0.38	1.65	0.54	2.36	21987
Caterpillar G3616 Natural Gas Compressor Engine	ENG2	ENG2	4.13	18.11	4.38	19.21	3.47	15.18	0.42	1.84	0.38	1.65	0.54	2.36	21987
Caterpillar G3616 Natural Gas Compressor Engine	ENG3	ENG3	4.13	18.11	4.38	19.21	3.47	15.18	0.42	1.84	0.38	1.65	0.54	2.36	21987
Caterpillar G3616 Natural Gas Compressor Engine	ENG4	ENG4	4.13	18.11	4.38	19.21	3.47	15.18	0.42	1.84	0.38	1.65	0.54	2.36	21987
Caterpillar G3616 Natural Gas Compressor Engine	ENG5	ENG5	4.13	18.11	4.38	19.21	3.47	15.18	0.42	1.84	0.38	1.65	0.54	2.36	21987
Caterpillar G3616 Natural Gas Compressor Engine	ENG6	ENG6	4.13	18.11	4.38	19.21	3.47	15.18	0.42	1.84	0.38	1.65	0.54	2.36	21987
Caterpillar G3616 Natural Gas Compressor Engine	ENG7	ENG7	4.13	18.11	4.38	19.21	3.47	15.18	0.42	1.84	0.38	1.65	0.54	2.36	21987
Caterpillar G3616 Natural Gas Compressor Engine	ENG8	ENG8	4.13	18.11	4.38	19.21	3.47	15.18	0.42	1.84	0.38	1.65	0.54	2.36	21987
Caterpillar G3616 Natural Gas Compressor Engine	ENG9	ENG9	4.13	18.11	4.38	19.21	3.47	15.18	0.42	1.84	0.38	1.65	0.54	2.36	21987
Caterpillar 3516J TA Natural Gas Compressor Engine	ENG11	ENG11	1.90	8.33	1.01	4.42	1.29	5.63	0.13	0.55	0.11	0.49	0.32	1.39	6695
Caterpillar 3516J TA Natural Gas Compressor Engine	ENG12	ENG12	1.90	8.33	1.01	4.42	1.29	5.63	0.13	0.55	0.11	0.49	0.32	1.39	6695
Fuel Line Heater (0.75 MMBtu/hr)	HTR1	HTR1	0.11	0.50	0.10	0.42	0.01	0.03	0.01	0.04	0.01	0.04	0.002	0.01	528
Glycol Regenerator Reboiler (2.0 MMBtu/hr)	RB1	RB1	0.31	1.34	0.26	1.12	0.02	0.07	0.03	0.12	0.02	0.10	0.006	0.03	1407
Glycol Regenerator Reboiler (2.0 MMBtu/hr)	RB2	RB1	0.31	1.34	0.26	1.12	0.02	0.07	0.03	0.12	0.02	0.10	0.006	0.03	1407
Glycol Regenerator Reboiler (2.0 MMBtu/hr)	RB3	RB1	0.31	1.34	0.26	1.12	0.02	0.07	0.03	0.12	0.02	0.10	0.006	0.03	1407
Total Flare Pilot/Purge Emissions	FL1-FL2 Pilot	FL1-FL2 Pilot	0.67	2.93	1.33	5.84	0.94	4.13	0.01	0.03	0.03	0.13	0.01	0.04	3489
Total Flare Normal Operations	FL1-FL2 Norm	FL1-FL2 Norm	1.85	7.72	3.69	15.41	11.53	25.60	0.01	0.04	0.03	0.15	0.48	1.10	8057
Total Flare SSM	FL1-FL2 SSM	FL1-FL2 SSM	541.65	8.10	1081.35	16.17	992.97	18.36	4.91	0.08	22.25	0.31	27.52	0.55	9993
BTEX Vapor Combustor	VC1	VC1	0.41	1.80	0.82	3.59	2.61	11.43	0.29	1.26	0.010	0.04	0.32	1.38	2461
TEG Dehydrator with Condenser	DEHY1	VC1	Emissions Represented at VC1												
TEG Dehydrator with Condenser	DEHY2	VC1	Emissions Represented at VC1												
TEG Dehydrator with Condenser	DEHY3	VC1	Emissions Represented at VC1												
Skim Tank	SKT1	FL1-FL2	Emissions Represented at FL1-FL2												
Skim Tank (Backup)	SKT2	FL1-FL2	Emissions Represented at FL1-FL2												
Condensate Tank	OT1	FL1-FL2	Emissions Represented at FL1-FL2												
Condensate Tank	OT2	FL1-FL2	Emissions Represented at FL1-FL2												

XTO ENERGY, INC.  
 BULLDOG COMPRESSOR STATION  
 FACILITY EMISSIONS SUMMARY

EMISSIONS SUMMARY TABLE

EMISSION SOURCE DESCRIPTION	FACILITY IDENTIFICATION NUMBER	STACK NUMBER	NOx		CO		VOC (INCLUDES HAPs)		SO <sub>2</sub>		PM <sub>10 &amp; 2.5</sub>		HAPs		CO <sub>2e</sub>
			lb/hr	TPY	lb/hr	TPY	lb/hr	TPY	lb/hr	TPY	lb/hr	TPY	lb/hr	TPY	TPY
Condensate Tank	OT3	FL1-FL2	Emissions Represented at FL1-FL2												
Condensate Tank	OT4	FL1-FL2	Emissions Represented at FL1-FL2												
Produced Water Tank	WT1	FL1-FL2	Emissions Represented at FL1-FL2												
Produced Water Tank	WT2	FL1-FL2	Emissions Represented at FL1-FL2												
Low Pressure Separator	LPS	FL1-FL2	Emissions Represented at FL1-FL2												
Condensate Truck Loading	LOAD	N/A	-	-	-	-	65.70	11.14	-	-	-	-	0.03	0.01	-
Fugitive Emissions	FUG	N/A	-	-	-	-	4.89	21.43	-	-	-	-	0.38	1.64	-
SSM Activities	SSM	N/A	-	-	-	-	-	10.00	-	-	-	-	-	-	-
ROAD EMISSIONS	ROAD	ROAD	-	-	-	-	-	-	-	-	0.15	0.02	-	-	-
Malfunction Emissions	MALFUNCTION	MALFUNCTION	-	-	-	-	-	10.00	-	-	-	-	-	-	-
<b>TOTAL FACILITY WIDE EMISSIONS</b>			NOx		CO		VOC (INCLUDES HAPs)		SO <sub>2</sub>		PM <sub>10 &amp; 2.5</sub>		HAPs		CO <sub>2e</sub>
			lb/hr	TPY	lb/hr	TPY	lb/hr	TPY	lb/hr	TPY	lb/hr	TPY	lb/hr	TPY	TPY
			586.62	204.66	1129.54	226.49	1112.48	260.24	9.34	19.49	26.16	16.80	34.24	28.84	240,024

**XTO ENERGY, INC.**  
**BULLDOG COMPRESSOR STATION**  
**Methodology for Burner Calculations**

**Burner Emission Calculations**

**AP 42 Emission Factors: Tables 1.4-1, 1.4-2, & 1.4-3**

$$\text{Emission Rate}_x (\text{lb/hr}) = \text{Burner Rating (MMBTU/hr)} * \text{EF}_x (\text{lb/MMSCF}) / 1020 (\text{Btu/scf}) * \text{Heating Value of Fuel Gas (BTU/SCF)} / 1020 (\text{Btu/scf}) + 25\%$$

$$\text{Annual Emission Rate}_x (\text{TPY}) = \text{Emission Rate (lb/hr)} * 8760 (\text{hour/year}) / 2000 (\text{lb/ton})$$

**Mass Balance - SO<sub>2</sub> & H<sub>2</sub>S Calculations**

$$\text{H}_2\text{S Mass Flow Rate (lb/hr)} = P * V / 10.73 / T * \text{MW}_{\text{GAS}} * \text{H}_2\text{S}_{\text{WEIGHT \%}} * (1 - \text{DRE})$$

P = Pressure (psia), V = Fuel Consumed in a hour (ft<sup>3</sup>/hr), 10.73 = Ideal Gas Constant, T = Temperature (°R)

$$\text{Uncontrolled H}_2\text{S Mass Flow Rate (lb/hr)} = P * V / 10.73 / T * \text{MW}_{\text{GAS}} * \text{H}_2\text{S}_{\text{WEIGHT \%}}$$

$$\text{SO}_2 \text{ Emission Rate (lb/hr)} = \text{Uncontrolled H}_2\text{S Mass Rate (lb/hr)} * \text{SO}_2 \text{ Conversion Efficiency} * (\text{MW of SO}_2 (\text{lb/lb-mol}) / \text{MW of H}_2\text{S (lb/lb-mol)})$$

$$\text{Annual Emission Rate (TPY)} = \text{Emission Rate (lb/hr)} * 8760 (\text{hour/year}) / 2000 (\text{lb/ton})$$

MW<sub>GAS</sub> = Molecular Weight of the Gas, H<sub>2</sub>S<sub>WEIGHT%</sub> = Weight Percent of the H<sub>2</sub>S in the Fuel Gas, DRE = Burner Combustion Efficiency of H<sub>2</sub>S

**XTO ENERGY INC.**  
**WILDCAT COMPRESSOR STATION**  
**Methodology for Engine Calculations**

**Engine Emission Calculations**

**Manufacturer's Data or NSPS Subpart JJJJ Limit Calculations**

$$\text{Emission Rate}_x \text{ (lb/hr)} = \text{Emission Factor}_x \text{ (g/hp-hr)} * \text{Rated hp} / 453.6 \text{ (g/lb)}$$

$$\text{Annual Emission Rate}_x \text{ (TPY)} = \text{Emission Rate (lb/hr)} * 8760 \text{ (hour/year)} / 2000 \text{ (lb/ton)}$$

**AP 42 Emission Factors**

$$\text{Emission Rate}_x \text{ (lb/hr)} = \text{Fuel Consumption (MMBTU/hp-hr)} * \text{EF}_x \text{ (lb/MMBTU)} * \text{Rated hp}$$

$$\text{Annual Emission Rate}_x \text{ (TPY)} = \text{Emission Rate}_x \text{ (lb/hr)} * 8760 \text{ (hour/year)} / 2000 \text{ (lb/ton)}$$



**XTO ENERGY INC.**  
**WILDCAT COMPRESSOR STATION**  
**Methodology for Flare Calculations**

**Flare Calculations**

**VOC Flare Calculations - Uses the Ideal Gas Law for Mixtures**

The mass flow rate of VOCs to the flare were modeled using Promax. The mass rate was then reduced by the destruction efficiency of the flare (98%).

**NOx & CO Calculations - TCEQ Emission Factors Used**

$$\text{NOx (lb/day)} = \text{Heating Value (BTU/ft}^3) * \text{EF (lb/MMBTU)} * \text{V (ft}^3/\text{Day)} / 10^6 \text{ (BTU/MMBTU)}$$

$$\text{CO (lb/day)} = \text{Heating Value (BTU/ft}^3) * \text{EF (lb/MMBTU)} * \text{V (ft}^3/\text{Day)} / 10^6 \text{ (BTU/MMBTU)}$$

COEF = 0.5496 or 0.2755, NOxEF = 0.138, EF = Emission Factor, V = Volume of Gas in a Day

**SO<sub>2</sub> & H<sub>2</sub>S Calculations - Mass Balance**

$$\text{H}_2\text{S Mass Flow Rate (lb/hr)} = P * V / 10.73 / T * \text{MW}_{\text{GAS}} * \text{H}_2\text{S}_{\text{WEIGHT \%}} * (1 - \text{DRE})$$

P = Pressure (psia), V = Fuel Consumed in a hour (ft<sup>3</sup>/hr), 10.73 = Ideal Gas Constant, T = Temperature (°R)

$$\text{Uncontrolled H}_2\text{S Mass Flow Rate (lb/hr)} = P * V / 10.73 / T * \text{MW}_{\text{GAS}} * \text{H}_2\text{S}_{\text{WEIGHT \%}}$$

$$\text{SO}_2 \text{ Emission Rate (lb/hr)} = \text{Uncontrolled H}_2\text{S Mass Rate (lb/hr)} * \text{SO}_2 \text{ Conversion Efficiency} * (\text{MW of SO}_2 \text{ (lb/lb-mol)} / \text{MW of H}_2\text{S (lb/lb-mol)})$$

$$\text{Annual Emission Rate (TPY)} = \text{Emission Rate (lb/hr)} * 8760 \text{ (hour/year)} / 2000 \text{ (lb/ton)}$$

MW<sub>GAS</sub> = Molecular Weight of the Gas, H<sub>2</sub>S<sub>WEIGHT%</sub> = Weight Percent of the H<sub>2</sub>S in Gas Stream, DRE = Flare Destruction Efficiency of H<sub>2</sub>S

**XTO ENERGY, INC.**  
**BULLDOG COMPRESSOR STATION**  
**COMPRESSOR ENGINES**

**Uncontrolled Emissions Calculations**

Source ID	Unit Description	Annual Hours	Rated HP	MMbtu/hp-hr <sup>1</sup> (HHV)	Manufacturer's Data				AP-42 Factors			lb/hr <sup>5</sup>							tpy <sup>5</sup>						
					g/hp-hr <sup>2</sup>				lb/MMBtu <sup>3,4</sup>			NOx	CO	VOC	HCHO	SO <sub>2</sub>	PM <sub>10 &amp; 2.5</sub>	Acetaldehyde	NOx	CO	VOC	HCHO	SO <sub>2</sub>	PM <sub>10 &amp; 2.5</sub>	Acetaldehyde
					NOx	CO	VOC	HCHO	SO <sub>2</sub>	PM <sub>10 &amp; 2.5</sub>	Acetaldehyde														
ENG1	Caterpillar G3616 Natural Gas Compressor Engine	8760	5000	0.007476	0.30	3.06	0.87	0.15	0.01125	0.01006	0.00836	4.13	33.73	9.90	1.65	0.42	0.38	0.31	18.11	147.74	43.37	7.24	1.84	1.65	1.37
ENG2	Caterpillar G3616 Natural Gas Compressor Engine	8760	5000	0.007476	0.30	3.06	0.87	0.15	0.01125	0.01006	0.00836	4.13	33.73	9.90	1.65	0.42	0.38	0.31	18.11	147.74	43.37	7.24	1.84	1.65	1.37
ENG3	Caterpillar G3616 Natural Gas Compressor Engine	8760	5000	0.007476	0.30	3.06	0.87	0.15	0.01125	0.01006	0.00836	4.13	33.73	9.90	1.65	0.42	0.38	0.31	18.11	147.74	43.37	7.24	1.84	1.65	1.37
ENG4	Caterpillar G3616 Natural Gas Compressor Engine	8760	5000	0.007476	0.30	3.06	0.87	0.15	0.01125	0.01006	0.00836	4.13	33.73	9.90	1.65	0.42	0.38	0.31	18.11	147.74	43.37	7.24	1.84	1.65	1.37
ENG5	Caterpillar G3616 Natural Gas Compressor Engine	8760	5000	0.007476	0.30	3.06	0.87	0.15	0.01125	0.01006	0.00836	4.13	33.73	9.90	1.65	0.42	0.38	0.31	18.11	147.74	43.37	7.24	1.84	1.65	1.37
ENG6	Caterpillar G3616 Natural Gas Compressor Engine	8760	5000	0.007476	0.30	3.06	0.87	0.15	0.01125	0.01006	0.00836	4.13	33.73	9.90	1.65	0.42	0.38	0.31	18.11	147.74	43.37	7.24	1.84	1.65	1.37
ENG7	Caterpillar G3616 Natural Gas Compressor Engine	8760	5000	0.007476	0.30	3.06	0.87	0.15	0.01125	0.01006	0.00836	4.13	33.73	9.90	1.65	0.42	0.38	0.31	18.11	147.74	43.37	7.24	1.84	1.65	1.37
ENG8	Caterpillar G3616 Natural Gas Compressor Engine	8760	5000	0.007476	0.30	3.06	0.87	0.15	0.01125	0.01006	0.00836	4.13	33.73	9.90	1.65	0.42	0.38	0.31	18.11	147.74	43.37	7.24	1.84	1.65	1.37
ENG9	Caterpillar G3616 Natural Gas Compressor Engine	8760	5000	0.007476	0.30	3.06	0.87	0.15	0.01125	0.01006	0.00836	4.13	33.73	9.90	1.65	0.42	0.38	0.31	18.11	147.74	43.37	7.24	1.84	1.65	1.37
ENG11	Caterpillar 3516J TA Natural Gas Compressor Engine	8760	1380	0.008095	0.50	2.55	0.91	0.36	0.01125	0.01006	0.00836	1.90	7.76	3.96	1.10	0.13	0.11	0.09	8.33	33.98	17.33	4.80	0.55	0.49	0.41
ENG12	Caterpillar 3516J TA Natural Gas Compressor Engine	8760	1380	0.008095	0.50	2.55	0.91	0.36	0.01125	0.01006	0.00836	1.90	7.76	3.96	1.10	0.13	0.11	0.09	8.33	33.98	17.33	4.80	0.55	0.49	0.41

<sup>1</sup>HHV is based on the Fuel Consumption Rate @ 75% Load from the Gas Engine Rating Pro Report  
<sup>2</sup>The VOC emission factor (g/hp-hr) includes HCHO. Emission factors based on Gas Engine Rating Pro Report @ 100% Load.  
<sup>3</sup>SO<sub>2</sub> Emissions were calculated using the emission factor from Table 3.2-2  
<sup>4</sup>PM Emission Factor = 7.71E-05 lb/MMBTU + 7.71E-05 lb/MMBTU + 9.91E-03 lb/MMBTU = 0.01006 lb/MMBTU  
<sup>5</sup>25% safety factor was added to NOx on all engines. 25% safety factor was added to VOC on 3516. VOC lb/hr rates include acetaldehyde emissions.

Total Emissions Per Pollutant (TPY)	NOx	CO	VOC	HCHO	SO <sub>2</sub>	PM <sub>10 &amp; 2.5</sub>	Acetaldehyde
	179.60	1397.60	425.02	74.77	17.69	15.81	13.14

**XTO ENERGY, INC.**  
**BULLDOG COMPRESSOR STATION**  
**COMPRESSOR ENGINES**

**Controlled Emissions Calculations**

Source ID	Unit Description	Annual Hours	Rated HP	MMbtu/hp-hr <sup>1</sup> (HHV)	Control Efficiency (%)			Manufacturer's Data (w/ control) g/hp-hr <sup>2</sup>				AP-42 Factors lb/MMBtu <sup>3</sup>			lb/hr <sup>4</sup>							tpy						
					CO	VOC	HCOH	NOx	CO	VOC <sup>2</sup>	HCHO	SO <sub>2</sub>	PM <sub>10 &amp; 2.5</sub>	Acetaldehyde	NOx	CO	VOC	HCHO	SO <sub>2</sub>	PM <sub>10 &amp; 2.5</sub>	Acetaldehyde	NOx	CO	VOC	HCHO	SO <sub>2</sub>	PM <sub>10 &amp; 2.5</sub>	Acetaldehyde
ENG1	Caterpillar G3616 Natural Gas Compressor Engine	8760	5000	0.007476	87.0	65.0	74.0	0.30	0.40	0.30	0.04	0.0113	0.01006	0.00836	4.13	4.38	3.47	0.43	0.42	0.38	0.11	18.11	19.21	15.18	1.88	1.84	1.65	0.48
ENG2	Caterpillar G3616 Natural Gas Compressor Engine	8760	5000	0.007476	87.0	65.0	74.0	0.30	0.40	0.30	0.04	0.0113	0.01006	0.00836	4.13	4.38	3.47	0.43	0.42	0.38	0.11	18.11	19.21	15.18	1.88	1.84	1.65	0.48
ENG3	Caterpillar G3616 Natural Gas Compressor Engine	8760	5000	0.007476	87.0	65.0	74.0	0.30	0.40	0.30	0.04	0.0113	0.01006	0.00836	4.13	4.38	3.47	0.43	0.42	0.38	0.11	18.11	19.21	15.18	1.88	1.84	1.65	0.48
ENG4	Caterpillar G3616 Natural Gas Compressor Engine	8760	5000	0.007476	87.0	65.0	74.0	0.30	0.40	0.30	0.04	0.0113	0.01006	0.00836	4.13	4.38	3.47	0.43	0.42	0.38	0.11	18.11	19.21	15.18	1.88	1.84	1.65	0.48
ENG5	Caterpillar G3616 Natural Gas Compressor Engine	8760	5000	0.007476	87.0	65.0	74.0	0.30	0.40	0.30	0.04	0.0113	0.01006	0.00836	4.13	4.38	3.47	0.43	0.42	0.38	0.11	18.11	19.21	15.18	1.88	1.84	1.65	0.48
ENG6	Caterpillar G3616 Natural Gas Compressor Engine	8760	5000	0.007476	87.0	65.0	74.0	0.30	0.40	0.30	0.04	0.0113	0.01006	0.00836	4.13	4.38	3.47	0.43	0.42	0.38	0.11	18.11	19.21	15.18	1.88	1.84	1.65	0.48
ENG7	Caterpillar G3616 Natural Gas Compressor Engine	8760	5000	0.007476	87.0	65.0	74.0	0.30	0.40	0.30	0.04	0.0113	0.01006	0.00836	4.13	4.38	3.47	0.43	0.42	0.38	0.11	18.11	19.21	15.18	1.88	1.84	1.65	0.48
ENG8	Caterpillar G3616 Natural Gas Compressor Engine	8760	5000	0.007476	87.0	65.0	74.0	0.30	0.40	0.30	0.04	0.0113	0.01006	0.00836	4.13	4.38	3.47	0.43	0.42	0.38	0.11	18.11	19.21	15.18	1.88	1.84	1.65	0.48
ENG9	Caterpillar G3616 Natural Gas Compressor Engine	8760	5000	0.007476	87.0	65.0	74.0	0.30	0.40	0.30	0.04	0.0113	0.01006	0.00836	4.13	4.38	3.47	0.43	0.42	0.38	0.11	18.11	19.21	15.18	1.88	1.84	1.65	0.48
ENG11	Caterpillar 3516J TA Natural Gas Compressor Engine	8760	1380	0.008095	87.0	65.0	74.0	0.50	0.33	0.32	0.09	0.0113	0.01006	0.00836	1.90	1.01	1.29	0.28	0.13	0.11	0.03	8.33	4.42	5.63	1.25	0.55	0.49	0.14
ENG12	Caterpillar 3516J TA Natural Gas Compressor Engine	8760	1380	0.008095	87.0	65.0	74.0	0.50	0.33	0.32	0.09	0.0113	0.01006	0.00836	1.90	1.01	1.29	0.28	0.13	0.11	0.03	8.33	4.42	5.63	1.25	0.55	0.49	0.14

<sup>1</sup>HHV is conservatively based on the Fuel Consumption Rate @ 75% Load from the Gas Engine Rating Pro Report

<sup>2</sup>The VOC emission factor (g/hp-hr) includes HCHO. Emission factors based on Gas Engine Rating Pro Report.

<sup>3</sup>SO<sub>2</sub> Emissions were calculated using the emission factor from Table 3.2-2

<sup>4</sup>PM Emission Factor = 7.71E-05 lb/MMBTU + 7.71E-05 lb/MMBTU + 9.91E-03 lb/MMBTU = 0.01006 lb/MMBTU

<sup>5</sup>25% safety factor was added to NOx on all engines. 25% safety factor was added to VOC on 3516. VOC lb/hr rates include acetaldehyde emissions.

Total Emissions Per Pollutant (TPY)	NOx	CO	VOC	HCHO	SO <sub>2</sub>	PM <sub>10 &amp; 2.5</sub>	Acetaldehyde
	179.60	181.69	147.89	19.44	17.69	15.81	4.60

**XTO ENERGY, INC.**  
**BULLDOG COMPRESSOR STATION**  
**COMPRESSOR ENGINES**

**Greenhouse Gas Emissions Calculations**

Source ID	Unit Description	Annual Hours	Rated HP	MMbtu/hp-hr <sup>1</sup> (HHV)	Engine Data			40 CFR 98 Factors <sup>2</sup>					tpy							
					g/hp-hr			lb/MMBtu			lb/hr					tpy				
					CO2	CH <sub>4</sub>	N <sub>2</sub> O	CO2	CH <sub>4</sub>	N <sub>2</sub> O	CO2	CH <sub>4</sub>	N <sub>2</sub> O	CH <sub>4</sub> as CO2e	N <sub>2</sub> O as CO2e	CO2	CH <sub>4</sub>	N <sub>2</sub> O	CH <sub>4</sub> as CO2e	N <sub>2</sub> O as CO2e
ENG1	Caterpillar G3616 Natural Gas Compressor Engine	8760	5000	0.007476	455	0.002205	0.000221	5015.43	0.0824	0.0082	2.06	2.46	21967.59	0.36	0.04	9.03	10.76	21987.38		
ENG2	Caterpillar G3616 Natural Gas Compressor Engine	8760	5000	0.007476	455	0.002205	0.000221	5015.43	0.0824	0.0082	2.06	2.46	21967.59	0.36	0.04	9.03	10.76	21987.38		
ENG3	Caterpillar G3616 Natural Gas Compressor Engine	8760	5000	0.007476	455	0.002205	0.000221	5015.43	0.0824	0.0082	2.06	2.46	21967.59	0.36	0.04	9.03	10.76	21987.38		
ENG4	Caterpillar G3616 Natural Gas Compressor Engine	8760	5000	0.007476	455	0.002205	0.000221	5015.43	0.0824	0.0082	2.06	2.46	21967.59	0.36	0.04	9.03	10.76	21987.38		
ENG5	Caterpillar G3616 Natural Gas Compressor Engine	8760	5000	0.007476	455	0.002205	0.000221	5015.43	0.0824	0.0082	2.06	2.46	21967.59	0.36	0.04	9.03	10.76	21987.38		
ENG6	Caterpillar G3616 Natural Gas Compressor Engine	8760	5000	0.007476	455	0.002205	0.000221	5015.43	0.0824	0.0082	2.06	2.46	21967.59	0.36	0.04	9.03	10.76	21987.38		
ENG7	Caterpillar G3616 Natural Gas Compressor Engine	8760	5000	0.007476	455	0.002205	0.000221	5015.43	0.0824	0.0082	2.06	2.46	21967.59	0.36	0.04	9.03	10.76	21987.38		
ENG8	Caterpillar G3616 Natural Gas Compressor Engine	8760	5000	0.007476	455	0.002205	0.000221	5015.43	0.0824	0.0082	2.06	2.46	21967.59	0.36	0.04	9.03	10.76	21987.38		
ENG9	Caterpillar G3616 Natural Gas Compressor Engine	8760	5000	0.007476	455	0.002205	0.000221	5015.43	0.0824	0.0082	2.06	2.46	21967.59	0.36	0.04	9.03	10.76	21987.38		
ENG11	Caterpillar 3516J TA Natural Gas Compressor Engine	8760	1380	0.008095	502	0.002205	0.000221	1527.25	0.0246	0.0025	0.62	0.73	6689.35	0.11	0.01	2.70	3.22	6695.26		
ENG12	Caterpillar 3516J TA Natural Gas Compressor Engine	8760	1380	0.008095	502	0.002205	0.000221	1527.25	0.0246	0.0025	0.62	0.73	6689.35	0.11	0.01	2.70	3.22	6695.26		

<sup>1</sup>HHV is based on the Fuel Consumption Rate @ 75% Load from the Gas Engine Rating Pro Report  
<sup>2</sup>Warming potential for CH<sub>4</sub> is 25. N<sub>2</sub>O is 298.

Total Emissions (TPY)	Total CO2e
	<b>211276.91</b>

**XTO ENERGY, INC.**  
**BULLDOG COMPRESSOR STATION**  
**HEATERS - BURNER CALCULATIONS & EXHAUST STACK FLOW & FUEL CONSUMPTION RATES**

**CRITERIA & REGULATED POLLUTANTS EMISSIONS**

Source ID	Promax Fuel Gas Stream	Fuel Gas HHV (BTU/SCF)	Operating Hours	Burner Rating (MMBTU/Hr)	AP-42 Factors <sup>1</sup> lb/MMBtu					lb/hr <sup>2</sup>					tpy <sup>2</sup>				
					NOx	CO	VOC	SO <sub>2</sub>	PM <sub>10 &amp; 2.5</sub>	NOx	CO	VOC	SO <sub>2</sub>	PM <sub>10 &amp; 2.5</sub>	NOx	CO	VOC	SO <sub>2</sub>	PM <sub>10 &amp; 2.5</sub>
					HTR1	3. Fuel Gas	1,269	8,760	0.75	0.10	0.08	0.01	0.01	0.01	0.11	0.10	0.01	0.01	0.01
RB1	3. Fuel Gas	1,269	8,760	2.00	0.10	0.08	0.01	0.01	0.01	0.31	0.26	0.02	0.03	0.02	1.34	1.12	0.07	0.12	0.10
RB2	3. Fuel Gas	1,269	8,760	2.00	0.10	0.08	0.01	0.01	0.01	0.31	0.26	0.02	0.03	0.02	1.34	1.12	0.07	0.12	0.10
RB3	3. Fuel Gas	1,269	8,760	2.00	0.10	0.08	0.01	0.01	0.01	0.31	0.26	0.02	0.03	0.02	1.34	1.12	0.07	0.12	0.10

<sup>1</sup>Source: Emission factors from AP-42, Chapter 1, Tables 1.4-1, 1.4-2 and 1.4-3, converted from lb/MMscf to lb/MMbtu by dividing by 1,020 Btu/scf (per AP-42, Chapter 1 guidance).  
SO<sub>2</sub> - 5 gr/100 scf

<sup>2</sup>Burners - 25% Safety Factor

Total (tpy)	NOx	CO	VOC	SO <sub>2</sub>	PM <sub>10 &amp; 2.5</sub>
	<b>4.51</b>	<b>3.79</b>	<b>0.25</b>	<b>0.39</b>	<b>0.34</b>

**XTO ENERGY, INC.**  
**BULLDOG COMPRESSOR STATION**  
**HEATERS - BURNER CALCULATIONS & EXHAUST STACK FLOW & FUEL CONSUMPTION RATES**

**HAZARDOUS AIR POLLUTANTS (HAP) EMISSIONS**

Source ID	Promax Stream	Fuel Gas (BTU/SCF)	Operating Hours	Burner Rating (MMBTU/Hr)	AP-42 Factors <sup>1</sup>					lb/hr <sup>2</sup>					tpy <sup>2</sup>				
					lb/MMBtu					Benzene	Toluene	N-Hexane	HCHO	Dichloro benzene	Benzene	Toluene	N-Hexane	HCHO	Dichloro benzene
					Benzene	Toluene	N-Hexane	HCHO	Dichloro benzene										
HTR1	3. Fuel Gas	1,269	8760	0.75	2.1E-06	3.3E-06	1.8E-03	7.4E-05	1.2E-06	<0.001	<0.001	0.00	<0.001	<0.001	<0.001	<0.001	0.01	<0.001	<0.001
RB1	3. Fuel Gas	1,269	8760	2.00	2.1E-06	3.3E-06	1.8E-03	7.4E-05	1.2E-06	<0.001	<0.001	0.01	<0.001	<0.001	<0.001	<0.001	0.02	0.00	<0.001
RB2	3. Fuel Gas	1,269	8760	2.00	2.1E-06	3.3E-06	1.8E-03	7.4E-05	1.2E-06	<0.001	<0.001	0.01	<0.001	<0.001	<0.001	<0.001	0.02	0.00	<0.001
RB3	3. Fuel Gas	1,269	8760	2.00	2.1E-06	3.3E-06	1.8E-03	7.4E-05	1.2E-06	<0.001	<0.001	0.01	<0.001	<0.001	<0.001	<0.001	0.02	0.00	<0.001

<sup>1</sup>Source: Emission factors from AP-42, Chapter 1, Tables 1.4-1, 1.4-2 and 1.4-3, converted from lb/MMscf to lb/MMbtu by dividing by 1,020 Btu/scf (per AP-42, Chapter 1 guidance).  
SO2 - 5 gr/100 scf

<sup>2</sup>Burners - 25% Safety Factor

Total Individual HAPS (tpy)	Benzene	Toluene	N-Hexane	HCHO	Dichloro benzene
		0.00	0.00	0.08	0.00

<b>Total Combined HAPS (tpy)</b>	<b>0.08</b>
----------------------------------	-------------

**XTO ENERGY, INC.**  
**BULLDOG COMPRESSOR STATION**  
**HEATERS - BURNER CALCULATIONS & EXHAUST STACK FLOW & FUEL CONSUMPTION RATES**

**Exhaust Stack and Fuel Consumption Data**

Source	HTR1	RB1	RB2	RB3		
Burner Rating (btu/hr)	750000	2000000	2000000	2000000		
Gross Heating Value (btu/scf)	1269.3	1269.3	1269.3	1269.3		
3" eclipse air mixer: (Air/Gas Ratio) <sup>1</sup>	5/1	5/1	5/1	5/1		
Stack Temperature (°F)	1000	1000	1000	1000		
Stack Diameter (ft)	1	1.5	1.5	1.5		
Stack Height (ft)	20	20	20	20		
Fuel Consumption (scf/hr)	591	1576	1576	1576		
Fuel Consumption (scf/day)	14181	37816	37816	37816		
Fuel Consumption (mmscf/year)	5	14	14	14		
Air Injection Rate (scf/hr)	5909	15757	15757	15757		
Total exhaust flow rate @ STP (scf/hr)	6500	17332	17332	17332		
Total exhaust flow rate @ STP (scf/sec)	2	5	5	5		
Total exhaust flow rate @ 1000 °F (acf/hr)	18249	48664	48664	48664		
Total exhaust flow rate @ 1000 °F (acf/sec)	5.07	14	14	14		
Exhaust Stack Exit Velocity @ STP (ft/sec)	2.30	3	3	3		
Exhaust Stack Exit Velocity @ 1000 °F (ft/sec)	6.45	8	8	8		
Total CH4 (ton/yr) <sup>2</sup>	0.32	0.85	0.85	0.85		
Total N2O (ton/yr) <sup>2</sup>	0.001	0.002	0.002	0.002		
Total CO2 (ton/yr) <sup>2</sup>	519	1385	1385	1385		
Total CO2e (ton/yr) <sup>2</sup>	527.51	1407	1407	1407		

Promax Stream Name	3. Fuel Gas
Component	Mass Frac
Triethylene Glycol	0.00
Water	0.00
Hydrogen Sulfide	0.00
Carbon Dioxide	0.00
Nitrogen	0.01
Methane	0.58
Ethane	0.18
Propane	0.13
Isobutane	0.02
n-Butane	0.05
Isopentane	0.01
n-Pentane	0.01
i-C6	0.01
i-C7	0.00
Octane	0.00
Nonane	0.00
Benzene	0.00
Toluene	0.00
Ethylbenzene	0.00
o-Xylene	0.00
n-Hexane	0.00
2,2,4-Trimethylpentane	0.00
Decanes Plus	0.00
Decanes Plus Sat	0.00

<sup>1</sup> Air/Gas Ratio is based on the Manufacturer's Data of XTO's typical burner installations

<sup>2</sup> GHG emissions source is 40 CFR § 98.233 (n), 40 CFR § 98.233(v) for CH4 and CO2 mass emissions, 40 CFR § 98.233(z) for N2O mass emissions,

**XTO ENERGY, INC.**  
**BULLDOG COMPRESSOR STATION**  
**STORAGE TANK EMISSIONS SUMMARY**

**VOC EMISSIONS SUMMARY**

Unit Number	Source Description	Material Type (Oil/Produced Water)	Number of Tanks in Category	Controlled by Unit #	Control Efficiency (%)	Promax Stream Liquid Material	Material Throughput (bbls/day)	Uncontrolled Working & Breathing Losses				Uncontrolled Flash Losses				Uncontrolled Total Emissions		Controlled Total Emissions	
								Promax Stream (Hrly)	Promax Stream (Annual)	Lb/hr	TPY	Promax Stream (Hrly)	Promax Stream (Annual)	Lb/hr	TPY	Lb/hr	TPY	Lb/hr	TPY
SKT1	Skim Tank	Produced Water	2	FL1-FL2	98	14. Skim Tank Inlet	173.54	8. Skim Tank W&B	8. Skim Tank W&B	3.62	15.85	6. Skim Tank Flash Gas	6. Skim Tank Flash Gas	1.25	5.47	4.87	21.32	0.10	0.43
SKT2	Skim Tank (Backup)	Produced Water	2	FL1-FL2	98	14. Skim Tank Inlet	173.54	8. Skim Tank W&B	8. Skim Tank W&B	3.62	15.85	6. Skim Tank Flash Gas	6. Skim Tank Flash Gas	1.25	5.47	4.87	21.32	0.10	0.43
OT1	Condensate Tank	Condensate	4	FL1-FL2	98	11. Condensate Sales Liquid	203.55	10. Condensate Tank W&B	10. Condensate Tank W&B	4.55	19.91	22. Condensate Flash Losses Hrly	7. Condensate Tank Flash Gas	133.69	275.73	138.24	295.64	2.76	5.91
OT2	Condensate Tank	Condensate	4	FL1-FL2	98	11. Condensate Sales Liquid	203.55	10. Condensate Tank W&B	10. Condensate Tank W&B	4.55	19.91	22. Condensate Flash Losses Hrly	7. Condensate Tank Flash Gas	133.69	275.73	138.24	295.64	2.76	5.91
OT3	Condensate Tank	Condensate	4	FL1-FL2	98	11. Condensate Sales Liquid	203.55	10. Condensate Tank W&B	10. Condensate Tank W&B	4.55	19.91	22. Condensate Flash Losses Hrly	7. Condensate Tank Flash Gas	133.69	275.73	138.24	295.64	2.76	5.91
OT4	Condensate Tank	Condensate	4	FL1-FL2	98	11. Condensate Sales Liquid	203.55	10. Condensate Tank W&B	10. Condensate Tank W&B	4.55	19.91	22. Condensate Flash Losses Hrly	7. Condensate Tank Flash Gas	133.69	275.73	138.24	295.64	2.76	5.91
WT1	Produced Water Tank	Produced Water	2	FL1-FL2	98	12. Produced Water Liquid	170.55	9. Water Tank W&B	9. Water Tank W&B	0.11	0.47	5. Water Tank Flash Gas	5. Water Tank Flash Gas	0.00	0.00	0.11	0.47	0.00	0.01
WT2	Produced Water Tank	Produced Water	2	FL1-FL2	98	12. Produced Water Liquid	170.55	9. Water Tank W&B	9. Water Tank W&B	0.11	0.47	5. Water Tank Flash Gas	5. Water Tank Flash Gas	0.00	0.00	0.11	0.47	0.00	0.01
<b>Storage Tank Emissions</b>										25.64	112.28			537.26	1113.85	562.90	1226.13	11.26	24.52



**XTO ENERGY, INC.**  
**BULLDOG COMPRESSOR STATION**  
**OIL TRUCK LOADING LOSSES - UNCONTROLLED**

**Truck Loading Losses Calculations**

<b>Promax Stream Production</b>	11. Condensate Sales Liquid	
<b>Promax Stream Emissions</b>	10. Condensate Tank W&B	
<b>Controlled/Uncontrolled</b>	UNCONTROLLED	
<b>Operating Schedule<sup>c</sup></b>	<b>100</b>	<b>Day / Year</b>
<b>Condensate Production</b>	<b>814</b>	<b>bbls / Day</b>

**Promax Report Results**

**LL= 12.46 \* SPM/T \* (1-EFF/100)**

Saturation Factor (S) =	0.6
Average True Vapor Pressure of liquid loaded (P) <sup>a</sup> =	9.14
Max True Vapor Pressure of liquid loaded (P) <sup>a</sup> =	10.63
Average Temperature of bulk liquid loaded in Rankin (T) <sup>a</sup> =	529.10
Max Temperature of bulk liquid loaded in Rankin (T) <sup>a</sup> =	538.27
Molecular Weight (M) <sup>a</sup> =	54.80
Control Efficiency * Collection Efficiency (EFF)=	0
Hydrocarbon Content (%wt) <sup>a</sup> =	1.00
VOC Content (wt%) <sup>a</sup> =	0.92
HAP Content (wt%) <sup>a</sup> =	0.04
Average Uncontrolled LL (lb Total HC / bbl Throughput) <sup>b</sup> =	0.2972
Average Uncontrolled LL (lb VOC / bbl Throughput) <sup>b</sup> =	0.2736
Max Uncontrolled LL (lb Total HC / bbl Throughput) <sup>b</sup> =	0.3398
Max Uncontrolled LL (lb VOC / bbl Throughput) <sup>b</sup> =	0.3129
Estimated Throughput (bbls/Year) =	81420
Truck Loading Rate (bbls/hour) =	210
Estimated # of Loads (Approximately 1 hr/Load) =	388

<b>Total Hydrocarbon Emissions</b>	lb/hr	TPY
	71.36	12.10
<b>Total VOC Emissions</b>	lb/hr	TPY
	65.70	11.14
<b>Total HAP Emissions</b>	lb/hr	TPY
	0.03	0.01

**XTO ENERGY, INC.**  
**BULLDOG COMPRESSOR STATION**  
**OIL TRUCK LOADING LOSSES - UNCONTROLLED**

Component	Total Speciated Vapors Emitted During Loading		
	Mass Fraction <sup>d</sup>	lb/hr <sup>d</sup>	ton / yr
Triethylene Glycol	0.00	0.00	0.00
Water	0.00	0.00	0.00
Hydrogen Sulfide	0.00	0.00	0.00
Carbon Dioxide	0.00	0.00	0.00
Nitrogen	0.00	0.00	0.00
Methane	0.00	0.17	0.03
Ethane	0.08	5.49	0.93
Propane	0.24	17.42	2.95
Isobutane	0.08	5.87	1.00
n-Butane	0.24	17.45	2.96
Isopentane	0.08	5.99	1.02
n-Pentane	0.10	6.98	1.18
i-C6	0.08	5.93	1.01
i-C7	0.03	2.39	0.40
Octane	0.01	0.62	0.10
Nonane	0.00	0.09	0.01
Benzene	0.00	0.19	0.03
Toluene	0.00	0.16	0.03
Ethylbenzene	0.00	0.00	0.00
o-Xylene	0.00	0.03	0.01
n-Hexane	0.04	2.58	0.44
2,2,4-Trimethylpentane	0.00	0.00	0.00
Decanes Plus	0.00	0.00	0.00
Decanes Plus Sat	0.00	0.00	0.00
Total HC	1.00	71.36	12.10
Total VOC	0.92	65.70	11.14
Total HAP	0.04	2.97	0.50
Heating Value (Btu/scf)	3080.19	3080.19	3080.19
Molecular Weight (lb/lbmol)	54.80	54.80	54.80
SO2 Emissions (lb/hr)	N/A	N/A	N/A
Operating Hours (hr/yr)	N/A	N/A	2400
Mass Flow	N/A	71.36 lb/hr	12.10 ton/yr
Volumetric Flow (scf/hr)	N/A	494.13	83.78
Heat Release (MMBtu/hr)	N/A	1.52	0.26

**Footnotes:**

<sup>a</sup> Values were obtained from Promax.

<sup>b</sup> Loading emissions include total hydrocarbons as calculated using AP-42, Section 5.2.

<sup>c</sup> Condensate tanks are only trucked out when transfer to pipeline is unavailable.

<sup>d</sup> The component speciation was obtained from Promax Stream " and multiplied by the total hydrocarbon emissions. (VOC = 0.00 lb/hr \* 0.00 wt% VOC = 0.00 lb/hr)

<sup>e</sup> Loading emissions are uncontrolled.

**XTO ENERGY INC.**  
**BULLDOG COMPRESSOR STATION**  
**FLARE 1-3 EMISSION SUMMARY**

**Flare Emissions Summary Table**

Stream Source	Stream Source	NOx		CO		Total VOC (Includes Total HAPs)		SO <sub>2</sub>		PM <sub>10 &amp; 2.5</sub>		Total HAPs		CO <sub>2</sub> e	n-Hexane		Benzene	
		lb/hr	TPY	lb/hr	TPY	lb/hr	TPY	lb/hr	TPY	lb/hr	TPY	lb/hr	TPY	TPY	lb/hr	TPY	lb/hr	TPY
FL1-FL2 Pilot	FL1 Pilot/Purge	0.33	1.46	0.67	2.92	0.47	2.07	0.00	0.01	0.01	0.06	0.00	0.02	1744.35	0.00	0.02	0.00	0.00
	FL2 Pilot / Purge	0.33	1.46	0.67	2.92	0.47	2.07	0.00	0.01	0.01	0.06	0.00	0.02	1744.35	0.00	0.02	0.00	0.00
FL1-FL2 Norm	PW Tank Vapors (WT1-2)	0.00	0.00	0.00	0.01	0.00	0.02	0.00	0.00	0.00	0.00	0.00	0.01	5.77	0.00	0.00	0.00	0.00
	Skim Tank Vapors (SKT1-2)	0.03	0.13	0.06	0.26	0.19	0.85	0.00	0.00	0.00	0.00	0.01	0.05	133.28	0.01	0.04	0.00	0.00
	Oil Tank Vapors (OT1-4)	1.76	7.35	3.52	14.68	11.06	23.65	0.01	0.03	0.03	0.14	0.46	1.00	7641.37	0.36	0.81	0.04	0.09
	Low Pressure Separator Vapors Normal Operation	0.06	0.23	0.12	0.46	0.27	1.08	0.00	0.00	0.00	0.01	0.01	0.04	276.51	0.01	0.03	0.00	0.00
FL1-FL2 SSM	Low Pressure Separator Vapors VRU Downtime	2.94	1.29	5.86	2.57	13.70	6.00	0.04	0.02	0.08	0.03	0.47	0.21	1536.18	0.38	0.17	0.05	0.02
	HP Flare Blowdowns	0.17	0.08	0.33	0.17	0.24	0.12	0.00	0.00	0.01	0.00	0.00	0.00	99.40	0.00	0.00	0.00	0.00
	HP Flare Inlet Gas Flaring	538.55	6.73	1075.15	13.44	979.03	12.24	4.87	0.06	22.17	0.28	27.05	0.34	8357.04	23.90	0.30	1.28	0.02
<b>Total</b>	<b>Total Emissions</b>	<b>544.17</b>	<b>18.74</b>	<b>1086.37</b>	<b>37.42</b>	<b>1005.45</b>	<b>48.09</b>	<b>4.93</b>	<b>0.15</b>	<b>22.31</b>	<b>0.59</b>	<b>28.01</b>	<b>1.68</b>	<b>21538.25</b>	<b>24.66</b>	<b>1.38</b>	<b>1.37</b>	<b>0.14</b>
FL1-FL2 Pilot	<b>Total Flare Pilot/Purge Emissions</b>	<b>0.67</b>	<b>2.93</b>	<b>1.33</b>	<b>5.84</b>	<b>0.94</b>	<b>4.13</b>	<b>0.01</b>	<b>0.03</b>	<b>0.03</b>	<b>0.13</b>	<b>0.01</b>	<b>0.04</b>	<b>3488.70</b>	<b>0.01</b>	<b>0.04</b>	<b>0.00</b>	<b>0.00</b>
FL1-FL2 Norm	<b>Total Flare Normal Operations</b>	<b>1.85</b>	<b>7.72</b>	<b>3.69</b>	<b>15.41</b>	<b>11.53</b>	<b>25.60</b>	<b>0.01</b>	<b>0.04</b>	<b>0.03</b>	<b>0.15</b>	<b>0.48</b>	<b>1.10</b>	<b>8056.93</b>	<b>0.38</b>	<b>0.88</b>	<b>0.04</b>	<b>0.11</b>
FL1-FL2 SSM	<b>Total Flare SSM</b>	<b>541.65</b>	<b>8.10</b>	<b>1081.35</b>	<b>16.17</b>	<b>992.97</b>	<b>18.36</b>	<b>4.91</b>	<b>0.08</b>	<b>22.25</b>	<b>0.31</b>	<b>27.52</b>	<b>0.55</b>	<b>9992.62</b>	<b>24.28</b>	<b>0.47</b>	<b>1.33</b>	<b>0.04</b>
<b>Total</b>	<b>Total Emissions</b>	<b>544.17</b>	<b>18.74</b>	<b>1086.37</b>	<b>37.42</b>	<b>1005.45</b>	<b>48.09</b>	<b>4.93</b>	<b>0.15</b>	<b>22.31</b>	<b>0.59</b>	<b>28.01</b>	<b>1.68</b>	<b>21538.25</b>	<b>24.66</b>	<b>1.38</b>	<b>1.37</b>	<b>0.14</b>
FL1-FL2 HP	<b>High Pressure Gas Flaring (No Pilot)</b>	<b>538.72</b>	<b>6.82</b>	<b>1075.48</b>	<b>13.61</b>	<b>979.27</b>	<b>12.36</b>	<b>4.87</b>	<b>0.06</b>	<b>22.17</b>	<b>0.28</b>	<b>27.05</b>	<b>0.34</b>	<b>8456.44</b>	<b>23.90</b>	<b>0.30</b>	<b>1.28</b>	<b>0.02</b>
FL1-FL2 LP	<b>Low Pressure Gas Flaring (No Pilot)</b>	<b>4.79</b>	<b>9.00</b>	<b>9.56</b>	<b>17.98</b>	<b>25.23</b>	<b>31.61</b>	<b>0.05</b>	<b>0.06</b>	<b>0.11</b>	<b>0.18</b>	<b>0.95</b>	<b>1.30</b>	<b>9593.11</b>	<b>0.76</b>	<b>1.05</b>	<b>0.09</b>	<b>0.13</b>







**XTO ENERGY, INC.**  
**BULLDOG COMPRESSOR STATION**  
**HPF FLARE BLOWDOWN GAS ROUTED TO FLARE (EXAMPLE CALCULATION)**

**Greenhouse Gas Emissions Sample Calculation**

1)  $E_{s,CH_4} = V_a * X_{CH_4} * [(1 - \eta) * Z_L + Z_U]$  = **11,053.82** SCF/Yr  
 $V_a = 951,570.00$   
 $X_{CH_4} = 0.580820292$   
 $N = 0.98$   
 $Z_L = 1.00$   
 $Z_U = 0.00$

Source	Annual Volume
17. HPF Blowdowns	951,570.00
<b>Total</b>	<b>951,570.00</b>

2)  $E_{s,CO_2} \text{ (uncombusted)} = V_a * X_{CO_2}$  = **2,447.09** SCF/Yr  
 $V_a = 951,570.00$   
 $X_{CO_2} = 0.0026$

3)  $E_{s,CO_2} \text{ (combusted)} = \sum (\eta * V_a * Y_j * R_j * Z_L)$   
 $N = 0.98$   
 $V_a = 951,570.00$   
 $Z_L = 1.00$

$Y_j =$		$R_j =$	$E_{a,CO_2} =$
Methane	0.5808	1	541,637.34
Ethane	0.1832	2	341,643.21
Propane	0.1260	3	352,523.10
Butane	0.0654	4	243,978.51
Pentane +	0.0280	5	130,567.61
			<b>1,610,349.77</b> SCF/Yr

4)  $Mass_{s,i} = E_{s,i} * \rho_i * 10^3$   
 $E_{s,i} \text{ (CH}_4\text{)} = 11,053.82$   
 $E_{s,i} \text{ (CO}_2\text{)} = 1,612,796.86$   
 $p_i \text{ (CH}_4\text{)} = 0.0192 \text{ kg/ft}^3 = 0.21 \text{ metric tons}$   
 $p_i \text{ (CO}_2\text{)} = 0.0526 \text{ kg/ft}^3 = 84.83 \text{ metric tons}$

5)  $CO_2e = CO_2 + (CH_4 * GWP)$  short tons  $CO_2e$   
 $CO_2 = 84.83 = 93.51 \text{ } 93.51$   
 $CH_4 = 0.21 = 0.23 \text{ } 5.85$   
 $CH_4 \text{ GWP} = 25 \text{ } 99.36$

**Footnotes:**

<sup>a</sup> Source is 40 CFR § 98.233 (n), 40 CFR § 98.233(v) for CH4 and CO2 mass emissions, 40 CFR § 98.233(z) for N2O mass emissions,

**XTO ENERGY INC.**  
**BULLDOG COMPRESSOR STATION**  
**DEHYDRATORS 1-3 VAPORS ROUTED TO VAPOR COMBUSTOR (VC1)**

VOC/HAP Emissions for Dehydration Units (DEHY1 - DEHY3) - Routed to Vapor Combustor (VC1)

Uncontrolled Maximum Hourly Emission Rates and Composition to Combustion Device(s) <sup>a</sup>									
Stream	Pilot Emissions		DEHY1-3 Still Column Emissions		Total Vapors to Combustion Device(s) (Uncontrolled)		Destruction Efficiency (%)	Total Combustion Device(s) Exhaust (controlled)	
	Promax Stream Name	24. VC1 Pilot Fuel (lb/hr)	24. VC1 Pilot Fuel (ton/yr)	13. BTEX Cond Vapors to Combustion (lb/hr)	13. BTEX Cond Vapors to Combustion (ton/yr)	(lb/hr)		(ton/yr)	(lb/hr)
Triethylene Glycol	0.00	9.67E-05	0.00	1.74E-07	0.00	0.00	98%	0.00	0.00
Water	0.00	2.16E-03	1.87	8.20	1.87	8.20	0%	1.87	8.20
Hydrogen Sulfide	0.00	9.57E-04	0.15	0.67	0.15	0.67	98%	0.00	0.01
Carbon Dioxide	0.04	0.16	2.39	10.47	2.43	10.63	0%	2.43	10.63
Nitrogen	0.17	0.74	0.02	0.07	0.18	0.81	0%	0.18	0.81
Methane	8.11	35.54	9.50	41.62	17.61	77.15	98%	0.35	1.54
Ethane	2.56	11.21	22.15	97.03	24.71	108.24	98%	0.49	2.16
Propane	1.76	7.71	38.47	168.51	40.23	176.22	98%	0.80	3.52
Isobutane	0.28	1.25	6.77	29.63	7.05	30.88	98%	0.14	0.62
n-Butane	0.63	2.75	27.45	120.23	28.08	122.98	98%	0.56	2.46
Isopentane	0.14	0.63	10.71	46.93	10.86	47.56	98%	0.22	0.95
n-Pentane	0.15	0.65	14.75	64.59	14.90	65.24	98%	0.30	1.30
i-C6	0.08	0.34	10.17	44.56	10.25	44.90	98%	0.21	0.90
i-C7	0.02	0.08	2.99	13.08	3.01	13.16	98%	0.06	0.26
Octane	0.00	0.01	0.31	1.36	0.31	1.36	98%	0.01	0.03
Nonane	0.00	3.84E-04	0.02	0.07	0.02	0.07	98%	0.00	0.00
Benzene	0.00	0.01	7.52	32.95	7.52	32.96	98%	0.15	0.66
Toluene	0.00	3.38E-03	3.74	16.36	3.74	16.36	98%	0.07	0.33
Ethylbenzene	0.00	5.06E-05	0.03	0.15	0.03	0.15	98%	0.00	0.00
o-Xylene	0.00	3.32E-04	0.36	1.58	0.36	1.58	98%	0.01	0.03
n-Hexane	0.03	0.12	4.14	18.14	4.17	18.26	98%	0.08	0.37
2,2,4-Trimethylpentane	0.00	--	0.00	--	0.00	0.00	98%	0.00	0.00
Decanes Plus	0.00	1.66E-06	0.00	8.82E-04	0.00	0.00	98%	0.00	0.00
Decanes Plus Sat	0.00	--	0.00	--	0.00	0.00	98%	0.00	0.00
<b>Total</b>	<b>13.97</b>	<b>61.18</b>	<b>163.52</b>	<b>716.20</b>	<b>177.48</b>	<b>777.38</b>	<b>--</b>	<b>7.94</b>	<b>34.79</b>
<b>Total VOC</b>	<b>3.09</b>	<b>13.54</b>	<b>127.43</b>	<b>558.14</b>	<b>130.52</b>	<b>571.69</b>	<b>--</b>	<b>2.61</b>	<b>11.43</b>
<b>Total HAP</b>	<b>0.03</b>	<b>0.13</b>	<b>15.80</b>	<b>69.18</b>	<b>15.83</b>	<b>69.31</b>	<b>--</b>	<b>0.32</b>	<b>1.39</b>
Heating Value (Btu/scf)	1,269.31	1,269.31	2,460.05	2,460.05	2,460.05	2,460.05			
Molecular Weight (lb/lbmol)	21.20	21.20	44.85	44.85	--	--			
Operating Hours (hr/yr)	8,760	8,760	8,760	8,760	--	--			
Mass Flow	13.97 lb/hr	61.18 ton/yr	127.87 lb/hr	560.09 ton/yr	127.87 lb/hr	560.09 ton/yr			
Volumetric Flow	250 scf/hr	2 MMscf/yr	1,082 scf/hr	9 MMscf/yr	1,332 scf/hr	12 MMscf/yr			
Heat Release (MMBtu/hr)	0.32 MMBtu/hr	2,779.79 MMBtu/yr	2.66 MMBtu/hr	23,315.17 MMBtu/yr	3.28 MMBtu/hr	23,315.17 MMBtu/yr			

Criteria Pollutant Emissions Combustion Device(s) <sup>b</sup>			
Component	Emission Rate (lb/hr)	Emission Factor	Emission Factor Units
NO <sub>x</sub>	0.45	0.138	lb/MMBtu
CO	0.90	0.2755	lb/MMBtu
SO <sub>2</sub>	0.29	--	--
PM <sub>10</sub>	0.01	7.60	lb/MMscf
PM <sub>2.5</sub>	0.01	7.60	lb/MMscf
N <sub>2</sub> O	0.00	0.00022	lb/MMBtu
H <sub>2</sub> S	0.00	--	--

Combustion Device Destruction Efficiency C4+	98%
Combustion Device Efficiency C3	98%

H2S molecular weight	34.08
SO2 molecular weight	64.06
Molar Volume (scf/lbmol)	379.484
Combustor Operating Hours	8760

Combustion Emissions from Combustion Device(s)						
	(lb/hr)	(ton/yr)	(lb/hr)	(ton/yr)	(lb/hr)	(ton/yr)
Total NO <sub>x</sub>	0.04	0.19	0.37	1.61	0.41	1.80
Total CO	0.09	0.38	0.73	3.21	0.82	3.59
Total SO <sub>2</sub>	0.00	1.80E-03	0.29	1.26	0.29	1.26
Total PM <sub>10</sub>	0.002	0.01	0.008	0.04	0.01	0.04
Total PM <sub>2.5</sub>	0.00	0.01	0.01	0.04	0.01	0.04
Total VOC (slip)	0.06	0.27	2.55	11.16	2.61	11.43
Total HAP (slip)	0.00	2.59E-03	0.32	1.38	0.32	1.39
Total n-Hexane (slip)	0.00	0.00	0.08	0.36	0.08	0.37
Total Benzene (slip)	0.00	0.00	0.15	0.66	0.15	0.66
Total CH <sub>4</sub>	0.12	0.54	0.07	0.30	0.19	0.84
Total N <sub>2</sub> O	0.000	6.76E-04	0.001	0.01	0.00	0.01
Total CO <sub>2</sub>	49.41	216.43	559.83	2,452.05	609.24	2,668.48
Total CO <sub>2e</sub>	52.53	230.09	561.92	2,461.19	614.45	2,691.28

Large Glycol Unit - MACT HH Check		
# of Units	3	Limit
Flow per Dehy	10,655	85,000 SCF/Day
Benzene Emissions	0.22	1 ton/yr

**Footnotes:**

- <sup>a</sup> Uncontrolled stream properties determined via ProMax.
- <sup>b</sup> Flare CO and NO<sub>x</sub> emission factors from TCEQ Air Permit Technical Guidance for Chemical Sources. PM and PM<sub>2.5</sub> emission factors from AP-42, Table 1.4-1 and 1.4-2, July 1998. SO<sub>2</sub> emissions assume 100% conversion of H<sub>2</sub>S to SO<sub>2</sub>.
- <sup>c</sup> Flash tank emissions are routed back to inlet slug catcher.



XTO ENERGY, INC.  
 BULLDOG COMPRESSOR STATION  
 ROAD EMISSIONS

<b>Total Suspended Particle Emissions</b>	
$E = k(sL/2)^a(W/3)^b$	
a	0.7
b	0.45
k	4.9
Silt %	4.8
Vehicle Weight (tons)	28
E (lbs/VMT)	7.05
Rain Days	70
E-Annual (lbs/VMT)	5.70
Truckloads per year	210
Driving Distance Per Load (ft)	1000
Annual Distance (miles)	40
Control Efficiency - 15 MPH Limit	0.44
Emissions (lbs/hr)	0.60
Emissions (tpy)	0.06

<b>PM<sub>10</sub> Emissions</b>	
$E = k(sL/2)^a(W/3)^b$	
a	0.9
b	0.45
k	1.5
Silt %	4.8
Vehicle Weight (tons)	28
E (lbs/VMT)	1.80
Rain Days	70
E-Annual (lbs/VMT)	1.45
Truckloads per day	210
Driving Distance Per Load (ft)	1000
Annual Distance (miles)	40
Control Efficiency - 15 MPH Limit	0.44
Emissions (lbs/hr)	0.15
Emissions (tpy)	0.02

<b>PM<sub>2.5</sub> Emissions</b>	
$E = k(sL/2)^a(W/3)^b$	
a	0.9
b	0.45
k	0.15
Silt %	4.8
Vehicle Weight (tons)	28
E (lbs/VMT)	0.18
Rain Days	70
E-Annual (lbs/VMT)	0.15
Truckloads per day	210
Driving Distance Per Load (ft)	1000
Annual Distance (miles)	40
Control Efficiency - 15 MPH Limit	0.44
Emissions (lbs/hr)	0.02
Emissions (tpy)	0.00

Emissions (lbs/hr) = Driving Distance (ft)/ 5280 \* E (lbs/VMT)  
 Emissions (tpy) = Annual Distance \* E / 2000

References:

EPA. "Compilation of Air Pollutant Emission Factors, Volume 1: Stationary Point and Area Sources," Section 13.2.2 AP-42, Office of Air Quality Planning and Standards, Research Triangle Park, NC. 5th edition (11/2006).

**XTO ENERGY, INC.**  
**BULLDOG COMPRESSOR STATION**  
**FUGITIVE EMISSIONS**

**FUGITIVE EMISSIONS CALCULATIONS**

<b>Operating Hours:</b>	8760 hours/year
<b>Emission Factor Source</b>	Standard EFs - EPA-453/R-95-017 Table 2-4
<b>Control Efficiency Source:</b>	None
<b>Emission Buffer (%):</b>	0

Service	Component Type	Count	Emission Factor (lb/hr-source) <sup>a</sup>		Control (%) <sup>b</sup>	Pollutant	Mass Fraction <sup>c</sup>	Uncontrolled Emissions (lb/hr)	Uncontrolled Emissions (tpy)	Controlled Emissions (lb/hr)	Controlled Emissions (tpy)
			Table 2-4	Table 2-8							
Gas	Valves	720	9.92E-03	5.51E-05	0.0%	VOC	0.300	2.6726	11.7061	2.6726	11.7061
	Pump Seals	0	5.29E-03	7.72E-04	0.0%	H2S	0.000	0.0001	0.0004	0.0001	0.0004
	Connectors	1440	4.41E-04	2.20E-05	0.0%	Benzene	0.001	0.0045	0.0199	0.0045	0.0199
	Flanges	720	8.60E-04	1.26E-05	0.0%	Toluene	0.001	0.0072	0.0316	0.0072	0.0316
	Open-Ended Lines	72	4.41E-03	3.31E-05	0.0%	E-Benzene	0.000	0.0004	0.0020	0.0004	0.0020
	Other	10	1.94E-02	2.65E-04	0.0%	Xylenes	0.000	0.0041	0.0179	0.0041	0.0179
	Relief Valves	0	1.94E-02	2.65E-04	0.0%	n-Hexane	0.008	0.0742	0.3250	0.0742	0.3250
					2,2,4 Trimethylpentane	0.000	0.0000	0.0000	0.0000	0.0000	0.0000
Heavy Oil	Valves	0	1.85E-05	1.85E-05	0.0%	VOC	0.978	0.0000	0.0000	0.0000	0.0000
	Pump Seals	0	0.00E+00	0.00E+00	0.0%	H2S	0.000	0.0000	0.0000	0.0000	0.0000
	Connectors	0	1.65E-05	1.65E-05	0.0%	Benzene	0.015	0.0000	0.0000	0.0000	0.0000
	Flanges	0	8.60E-06	8.60E-07	0.0%	Toluene	0.005	0.0000	0.0000	0.0000	0.0000
	Open-Ended Lines	0	3.09E-04	1.59E-05	0.0%	E-Benzene	0.012	0.0000	0.0000	0.0000	0.0000
	Other	0	3.09E-04	7.05E-05	0.0%	Xylenes	0.001	0.0000	0.0000	0.0000	0.0000
	Relief Valves	0	3.09E-04	7.05E-05	0.0%	n-Hexane	0.007	0.0000	0.0000	0.0000	0.0000
					2,2,4 Trimethylpentane	0.085	0.0000	0.0000	0.0000	0.0000	0.0000
Light Oil	Valves	236	5.51E-03	4.19E-05	0.0%	VOC	0.978	1.9625	8.5958	1.9625	8.5958
	Pump Seals	15	2.87E-02	1.12E-03	0.0%	H2S	0.000	0.0000	0.0000	0.0000	0.0000
	Connectors	472	4.63E-04	2.14E-05	0.0%	Benzene	0.015	0.0303	0.1327	0.0303	0.1327
	Flanges	236	2.43E-04	5.29E-06	0.0%	Toluene	0.005	0.0100	0.0438	0.0100	0.0438
	Open-Ended Lines	0	2.87E-03	3.09E-05	0.0%	E-Benzene	0.012	0.0242	0.1058	0.0242	0.1058
	Other	0	1.65E-02	2.43E-04	0.0%	Xylenes	0.001	0.0026	0.0112	0.0026	0.0112
	Relief Valves	0	1.65E-02	2.43E-04	0.0%	n-Hexane	0.007	0.0135	0.0593	0.0135	0.0593
					2,2,4 Trimethylpentane	0.085	0.1713	0.7502	0.1713	0.7502	
Water/Oil	Valves	153	2.16E-04	2.14E-05	0.0%	VOC	0.978	0.2573	1.1272	0.2573	1.1272
	Pump Seals	10	5.29E-05	5.29E-05	0.0%	H2S	0.000	0.0000	0.0000	0.0000	0.0000
	Connectors	306	2.43E-04	2.20E-05	0.0%	Benzene	0.015	0.0040	0.0174	0.0040	0.0174
	Flanges	153	6.39E-06	6.39E-06	0.0%	Toluene	0.005	0.0013	0.0057	0.0013	0.0057
	Open-Ended Lines	0	5.51E-04	7.72E-06	0.0%	E-Benzene	0.012	0.0032	0.0139	0.0032	0.0139
	Other	5	3.09E-02	1.30E-04	0.0%	Xylenes	0.001	0.0003	0.0015	0.0003	0.0015
	Relief Valves	0	3.09E-02	1.30E-04	0.0%	n-Hexane	0.007	0.0018	0.0078	0.0018	0.0078
					2,2,4 Trimethylpentane	0.085	0.0225	0.0984	0.0225	0.0984	

**Fugitive Emission Summary**

Pollutant	Uncontrolled Emissions		Controlled Emissions	
	(lb/hr)	(tpy)	(lb/hr)	(tpy)
VOC	4.89	21.43	4.89	21.43
HAPs	0.38	1.64	0.38	1.64
H2S	0.00	0.00	0.00	0.00
Benzene	0.04	0.17	0.04	0.17
Toluene	0.02	0.08	0.02	0.08
E-Benzene	0.03	0.12	0.03	0.12
Xylenes	0.01	0.03	0.01	0.03
n-Hexane	0.09	0.39	0.09	0.39
2,2,4 Trimethylpentane	0.19	0.85	0.19	0.85

**Footnotes:**

<sup>a</sup> Factors are taken from EPA Document EPA-453/R-095-017, November 1995, Table 2-4

<sup>b</sup> Control efficiencies are taken from EPA Document EPA-453/R-095-017, November 1995, Table 5-2

<sup>c</sup> Gas/Vapor based inlet gas. Heavy Oil, Light Oil, and Water/Oil fugitives were based on liquid analysis of inlet separator hydrocarbon liquid.

**XTO ENERGY, INC.**  
**BULLDOG COMPRESSOR STATION**  
**FACILITY INLET GAS ANALYSIS - PROMAX**

**Gas Composition**

Component	Mole %	Weight %
TEG	0.000	0.0000
Water	0.000	0.0000
Hydrogen Sulfide	0.001	0.0010
Carbon Dioxide	0.121	0.2330
Nitrogen	0.864	1.0580
Methane	73.632	51.6360
Ethane	12.988	17.0720
Propane	6.704	12.9230
Isobutane	0.949	2.4110
n-Butane	2.303	5.8510
Isopentane	0.551	1.7380
n-Pentane	0.664	2.0950
Other C-6's	0.482	1.8000
Heptanes	0.327	1.4200
Octanes	0.111	0.5390
Nonanes	0.032	0.1770
Benzene	0.015	0.0510
Toluene	0.020	0.0810
E-Benzene	0.001	0.0050
Xylenes	0.010	0.0460
n-Hexane	0.221	0.8330
2,2,4 Trimethylpentane	0.000	0.0000
Decanes Plus	0.005	0.0310
Decanes Plus Satellite	0.000	0.0000
Total	100.001	100.0010

MOLECULAR WEIGHT	22.88
SATURATED BTU	1371
NMHC (WT%)	47.073
VOCs (WT%)	30.00
HAPs (WT%)	1.02
H2S (MOL%)	0.00

**XTO ENERGY, INC.**  
**BULLDOG COMPRESSOR STATION**  
**FACILITY INLET FLUID ANALYSIS - PROMAX**

**Fluid Composition**

Component	Mole %	Weight %
TEG	0.0000	0.0000
Water	0.0000	0.0000
Hydrogen Sulfide	0.0000	0.0000
Carbon Dioxide	0.0129	0.0075
Nitrogen	0.0167	0.0062
Methane	2.8473	0.6026
Ethane	3.9579	1.5701
Propane	8.4770	4.9315
Isobutane	3.2673	2.5054
n-Butane	12.1250	9.3186
Isopentane	8.1300	7.7386
n-Pentane	12.6670	12.0571
Other C-6's	7.9339	9.0203
Heptanes	17.1885	20.9987
Octanes	10.5388	14.6036
Nonanes	1.6426	2.7426
Benzene	0.7463	1.5099
Toluene	0.4833	0.4981
E-Benzene	0.9907	1.2043
Xylenes	0.0912	0.1277
n-Hexane	0.4815	0.6744
2,2,4 Trimethylpentane	7.5090	8.5370
Decanes Plus	0.8930	1.3457
Decanes Plus Satellite	0.0000	0.0000
Total	100.000	100.0000

MOLECULAR WEIGHT	75.80
SATURATED BTU	
NMHC (WT%)	99.38
VOCs (WT%)	97.81
HAPs (WT%)	12.55
H2S (MOL%)	0.000

**Tab 7**  
**Section 7 - Information Used To Determine**  
**Emissions**

# Section 7

## Information Used To Determine Emissions

---

**Information Used to Determine Emissions shall include the following:**

- If manufacturer data are used, include specifications for emissions units and control equipment, including control efficiencies specifications and sufficient engineering data for verification of control equipment operation, including design drawings, test reports, and design parameters that affect normal operation.
  - If test data are used, include a copy of the complete test report. If the test data are for an emissions unit other than the one being permitted, the emission units must be identical. Test data may not be used if any difference in operating conditions of the unit being permitted and the unit represented in the test report significantly effect emission rates.
  - If the most current copy of AP-42 is used, reference the section and date located at the bottom of the page. Include a copy of the page containing the emissions factors, and clearly mark the factors used in the calculations.
  - If an older version of AP-42 is used, include a complete copy of the section.
  - If an EPA document or other material is referenced, include a complete copy.
  - Fuel specifications sheet.
  - If computer models are used to estimate emissions, include an input summary (if available) and a detailed report, and a disk containing the input file(s) used to run the model. For tank-flashing emissions, include a discussion of the method used to estimate tank-flashing emissions, relative thresholds (i.e., permit or major source (NSPS, PSD or Title V)), accuracy of the model, the input and output from simulation models and software, all calculations, documentation of any assumptions used, descriptions of sampling methods and conditions, copies of any lab sample analysis.
- 

The Bulldog Compressor Station gas inlet composition was obtained from the Muy Wano 18 Tank Battery Inlet Separator hydrocarbon gas sample. The Muy Wano 18 Tank Battery gas analysis is representative of the hydrocarbons from the surrounding wells and batteries. The sales gas composition from this battery was used as the inlet gas composition for the station in the ProMax process simulation.

A liquid sample was taken from the Wolverine Compressor station Inlet Separator Hydrocarbon liquid sample was used for the decanes plus speciation in the ProMax process simulation.

All supporting documentation is provided in this section.

# BULLDOG COMPRESSOR STATION

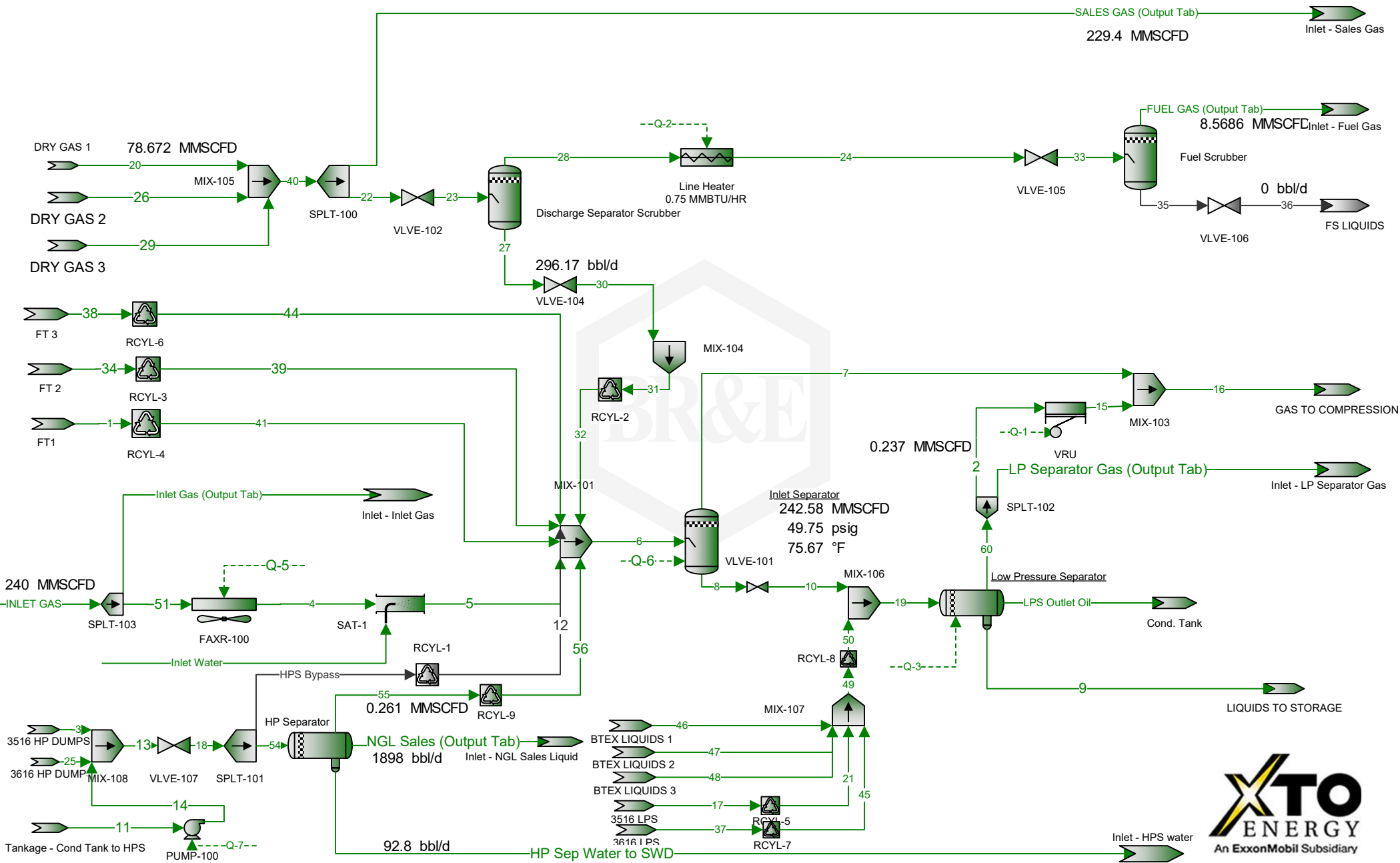

# BULLDOG COMPRESSOR STATION

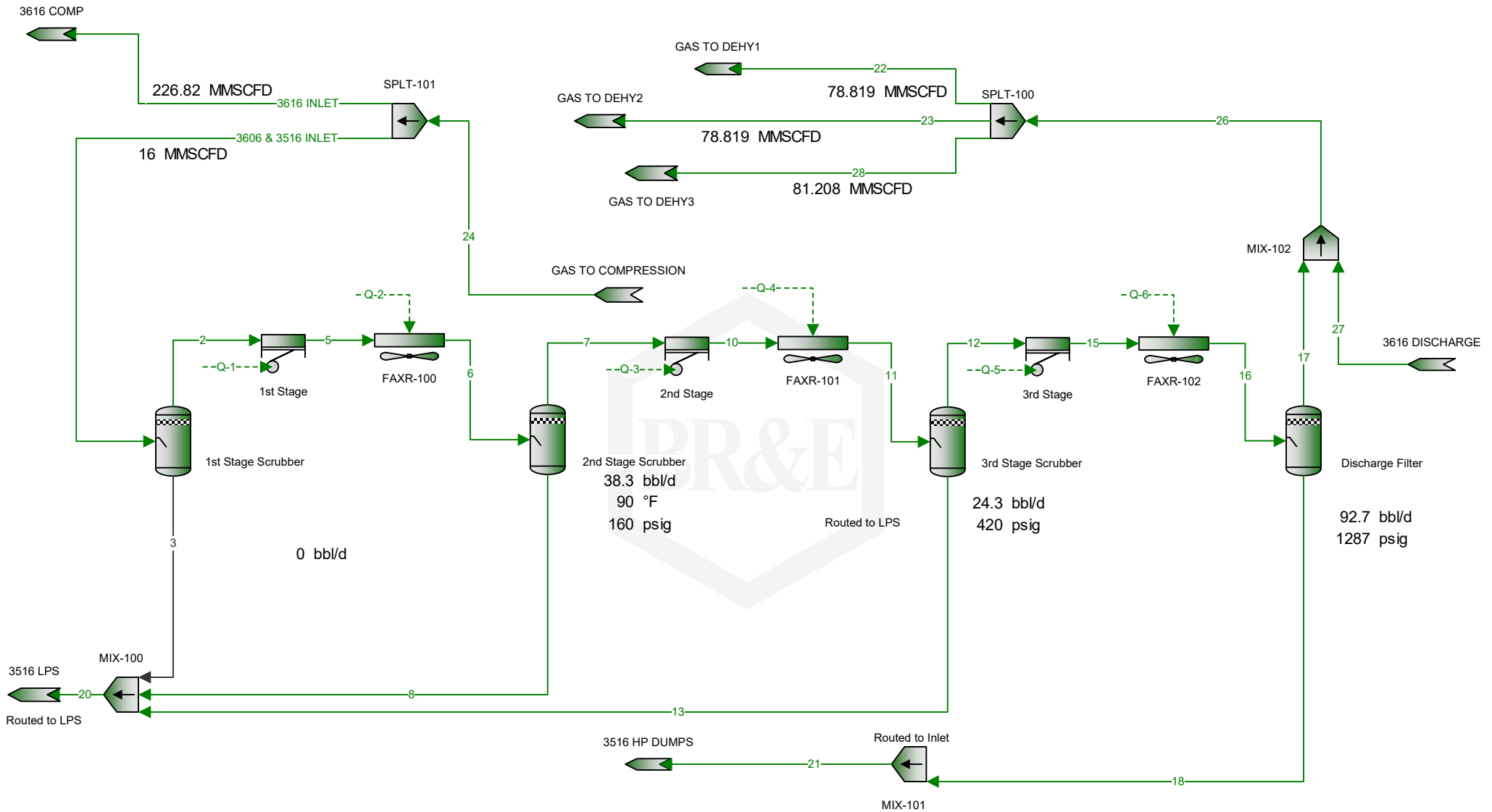



# BULLDOG COMPRESSOR STATION

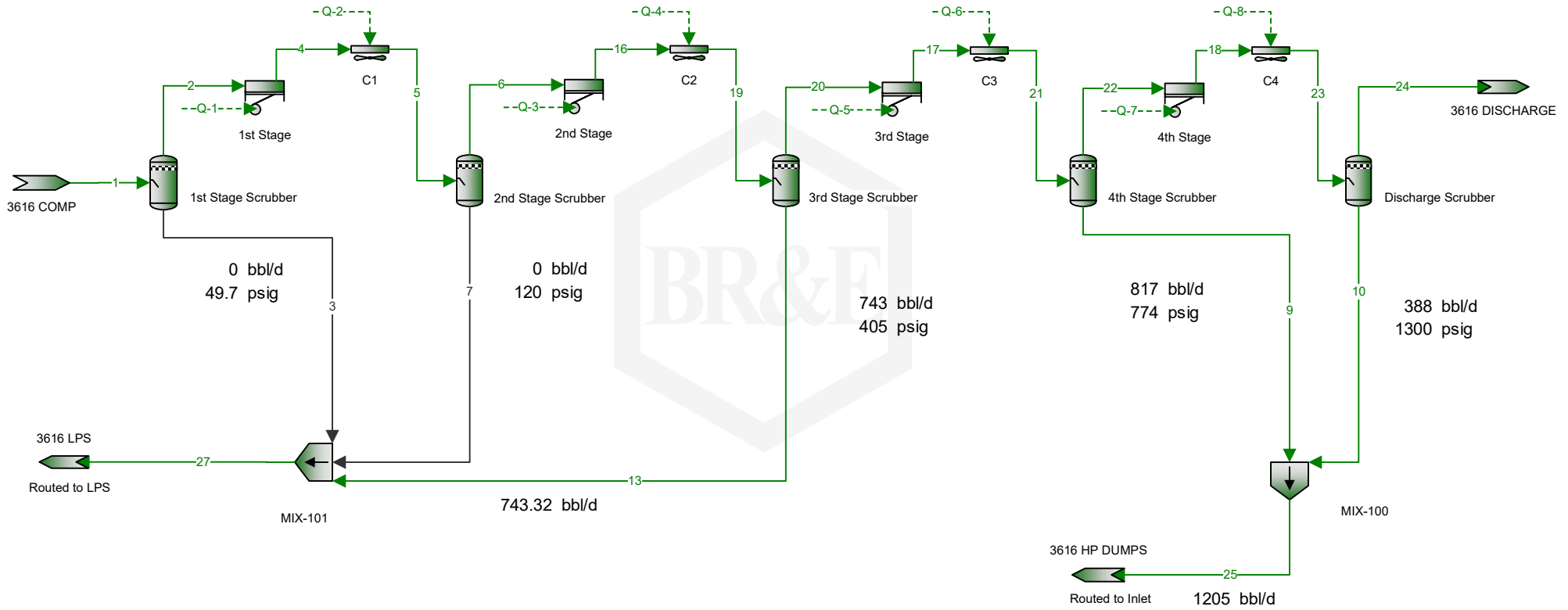

# BULLDOG COMPRESSOR STATION

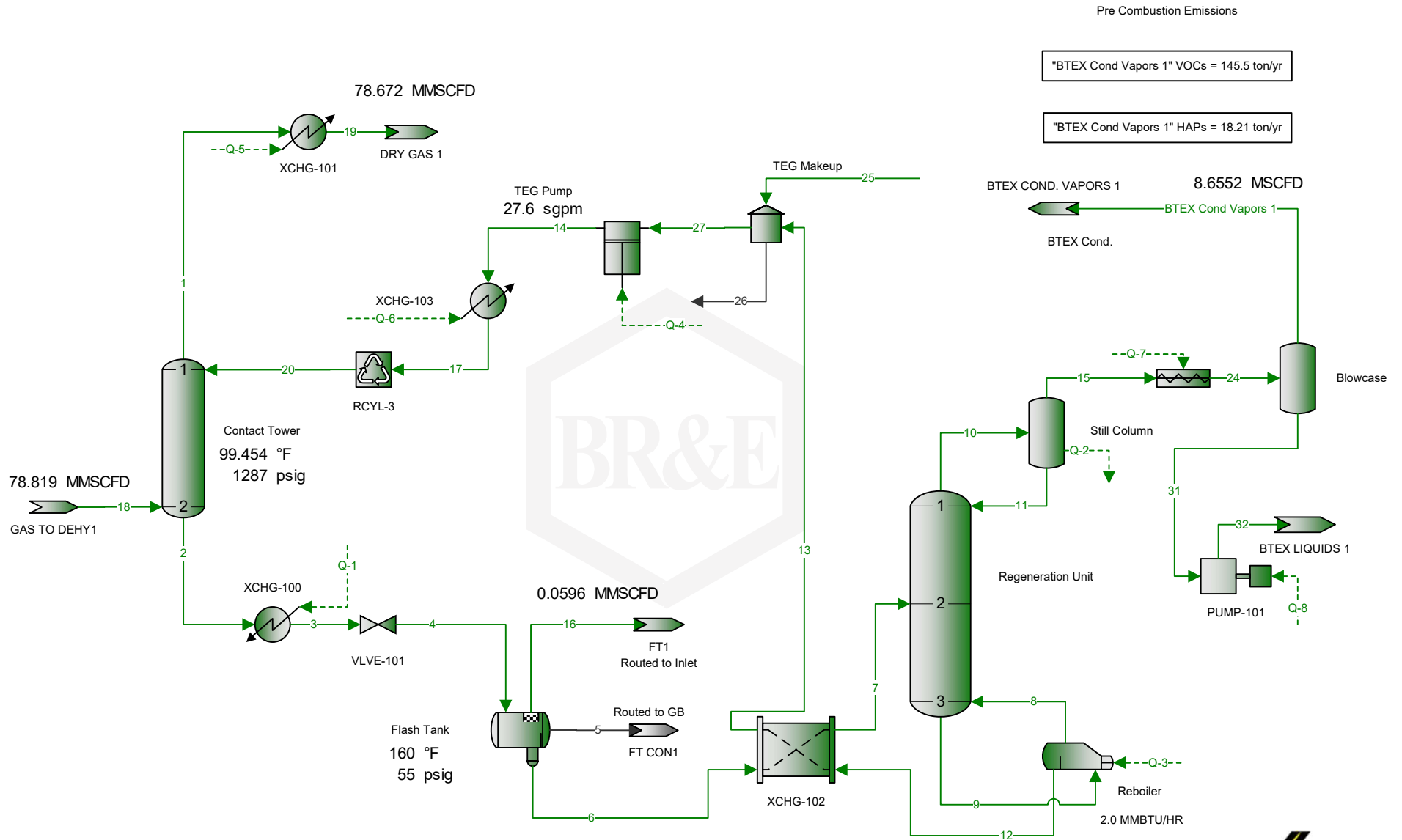

# BULLDOG COMPRESSOR STATION

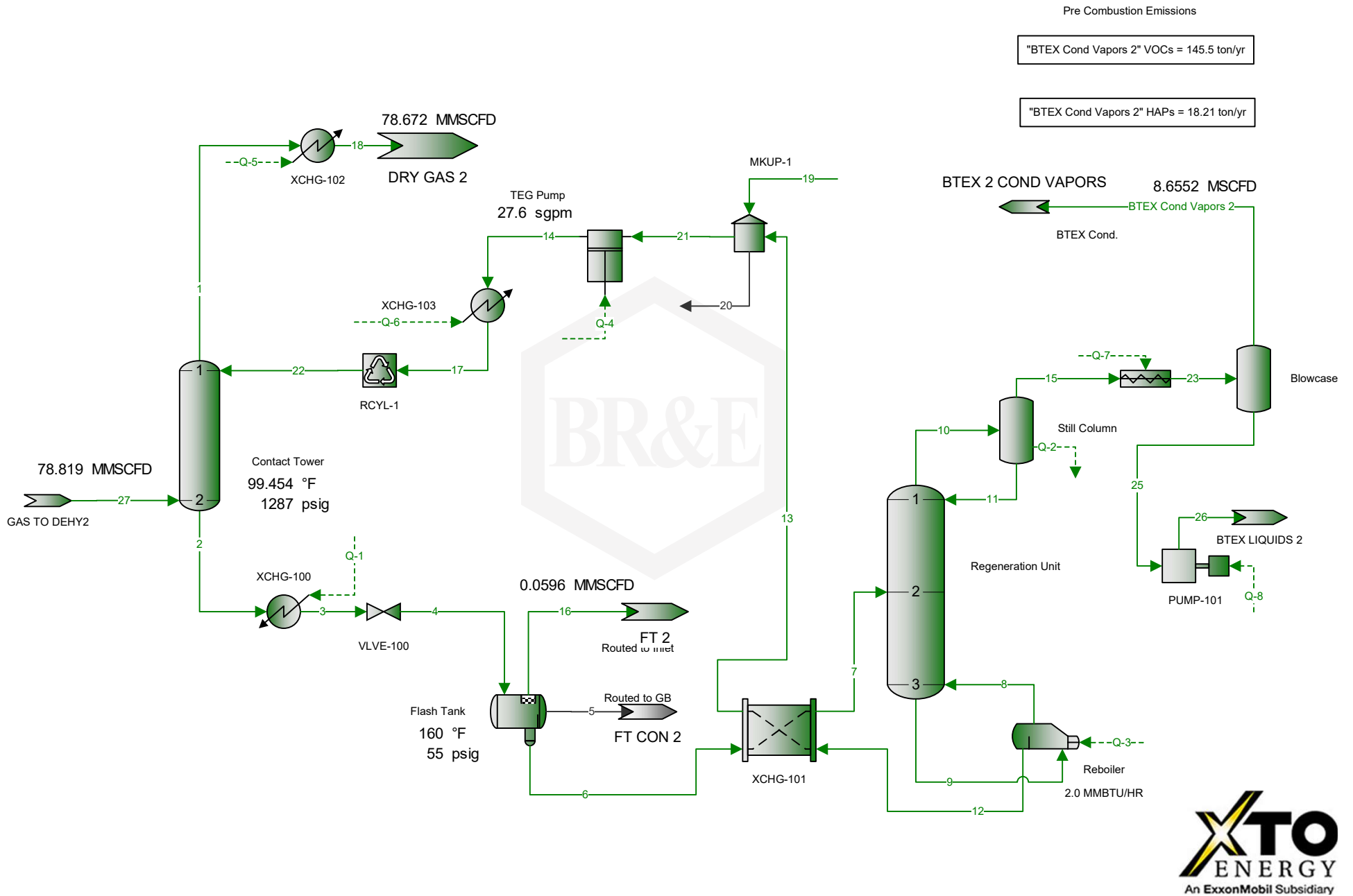

# BULLDOG COMPRESSOR STATION

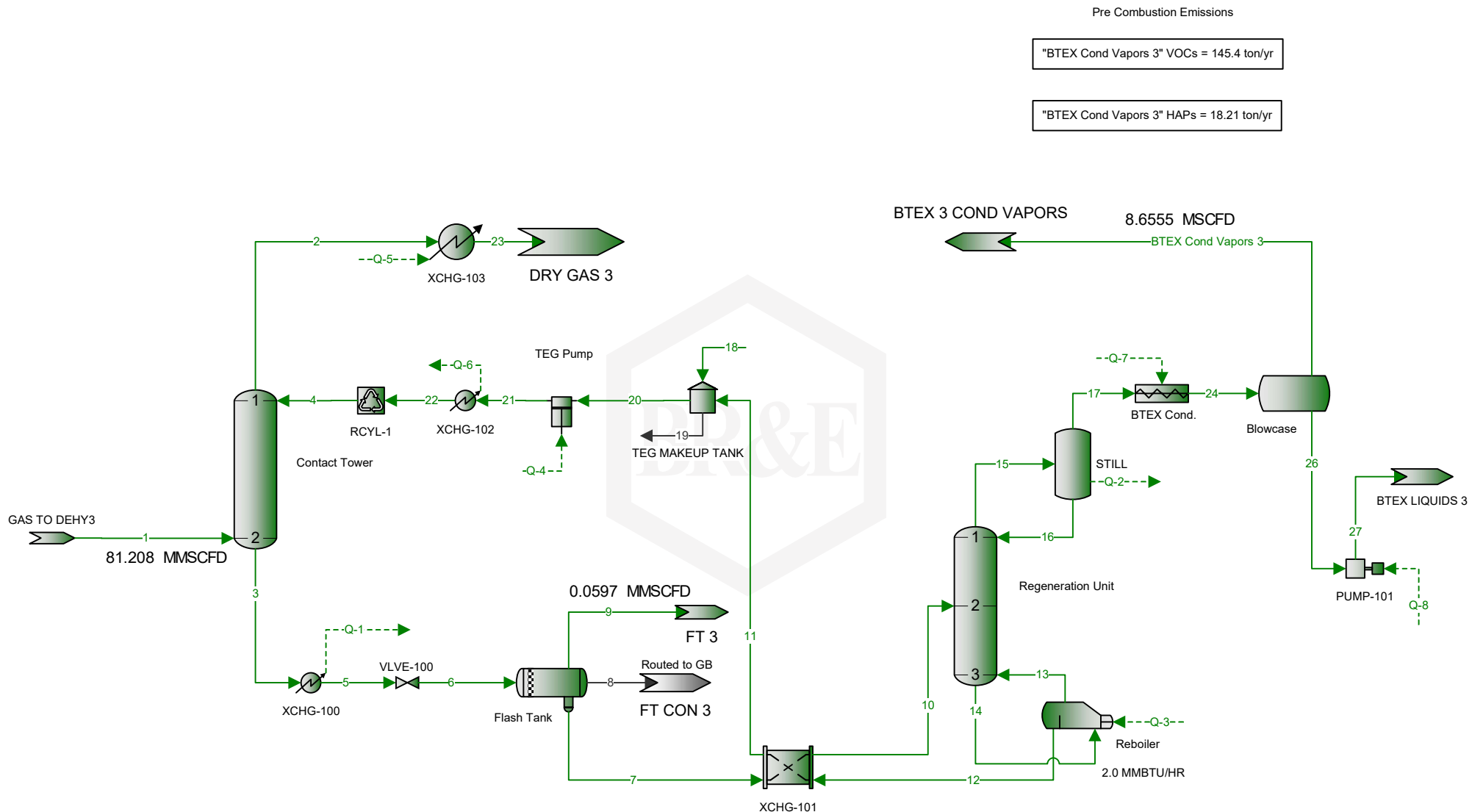

# BULLDOG COMPRESSOR STATION

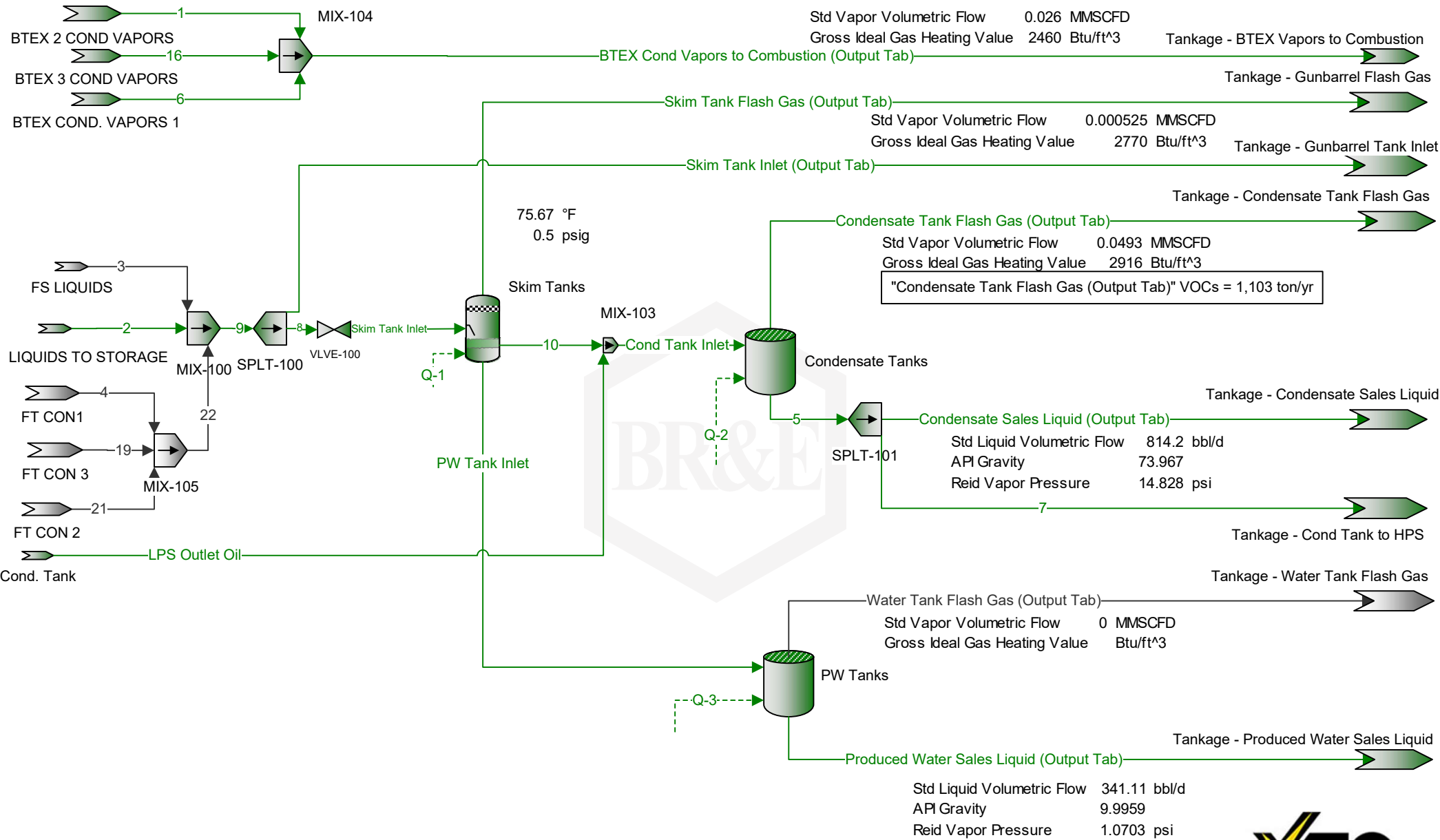

Added flow multiplier prior to condensate tank



# BULLDOG COMPRESSOR STATION

Std Liquid Volumetric Flow 345.76 bbl/d  
 Reid Vapor Pressure 4.4213 psi  
 True Vapor Pressure 5.2562 psia

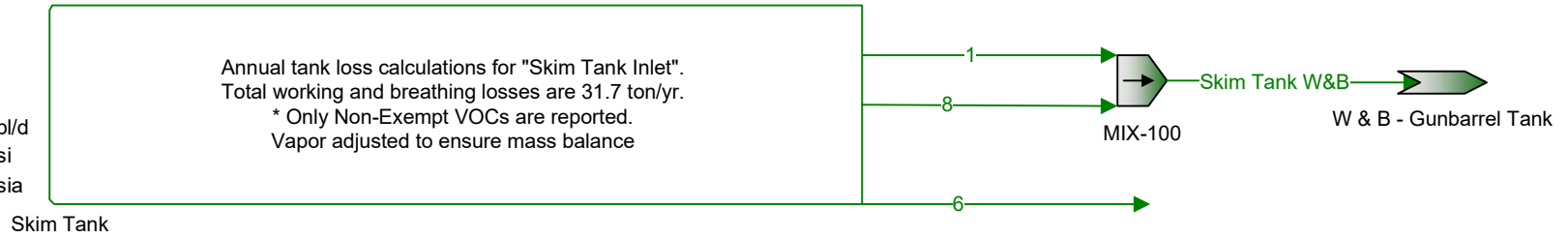

Std Liquid Volumetric Flow 777.45 bbl/d  
 Reid Vapor Pressure 11.806 psi  
 True Vapor Pressure 13.65 psia

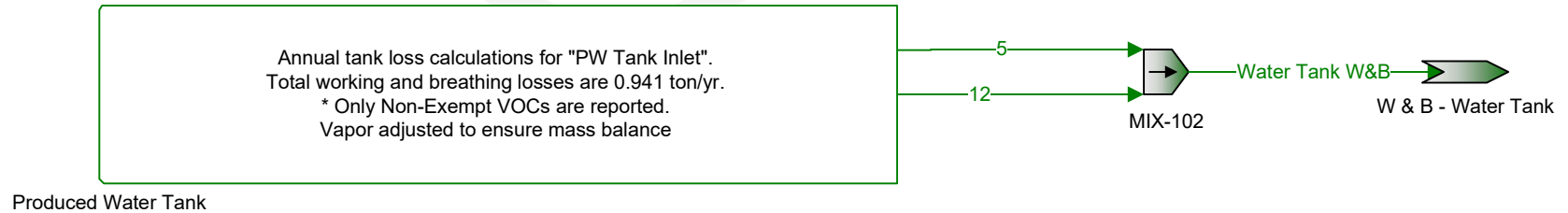
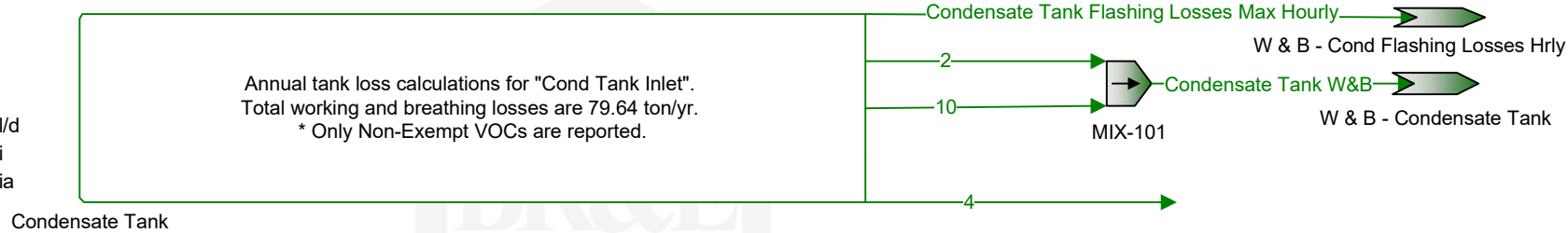

# BULLDOG COMPRESSOR STATION

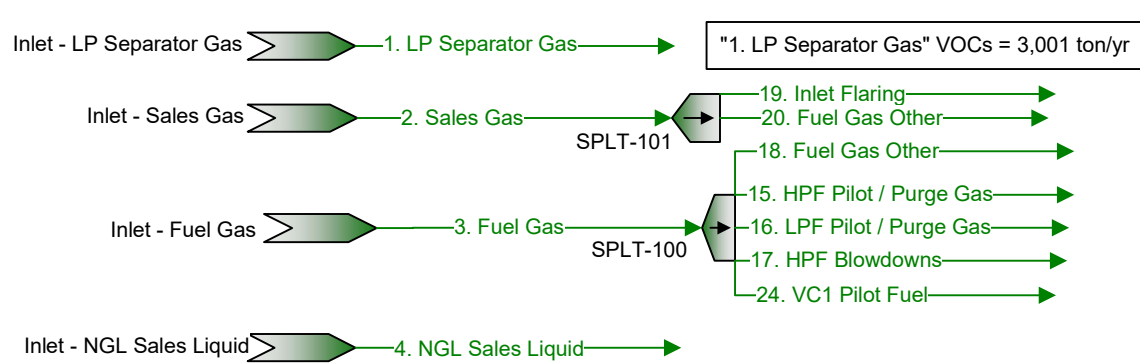

Properties		1. LP Separator Gas	
Std Vapor Volumetric Flow		0.237	MMSCFD

Properties		2. Sales Gas	
Std Vapor Volumetric Flow		229	MMSCFD

Properties		3. Fuel Gas	
Std Vapor Volumetric Flow		8.57	MMSCFD

Properties		4. NGL Sales Liquid	
Std Liquid Volumetric Flow		1898	bb/d

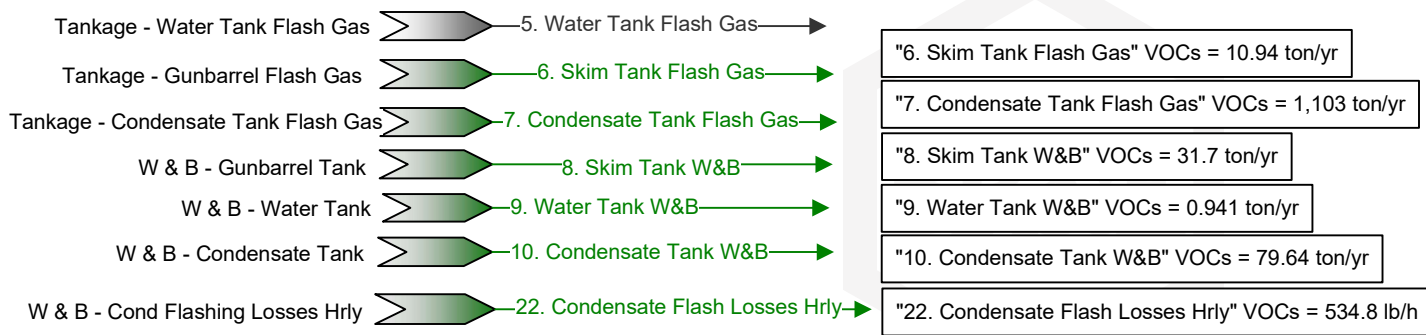

Properties		11. Condensate Sales Liquid	
Std Liquid Volumetric Flow		814.2	bb/d
API Gravity		74	

Properties		12. Produced Water Liquid	
Std Liquid Volumetric Flow		341.1	bb/d

Properties		14. Skim Tank Inlet	
Std Liquid Volumetric Flow		347.1	bb/d

Properties		13. BTEX Cond Vapors to Combustion	
Std Vapor Volumetric Flow		0.026	MMSCFD

Properties		21. Inlet Gas	
Std Vapor Volumetric Flow		240	MMSCFD

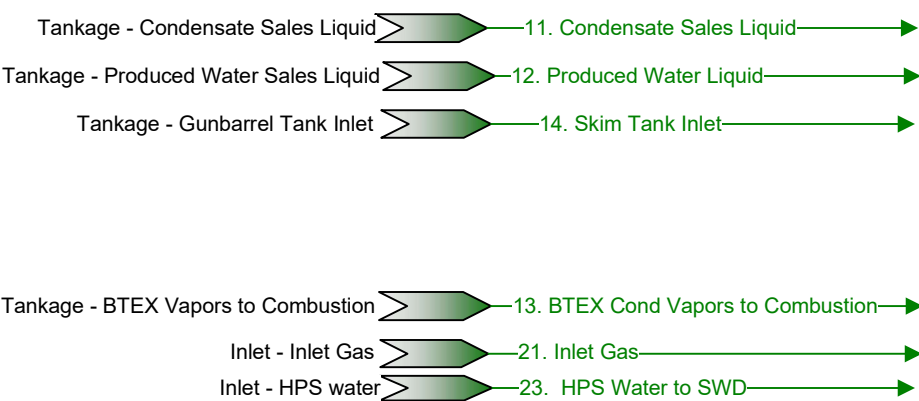

**Process Streams Report**  
**All Streams**  
 Tabulated by Total Phase

Client Name:	DELAWARE DIVISION	Job:
Location:	Bulldog Compressor Station	
Flowsheet:	Output	

**Connections**

	1. LP Separator Gas	2. Sales Gas	3. Fuel Gas	4. NGL Sales Liquid	5. Water Tank Flash Gas
From Block	Inlet - LP Separator Gas	Inlet - Sales Gas	Inlet - Fuel Gas	Inlet - NGL Sales Liquid	Tankage - Water Tank Flash Gas
To Block	--	SPLT-101	SPLT-100	--	--

**Stream Composition**

Mass Flow	1. LP Separator Gas lb/h	2. Sales Gas lb/h	3. Fuel Gas lb/h	4. NGL Sales Liquid lb/h	5. Water Tank Flash Gas lb/h
Triethylene Glycol	2.37625E-08	3.22561	0.00440314	4.28295E-08	
Water	7.45215	18.4076	0.703934	3.21159	
Hydrogen Sulfide	0.0215286	8.48825	0.312073	0.0660887	
Carbon Dioxide	1.27446	1346.94	51.3005	4.37797	
Nitrogen	0.93287	6142.43	239.69	2.01282	
Methane	126.605	299577	11586.5	399.866	
Ethane	163.713	98694	3654.16	632.061	
Propane	252.436	74204.6	2513.69	1211.24	
Isobutane	63.245	13694	406.627	456.031	
n-Butane	165.6	32941.7	898.152	1521.54	
Isopentane	50.9199	9661.03	204.434	887.67	
n-Pentane	58.4506	11081.7	211.527	1279.22	
i-C6	45.7636	8966	110.123	2169.81	
i-C7	18.6612	4063.28	25.9636	2386.48	
Octane	5.43716	1225.46	2.82376	2667.63	
Nonane	0.874389	151.26	0.125044	1224.52	
Benzene	2.30013	209.647	2.30186	112.905	
Toluene	1.87123	233.133	1.17281	311.96	
Ethylbenzene	0.0512527	8.12908	0.0183593	25.2738	
o-Xylene	0.460731	65.4087	0.123331	274.284	
n-Hexane	19.0656	3915.53	38.7864	1249.82	
2,2,4-Trimethylpentane	0	0	0	0	
Decanes Plus	0.0363429	2.21742	0.000503746	279.402	
Decanes Plus Sat	0	0	0	0	

Mole Fraction	1. LP Separator Gas %	2. Sales Gas %	3. Fuel Gas %	4. NGL Sales Liquid %	5. Water Tank Flash Gas %
Triethylene Glycol	6.0769E-10	8.52759E-05	3.11649E-06	1.17031E-10	
Water	1.58862	0.00405662	0.00415324	0.0731522	
Hydrogen Sulfide	0.00242597	0.000988813	0.000973289	0.000795728	
Carbon Dioxide	0.111214	0.121509	0.1239	0.0408202	
Nitrogen	0.12789	0.870525	0.909452	0.029484	
Methane	30.3082	74.1386	76.7678	10.228	
Ethane	20.9095	13.031	12.9171	8.62557	
Propane	21.9855	6.68101	6.05916	11.2715	
Isobutane	4.17893	0.935396	0.743618	3.21959	
n-Butane	10.9421	2.25015	1.64249	10.7421	
Isopentane	2.71044	0.53162	0.301176	5.0486	
n-Pentane	3.11129	0.609797	0.311625	7.27551	
i-C6	2.03947	0.413069	0.135828	10.3321	
i-C7	0.715228	0.160993	0.0275413	9.77305	
Octane	0.182801	0.0425924	0.00262754	9.58295	
Nonane	0.0261825	0.00468226	0.00010363	3.91776	
Benzene	0.113088	0.0106556	0.00313226	0.593121	
Toluene	0.077995	0.0100455	0.00135296	1.38933	
Ethylbenzene	0.00185403	0.000303995	1.83811E-05	0.097687	
o-Xylene	0.0166666	0.00244603	0.000123477	1.06015	
n-Hexane	0.849663	0.180391	0.0478401	5.95129	
2,2,4-Trimethylpentane	0	0	0	0	

\* User Specified Values  
 ? Extrapolated or Approximate Values

ProMax 5.0.19050.0  
 Copyright © 2002-2019 BRE Group, Ltd.

Licensed to Esso Exploration, Inc.



**Process Streams Report**  
**All Streams**  
 Tabulated by Total Phase

Client Name:	DELAWARE DIVISION	Job:
Location:	Bulldog Compressor Station	
Flowsheet:	Output	

	1. LP Separator Gas %	2. Sales Gas %	3. Fuel Gas %	4. NGL Sales Liquid %	5. Water Tank Flash Gas %
<b>Mole Fraction</b>					
Decanes Plus	0.000909861	5.73892E-05	3.49045E-07	0.747399	
Decanes Plus Sat	0	0	0	0	

	1. LP Separator Gas %	2. Sales Gas %	3. Fuel Gas %	4. NGL Sales Liquid %	5. Water Tank Flash Gas %
<b>Mass Fraction</b>					
Triethylene Glycol	2.41202E-09	0.00056968	2.20724E-05	2.50474E-10	
Water	0.75643	0.003251	0.00352874	0.0187819	
Hydrogen Sulfide	0.00218526	0.00149912	0.00156439	0.000386498	
Carbon Dioxide	0.129364	0.237886	0.257163	0.0256031	
Nitrogen	0.094691	1.08483	1.20154	0.0117713	
Methane	12.851	52.9088	58.082	2.33849	
Ethane	16.6177	17.4305	18.3179	3.6964	
Propane	25.6236	13.1054	12.6008	7.08351	
Isobutane	6.41968	2.41852	2.03837	2.66695	
n-Butane	16.8092	5.8179	4.50233	8.89825	
Isopentane	5.16863	1.70625	1.0248	5.19124	
n-Pentane	5.93303	1.95716	1.06036	7.48107	
i-C6	4.64524	1.5835	0.552033	12.6894	
i-C7	1.89421	0.717624	0.130152	13.9565	
Octane	0.551899	0.216431	0.0141552	15.6007	
Nonane	0.0887549	0.0267142	0.000626833	7.16117	
Benzene	0.233475	0.0370262	0.011539	0.660285	
Toluene	0.189939	0.041174	0.00587918	1.8244	
Ethylbenzene	0.00520241	0.00143569	9.2033E-05	0.147805	
o-Xylene	0.0467665	0.011552	0.000618245	1.60406	
n-Hexane	1.93525	0.691528	0.194432	7.30913	
2,2,4-Trimethylpentane	0	0	0	0	
Decanes Plus	0.00368899	0.000391623	2.52522E-06	1.63399	
Decanes Plus Sat	0	0	0	0	

**Stream Properties**

Property	Units	1. LP Separator Gas	2. Sales Gas	3. Fuel Gas	4. NGL Sales Liquid	5. Water Tank Flash Gas
Temperature	°F	75.7	93.2634	76.5751	94.2513	
Pressure	psig	15	1272	120	400	0.25
Molecular Weight	lb/lbmol	37.8349	22.4795	21.2035	70.1663	
Mass Flow	lb/h	985.173	566214	19948.6	17099.4	0
Std Vapor Volumetric Flow	MMSCFD	0.237151	229.402	8.56858	2.21951	0
Std Liquid Volumetric Flow	sgpm	4.19696	3145.36	114.762	55.3492	0
API Gravity					90.3641	
Gross Ideal Gas Heating Value	Btu/ft <sup>3</sup>	2154.4	1338.01	1269.3	3872.94	

Remarks

<b>Process Streams Report</b>	
<b>All Streams</b>	
Tabulated by Total Phase	

Client Name:	DELAWARE DIVISION	Job:
Location:	Bulldog Compressor Station	
Flowsheet:	Output	

Connections					
-------------	--	--	--	--	--

	6. Skim Tank Flash Gas	7. Condensate Tank Flash Gas	8. Skim Tank W&B	9. Water Tank W&B	10. Condensate Tank W&B
From Block	Tankage - Gunbarrel Flash Gas	Tankage - Condensate Tank Flash Gas	W & B - Gunbarrel Tank	W & B - Water Tank	W & B - Condensate Tank
To Block	--	--	--	--	--

Stream Composition					
--------------------	--	--	--	--	--

	6. Skim Tank Flash Gas	7. Condensate Tank Flash Gas	8. Skim Tank W&B	9. Water Tank W&B	10. Condensate Tank W&B
Mass Flow	lb/h	Gas lb/h	lb/h	lb/h	lb/h
Triethylene Glycol	1.05113E-10	9.89993E-09	3.35172E-10	3.50942E-10	5.18578E-13
Water	0.0344037	0.685708	0.128969	0.128727	1.48305E-05
Hydrogen Sulfide	8.67221E-05	0.00376113	0.000328176	0.00033994	0.000156105
Carbon Dioxide	0.004085	0.101373	0.00808979	0.00583444	0.00415695
Nitrogen	0.000266502	0.00858354	1.25307E-05	9.23318E-06	2.02214E-05
Methane	0.0797425	4.02196	0.00905685	0.00566605	0.045702
Ethane	0.251762	24.3092	0.0896923	0.0265713	1.51883
Propane	0.678089	73.0639	0.673562	0.0503116	4.81968
Isobutane	0.22913	23.5242	0.572777	0.0118203	1.62503
n-Butane	0.654127	65.6254	2.39439	0.0442942	4.82784
Isopentane	0.225636	21.8774	0.858766	0.0107872	1.65793
n-Pentane	0.264221	25.4475	1.0121	0.00503188	1.93243
i-C6	0.215024	20.4322	0.834406	0.00561285	1.64047
i-C7	0.0886189	8.37174	0.34338	0.00158052	0.660169
Octane	0.0256788	2.42189	0.0981846	0.000103378	0.170885
Nonane	0.00414491	0.39021	0.0156978	1.70199E-05	0.0241421
Benzene	0.0106819	1.02405	0.041327	0.0409704	0.0530051
Toluene	0.00881074	0.835936	0.0339768	0.0338291	0.0446708
Ethylbenzene	0.000241112	0.0228023	0.000920905	0.000917679	0.00124543
o-Xylene	0.00216757	0.204988	0.00827137	0.00826299	0.00960647
n-Hexane	0.0902174	8.54749	0.349857	0.00116802	0.714413
2,2,4-Trimethylpentane	0	0	0	0	0
Decanes Plus	0.000168879	0.0159356	0.00062722	0.000139556	0.000862324
Decanes Plus Sat	0	0	0	0	0

	6. Skim Tank Flash Gas	7. Condensate Tank Flash Gas	8. Skim Tank W&B	9. Water Tank W&B	10. Condensate Tank W&B
Mole Fraction	%	Gas %	%	%	%
Triethylene Glycol	1.21388E-09	1.21739E-09	1.825E-09	1.95962E-08	9.5811E-13
Water	3.3119	0.70289	5.8537	59.9177	0.000228406
Hydrogen Sulfide	0.00441298	0.00203796	0.00787378	0.083641	0.00127086
Carbon Dioxide	0.160975	0.0425368	0.150306	1.11168	0.0262073
Nitrogen	0.0164986	0.00565835	0.000365759	0.00276384	0.000200281
Methane	8.62049	4.62974	0.461629	2.96167	0.79042
Ethane	14.5206	14.9293	2.43906	7.41005	14.0147
Propane	26.6688	30.5982	12.4902	9.56755	30.3261
Isobutane	6.83681	7.47414	8.05807	1.70535	7.75734
n-Butane	19.5179	20.8506	33.6853	6.39047	23.0465
Isopentane	5.42366	5.59959	9.73269	1.25374	6.37576
n-Pentane	6.35113	6.51335	11.4705	0.584829	7.43136
i-C6	4.32729	4.37845	7.91737	0.54617	5.28175
i-C7	1.53378	1.54287	2.80211	0.132267	1.82798
Octane	0.389864	0.391533	0.702839	0.00758893	0.41507
Nonane	0.0560471	0.056184	0.100081	0.00111278	0.052227
Benzene	0.237161	0.2421	0.432618	4.39827	0.188276
Toluene	0.165838	0.167541	0.301528	3.07877	0.134517

\* User Specified Values  
 ? Extrapolated or Approximate Values

<b>Process Streams Report</b>	
<b>All Streams</b>	
Tabulated by Total Phase	

Client Name:	DELAWARE DIVISION	Job:
Location:	Bulldog Compressor Station	
Flowsheet:	Output	

	6. Skim Tank Flash Gas	7. Condensate Tank Flash Gas	8. Skim Tank W&B	9. Water Tank W&B	10. Condensate Tank W&B
Mole Fraction	%	%	%	%	%
Ethylbenzene	0.00393867	0.0039663	0.00709285	0.0724832	0.00325484
o-Xylene	0.0354082	0.0356564	0.0637064	0.652655	0.0251059
n-Hexane	1.8156	1.83166	3.31967	0.113657	2.30017
2,2,4-Trimethylpentane	0	0	0	0	0
Decanes Plus	0.00190925	0.00191837	0.00334335	0.00762869	0.00155969
Decanes Plus Sat	0	0	0	0	0

	6. Skim Tank Flash Gas	7. Condensate Tank Flash Gas	8. Skim Tank W&B	9. Water Tank W&B	10. Condensate Tank W&B
Mass Fraction	%	%	%	%	%
Triethylene Glycol	3.66591E-09	3.52391E-09	4.48427E-09	9.1871E-08	2.62554E-12
Water	1.19986	0.24408	1.72547	33.6986	7.50861E-05
Hydrogen Sulfide	0.00302452	0.00133878	0.00439067	0.0889909	0.000790354
Carbon Dioxide	0.142468	0.036084	0.108233	1.52736	0.0210465
Nitrogen	0.00929453	0.00305533	0.000167648	0.0024171	0.00010238
Methane	2.7811	1.43163	0.121172	1.48328	0.231388
Ethane	8.78044	8.65291	1.19999	6.95594	7.68981
Propane	23.649	26.0073	9.01159	13.1708	24.4019
Isobutane	7.99114	8.37349	7.6632	3.09437	8.22747
n-Butane	22.8133	23.3595	32.0346	11.5955	24.4432
Isopentane	7.86928	7.78734	11.4894	2.82392	8.39407
n-Pentane	9.21497	9.05809	13.5409	1.31727	9.78383
i-C6	7.49916	7.27289	11.1635	1.46935	8.30562
i-C7	3.09067	2.97994	4.59408	0.413756	3.34241
Octane	0.895573	0.862078	1.31361	0.0270627	0.865182
Nonane	0.144558	0.138896	0.210021	0.00445554	0.122231
Benzene	0.37254	0.364514	0.552915	10.7254	0.268363
Toluene	0.307283	0.297554	0.454575	8.85591	0.226167
Ethylbenzene	0.00840901	0.00811653	0.0123208	0.240234	0.00630555
o-Xylene	0.0755961	0.0729662	0.110663	2.16312	0.0486372
n-Hexane	3.14642	3.0425	4.68074	0.305769	3.61705
2,2,4-Trimethylpentane	0	0	0	0	0
Decanes Plus	0.00588982	0.00567233	0.00839158	0.0365334	0.00436592
Decanes Plus Sat	0	0	0	0	0

Stream Properties						
Property	Units	6. Skim Tank Flash Gas	7. Condensate Tank Flash Gas	8. Skim Tank W&B	9. Water Tank W&B	10. Condensate Tank W&B
Temperature	°F	75.67	75.67	82.0362	82.6855	78.6044
Pressure	psig	0.5	0.25	-3.9673	-11.8056	0.0439129
Molecular Weight	lb/lbmol	49.7263	51.8796	61.1171	32.032	54.801
Mass Flow	lb/h	2.8673	280.936	7.4744	0.381994	19.7513
Std Vapor Volumetric Flow	MMSCFD	0.00052516	0.0493191	0.00111383	0.000108612	0.00328255
Std Liquid Volumetric Flow	sgpm	0.0106263	1.0366	0.024787	0.00111847	0.0714192
API Gravity						
Gross Ideal Gas Heating Value	Btu/ft <sup>3</sup>	2769.57	2915.86	3346.32	1149.83	3080.19

**Remarks**

\* User Specified Values  
 ? Extrapolated or Approximate Values

<b>Process Streams Report</b>	
<b>All Streams</b>	
Tabulated by Total Phase	

Client Name:	DELAWARE DIVISION	Job:
Location:	Bulldog Compressor Station	
Flowsheet:	Output	

Connections					
-------------	--	--	--	--	--

	11. Condensate Sales Liquid	12. Produced Water Liquid	13. BTEX Cond Vapors to Combustion	14. Skim Tank Inlet	15. HPF Pilot / Purge Gas
From Block	Tankage - Condensate Sales Liquid	Tankage - Produced Water Sales Liquid	Tankage - BTEX Vapors to Combustion	Tankage - Gunbarrel Tank Inlet	SPLT-100
To Block	--	--	--	--	--

Stream Composition					
--------------------	--	--	--	--	--

	11. Condensate Sales Liquid	12. Produced Water Liquid	13. BTEX Cond Vapors to Combustion	14. Skim Tank Inlet	15. HPF Pilot / Purge Gas
Mass Flow	lb/h	lb/h	lb/h	lb/h	lb/h
Triethylene Glycol	6.33307E-05	1.07682	3.11343E-08	1.07682	3.08322E-05
Water	0.170596	4975	1.46396	4975.04	0.00492918
Hydrogen Sulfide	0.00226551	0.000559356	0.119759	0.000680464	0.00218524
Carbon Dioxide	0.0208007	0.00862534	1.86983	0.0132616	0.359223
Nitrogen	0.00017029	1.36499E-05	0.01261	0.000283619	1.67839
Methane	0.29209	0.00837641	7.43021	0.0919205	81.1328
Ethane	11.4203	0.0392817	17.3237	0.36877	25.5877
Propane	122.333	0.0743783	30.0862	1.49888	17.6017
Isobutane	98.6614	0.0174746	5.29049	0.87855	2.84734
n-Butane	407.601	0.0654824	21.4663	3.3908	6.28916
Isopentane	335.495	0.0159473	8.37887	2.51756	1.43152
n-Pentane	518.971	0.00743889	11.5326	3.81717	1.48118
i-C6	1039	0.00829776	7.95601	7.41869	0.771116
i-C7	1347.49	0.00233657	2.33582	9.48463	0.181805
Octane	1840.94	0.000152829	0.242183	12.8911	0.0197729
Nonane	976.464	2.51614E-05	0.0121609	6.83122	0.000875601
Benzene	75.3806	0.149919	5.88284	0.679596	0.0161184
Toluene	214.168	0.0925825	2.92114	1.59148	0.00821242
Ethylbenzene	18.3062	0.00225858	0.0270334	0.130307	0.000128558
o-Xylene	203.647	0.0301824	0.282454	1.454	0.000863606
n-Hexane	632.092	0.00172674	3.23896	4.48253	0.271595
2,2,4-Trimethylpentane	0	0	0	0	0
Decanes Plus	263.639	0.000206312	0.000157435	1.84393	3.52739E-06
Decanes Plus Sat	0	0	0	0	0

	11. Condensate Sales Liquid	12. Produced Water Liquid	13. BTEX Cond Vapors to Combustion	14. Skim Tank Inlet	15. HPF Pilot / Purge Gas
Mole Fraction	%	%	%	%	%
Triethylene Glycol	4.82495E-07	0.00259642	7.27194E-09	0.00259024	3.11649E-06
Water	0.0108342	99.9942	2.8503	99.7571	0.00415324
Hydrogen Sulfide	7.60547E-05	5.94292E-06	0.123254	7.21244E-06	0.000973289
Carbon Dioxide	0.000540756	7.09664E-05	1.49025	0.000108853	0.1239
Nitrogen	6.95492E-06	1.76435E-07	0.0157889	3.65727E-06	0.909452
Methane	0.0208313	0.000189064	16.2455	0.0020698	76.7678
Ethane	0.434539	0.000473035	20.2081	0.00443021	12.9171
Propane	3.17407	0.000610764	23.9318	0.0122789	6.05916
Isobutane	1.94212	0.000108865	3.19269	0.00546025	0.743618
n-Butane	8.02349	0.000407948	12.9544	0.021074	1.64249
Isopentane	5.32019	8.0035E-05	4.07342	0.0126049	0.301176
n-Pentane	8.2297	3.73337E-05	5.60661	0.0191118	0.311625
i-C6	13.7944	3.48659E-05	3.23829	0.031098	0.135828
i-C7	15.3858	8.44354E-06	0.817649	0.0341926	0.0275413
Octane	18.4389	4.84455E-07	0.0743657	0.0407663	0.00262754

\* User Specified Values  
 ? Extrapolated or Approximate Values

## Process Streams Report All Streams Tabulated by Total Phase

Client Name:	DELAWARE DIVISION	Job:
Location:	Bulldog Compressor Station	
Flowsheet:	Output	

	11. Condensate Sales Liquid	12. Produced Water Liquid	13. BTEX Cond Vapors to Combustion	14. Skim Tank Inlet	15. HPF Pilot / Purge Gas
Mole Fraction	%	%	%	%	%
Nonane	8.71067	7.10367E-08	0.00332577	0.0192403	0.00010363
Benzene	1.10411	0.000694964	2.64164	0.00314284	0.00313226
Toluene	2.6594	0.00036384	1.11203	0.00623948	0.00135296
Ethylbenzene	0.197281	7.70328E-06	0.00893145	0.000443378	1.83811E-05
o-Xylene	2.19465	0.000102942	0.093319	0.00494735	0.000123477
n-Hexane	8.39203	7.25549E-06	1.31833	0.0187901	0.0478401
2,2,4-Trimethylpentane	0	0	0	0	0
Decanes Plus	1.96632	4.86992E-07	3.5998E-05	0.00434218	3.49045E-07
Decanes Plus Sat	0	0	0	0	0

	11. Condensate Sales Liquid	12. Produced Water Liquid	13. BTEX Cond Vapors to Combustion	14. Skim Tank Inlet	15. HPF Pilot / Purge Gas
Mass Fraction	%	%	%	%	%
Triethylene Glycol	7.81272E-07	0.0216377	2.43478E-08	0.0213846	2.20724E-05
Water	0.00210454	99.9678	1.14485	98.7993	0.00352874
Hydrogen Sulfide	2.79483E-05	1.12397E-05	0.0936543	1.35133E-05	0.00156439
Carbon Dioxide	0.000256606	0.000173318	1.46225	0.000263363	0.257163
Nitrogen	2.10076E-06	2.74281E-07	0.00986132	5.63239E-06	1.20154
Methane	0.00360334	0.000168316	5.8106	0.00182545	58.082
Ethane	0.140886	0.000789328	13.5476	0.0073234	18.3179
Propane	1.50914	0.00149456	23.5281	0.0297662	12.6008
Isobutane	1.21713	0.000351134	4.13729	0.0174471	2.03837
n-Butane	5.02833	0.00131581	16.7872	0.0673378	4.50233
Isopentane	4.1388	0.000320445	6.55248	0.0499962	1.0248
n-Pentane	6.40223	0.000149477	9.01875	0.0758052	1.06036
i-C6	12.8175	0.000166736	6.2218	0.147328	0.552033
i-C7	16.6232	4.6951E-05	1.82667	0.188355	0.130152
Octane	22.7106	3.07095E-06	0.189393	0.256003	0.0141552
Nonane	12.046	5.05594E-07	0.00951008	0.135661	0.000626833
Benzene	0.929925	0.00301248	4.60052	0.0134961	0.011539
Toluene	2.64206	0.00186036	2.2844	0.0316052	0.00587918
Ethylbenzene	0.225832	4.53839E-05	0.0211408	0.00258776	9.2033E-05
o-Xylene	2.51226	0.000606485	0.220886	0.0288751	0.000618245
n-Hexane	7.79773	3.46972E-05	2.53294	0.0890185	0.194432
2,2,4-Trimethylpentane	0	0	0	0	0
Decanes Plus	3.25235	4.14564E-06	0.000123118	0.0366186	2.52522E-06
Decanes Plus Sat	0	0	0	0	0

### Stream Properties

Property	Units	11. Condensate Sales Liquid	12. Produced Water Liquid	13. BTEX Cond Vapors to Combustion	14. Skim Tank Inlet	15. HPF Pilot / Purge Gas
Temperature	°F	75.67	75.8095	70	75.7	76.5751
Pressure	psig	0.25	0.25	0	15	120
Molecular Weight	lb/lbmol	92.7432	18.02	44.8521	18.1899	21.2035
Mass Flow	lb/h	8106.1	4976.6	127.873	5035.5	139.687
Std Vapor Volumetric Flow	MMSCFD	0.79604	2.51525	0.0259658	2.52125	0.06 *
Std Liquid Volumetric Flow	sgpm	23.7476	9.94891	0.49092	10.1234	0.8036
API Gravity		73.9665	9.99586		10.7657	
Gross Ideal Gas Heating Value	Btu/ft <sup>3</sup>	5054.3	50.5119	2460.05	61.9959	1269.3

**Remarks**

\* User Specified Values  
? Extrapolated or Approximate Values

		<b>Process Streams Report</b> <b>All Streams</b> Tabulated by Total Phase		
Client Name:	DELAWARE DIVISION	Job:		
Location:	Bulldog Compressor Station			
Flowsheet:	Output			

	<b>Process Streams Report</b> <b>All Streams</b> Tabulated by Total Phase	
--	---	--

Client Name:	DELAWARE DIVISION	Job:
Location:	Bulldog Compressor Station	
Flowsheet:	Output	

Connections					
-------------	--	--	--	--	--

	16. LPF Pilot / Purge Gas	17. HPF Blowdowns	18. Fuel Gas Other	19. Inlet Flaring	20. Fuel Gas Other
From Block	SPLT-100	SPLT-100	SPLT-100	SPLT-101	SPLT-101
To Block	--	--	--	--	--

Stream Composition					
--------------------	--	--	--	--	--

Mass Flow	16. LPF Pilot / Purge Gas lb/h	17. HPF Blowdowns lb/h	18. Fuel Gas Other lb/h	19. Inlet Flaring lb/h	20. Fuel Gas Other lb/h
Triethylene Glycol	1.61869E-05	1.17356E-05	0.00653115	0.984264	2.24134
Water	0.00258782	0.00187618	1.04414	5.61692	12.7907
Hydrogen Sulfide	0.00114725	0.000831763	0.462897	2.59011	5.89814
Carbon Dioxide	0.188592	0.13673	76.0938	411.007	935.936
Nitrogen	0.881154	0.638841	355.531	1874.31	4268.12
Methane	42.5947	30.8814	17186.3	91413.2	208164
Ethane	13.4335	9.73938	5420.2	30115.6	68578.4
Propane	9.24089	6.6997	3728.54	22642.9	51561.8
Isobutane	1.49485	1.08378	603.147	4178.6	9515.41
n-Butane	3.30181	2.39383	1332.22	10051.9	22889.9
Isopentane	0.751546	0.544875	303.236	2947.97	6713.05
n-Pentane	0.777619	0.563778	313.756	3381.48	7700.23
i-C6	0.404836	0.293508	163.345	2735.89	6230.11
i-C7	0.0954478	0.0692002	38.5116	1239.87	2823.41
Octane	0.0103808	0.00752611	4.18846	373.938	851.523
Nonane	0.000459691	0.000333278	0.185478	46.1555	105.104
Benzene	0.00846215	0.00613511	3.41434	63.972	145.675
Toluene	0.00431152	0.00312588	1.73963	71.1383	161.994
Ethylbenzene	6.74929E-05	4.89327E-05	0.0272322	2.48051	5.64856
o-Xylene	0.000453393	0.000328713	0.182937	19.9589	45.4499
n-Hexane	0.142587	0.103377	57.5316	1194.79	2720.74
2,2,4-Trimethylpentane	0	0	0	0	0
Decanes Plus	1.85188E-06	1.34262E-06	0.000747203	0.676627	1.5408
Decanes Plus Sat	0	0	0	0	0

Mole Fraction	16. LPF Pilot / Purge Gas %	17. HPF Blowdowns %	18. Fuel Gas Other %	19. Inlet Flaring %	20. Fuel Gas Other %
Triethylene Glycol	3.11649E-06	3.11649E-06	3.11649E-06	8.52759E-05	8.52759E-05
Water	0.00415324	0.00415324	0.00415324	0.00405662	0.00405662
Hydrogen Sulfide	0.000973289	0.000973289	0.000973289	0.000988813	0.000988813
Carbon Dioxide	0.1239	0.1239	0.1239	0.121509	0.121509
Nitrogen	0.909452	0.909452	0.909452	0.870525	0.870525
Methane	76.7678	76.7678	76.7678	74.1386	74.1386
Ethane	12.9171	12.9171	12.9171	13.031	13.031
Propane	6.05916	6.05916	6.05916	6.68101	6.68101
Isobutane	0.743618	0.743618	0.743618	0.935396	0.935396
n-Butane	1.64249	1.64249	1.64249	2.25015	2.25015
Isopentane	0.301176	0.301176	0.301176	0.53162	0.53162
n-Pentane	0.311625	0.311625	0.311625	0.609797	0.609797
i-C6	0.135828	0.135828	0.135828	0.413069	0.413069
i-C7	0.0275413	0.0275413	0.0275413	0.160993	0.160993
Octane	0.00262754	0.00262754	0.00262754	0.0425924	0.0425924
Nonane	0.00010363	0.00010363	0.00010363	0.00468226	0.00468226
Benzene	0.00313226	0.00313226	0.00313226	0.0106556	0.0106556
Toluene	0.00135296	0.00135296	0.00135296	0.0100455	0.0100455
Ethylbenzene	1.83811E-05	1.83811E-05	1.83811E-05	0.000303995	0.000303995
o-Xylene	0.000123477	0.000123477	0.000123477	0.00244603	0.00244603
n-Hexane	0.0478401	0.0478401	0.0478401	0.180391	0.180391
2,2,4-Trimethylpentane	0	0	0	0	0
Decanes Plus	3.49045E-07	3.49045E-07	3.49045E-07	5.73892E-05	5.73892E-05
Decanes Plus Sat	0	0	0	0	0

\* User Specified Values  
 ? Extrapolated or Approximate Values

**Process Streams Report**  
**All Streams**  
 Tabulated by Total Phase

Client Name:	DELAWARE DIVISION	Job:
Location:	Bulldog Compressor Station	
Flowsheet:	Output	

Mass Fraction	16. LPF Pilot / Purge Gas %	17. HPF Blowdowns %	18. Fuel Gas Other %	19. Inlet Flaring %	20. Fuel Gas Other %
Triethylene Glycol	2.20724E-05	2.20724E-05	2.20724E-05	0.00056968	0.00056968
Water	0.00352874	0.00352874	0.00352874	0.003251	0.003251
Hydrogen Sulfide	0.00156439	0.00156439	0.00156439	0.00149912	0.00149912
Carbon Dioxide	0.257163	0.257163	0.257163	0.237886	0.237886
Nitrogen	1.20154	1.20154	1.20154	1.08483	1.08483
Methane	58.082	58.082	58.082	52.9088	52.9088
Ethane	18.3179	18.3179	18.3179	17.4305	17.4305
Propane	12.6008	12.6008	12.6008	13.1054	13.1054
Isobutane	2.03837	2.03837	2.03837	2.41852	2.41852
n-Butane	4.50233	4.50233	4.50233	5.8179	5.8179
Isopentane	1.0248	1.0248	1.0248	1.70625	1.70625
n-Pentane	1.06036	1.06036	1.06036	1.95716	1.95716
i-C6	0.552033	0.552033	0.552033	1.5835	1.5835
i-C7	0.130152	0.130152	0.130152	0.717624	0.717624
Octane	0.0141552	0.0141552	0.0141552	0.216431	0.216431
Nonane	0.000626833	0.000626833	0.000626833	0.0267142	0.0267142
Benzene	0.011539	0.011539	0.011539	0.0370262	0.0370262
Toluene	0.00587918	0.00587918	0.00587918	0.041174	0.041174
Ethylbenzene	9.2033E-05	9.2033E-05	9.2033E-05	0.00143569	0.00143569
o-Xylene	0.000618245	0.000618245	0.000618245	0.011552	0.011552
n-Hexane	0.194432	0.194432	0.194432	0.691528	0.691528
2,2,4-Trimethylpentane	0	0	0	0	0
Decanes Plus	2.52522E-06	2.52522E-06	2.52522E-06	0.000391623	0.000391623
Decanes Plus Sat	0	0	0	0	0

**Stream Properties**

Property	Units	16. LPF Pilot / Purge Gas	17. HPF Blowdowns	18. Fuel Gas Other	19. Inlet Flaring	20. Fuel Gas Other
Temperature	°F	76.5751	76.5751	76.5751	93.2634	93.2634
Pressure	psig	120	120	120	1272	1272
Molecular Weight	lb/lbmol	21.2035	21.2035	21.2035	22.4795	22.4795
Mass Flow	lb/h	73.3355	53.1686	29589.6	172775	393439
Std Vapor Volumetric Flow	MMSCFD	0.0315 *	0.0228377 *	12.7097	70 *	159.402
Std Liquid Volumetric Flow	sgpm	0.42189	0.305873	170.226	959.779	2185.59
API Gravity						
Gross Ideal Gas Heating Value	Btu/ft <sup>3</sup>	1269.3	1269.3	1269.3	1338.01	1338.01

**Remarks**



<b>Process Streams Report</b>	
<b>All Streams</b>	
Tabulated by Total Phase	

Client Name:	DELAWARE DIVISION	Job:
Location:	Bulldog Compressor Station	
Flowsheet:	Output	

<b>Connections</b>					
--------------------	--	--	--	--	--

	21. Inlet Gas	22. Condensate Flash Losses Hrly	23. HPS Water to SWD	24. VC1 Pilot Fuel	
From Block	Inlet - Inlet Gas	W & B - Cond Flashing Losses Hrly	Inlet - HPS water	SPLT-100	
To Block	--	--	--	--	

<b>Stream Composition</b>					
---------------------------	--	--	--	--	--

	21. Inlet Gas	22. Condensate Flash Losses Hrly	23. HPS Water to SWD	24. VC1 Pilot Fuel	
Mass Flow	lb/h	lb/h	lb/h	lb/h	
Triethylene Glycol	0	1.05542E-11	6.32885E-05	1.47995E-05	
Water	0	0.000371915	1350.9	0.00236601	
Hydrogen Sulfide	8.98948	0.00504789	0.000733058	0.00104892	
Carbon Dioxide	1404.61	0.114158	0.0419495	0.172427	
Nitrogen	6384.15	0.000752227	0.00410197	0.805626	
Methane	311574	1.26894	0.513033	38.9438	
Ethane	103011	42.3671	0.199228	12.2821	
Propane	77974.6	144.696	0.0815392	8.44881	
Isobutane	14549	48.413	0.00802087	1.36672	
n-Butane	35306.9	152.628	0.0276614	3.0188	
Isopentane	10676.2	50.5162	0.00443203	0.687127	
n-Pentane	12446	60.1251	0.00235678	0.710966	
i-C6	10956	24.3019	0.00211499	0.370136	
i-C7	6078.94	26.5986	0.000458523	0.0872666	
Octane	3344.42	4.91654	3.44751E-05	0.00949098	
Nonane	1082.55	0.543479	3.89191E-06	0.000420289	
Benzene	309.052	1.83996	0.027322	0.00773682	
Toluene	486.065	1.52189	0.0178629	0.00394196	
Ethylbenzene	28.003	0.044416	0.00040446	6.17077E-05	
o-Xylene	280.03	0.300355	0.00538719	0.000414531	
n-Hexane	5023.42	17.2603	0.000445207	0.130366	
2,2,4-Trimethylpentane	0	1.06002	0	0	
Decanes Plus	202.311	0.000358566	3.05808E-05	1.69315E-06	
Decanes Plus Sat	0	0	0	0	

	21. Inlet Gas	22. Condensate Flash Losses Hrly	23. HPS Water to SWD	24. VC1 Pilot Fuel	
Mole Fraction	%	%	%	%	
Triethylene Glycol	0	6.62247E-13	5.61696E-07	3.11649E-06	
Water	0	0.000194532	99.9428	0.00415324	
Hydrogen Sulfide	0.00100096	0.00139568	2.86679E-05	0.000973289	
Carbon Dioxide	0.121116	0.0244426	0.00127042	0.1239	
Nitrogen	0.86483	0.000253029	0.000195162	0.909452	
Methane	73.7028	0.745348	0.0426229	76.7678	
Ethane	13.0005	13.2769	0.00883077	12.9171	
Propane	6.71044	30.9207	0.00246456	6.05916	
Isobutane	0.949912	7.84887	0.000183928	0.743618	
n-Butane	2.30521	24.7445	0.000634307	1.64249	
Isopentane	0.561539	6.59765	8.18732E-05	0.301176	
n-Pentane	0.654628	7.85262	4.3537E-05	0.311625	
i-C6	0.482463	2.65732	3.27109E-05	0.135828	
i-C7	0.230221	2.50133	6.09893E-06	0.0275413	
Octane	0.111107	0.405576	4.02253E-07	0.00262754	
Nonane	0.0320307	0.0399297	4.04442E-08	0.00010363	

\* User Specified Values  
 ? Extrapolated or Approximate Values

## Process Streams Report

### All Streams

Tabulated by Total Phase

Client Name:	DELAWARE DIVISION	Job:
Location:	Bulldog Compressor Station	
Flowsheet:	Output	

	21. Inlet Gas	22. Condensate Flash Losses Hrly	23. HPS Water to SWD	24. VC1 Pilot Fuel	
Mole Fraction	%	%	%	%	
Benzene	0.0150144	0.221963	0.000466191	0.00313226	
Toluene	0.0200192	0.155643	0.000258392	0.00135296	
Ethylbenzene	0.00100096	0.00394226	5.07764E-06	1.83811E-05	
o-Xylene	0.0100096	0.0266588	6.76316E-05	0.000123477	
n-Hexane	0.221212	1.88736	6.88568E-06	0.0478401	
2,2,4-Trimethylpentane	0	0.0874435	0	0	
Decanes Plus	0.0050048	2.20258E-05	2.657E-07	3.49045E-07	
Decanes Plus Sat	0	0	0	0	

	21. Inlet Gas	22. Condensate Flash Losses Hrly	23. HPS Water to SWD	24. VC1 Pilot Fuel	
Mass Fraction	%	%	%	%	
Triethylene Glycol	0	1.82433E-12	4.68165E-06	2.20724E-05	
Water	0	6.42871E-05	99.9307	0.00352874	
Hydrogen Sulfide	0.00149544	0.00087255	5.42267E-05	0.00156439	
Carbon Dioxide	0.233663	0.0197327	0.00310314	0.257163	
Nitrogen	1.06203	0.000130026	0.000303436	1.20154	
Methane	51.8317	0.219342	0.0379507	58.082	
Ethane	17.1364	7.32333	0.0147375	18.3179	
Propane	12.9714	25.0113	0.00603172	12.6008	
Isobutane	2.42028	8.36839	0.00059333	2.03837	
n-Butane	5.87345	26.3823	0.0020462	4.50233	
Isopentane	1.77603	8.73194	0.000327851	1.0248	
n-Pentane	2.07045	10.3929	0.000174339	1.06036	
i-C6	1.82259	4.20068	0.000156452	0.552033	
i-C7	1.01126	4.59769	3.39184E-05	0.130152	
Octane	0.556359	0.849845	2.55023E-06	0.0141552	
Nonane	0.180087	0.0939427	2.87897E-07	0.000626833	
Benzene	0.0514122	0.318045	0.0020211	0.011539	
Toluene	0.080859	0.263065	0.00132138	0.00587918	
Ethylbenzene	0.00465842	0.00767749	2.99192E-05	9.2033E-05	
o-Xylene	0.0465842	0.0519176	0.000398508	0.000618245	
n-Hexane	0.835667	2.98352	3.29334E-05	0.194432	
2,2,4-Trimethylpentane	0	0.183229	0	0	
Decanes Plus	0.0336553	6.19796E-05	2.26216E-06	2.52522E-06	
Decanes Plus Sat	0	0	0	0	

### Stream Properties

Property	Units	21. Inlet Gas	22. Condensate Flash Losses Hrly	23. HPS Water to SWD	24. VC1 Pilot Fuel	
Temperature	°F	110	92.65	94.2513	76.5751	
Pressure	psig	124	6.06136	400	120	
Molecular Weight	lb/lbmol	22.8118	54.5139	18.0175	21.2035	
Mass Flow	lb/h	601127	578.522	1351.84	67.0496	
Std Vapor Volumetric Flow	MMSCFD	240	0.0966534	0.683339	0.0288 *	
Std Liquid Volumetric Flow	sgpm	3309.52	2.09364	2.7058	0.385728	
API Gravity				10.0439		
Gross Ideal Gas Heating Value	Btu/ft^3	1355.71	3064.41	50.997	1269.3	

**Remarks**

\* User Specified Values  
 ? Extrapolated or Approximate Values

<b>User Value Sets Report</b>		
Client Name:	DELAWARE DIVISION	Job:
Location:	Bulldog Compressor Station	
<b>Skim Tank</b>		
<b>User Value [BlockReady]</b>		
* Parameter	1	* Enforce Bounds False
<b>User Value [ShellLength]</b>		
* Parameter	30 ft	* Enforce Bounds False
<b>User Value [ShellDiam]</b>		
* Parameter	15.5 ft	* Enforce Bounds False
<b>User Value [BreatherVP]</b>		
* Parameter	0.03 psig	* Enforce Bounds False
<b>User Value [BreatherVacP]</b>		
* Parameter	-0.03 psig	* Enforce Bounds False
<b>User Value [DomeRadius]</b>		
* Enforce Bounds	False	
<b>User Value [OpPress]</b>		
* Parameter	0.25 psig	* Enforce Bounds False
<b>User Value [AvgPercentLiq]</b>		
* Parameter	80 %	* Enforce Bounds False
<b>User Value [MaxPercentLiq]</b>		
* Parameter	90 %	* Enforce Bounds False
<b>User Value [MinPercentLiq]</b>		
* Parameter	10 %	* Enforce Bounds False
<b>User Value [AnnNetTP]</b>		
* Parameter	347.202 bbl/day	* Enforce Bounds False
<b>User Value [OREff]</b>		
* Enforce Bounds	False	
<b>User Value [MaxAvgT]</b>		
* Parameter	75.8 °F	* Enforce Bounds False
<b>User Value [MinAvgT]</b>		
* Parameter	47.6 °F	* Enforce Bounds False
<b>User Value [BulkLiqT]</b>		
* Parameter	75.6428 °F	* Enforce Bounds False
<b>User Value [AvgP]</b>		
* Parameter	12.88 psia	* Enforce Bounds False
<b>User Value [ThermI]</b>		
* Parameter	1722 Btu/ft <sup>2</sup> /day	* Enforce Bounds False

\* User Specified Values  
 ? Extrapolated or Approximate Values

ProMax 5.0.19050.0  
 Copyright © 2002-2019 BRE Group, Ltd.

Licensed to Esso Exploration, Inc.

## User Value Sets Report

Client Name:	DELAWARE DIVISION	Job:
Location:	Bulldog Compressor Station	

### User Value [AvgWindSpeed]

* Parameter	8.7 mi/h	* Enforce Bounds	False
-------------	----------	------------------	-------

### User Value [MaxHourlyLoadingRate]

* Enforce Bounds	False		
------------------	-------	--	--

### User Value [SumLiqLevelInc]

* Enforce Bounds	False		
------------------	-------	--	--

### User Value [FlashingT]

* Parameter	82.0362 °F	* Enforce Bounds	False
-------------	------------	------------------	-------

### User Value [EntrainedOilFrac]

* Parameter	1 %	* Enforce Bounds	False
-------------	-----	------------------	-------

### User Value [TurnoverRate]

* Parameter	78.5512	* Enforce Bounds	False
-------------	---------	------------------	-------

### User Value [LLossSatFactor]

* Enforce Bounds	False		
------------------	-------	--	--

### User Value [AtmPressure]

* Parameter	12.88 psia	* Enforce Bounds	False
-------------	------------	------------------	-------

### User Value [TVP]

* Parameter	11.1351 psia	* Enforce Bounds	False
-------------	--------------	------------------	-------

### User Value [MaxVP]

* Parameter	12.88 psia	* Enforce Bounds	False
-------------	------------	------------------	-------

### User Value [MinVP]

* Parameter	9.59201 psia	* Enforce Bounds	False
-------------	--------------	------------------	-------

### User Value [AvgLiqSurfaceT]

* Parameter	72.7396 °F	* Enforce Bounds	False
-------------	------------	------------------	-------

### User Value [MaxLiqSurfaceT]

* Parameter	82.0362 °F	* Enforce Bounds	False
-------------	------------	------------------	-------

### User Value [TotalLosses]

* Parameter	31.7035 ton/yr	* Enforce Bounds	False
-------------	----------------	------------------	-------

### User Value [WorkingLosses]

* Parameter	12.6077 ton/yr	* Enforce Bounds	False
-------------	----------------	------------------	-------

### User Value [StandingLosses]

* Parameter	3.24402 ton/yr	* Enforce Bounds	False
-------------	----------------	------------------	-------

### User Value [RimSealLosses]

* Parameter	0 ton/yr	* Enforce Bounds	False
-------------	----------	------------------	-------

### User Value [WithdrawalLoss]

* Parameter	0 ton/yr	* Enforce Bounds	False
-------------	----------	------------------	-------

\* User Specified Values  
? Extrapolated or Approximate Values

ProMax 5.0.19050.0  
Copyright © 2002-2019 BRE Group, Ltd.

Licensed to Esso Exploration, Inc.

## User Value Sets Report

Client Name:	DELAWARE DIVISION	Job:
Location:	Bulldog Compressor Station	

### User Value [LoadingLosses]

* Parameter	0 ton/yr	* Enforce Bounds	False
-------------	----------	------------------	-------

### User Value [MaxHourlyLoadingLoss]

* Parameter	0 lb/hr	* Enforce Bounds	False
-------------	---------	------------------	-------

### User Value [PStar]

* Enforce Bounds	False
------------------	-------

### User Value [AllCTotalLosses]

* Parameter	32.7379 ton/yr	* Enforce Bounds	False
-------------	----------------	------------------	-------

### User Value [AllCLoadingLosses]

* Parameter	0 ton/yr	* Enforce Bounds	False
-------------	----------	------------------	-------

### User Value [AllCMaxHLoadingLoss]

* Parameter	0 lb/hr	* Enforce Bounds	False
-------------	---------	------------------	-------

### User Value [AllCFlashingLosses]

* Parameter	17.0612 ton/yr	* Enforce Bounds	False
-------------	----------------	------------------	-------

### User Value [DeckFittingLosses]

* Parameter	0 ton/yr	* Enforce Bounds	False
-------------	----------	------------------	-------

### User Value [DeckSeamLosses]

* Parameter	0 ton/yr	* Enforce Bounds	False
-------------	----------	------------------	-------

### User Value [FlashingLosses]

* Parameter	15.2029 ton/yr	* Enforce Bounds	False
-------------	----------------	------------------	-------

### User Value [TotalResidual]

* Parameter	22005.7 ton/yr	* Enforce Bounds	False
-------------	----------------	------------------	-------

### User Value [GasMoleWeight]

* Parameter	0.0510921 kg/mol	* Enforce Bounds	False
-------------	------------------	------------------	-------

### User Value [VapReportableFrac]

* Parameter	96.8406 %	* Enforce Bounds	False
-------------	-----------	------------------	-------

### User Value [LiqReportableFrac]

* Parameter	1.12322 %	* Enforce Bounds	False
-------------	-----------	------------------	-------

### User Value [FlashReportableFrac]

* Parameter	89.108 %	* Enforce Bounds	False
-------------	----------	------------------	-------

#### Remarks

This User Value Set was programmatically generated. GUID={60FADE6C-8D03-40FF-A704-07DD6E91075D}

### Condensate Tank

#### User Value [BlockReady]

* Parameter	1	* Enforce Bounds	False
-------------	---	------------------	-------

\* User Specified Values

? Extrapolated or Approximate Values

ProMax 5.0.19050.0

Copyright © 2002-2019 BRE Group, Ltd.

Licensed to Esso Exploration, Inc.

## User Value Sets Report

Client Name:	DELAWARE DIVISION	Job:
Location:	Bulldog Compressor Station	

### User Value [ShellLength]

* Parameter	16 ft	* Enforce Bounds	False
-------------	-------	------------------	-------

### User Value [ShellDiam]

* Parameter	15.5 ft	* Enforce Bounds	False
-------------	---------	------------------	-------

### User Value [BreatherVP]

* Parameter	0.03 psig	* Enforce Bounds	False
-------------	-----------	------------------	-------

### User Value [BreatherVacP]

* Parameter	-0.03 psig	* Enforce Bounds	False
-------------	------------	------------------	-------

### User Value [DomeRadius]

* Enforce Bounds	False		
------------------	-------	--	--

### User Value [OpPress]

* Parameter	0.25 psig	* Enforce Bounds	False
-------------	-----------	------------------	-------

### User Value [AvgPercentLiq]

* Parameter	50 %	* Enforce Bounds	False
-------------	------	------------------	-------

### User Value [MaxPercentLiq]

* Parameter	90 %	* Enforce Bounds	False
-------------	------	------------------	-------

### User Value [MinPercentLiq]

* Parameter	10 %	* Enforce Bounds	False
-------------	------	------------------	-------

### User Value [AnnNetTP]

* Parameter	778.81 bbl/day	* Enforce Bounds	False
-------------	----------------	------------------	-------

### User Value [OREff]

* Parameter	0 %	* Enforce Bounds	False
-------------	-----	------------------	-------

### User Value [MaxAvgT]

* Parameter	75.8 °F	* Enforce Bounds	False
-------------	---------	------------------	-------

### User Value [MinAvgT]

* Parameter	47.6 °F	* Enforce Bounds	False
-------------	---------	------------------	-------

### User Value [BulkLiqT]

* Parameter	68.8214 °F	* Enforce Bounds	False
-------------	------------	------------------	-------

### User Value [AvgP]

* Parameter	12.88 psia	* Enforce Bounds	False
-------------	------------	------------------	-------

### User Value [ThermI]

* Parameter	1722 Btu/ft <sup>2</sup> /day	* Enforce Bounds	False
-------------	-------------------------------	------------------	-------

### User Value [AvgWindSpeed]

* Parameter	8.7 mi/h	* Enforce Bounds	False
-------------	----------	------------------	-------

## User Value Sets Report

Client Name:	DELAWARE DIVISION	Job:
Location:	Bulldog Compressor Station	

### User Value [MaxHourlyLoadingRate]

* Parameter	210 bbl/hr	* Enforce Bounds	False
-------------	------------	------------------	-------

### User Value [SumLiqLevelInc]

* Enforce Bounds	False		
------------------	-------	--	--

### User Value [FlashingT]

* Parameter	92.65 °F	* Enforce Bounds	False
-------------	----------	------------------	-------

### User Value [EntrainedOilFrac]

* Parameter	1 %	* Enforce Bounds	False
-------------	-----	------------------	-------

### User Value [TurnoverRate]

* Parameter	165.186	* Enforce Bounds	False
-------------	---------	------------------	-------

### User Value [LLossSatFactor]

* Parameter	0.6	* Enforce Bounds	False
-------------	-----	------------------	-------

### User Value [AtmPressure]

* Parameter	12.88 psia	* Enforce Bounds	False
-------------	------------	------------------	-------

### User Value [TVP]

* Parameter	9.13802 psia	* Enforce Bounds	False
-------------	--------------	------------------	-------

### User Value [MaxVP]

* Parameter	10.6294 psia	* Enforce Bounds	False
-------------	--------------	------------------	-------

### User Value [MinVP]

* Parameter	7.82126 psia	* Enforce Bounds	False
-------------	--------------	------------------	-------

### User Value [AvgLiqSurfaceT]

* Parameter	69.4251 °F	* Enforce Bounds	False
-------------	------------	------------------	-------

### User Value [MaxLiqSurfaceT]

* Parameter	78.6044 °F	* Enforce Bounds	False
-------------	------------	------------------	-------

### User Value [TotalLosses]

* Parameter	79.6388 ton/yr	* Enforce Bounds	False
-------------	----------------	------------------	-------

### User Value [WorkingLosses]

* Parameter	16.2044 ton/yr	* Enforce Bounds	False
-------------	----------------	------------------	-------

### User Value [StandingLosses]

* Parameter	3.7053 ton/yr	* Enforce Bounds	False
-------------	---------------	------------------	-------

### User Value [RimSealLosses]

* Parameter	0 ton/yr	* Enforce Bounds	False
-------------	----------	------------------	-------

### User Value [WithdrawalLoss]

* Parameter	0 ton/yr	* Enforce Bounds	False
-------------	----------	------------------	-------

### User Value [LoadingLosses]

* Parameter	38.8844 ton/yr	* Enforce Bounds	False
-------------	----------------	------------------	-------

\* User Specified Values  
? Extrapolated or Approximate Values

ProMax 5.0.19050.0  
Copyright © 2002-2019 BRE Group, Ltd.

Licensed to Esso Exploration, Inc.

## User Value Sets Report

Client Name:	DELAWARE DIVISION	Job:
Location:	Bulldog Compressor Station	

### User Value [MaxHourlyLoadingLoss]

* Parameter	57.4514 lb/hr	* Enforce Bounds	False
-------------	---------------	------------------	-------

### User Value [PStar]

* Enforce Bounds	False		
------------------	-------	--	--

### User Value [AllCTotalLosses]

* Parameter	86.5106 ton/yr	* Enforce Bounds	False
-------------	----------------	------------------	-------

### User Value [AllCLoadingLosses]

* Parameter	42.2396 ton/yr	* Enforce Bounds	False
-------------	----------------	------------------	-------

### User Value [AllCMaxHLoadingLoss]

* Parameter	62.4086 lb/hr	* Enforce Bounds	False
-------------	---------------	------------------	-------

### User Value [AllCFlashingLosses]

* Parameter	2533.93 ton/yr	* Enforce Bounds	False
-------------	----------------	------------------	-------

### User Value [DeckFittingLosses]

* Parameter	0 ton/yr	* Enforce Bounds	False
-------------	----------	------------------	-------

### User Value [DeckSeamLosses]

* Parameter	0 ton/yr	* Enforce Bounds	False
-------------	----------	------------------	-------

### User Value [FlashingLosses]

* Parameter	2381.84 ton/yr	* Enforce Bounds	False
-------------	----------------	------------------	-------

### User Value [TotalResidual]

* Parameter	34114.8 ton/yr	* Enforce Bounds	False
-------------	----------------	------------------	-------

### User Value [GasMoleWeight]

* Parameter	0.054801 kg/mol	* Enforce Bounds	False
-------------	-----------------	------------------	-------

### User Value [VapReportableFrac]

* Parameter	92.0568 %	* Enforce Bounds	False
-------------	-----------	------------------	-------

### User Value [LiqReportableFrac]

* Parameter	99.9191 %	* Enforce Bounds	False
-------------	-----------	------------------	-------

### User Value [FlashReportableFrac]

* Parameter	93.998 %	* Enforce Bounds	False
-------------	----------	------------------	-------

#### Remarks

This User Value Set was programmatically generated. GUID={AE1B16B2-2B8A-47A4-8AEF-7E4BCD819B7B}

### Produced Water Tank

#### User Value [BlockReady]

* Parameter	1	* Enforce Bounds	False
-------------	---	------------------	-------

#### User Value [ShellLength]

* Parameter	16 ft	* Enforce Bounds	False
-------------	-------	------------------	-------

\* User Specified Values

? Extrapolated or Approximate Values

ProMax 5.0.19050.0

Copyright © 2002-2019 BRE Group, Ltd.

Licensed to Esso Exploration, Inc.



## User Value Sets Report

Client Name:	DELAWARE DIVISION	Job:
Location:	Bulldog Compressor Station	

### User Value [ShellDiam]

* Parameter	15.5 ft	* Enforce Bounds	False
-------------	---------	------------------	-------

### User Value [BreatherVP]

* Parameter	0.03 psig	* Enforce Bounds	False
-------------	-----------	------------------	-------

### User Value [BreatherVacP]

* Parameter	-0.03 psig	* Enforce Bounds	False
-------------	------------	------------------	-------

### User Value [DomeRadius]

* Enforce Bounds	False		
------------------	-------	--	--

### User Value [OpPress]

* Parameter	0.25 psig	* Enforce Bounds	False
-------------	-----------	------------------	-------

### User Value [AvgPercentLiq]

* Parameter	50 %	* Enforce Bounds	False
-------------	------	------------------	-------

### User Value [MaxPercentLiq]

* Parameter	90 %	* Enforce Bounds	False
-------------	------	------------------	-------

### User Value [MinPercentLiq]

* Parameter	10 %	* Enforce Bounds	False
-------------	------	------------------	-------

### User Value [AnnNetTP]

* Parameter	341.738 bbl/day	* Enforce Bounds	False
-------------	-----------------	------------------	-------

### User Value [OREff]

* Parameter	0 %	* Enforce Bounds	False
-------------	-----	------------------	-------

### User Value [MaxAvgT]

* Parameter	75.8 °F	* Enforce Bounds	False
-------------	---------	------------------	-------

### User Value [MinAvgT]

* Parameter	47.6 °F	* Enforce Bounds	False
-------------	---------	------------------	-------

### User Value [BulkLiqT]

* Parameter	75.67 °F	* Enforce Bounds	False
-------------	----------	------------------	-------

### User Value [AvgP]

* Parameter	12.88 psia	* Enforce Bounds	False
-------------	------------	------------------	-------

### User Value [ThermI]

* Parameter	1722 Btu/ft <sup>2</sup> /day	* Enforce Bounds	False
-------------	-------------------------------	------------------	-------

### User Value [AvgWindSpeed]

* Parameter	8.7 mi/h	* Enforce Bounds	False
-------------	----------	------------------	-------

### User Value [MaxHourlyLoadingRate]

* Parameter	210 bbl/hr	* Enforce Bounds	False
-------------	------------	------------------	-------

## User Value Sets Report

Client Name:	DELAWARE DIVISION	Job:
Location:	Bulldog Compressor Station	

### User Value [SumLiqLevelInc]

* Enforce Bounds	False
------------------	-------

### User Value [FlashingT]

* Parameter	82.6855 °F	* Enforce Bounds	False
-------------	------------	------------------	-------

### User Value [EntrainedOilFrac]

* Parameter	1 %	* Enforce Bounds	False
-------------	-----	------------------	-------

### User Value [TurnoverRate]

* Parameter	144.966	* Enforce Bounds	False
-------------	---------	------------------	-------

### User Value [LLossSatFactor]

* Parameter	0.6	* Enforce Bounds	False
-------------	-----	------------------	-------

### User Value [AtmPressure]

* Parameter	12.88 psia	* Enforce Bounds	False
-------------	------------	------------------	-------

### User Value [TVP]

* Parameter	12.8672 psia	* Enforce Bounds	False
-------------	--------------	------------------	-------

### User Value [MaxVP]

* Parameter	14.4348 psia	* Enforce Bounds	False
-------------	--------------	------------------	-------

### User Value [MinVP]

* Parameter	11.3779 psia	* Enforce Bounds	False
-------------	--------------	------------------	-------

### User Value [AvgLiqSurfaceT]

* Parameter	73.5062 °F	* Enforce Bounds	False
-------------	------------	------------------	-------

### User Value [MaxLiqSurfaceT]

* Parameter	82.6855 °F	* Enforce Bounds	False
-------------	------------	------------------	-------

### User Value [TotalLosses]

* Parameter	0.941029 ton/yr	* Enforce Bounds	False
-------------	-----------------	------------------	-------

### User Value [WorkingLosses]

* Parameter	0.378072 ton/yr	* Enforce Bounds	False
-------------	-----------------	------------------	-------

### User Value [StandingLosses]

* Parameter	0.0924424 ton/yr	* Enforce Bounds	False
-------------	------------------	------------------	-------

### User Value [RimSealLosses]

* Parameter	0 ton/yr	* Enforce Bounds	False
-------------	----------	------------------	-------

### User Value [WithdrawalLoss]

* Parameter	0 ton/yr	* Enforce Bounds	False
-------------	----------	------------------	-------

### User Value [LoadingLosses]

* Parameter	0.450142 ton/yr	* Enforce Bounds	False
-------------	-----------------	------------------	-------

### User Value [MaxHourlyLoadingLoss]

* Parameter	1.5157 lb/hr	* Enforce Bounds	False
-------------	--------------	------------------	-------

\* User Specified Values  
? Extrapolated or Approximate Values

ProMax 5.0.19050.0  
Copyright © 2002-2019 BRE Group, Ltd.

Licensed to Esso Exploration, Inc.

## User Value Sets Report

Client Name:	DELAWARE DIVISION	Job:
Location:	Bulldog Compressor Station	

### User Value [PStar]

* Enforce Bounds	False
------------------	-------

### User Value [AllCTotalLosses]

* Parameter	1.67313 ton/yr	* Enforce Bounds	False
-------------	----------------	------------------	-------

### User Value [AllCLoadingLosses]

* Parameter	0.800346 ton/yr	* Enforce Bounds	False
-------------	-----------------	------------------	-------

### User Value [AllCMaxHLoadingLoss]

* Parameter	2.69489 lb/hr	* Enforce Bounds	False
-------------	---------------	------------------	-------

### User Value [AllCFlashingLosses]

* Parameter	0 ton/yr	* Enforce Bounds	False
-------------	----------	------------------	-------

### User Value [DeckFittingLosses]

* Parameter	0 ton/yr	* Enforce Bounds	False
-------------	----------	------------------	-------

### User Value [DeckSeamLosses]

* Parameter	0 ton/yr	* Enforce Bounds	False
-------------	----------	------------------	-------

### User Value [FlashingLosses]

* Parameter	0 ton/yr	* Enforce Bounds	False
-------------	----------	------------------	-------

### User Value [TotalResidual]

* Parameter	21795.8 ton/yr	* Enforce Bounds	False
-------------	----------------	------------------	-------

### User Value [GasMoleWeight]

* Parameter	0.0497059 kg/mol	* Enforce Bounds	False
-------------	------------------	------------------	-------

### User Value [VapReportableFrac]

* Parameter	56.2435 %	* Enforce Bounds	False
-------------	-----------	------------------	-------

### User Value [LiqReportableFrac]

* Parameter	0.0310499 %	* Enforce Bounds	False
-------------	-------------	------------------	-------

### User Value [FlashReportableFrac]

* Parameter	0 %	* Enforce Bounds	False
-------------	-----	------------------	-------

#### Remarks

This User Value Set was programmatically generated. GUID={A8E03E5F-3B81-409B-BA33-BC864AC8215C}

01/03/2020

**FESCO, Ltd.**  
**1100 Fesco Ave. - Alice, Texas 78332**

**For:** XTO Energy, Inc.  
22777 Springswoods Village Pkwy., W4.6B.345  
Spring, Texas 77389

**Sample:** Muy Wano 18 Tank Battery  
Inlet Separator  
Spot Gas Sample @ 124 psig & 110 °F

Date Sampled: 12/17/2019

Job Number: 193997.011

**CHROMATOGRAPH EXTENDED ANALYSIS - GPA 2286**

<b>COMPONENT</b>	<b>MOL%</b>	<b>GPM</b>
Hydrogen Sulfide*	< 0.001	
Nitrogen	0.864	
Carbon Dioxide	0.121	
Methane	73.632	
Ethane	12.988	3.558
Propane	6.704	1.892
Isobutane	0.949	0.318
n-Butane	2.303	0.744
2-2 Dimethylpropane	0.010	0.004
Isopentane	0.551	0.206
n-Pentane	0.654	0.243
Hexanes	0.513	0.216
Heptanes Plus	<u>0.711</u>	<u>0.302</u>
Totals	100.000	7.484

**Computed Real Characteristics Of Heptanes Plus:**

Specific Gravity ----- 3.402 (Air=1)  
Molecular Weight ----- 98.09  
Gross Heating Value ----- 5217 BTU/CF

**Computed Real Characteristics Of Total Sample:**

Specific Gravity ----- 0.793 (Air=1)  
Compressibility (Z) ----- 0.9955  
Molecular Weight ----- 22.88  
Gross Heating Value  
Dry Basis ----- 1394 BTU/CF  
Saturated Basis ----- 1371 BTU/CF

\*Hydrogen Sulfide tested on location by: Stain Tube Method (GPA 2377)  
Results: 0.038 Gr/100 CF, 0.6 PPMV or <0.0001 Mol%

Base Conditions: 15.025 PSI & 60 Deg F

Sampled By: (24) DF  
Analyst: LPJ  
Processor: RG  
Cylinder ID: T-5881

Certified: FESCO, Ltd. - Alice, Texas

David Dannhaus 361-661-7015

**CHROMATOGRAPH EXTENDED ANALYSIS - GPA 2286  
TOTAL REPORT**

COMPONENT	MOL %	GPM	WT %
Hydrogen Sulfide*	< 0.001		< 0.001
Nitrogen	0.864		1.058
Carbon Dioxide	0.121		0.233
Methane	73.632		51.636
Ethane	12.988	3.558	17.072
Propane	6.704	1.892	12.923
Isobutane	0.949	0.318	2.411
n-Butane	2.303	0.744	5.851
2,2 Dimethylpropane	0.010	0.004	0.032
Isopentane	0.551	0.206	1.738
n-Pentane	0.654	0.243	2.063
2,2 Dimethylbutane	0.008	0.003	0.030
Cyclopentane	0.000	0.000	0.000
2,3 Dimethylbutane	0.045	0.019	0.170
2 Methylpentane	0.156	0.066	0.588
3 Methylpentane	0.083	0.035	0.313
n-Hexane	0.221	0.093	0.833
Methylcyclopentane	0.088	0.031	0.324
Benzene	0.015	0.004	0.051
Cyclohexane	0.102	0.036	0.375
2-Methylhexane	0.032	0.015	0.140
3-Methylhexane	0.034	0.016	0.149
2,2,4 Trimethylpentane	0.000	0.000	0.000
Other C7's	0.088	0.039	0.382
n-Heptane	0.076	0.036	0.333
Methylcyclohexane	0.097	0.040	0.416
Toluene	0.020	0.007	0.081
Other C8's	0.087	0.041	0.419
n-Octane	0.024	0.013	0.120
Ethylbenzene	0.001	0.000	0.005
M & P Xylenes	0.008	0.003	0.037
O-Xylene	0.002	0.001	0.009
Other C9's	0.027	0.014	0.149
n-Nonane	0.005	0.003	0.028
Other C10's	0.004	0.002	0.025
n-Decane	0.001	0.001	0.006
Undecanes (11)	<u>0.000</u>	<u>0.000</u>	<u>0.000</u>
Totals	100.000	7.484	100.000

Computed Real Characteristics of Total Sample

Specific Gravity -----	0.793	(Air=1)
Compressibility (Z) -----	0.9955	
Molecular Weight -----	22.88	
Gross Heating Value		
Dry Basis -----	1394	BTU/CF
Saturated Basis -----	1371	BTU/CF

**FESCO, Ltd.**  
**1100 Fesco Ave. - Alice, Texas 78332**

**Sample:** Muy Wano 18 Tank Battery  
 Inlet Separator  
 Spot Gas Sample @ 124 psig & 110 °F

Date Sampled: 12/17/2019

Job Number: 193997.011

**GLYCALC FORMAT**

<b>COMPONENT</b>	<b>MOL%</b>	<b>GPM</b>	<b>Wt %</b>
Carbon Dioxide	0.121		0.233
Hydrogen Sulfide	< 0.001		< 0.001
Nitrogen	0.864		1.058
Methane	73.632		51.636
Ethane	12.988	3.558	17.072
Propane	6.704	1.892	12.923
Isobutane	0.949	0.318	2.411
n-Butane	2.313	0.748	5.883
Isopentane	0.551	0.206	1.738
n-Pentane	0.654	0.243	2.063
Cyclopentane	0.000	0.000	0.000
n-Hexane	0.221	0.093	0.833
Cyclohexane	0.102	0.036	0.375
Other C6's	0.292	0.123	1.101
Heptanes	0.318	0.137	1.328
Methylcyclohexane	0.097	0.040	0.416
2,2,4 Trimethylpentane	0.000	0.000	0.000
Benzene	0.015	0.004	0.051
Toluene	0.020	0.007	0.081
Ethylbenzene	0.001	0.000	0.005
Xylenes	0.010	0.004	0.046
Octanes Plus	<u>0.148</u>	<u>0.074</u>	<u>0.747</u>
Totals	100.000	7.484	100.000

**Real Characteristics Of Octanes Plus:**

Specific Gravity ----- 4.004 (Air=1)  
 Molecular Weight ----- 115.46  
 Gross Heating Value ----- 6049 BTU/CF

**Real Characteristics Of Total Sample:**

Specific Gravity ----- 0.793 (Air=1)  
 Compressibility (Z) ----- 0.9955  
 Molecular Weight ----- 22.88  
 Gross Heating Value  
 Dry Basis ----- 1394 BTU/CF  
 Saturated Basis ----- 1371 BTU/CF

January 16, 2020

FESCO, Ltd.  
1100 FESCO Avenue - Alice, Texas 78332

For: XTO Energy, Inc.  
22777 Springswoods Village Pkwy., W4.6B.345  
Spring, Texas 77389

Sample: Wolverine Compressor Station  
Inlet Separator Hydrocarbon Liquid  
Sampled @ 100 psig & 61 °F

Date Sampled: 12/17/19

Job Number: 193998.012

CHROMATOGRAPH EXTENDED ANALYSIS - GPA 2186-M

COMPONENT	MOL %	LIQ VOL %	WT %
Nitrogen	0.017	0.005	0.006
Carbon Dioxide	0.013	0.006	0.008
Methane	2.847	1.310	0.603
Ethane	3.958	2.874	1.570
Propane	8.477	6.341	4.931
Isobutane	3.267	2.903	2.505
n-Butane	12.011	10.281	9.210
2,2 Dimethylpropane	0.114	0.119	0.109
Isopentane	8.130	8.073	7.739
n-Pentane	12.667	12.467	12.057
2,2 Dimethylbutane	0.157	0.178	0.179
Cyclopentane	0.000	0.000	0.000
2,3 Dimethylbutane	0.947	1.054	1.077
2 Methylpentane	4.348	4.900	4.943
3 Methylpentane	2.482	2.751	2.821
n-Hexane	7.509	8.384	8.537
Heptanes Plus	<u>33.056</u>	<u>38.355</u>	<u>43.705</u>
Totals:	100.000	100.000	100.000

Characteristics of Heptanes Plus:

Specific Gravity -----	0.7431	(Water=1)
°API Gravity -----	58.92	@ 60°F
Molecular Weight -----	100.2	
Vapor Volume -----	22.95	CF/Gal
Weight -----	6.19	Lbs/Gal

Characteristics of Total Sample:

Specific Gravity -----	0.6521	(Water=1)
°API Gravity -----	85.48	@ 60°F
Molecular Weight -----	75.8	
Vapor Volume -----	26.62	CF/Gal
Weight -----	5.43	Lbs/Gal

Base Conditions: 15.025 PSI & 60 °F

Certified: FESCO, Ltd. - Alice, Texas

Sampled By: (24) DF  
Analyst: RR  
Processor: RLdjv  
Cylinder ID: W-1544

David Dannhaus 361-661-7015

**TANKS DATA INPUT REPORT - GPA 2186-M**

COMPONENT	Mol %	LiqVol %	Wt %
Carbon Dioxide	0.013	0.006	0.008
Nitrogen	0.017	0.005	0.006
Methane	2.847	1.310	0.603
Ethane	3.958	2.874	1.570
Propane	8.477	6.341	4.931
Isobutane	3.267	2.903	2.505
n-Butane	12.125	10.400	9.319
Isopentane	8.130	8.073	7.739
n-Pentane	12.667	12.467	12.057
Other C-6's	7.934	8.883	9.020
Heptanes	17.188	18.903	20.999
Octanes	10.539	12.691	14.604
Nonanes	1.643	2.375	2.743
Decanes Plus	0.746	1.256	1.510
Benzene	0.483	0.367	0.498
Toluene	0.991	0.901	1.204
E-Benzene	0.091	0.096	0.128
Xylenes	0.481	0.505	0.674
n-Hexane	7.509	8.384	8.537
2,2,4 Trimethylpentane	<u>0.893</u>	<u>1.260</u>	<u>1.346</u>
Totals:	100.000	100.000	100.000

**Characteristics of Total Sample:**

Specific Gravity -----	0.6521 (Water=1)
°API Gravity -----	85.48 @ 60°F
Molecular Weight-----	75.8
Vapor Volume -----	26.62 CF/Gal
Weight -----	5.43 Lbs/Gal

**Characteristics of Decanes (C10) Plus:**

Specific Gravity -----	0.7837 (Water=1)
Molecular Weight-----	153.4

**Characteristics of Atmospheric Sample:**

°API Gravity -----	73.81 @ 60°F
Reid Vapor Pressure Equivalent (D-6377)-----	15.83 psi

QUALITY CONTROL CHECK			
	Sampling Conditions	Test Samples	
Cylinder Number	-----	W-1544*	-----
Pressure, PSIG	100	110	-----
Temperature, °F	61	61	-----

\* Sample used for analysis



COMPONENT	Mol %	LiqVol %	Wt %
Nitrogen	0.017	0.005	0.006
Carbon Dioxide	0.013	0.006	0.008
Methane	2.847	1.310	0.603
Ethane	3.958	2.874	1.570
Propane	8.477	6.341	4.931
Isobutane	3.267	2.903	2.505
n-Butane	12.011	10.281	9.210
2,2 Dimethylpropane	0.114	0.119	0.109
Isopentane	8.130	8.073	7.739
n-Pentane	12.667	12.467	12.057
2,2 Dimethylbutane	0.157	0.178	0.179
Cyclopentane	0.000	0.000	0.000
2,3 Dimethylbutane	0.947	1.054	1.077
2 Methylpentane	4.348	4.900	4.943
3 Methylpentane	2.482	2.751	2.821
n-Hexane	7.509	8.384	8.537
Methylcyclopentane	3.546	3.407	3.937
Benzene	0.483	0.367	0.498
Cyclohexane	4.466	4.128	4.958
2-Methylhexane	1.797	2.268	2.375
3-Methylhexane	1.575	1.964	2.083
2,2,4 Trimethylpentane	0.893	1.260	1.346
Other C-7's	2.140	2.545	2.800
n-Heptane	3.665	4.591	4.845
Methylcyclohexane	4.915	5.364	6.366
Toluene	0.991	0.901	1.204
Other C-8's	4.505	5.771	6.551
n-Octane	1.119	1.556	1.686
E-Benzene	0.091	0.096	0.128
M & P Xylenes	0.393	0.413	0.550
O-Xylene	0.089	0.092	0.125
Other C-9's	1.383	1.979	2.304
n-Nonane	0.259	0.396	0.438
Other C-10's	0.442	0.696	0.825
n-decane	0.058	0.096	0.108
Undecanes(11)	0.142	0.229	0.275
Dodecanes(12)	0.044	0.077	0.094
Tridecanes(13)	0.020	0.037	0.045
Tetradecanes(14)	0.006	0.013	0.016
Pentadecanes(15)	0.004	0.008	0.010
Hexadecanes(16)	0.002	0.005	0.006
Heptadecanes(17)	0.002	0.005	0.006
Octadecanes(18)	0.000	0.000	0.000
Nonadecanes(19)	0.000	0.001	0.002
Eicosanes(20)	0.001	0.004	0.005
Heneicosanes(21)	0.001	0.002	0.002
Docosanes(22)	0.002	0.007	0.009
Tricosanes(23)	0.001	0.003	0.004
Tetracosanes(24)	0.003	0.009	0.013
Pentacosanes(25)	0.001	0.004	0.006
Hexacosanes(26)	0.004	0.015	0.020
Heptacosanes(27)	0.003	0.012	0.016
Octacosanes(28)	0.007	0.025	0.034
Nonacosanes(29)	0.003	0.011	0.015
Triacontanes(30)	0.000	0.000	0.000
Hentriacontanes Plus(31+)	<u>0.000</u>	<u>0.000</u>	<u>0.000</u>
Total	100.000	100.000	100.000

**Tab 8**  
**Section 8 - Map(s)**

**ITEM 2 - ECD - 60" Combustor 57.6 MCF/D Max - skid package with blowcase**

**Combustor details**

- Combustor:
  - Dimensions 60"D x 13'
  - p/n ECD60STD
    - Atmospheric MAWP
    - 6.1 MMBTU/HR
- Plumbing:
  - Stainless Steel Jets
  - per ARC config
    - Flamecell
    - 34"L x 41"W Burner
- Concrete pad:
  - p/n n/a
    - 3" Wenco Flame Arrestor
    - 3" NPT Inlet Connection
    - 1/4" Fisher 67CR-206 Pilot Regulator
- BMS p/n:
  - p/n 148392
    - Installed on a 6' x 10' skid, with (1) 24"x48" knockout drum, (1) 10.75"x36" blowcase, (1) 1" Kimray Direct acting, (1) 1" Kimray Reverse acting, (1) Kimray CUA Level Control, fully assembled and plumbed
    - Paint color: Black
    - ARC™ PREMIER BMS Package includes: smart auto-ignition, CLS I, DIV II (pending), Modbus RTU over RS-485, Advanced Datalogging, Premier combustion Kit: Includes (2) 1/4" 0.55W ASCO Solenoid Valves, 1/4" 0-5 PSI Transducer, (1) Dual Process Type K Thermocouple w/ Thermowell, no solar package, shipped loose

Item 2 Description	Quantity	Price Each
ECD - 60" Combustor 57.6 MCF/D Max w/ skid package with blowcase	1 to 4	\$27,760
	5+	\$25,817
ARC™ PREMIER BMS Package	1+	\$4,112

**Terms/Delivery**

Subject to Prior Sale / 7-8 weeks ARO, Ex Works Mfg Facility: Evans, CO, based on availability at time of quote.  
 Availability will be confirmed after receipt of Purchase Order.  
 Expediting 1-3 business days - 15% upcharge; 4-10 business days - 5% upcharge  
 Drawing is for information only. Unit specific drawing available upon request.

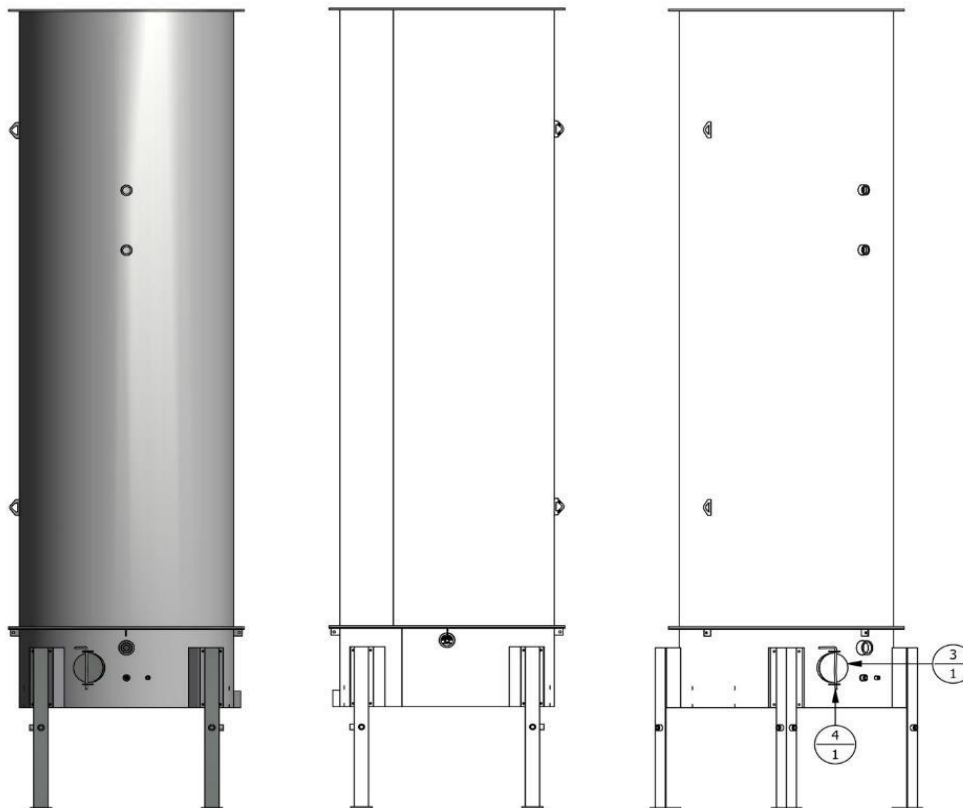

**EPA CERTIFIED**

## ENCLOSED COMBUSTORS



Cimarron's enclosed combustion units provide a clean, safe, and efficient solution for eliminating tank vapors and ensuring regulatory compliance. Their performance has been proven to exceed the US EPA's strict requirements with a greater than 99% destruction rate. Designed for both low and high volume applications, the enclosed flares are easy to install and require little ongoing maintenance. Ignition systems include automation capability and data logging features. Standard models have flame cells ranging from 24" to 60", with capacity of 2,000 to 75,000 SCFD. The larger high volume units contain four 24" flame cells and can accommodate up to 200,000 SCFD. ECDs typically operate at pressures of 1 to 12 oz/in<sup>2</sup>.

### DESIGN FEATURES AND OPTIONS

- Five Models Manufacturer Performance Tested as per NSPS OOOO §60.5413(d)
- Demonstrated VOC Destruction Efficiency >99%
- Eliminates the requirement for in-field testing to demonstrate continuous compliance.
- Solar powered BMS and data logging functions
- Cimarron actuator package for low flow and flameout shutdown
- Drip tank for free liquid removal
- Blowcase skids and modular package options available
- User friendly and easy to install

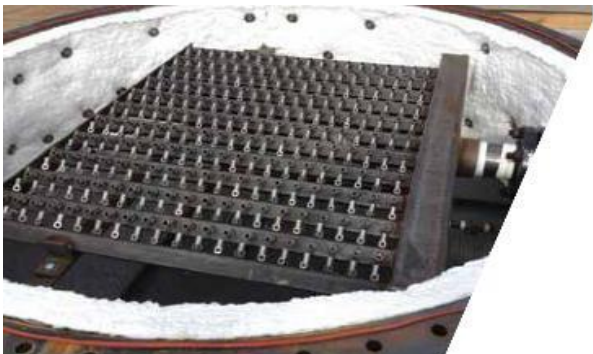

*All five models were approved by the EPA in December 2014 as "Manufacturer Tested" under Quad O guidelines.*





March 15, 2019

XTO Energy  
3104 E Greene St.  
Carlsbad, NM  
88220

Attention: To Whom It May Concern

Subject: Compliance with 40 CFR 60.18 Flare Requirements and Destruction Removal Efficiency Confirmation

The Tornado Combustion Technologies Inc. (TCTI) designed two (2) separate dual air assisted flare systems for XTO Energy Midstream Operations Compressor Facilities designed with a maximum buildout design flowrate of 100 to 180 MMSCFD, as per XTO Energy/Select Engineering Flare Specification 1332-SP-P-013 (XTO Energy/Select Engineering Project No.: 1332) on February 20, 2018 (TCTI Design Reference No.: TOR0218 Rev. 0).

The first flare has a 30-inch outer diameter air tip, 22-inch outer diameter annular low pressure air assisted waste gas tip for continuous flaring operations, and 20-inch outer diameter high pressure waste gas tip for facility emergency relieving cases. The tip as previously described is mounted on a riser and guy wire supporting structure so that the overall flare height is 140-feet tall. To date TCTI has provided One (1) flare of this design to XTO Energy Midstream Operations Compressor Facilities, under the following job number:

- 14170 (16495).

This flare design is intended to operate such that:

- i) The maximum high pressure emergency flow rate does not exceed a maximum flow rate of 59,767,069 SCFD, and a maximum net heat release of 6,069,175,258.85 BTU/h; and,
- ii) The maximum low pressure intermittent flow rate does not exceed a maximum flow rate of 952,833 SCFD, a maximum continuous flowrate of 124,363 SCFD which will operate without visible emissions (i.e. excessive soot formation) and a maximum net heat release of 104,435,128.72 BTU/h. For more detailed information please refer to the enclosed design datasheets.

To meet the requirements of 40 CFR 60.18 and industry best practices Tornado has designed the flare to operate as follows:

- TCTI has been designed the flare so each riser of the dual flare system will operate independently. Thus the calculated 40 CFR 60.18 maximum exit velocity for the high pressure non-assisted flare is 391.39 ft/s, 377.63 ft/s and 400 ft/s, for the winter and summer heavy, and winter and summer rich and lean cases respectfully, and low pressure air assisted flare is 170.85 ft/s, 258.33 ft/s, 220.10 ft/s, 146.38 ft/s, 248.24 ft/s and 219.78 ft/s, for the winter and summer heavy, rich and lean cases respectfully, as per paragraphs (c)(3)(ii), (c)(4)(iii), (c)(5), and (f)(6). The actual exit velocities of the flare as determined by paragraph (f)(4) in 40 CFR 60.18, are 364.15 ft/s, 348.57 ft/s, 356.60 ft/s, 367.91 ft/s, 366.37 ft/s, and 372.10 ft/s, for the winter and summer heavy, rich and lean cases respectfully, and low pressure air assisted flare is 11.05 ft/s, 41.31 ft/s, 7.79 ft/s, 18.71 ft/s, 27.39 ft/s and 17.56 ft/s, for the winter and summer heavy, rich and lean cases respectfully. As can be seen the actual exit velocity of each low pressure air assisted flare is within the requirements of 40 CFR 60.18. The high pressure air assisted flare's exit velocity although greater than the requirements of 40 CFR

60.18, is exempt from compliance with the standard as per Section 40 CFR 60.11 paragraph (a), and 40 CFR 60.8 paragraph (c), as all cases presented to TCTI for the high pressure air assisted flare have been presented as emergency cases, that are not representative of the flare's performance;

- The calculated lower heating value of the waste gas for the high pressure non-assisted flare are 992.73 BTU/SCF, 1,233.19 BTU/SCF, 1,262.23 BTU/SCF, 979.52 BTU/SCF, 1,222.20 BTU/SCF, and 1,287.62 BTU/SCF, for the winter and summer heavy, rich and lean cases respectfully, and low pressure air assisted flare are 1,641.36 BTU/SCF, 2,650.44 BTU/SCF, 742.52 BTU/SCF, 1,926.09 BTU/SCF, 2,965.73 BTU/SCF, and 1,658.18 BTU/SCF, for the winter and summer heavy, rich and lean cases respectfully. The lower heating value of the provided waste gas composition was calculated as per paragraph (f)(3) of 40 CFR 60.18. This complies with paragraphs (c)(3)(ii) of 40 CFR 60.18 for both a non-assisted and an air assisted flare, as the heating value of the waste gas is greater than 200 BTU/SCF and 300 BTU/SCF, respectfully;
- Tornado has designed this flare to operate with a TSI #6 pilot and TPMR automatic relight and pilot monitoring system. If the flame failure contact is monitored by the client to the satisfaction of the local environmental authority having jurisdiction, then this complies with paragraph (f)(2) of 40 CFR 60.18;
- Tornado has designed the flare to modulate the air flow based upon the waste gas flow rate to the flare for the cases presented which are not considered startup, shutdown, or malfunction as per 40 CFR 60.8(c). By doing this in conjunction with proper flare tuning, the flare's air blower cannot introduce too much air into the jet exit stream thus lowering the destruction efficiency of the flare by quenching mechanisms.

The second flare has a 30-inch outer diameter air tip, 22.5-inch outer diameter annular low pressure air assisted waste gas tip for continuous flaring operations, and 21-inch outer diameter high pressure waste gas tip for facility emergency relieving cases. The tip as previously described is mounted on a riser and guy wire supporting structure so that the overall flare height is 145-feet tall. To date TCTI has provided eleven (11) flares of this design to XTO Energy Midstream Operations Compressor Facilities, under the following job numbers:

- 14274;
- 14275;
- 14276;
- 14277A;
- 14277B;
- 14278A;
- 14278B;
- 14287;
- 14318;
- 14319A;
- 14319B.

This flare design is intended to operate such that:

- i) The maximum high pressure emergency flow rate does not exceed a maximum flow rate of 70,000,000 SCFD, and a maximum net heat release of 7,108,300,193 BTU/h; and,
- ii) The maximum low pressure intermittent flow rate does not exceed a maximum flow rate of 952,833 SCFD, a maximum continuous flowrate of 124,363 SCFD which will operate without visible emissions (i.e. excessive soot formation) and a maximum net heat release of 104,435,128.72 BTU/h. For more detailed information please refer to the enclosed design datasheets.

Due to the volume of sales of this flare design to XTO Energy specifically TCTI has provided this flare with the following model designation moving forward:

- XTO0218R0-145FT.

Thus either the above provided TCTI job numbers or above model number can be used to relate back to this design and the intended operating parameters of the flare system design.

To meet the requirements of 40 CFR 60.18 and industry best practices Tornado has designed the flare to operate as follows:

- TCTI has been designed the flare so each riser of the dual flare system will operate independently. Thus the calculated 40 CFR 60.18 maximum exit velocity for the high pressure non-assisted flare is 391.39 ft/s, 377.63 ft/s and 400 ft/s, for the winter and summer heavy, and winter and summer rich and lean cases respectfully, and low pressure air assisted flare is 170.85 ft/s, 258.33 ft/s, 220.10 ft/s, 146.38 ft/s, 248.24 ft/s and 219.78 ft/s, for the winter and summer heavy, rich and lean cases respectfully, as per paragraphs (c)(3)(ii), (c)(4)(iii), (c)(5), and (f)(6). The actual exit velocities of the flare as determined by paragraph (f)(4) in 40 CFR 60.18, are 415.42 ft/s, 400.47 ft/s, 409.91 ft/s, 420.94 ft/s, 420.19 ft/s, and 426.12 ft/s, for the winter and summer heavy, rich and lean cases respectfully, and low pressure air assisted flare is 11.05 ft/s, 41.31 ft/s, 7.79 ft/s, 18.71 ft/s, 27.39 ft/s and 17.56 ft/s, for the winter and summer heavy, rich and lean cases respectfully. As can be seen the actual exit velocity of each low pressure air assisted flare is within the requirements of 40 CFR 60.18. The high pressure air assisted flare's exit velocity although greater than the requirements of 40 CFR 60.18, is exempt from compliance with the standard as per Section 40 CFR 60.11 paragraph (a), and 40 CFR 60.8 paragraph (c), as all cases presented to TCTI for the high pressure air assisted flare have been presented as emergency cases, that are not representative of the flare's performance;
- The calculated lower heating value of the waste gas for the high pressure non-assisted flare are 992.73 BTU/SCF, 1,233.19 BTU/SCF, 1,262.23 BTU/SCF, 979.52 BTU/SCF, 1,222.20 BTU/SCF, and 1,287.62 BTU/SCF, for the winter and summer heavy, rich and lean cases respectfully, and low pressure air assisted flare are 1,641.36 BTU/SCF, 2,650.44 BTU/SCF, 742.52 BTU/SCF, 1,926.09 BTU/SCF, 2,965.73 BTU/SCF, and 1,658.18 BTU/SCF, for the winter and summer heavy, rich and lean cases respectfully. The lower heating value of the provided waste gas composition was calculated as per paragraph (f)(3) of 40 CFR 60.18. This complies with paragraphs (c)(3)(ii) of 40 CFR 60.18 for both a non-assisted and an air assisted flare, as the heating value of the waste gas is greater than 200 BTU/SCF and 300 BTU/SCF, respectfully;
- Tornado has designed this flare to operate with a TSI #6 pilot and TPMR automatic relight and pilot monitoring system. If the flame failure contact is monitored by the client to the satisfaction of the local environmental authority having jurisdiction, then this complies with paragraph (f)(2) of 40 CFR 60.18;
- Tornado has designed the flare to modulate the air flow based upon the waste gas flow rate to the flare for the cases presented which are not considered startup, shutdown, or malfunction as per 40 CFR 60.8(c). By doing this in conjunction with proper flare tuning, the flare's air blower cannot introduce too much air into the jet exit stream thus lowering the destruction efficiency of the flare by quenching mechanisms.

With both flares being designed to operate as described above the Tornado Combustion Technologies Inc. flare system has been designed to operate in compliance with 40 CFR 60.18. As per EPA studies EPA-600/2-83-052, EPA-600/2-86-080, and EPA-600/2-85-106 meeting the criteria of 40 CFR 60.18 will attain a minimum Destruction Removal Efficiency (DRE) of 98% for hydrocarbon compounds.

XTO Energy has advised that the site under consideration does not need to meet the requirements of 40 CFR 60 Subpart OOOO and only the general requirements must be adhered.

Regards,

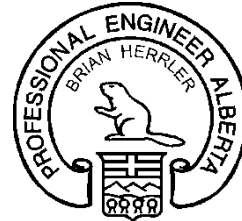
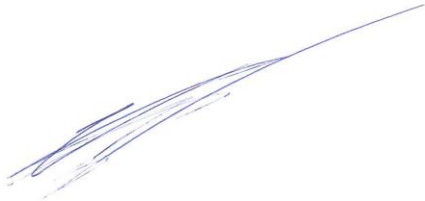

Permit Number: P10806  
Date: 2019-03-15

Brian Herrler, P.Eng  
Combustion Engineering  
**Tornado Combustion Technologies Inc.**  
200 – 261200 Wagon Wheel Way  
Municipal District of Rocky View, Alberta  
T4A 0E3  
Phone: (403) 244-3333  
Direct: (403) 567-2223  
Mobile: (403) 669-3400  
Email: bherrler@tornadotech.com

Cc:(4) Gene Kazmir, General Manager USA, Tornado Combustion Technologies Inc;  
Cliff Kazmir, General Manager USA, Tornado Combustion Technologies Inc;  
Bryce Thomas, Flare Manager, Tornado Combustion Technologies Inc;  
Ian Burge, Combustion Engineering, Tornado Combustion Technologies Inc.



GAS COMPRESSION APPLICATION

ENGINE SPEED (rpm):	1400	RATING STRATEGY:	STANDARD
COMPRESSION RATIO:	8	FUEL SYSTEM:	CAT WIDE RANGE
AFTERCOOLER TYPE:	SCAC	<b>SITE CONDITIONS:</b>	WITH AIR FUEL RATIO CONTROL
AFTERCOOLER - STAGE 2 INLET (°F):	130	FUEL:	7.0-40.0
AFTERCOOLER - STAGE 1 INLET (°F):	201	FUEL PRESSURE RANGE (psig): (See note 1)	48.1
JACKET WATER OUTLET (°F):	210	FUEL METHANE NUMBER:	1126
ASPIRATION:	TA	FUEL LHV (Btu/scf):	1067
COOLING SYSTEM:	JW+OC+1AC, 2AC	ALTITUDE(ft):	77
CONTROL SYSTEM:	ADEM3	INLET AIR TEMPERATURE(°F):	1380 bhp@1400rpm
EXHAUST MANIFOLD:	ASWC	STANDARD RATED POWER:	
COMBUSTION:	LOW EMISSION		
NOx EMISSION LEVEL (g/bhp-hr NOx):	0.5		
SET POINT TIMING:	28		

RATING	NOTES	LOAD	SITE RATING AT MAXIMUM INLET AIR TEMPERATURE			
			100%	100%	75%	50%
ENGINE POWER (WITHOUT FAN)	(2)	bhp	1380	1380	1035	690
INLET AIR TEMPERATURE		°F	77	77	77	77

ENGINE DATA							
FUEL CONSUMPTION (LHV)		(3)	Btu/bhp-hr	7344	7344	7709	8286
FUEL CONSUMPTION (HHV)		(3)	Btu/bhp-hr	8095	8095	8497	9133
AIR FLOW (@inlet air temp, 14.7 psia)	(WET)	(4)(5)	ft3/min	3130	3130	2392	1642
AIR FLOW	(WET)	(4)(5)	lb/hr	13879	13879	10606	7283
FUEL FLOW (60°F, 14.7 psia)			scfm	150	150	118	85
INLET MANIFOLD PRESSURE		(6)	in Hg(abs)	87.9	87.9	69.9	48.1
EXHAUST TEMPERATURE - ENGINE OUTLET		(7)	°F	837	837	835	892
EXHAUST GAS FLOW (@engine outlet temp, 14.5 psia)	(WET)	(8)(5)	ft3/min	8108	8108	6197	4453
EXHAUST GAS MASS FLOW	(WET)	(8)(5)	lb/hr	14383	14383	11002	7567

EMISSIONS DATA - ENGINE OUT							
NOx (as NO2)		(9)(10)	g/bhp-hr	0.50	0.50	0.50	0.50
CO		(9)(10)	g/bhp-hr	2.55	2.55	2.56	2.47
THC (mol. wt. of 15.84)		(9)(10)	g/bhp-hr	3.77	3.77	3.68	3.47
NMHC (mol. wt. of 15.84)		(9)(10)	g/bhp-hr	1.52	1.52	1.49	1.41
NMNEHC (VOCs) (mol. wt. of 15.84)		(9)(10)(11)	g/bhp-hr	0.91	0.91	0.89	0.84
HCHO (Formaldehyde)		(9)(10)	g/bhp-hr	0.36	0.36	0.34	0.33
CO2		(9)(10)	g/bhp-hr	502	502	525	568
EXHAUST OXYGEN		(9)(12)	% DRY	9.1	9.1	8.8	8.4

HEAT REJECTION							
HEAT REJ. TO JACKET WATER (JW)		(13)	Btu/min	36153	36153	31130	25945
HEAT REJ. TO ATMOSPHERE		(13)	Btu/min	5313	5313	4428	3543
HEAT REJ. TO LUBE OIL (OC)		(13)	Btu/min	4370	4370	3763	3136
HEAT REJ. TO A/C - STAGE 1 (1AC)		(13)(14)	Btu/min	7839	7839	5810	1168
HEAT REJ. TO A/C - STAGE 2 (2AC)		(13)(14)	Btu/min	5064	5064	4393	2761

COOLING SYSTEM SIZING CRITERIA							
TOTAL JACKET WATER CIRCUIT (JW+OC+1AC)		(14)(15)	Btu/min	53243			
TOTAL AFTERCOOLER CIRCUIT (2AC)		(14)(15)	Btu/min	5317			

A cooling system safety factor of 0% has been added to the cooling system sizing criteria.

**CONDITIONS AND DEFINITIONS**  
 Engine rating obtained and presented in accordance with ISO 3046/1, adjusted for fuel, site altitude and site inlet air temperature. 100% rating at maximum inlet air temperature is the maximum engine capability for the specified fuel at site altitude and maximum site inlet air temperature. Maximum rating is the maximum capability at the specified aftercooler inlet temperature for the specified fuel at site altitude and reduced inlet air temperature. Lowest load point is the lowest continuous duty operating load allowed. No overload permitted at rating shown.

For notes information consult page three.

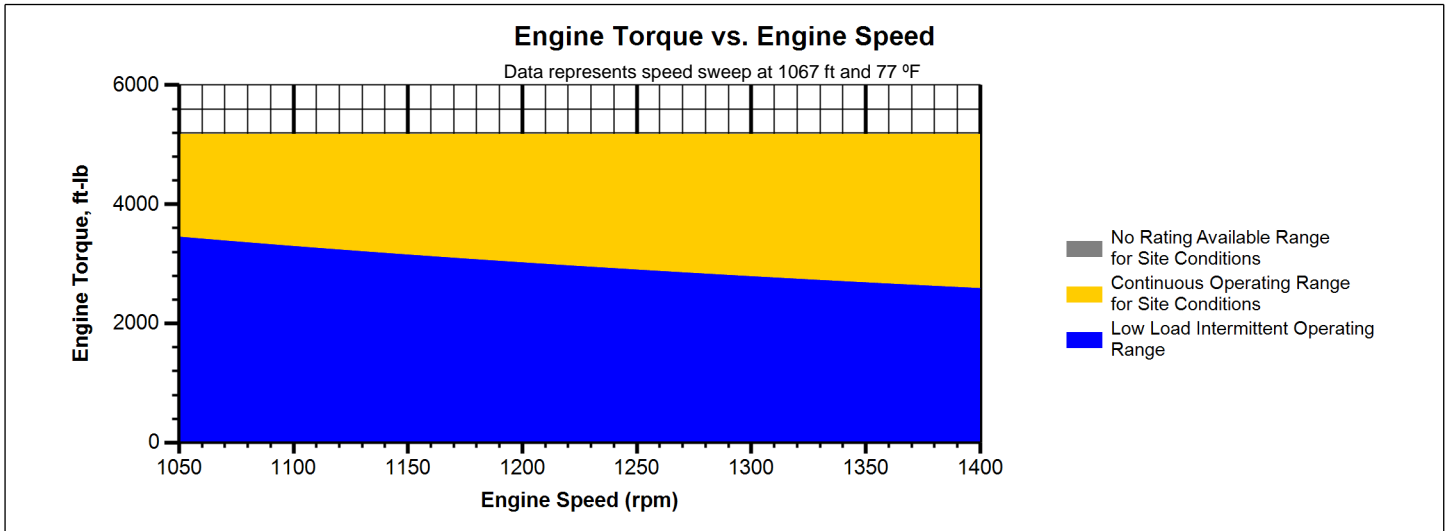
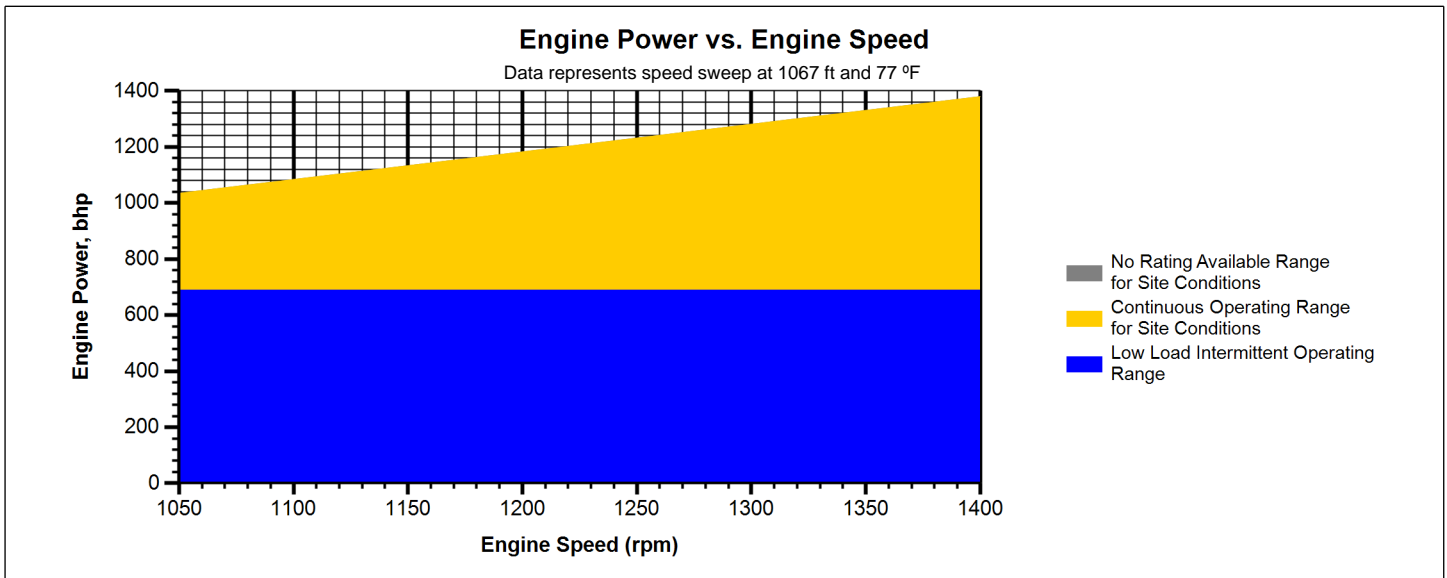
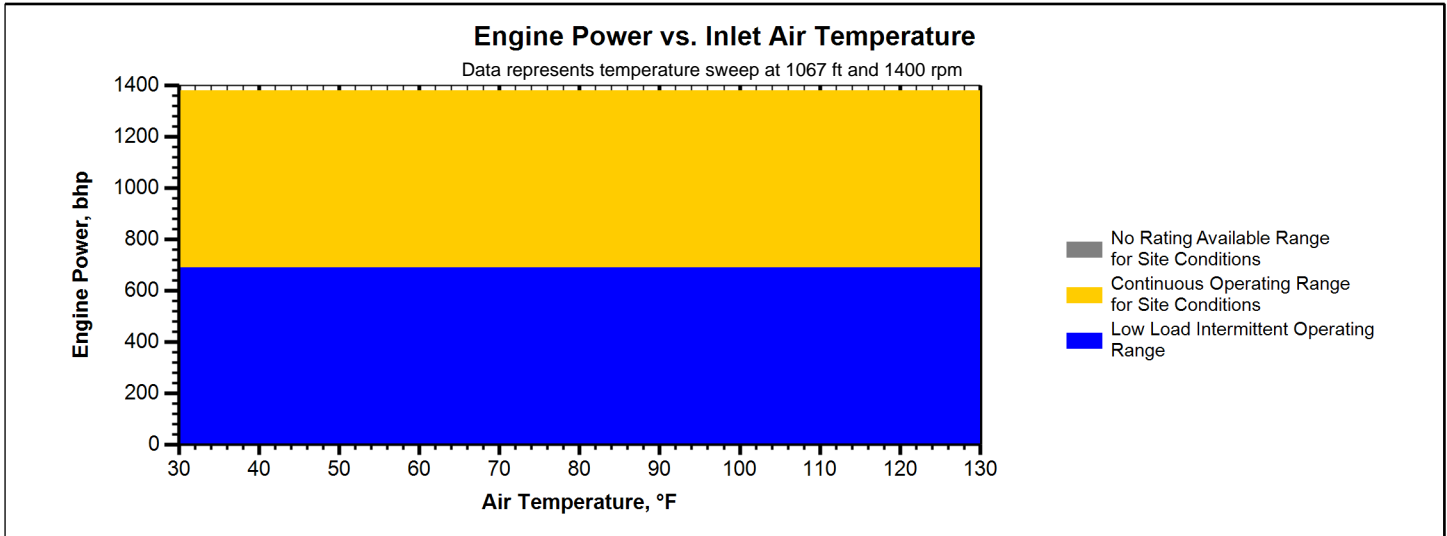

**Note:**

At site conditions of 1067 ft and 77°F inlet air temp., constant torque can be maintained down to 1050 rpm. The minimum speed for loading at these conditions is 1050 rpm.

**NOTES:**

1. Fuel pressure range specified is to the engine fuel pressure regulator. Additional fuel train components should be considered in pressure and flow calculations.
2. Engine rating is with two engine driven water pumps. Tolerance is  $\pm 3\%$  of full load.
3. Engine rating obtained and presented in accordance with ISO 3046/1, adjusted for fuel, site altitude and site ambient temperature.
4. Air flow value is on a 'wet' basis. Flow is a nominal value with a tolerance of  $\pm 5\%$ .
5. Inlet and Exhaust Restrictions must not exceed A&I limits based on full load flow rates from the standard technical data sheet.
6. Inlet manifold pressure is a nominal value with a tolerance of  $\pm 5\%$ .
7. Exhaust temperature is a nominal value with a tolerance of (+)63°F, (-)54°F.
8. Exhaust flow value is on a "wet" basis. Flow is a nominal value with a tolerance of  $\pm 6\%$ .
9. Emissions data is at engine exhaust flange prior to any after treatment.
10. Values listed are higher than nominal levels to allow for instrumentation, measurement, and engine-to-engine variations. They indicate the maximum values expected under steady state conditions. Fuel methane number cannot vary more than  $\pm 3$ . THC, NMHC, and NMNEHC do not include aldehydes. An oxidation catalyst may be required to meet Federal, State or local CO or HC requirements.
11. VOCs - Volatile organic compounds as defined in US EPA 40 CFR 60, subpart JJJJ
12. Exhaust Oxygen level is the result of adjusting the engine to operate at the specified NOx level. Tolerance is  $\pm 0.5$ .
13. Heat rejection values are nominal. Tolerances, based on treated water, are  $\pm 10\%$  for jacket water circuit,  $\pm 50\%$  for radiation,  $\pm 20\%$  for lube oil circuit, and  $\pm 5\%$  for aftercooler circuit.
14. Aftercooler heat rejection includes an aftercooler heat rejection factor for the site elevation and inlet air temperature specified. Aftercooler heat rejection values at part load are for reference only. Do not use part load data for heat exchanger sizing.
15. Cooling system sizing criteria are maximum circuit heat rejection for the site, with applied tolerances.

## GAS COMPRESSION APPLICATION

Constituent	Abbrev	Mole %	Norm
Water Vapor	H2O	0.0000	0.0000
Methane	CH4	78.0190	78.0190
Ethane	C2H6	10.6670	10.6670
Propane	C3H8	4.8170	4.8170
Isobutane	iso-C4H10	0.5560	0.5560
Norbutane	nor-C4H10	1.4030	1.4030
Isopentane	iso-C5H12	0.3190	0.3190
Noropentane	nor-C5H12	0.3610	0.3610
Hexane	C6H14	0.3720	0.3720
Heptane	C7H16	0.5440	0.5440
Nitrogen	N2	2.0010	2.0010
Carbon Dioxide	CO2	0.9410	0.9410
Hydrogen Sulfide	H2S	0.0000	0.0000
Carbon Monoxide	CO	0.0000	0.0000
Hydrogen	H2	0.0000	0.0000
Oxygen	O2	0.0000	0.0000
Helium	HE	0.0000	0.0000
Neopentane	neo-C5H12	0.0000	0.0000
Octane	C8H18	0.0000	0.0000
Nonane	C9H20	0.0000	0.0000
Ethylene	C2H4	0.0000	0.0000
Propylene	C3H6	0.0000	0.0000
TOTAL (Volume %)		100.0000	100.0000

Fuel Makeup:  
Unit of Measure:

English

**Calculated Fuel Properties**

Caterpillar Methane Number:	48.1
Lower Heating Value (Btu/scf):	1126
Higher Heating Value (Btu/scf):	1241
WOBBE Index (Btu/scf):	1313
THC: Free Inert Ratio:	32.99
Total % Inerts (% N2, CO2, He):	2.942%
RPC (%) (To 905 Btu/scf Fuel):	100%
Compressibility Factor:	0.996
Stoich A/F Ratio (Vol/Vol):	11.68
Stoich A/F Ratio (Mass/Mass):	15.87
Specific Gravity (Relative to Air):	0.736
Fuel Specific Heat Ratio (K):	1.285

**CONDITIONS AND DEFINITIONS**

Caterpillar Methane Number represents the knock resistance of a gaseous fuel. It should be used with the Caterpillar Fuel Usage Guide for the engine and rating to determine the rating for the fuel specified. A Fuel Usage Guide for each rating is included on page 2 of its standard technical data sheet.

RPC always applies to naturally aspirated (NA) engines, and turbocharged (TA or LE) engines only when they are derated for altitude and ambient site conditions.

Project specific technical data sheets generated by the Caterpillar Gas Engine Rating Pro program take the Caterpillar Methane Number and RPC into account when generating a site rating.

Fuel properties for Btu/scf calculations are at 60F and 14.696 psia.

Caterpillar shall have no liability in law or equity, for damages, consequently or otherwise, arising from use of program and related material or any part thereof.

**FUEL LIQUIDS**

Field gases, well head gases, and associated gases typically contain liquid water and heavy hydrocarbons entrained in the gas. To prevent detonation and severe damage to the engine, hydrocarbon liquids must not be allowed to enter the engine fuel system. To remove liquids, a liquid separator and coalescing filter are recommended, with an automatic drain and collection tank to prevent contamination of the ground in accordance with local codes and standards.

To avoid water condensation in the engine or fuel lines, limit the relative humidity of water in the fuel to 80% at the minimum fuel operating temperature.

GAS COMPRESSION APPLICATION

ENGINE SPEED (rpm):	1000	RATING STRATEGY:	STANDARD
COMPRESSION RATIO:	7.6	FUEL SYSTEM:	GAV
AFTERCOOLER TYPE:	SCAC	<b>SITE CONDITIONS:</b>	WITH AIR FUEL RATIO CONTROL
AFTERCOOLER - STAGE 2 INLET (°F):	130	FUEL:	BEU DI 4 Bat Inlet Sep Gas
AFTERCOOLER - STAGE 1 INLET (°F):	174	FUEL PRESSURE RANGE (psig): (See note 1)	58.0-70.3
JACKET WATER OUTLET (°F):	190	FUEL METHANE NUMBER:	48.1
ASPIRATION:	TA	FUEL LHV (Btu/scf):	1126
COOLING SYSTEM:	JW+1AC, OC+2AC	ALTITUDE(ft):	3502
CONTROL SYSTEM:	ADEM4	INLET AIR TEMPERATURE(°F):	77
EXHAUST MANIFOLD:	DRY	STANDARD RATED POWER:	5000 bhp@1000rpm
COMBUSTION:	LOW EMISSION		
NOx EMISSION LEVEL (g/bhp-hr NOx):	0.3		
SET POINT TIMING:	16		

RATING	NOTES	LOAD	MAXIMUM RATING		SITE RATING AT MAXIMUM INLET AIR TEMPERATURE		
			100%	100%	75%	50%	
ENGINE POWER (WITHOUT FAN)	(2)	bhp	5000	5000	3750	2500	
INLET AIR TEMPERATURE		°F	77	77	77	77	

ENGINE DATA							
FUEL CONSUMPTION (LHV)		(3)	Btu/bhp-hr	6783	6783	6951	7415
FUEL CONSUMPTION (HHV)		(3)	Btu/bhp-hr	7476	7476	7661	8173
AIR FLOW (@inlet air temp, 14.7 psia)	(WET)	(4)(5)	ft3/min	12542	12542	9468	6445
AIR FLOW	(WET)	(4)(5)	lb/hr	55614	55614	41981	28579
FUEL FLOW (60°F, 14.7 psia)			scfm	502	502	386	274
INLET MANIFOLD PRESSURE		(6)	in Hg(abs)	108.6	108.6	81.1	56.6
EXHAUST TEMPERATURE - ENGINE OUTLET		(7)	°F	805	805	851	916
EXHAUST GAS FLOW (@engine outlet temp, 14.5 psia)	(WET)	(8)(5)	ft3/min	31404	31404	24582	17603
EXHAUST GAS MASS FLOW	(WET)	(8)(5)	lb/hr	57302	57302	43278	29502

EMISSIONS DATA - ENGINE OUT							
NOx (as NO2)		(9)(10)	g/bhp-hr	0.30	0.30	0.30	0.30
CO		(9)(10)	g/bhp-hr	3.06	3.06	3.06	3.07
THC (mol. wt. of 15.84)		(9)(10)	g/bhp-hr	3.59	3.59	3.93	4.17
NMHC (mol. wt. of 15.84)		(9)(10)	g/bhp-hr	1.45	1.45	1.59	1.69
NMNEHC (VOCs) (mol. wt. of 15.84)		(9)(10)(11)	g/bhp-hr	0.87	0.87	0.95	1.01
HCHO (Formaldehyde)		(9)(10)	g/bhp-hr	0.15	0.15	0.16	0.20
CO2		(9)(10)	g/bhp-hr	455	455	473	500
EXHAUST OXYGEN		(9)(12)	% DRY	11.2	11.2	10.9	10.6

HEAT REJECTION							
HEAT REJ. TO JACKET WATER (JW)		(13)	Btu/min	53193	53193	43314	36619
HEAT REJ. TO ATMOSPHERE		(13)	Btu/min	18158	18158	17058	15595
HEAT REJ. TO LUBE OIL (OC)		(13)	Btu/min	30493	30493	27342	24076
HEAT REJ. TO A/C - STAGE 1 (1AC)		(13)(14)	Btu/min	54824	54824	28621	8232
HEAT REJ. TO A/C - STAGE 2 (2AC)		(13)(14)	Btu/min	11970	11970	8316	5067

COOLING SYSTEM SIZING CRITERIA							
TOTAL JACKET WATER CIRCUIT (JW+1AC)		(14)(15)	Btu/min	116078			
TOTAL STAGE 2 AFTERCOOLER CIRCUIT (OC+2AC)		(14)(15)	Btu/min	49160			

A cooling system safety factor of 0% has been added to the cooling system sizing criteria.

**CONDITIONS AND DEFINITIONS**  
 Engine rating obtained and presented in accordance with ISO 3046/1, adjusted for fuel, site altitude and site inlet air temperature. 100% rating at maximum inlet air temperature is the maximum engine capability for the specified fuel at site altitude and maximum site inlet air temperature. Maximum rating is the maximum capability at the specified aftercooler inlet temperature for the specified fuel at site altitude and reduced inlet air temperature. Lowest load point is the lowest continuous duty operating load allowed. No overload permitted at rating shown.

For notes information consult page three.

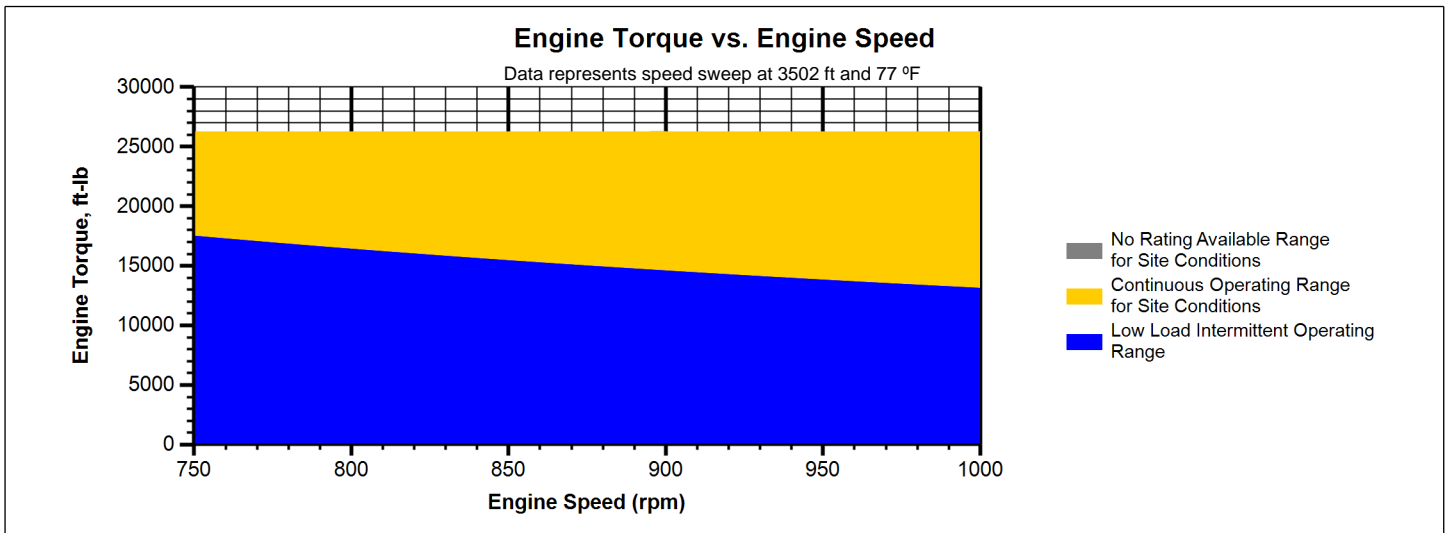
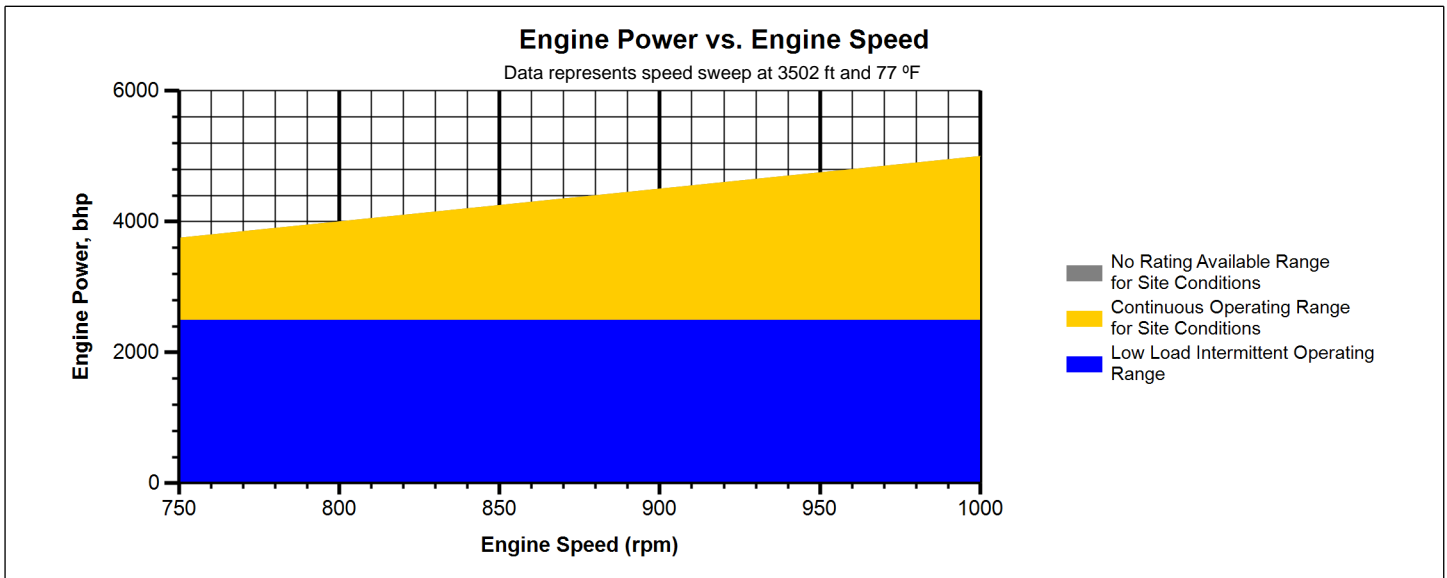
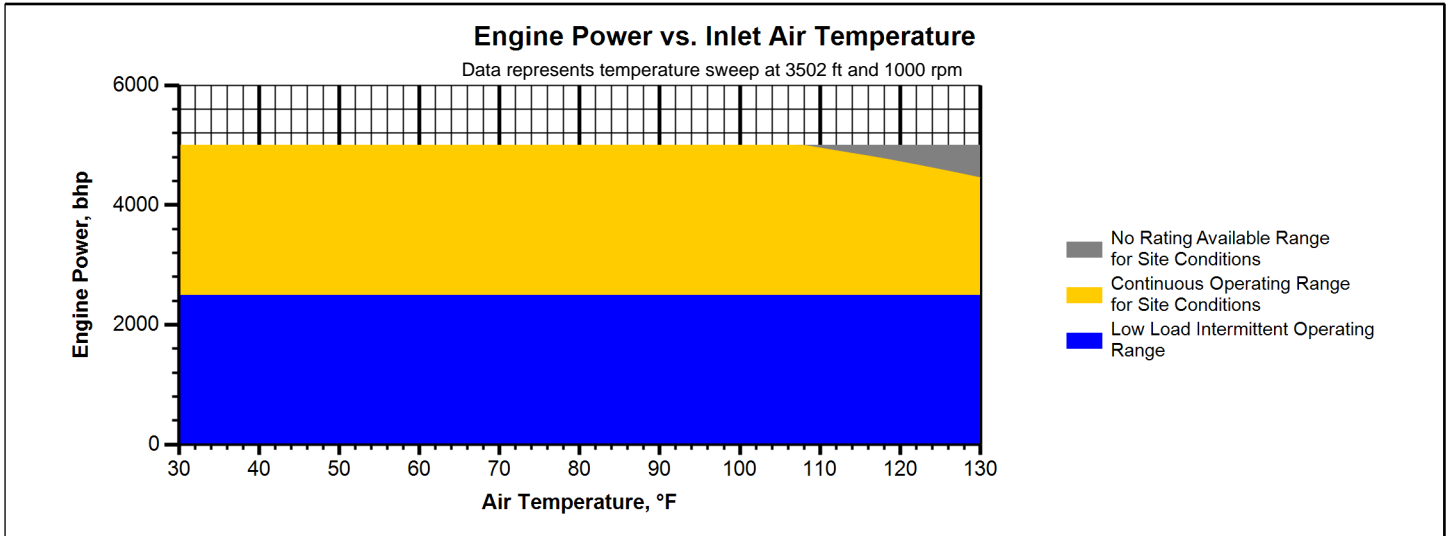

**Note:**

At site conditions of 3502 ft and 77°F inlet air temp., constant torque can be maintained down to 750 rpm. The minimum speed for loading at these conditions is 750 rpm.

**NOTES:**

1. Fuel pressure range specified is to the engine gas shutoff valve (GSOV). Additional fuel train components should be considered in pressure and flow calculations.
2. Engine rating is with two engine driven water pumps. Tolerance is  $\pm 3\%$  of full load.
3. Engine rating obtained and presented in accordance with ISO 3046/1, adjusted for fuel, site altitude and site ambient temperature.
4. Air flow value is on a 'wet' basis. Flow is a nominal value with a tolerance of  $\pm 5\%$ .
5. Inlet and Exhaust Restrictions must not exceed A&I limits based on full load flow rates from the standard technical data sheet.
6. Inlet manifold pressure is a nominal value with a tolerance of  $\pm 5\%$ .
7. Exhaust temperature is a nominal value with a tolerance of (+)63°F, (-)54°F.
8. Exhaust flow value is on a "wet" basis. Flow is a nominal value with a tolerance of  $\pm 6\%$ .
9. Emissions data is at engine exhaust flange prior to any after treatment.
10. Values listed are higher than nominal levels to allow for instrumentation, measurement, and engine-to-engine variations. They indicate the maximum values expected under steady state conditions. Fuel methane number cannot vary more than  $\pm 3$ . THC, NMHC, and NMNEHC do not include aldehydes. An oxidation catalyst may be required to meet Federal, State or local CO or HC requirements.
11. VOCs - Volatile organic compounds as defined in US EPA 40 CFR 60, subpart JJJJ
12. Exhaust Oxygen level is the result of adjusting the engine to operate at the specified NOx level. Tolerance is  $\pm 0.5$ .
13. Heat rejection values are nominal. Tolerances, based on treated water, are  $\pm 10\%$  for jacket water circuit,  $\pm 50\%$  for radiation,  $\pm 20\%$  for lube oil circuit, and  $\pm 5\%$  for aftercooler circuit.
14. Aftercooler heat rejection includes an aftercooler heat rejection factor for the site elevation and inlet air temperature specified. Aftercooler heat rejection values at part load are for reference only. Do not use part load data for heat exchanger sizing.
15. Cooling system sizing criteria are maximum circuit heat rejection for the site, with applied tolerances.

GAS COMPRESSION APPLICATION

Constituent	Abbrev	Mole %	Norm
Water Vapor	H2O	0.0000	0.0000
Methane	CH4	78.0190	78.0190
Ethane	C2H6	10.6670	10.6670
Propane	C3H8	4.8170	4.8170
Isobutane	iso-C4H10	0.5560	0.5560
Norbutane	nor-C4H10	1.4030	1.4030
Isopentane	iso-C5H12	0.3190	0.3190
Norpentane	nor-C5H12	0.3610	0.3610
Hexane	C6H14	0.3720	0.3720
Heptane	C7H16	0.5440	0.5440
Nitrogen	N2	2.0010	2.0010
Carbon Dioxide	CO2	0.9410	0.9410
Hydrogen Sulfide	H2S	0.0000	0.0000
Carbon Monoxide	CO	0.0000	0.0000
Hydrogen	H2	0.0000	0.0000
Oxygen	O2	0.0000	0.0000
Helium	HE	0.0000	0.0000
Neopentane	neo-C5H12	0.0000	0.0000
Octane	C8H18	0.0000	0.0000
Nonane	C9H20	0.0000	0.0000
Ethylene	C2H4	0.0000	0.0000
Propylene	C3H6	0.0000	0.0000
TOTAL (Volume %)		100.0000	100.0000

Fuel Makeup: BEU DI 4 Bat Inlet Sep Gas  
Unit of Measure: English

**Calculated Fuel Properties**

Caterpillar Methane Number:	48.1
Lower Heating Value (Btu/scf):	1126
Higher Heating Value (Btu/scf):	1241
WOBBE Index (Btu/scf):	1313
THC: Free Inert Ratio:	32.99
Total % Inerts (% N2, CO2, He):	2.942%
RPC (%) (To 905 Btu/scf Fuel):	100%
Compressibility Factor:	0.996
Stoich A/F Ratio (Vol/Vol):	11.68
Stoich A/F Ratio (Mass/Mass):	15.87
Specific Gravity (Relative to Air):	0.736
Fuel Specific Heat Ratio (K):	1.285

**CONDITIONS AND DEFINITIONS**

Caterpillar Methane Number represents the knock resistance of a gaseous fuel. It should be used with the Caterpillar Fuel Usage Guide for the engine and rating to determine the rating for the fuel specified. A Fuel Usage Guide for each rating is included on page 2 of its standard technical data sheet.

RPC always applies to naturally aspirated (NA) engines, and turbocharged (TA or LE) engines only when they are derated for altitude and ambient site conditions.

Project specific technical data sheets generated by the Caterpillar Gas Engine Rating Pro program take the Caterpillar Methane Number and RPC into account when generating a site rating.

Fuel properties for Btu/scf calculations are at 60F and 14.696 psia.

Caterpillar shall have no liability in law or equity, for damages, consequently or otherwise, arising from use of program and related material or any part thereof.

**FUEL LIQUIDS**

Field gases, well head gases, and associated gases typically contain liquid water and heavy hydrocarbons entrained in the gas. To prevent detonation and severe damage to the engine, hydrocarbon liquids must not be allowed to enter the engine fuel system. To remove liquids, a liquid separator and coalescing filter are recommended, with an automatic drain and collection tank to prevent contamination of the ground in accordance with local codes and standards.

To avoid water condensation in the engine or fuel lines, limit the relative humidity of water in the fuel to 80% at the minimum fuel operating temperature.



Power Emission Group  
 311 Riggs Street, Bloomer, WI 54724  
 Tel: (715) 568-2882 • Fax: (715)568-2884  
 Email bweninger@catalyticcombustion.com



To XTO  
 Attn Ben  
 Via E-mail

Our Ref. 001-00-268588.00  
 Date: 09 July, 2020  
 Page: 1 of 2

Catalyst Performance

For : Project/Location : Bulldog

**Engine Parameters**

Engine Manufacturer	Caterpillar			Raw Exhaust
Engine Model	G3616		NOx	0.30 g/bhp-hr
Horsepower	5000	bhp	CO	3.06 g/bhp-hr
Speed	1000	rpm	NMHC	1.45 g/bhp-hr
Exhaust Flowrate	31404	acfm	NMNEHC (VOC)	0.87 g/bhp-hr
Exhaust Temperature	805	° F	HCHO	0.15 g/bhp-hr
Fuel	Natural Gas		Oxygen	11.20 %

**Catalyst Description and Performance Expectations**

Catalyst Model	RGTB-2516F-D-20HF-HFX4	Overall Dimensions	24.75 x 15.44 x 3.7
Cell Pattern, Substrate	20HF	Catalyst Qty Required	12 per Unit
Formulation	HFX4	Pressure Drop	3.9 inches of H2O
Warranty Period [hrs]	8000		

Performance

NOx		
CO	88	% Conversion
NMHC		
NMNEHC (VOC)	65	% Conversion
HCHO	74	% Conversion

General Terms and Conditions of Sale and Manufacturers Warranty documents are available upon request.

Please contact us if you have any questions or to let us know how we can be of further help.

Best regards,

Brian Weninger

Product and Application Engineer, Power Emission Group

Power Emission Group  
 311 Riggs Street, Bloomer, WI 54724  
 Tel: (715) 568-2882 • Fax: (715)568-2884  
 Email bweninger@catalyticcombustion.com



To XTO  
 Attn Ben  
 Via E-mail

Our Ref. 001-00-268588.00  
 Date: 09 July, 2020  
 Page: 2 of 2

Catalyst Performance

For : Project/Location : Bulldog

**Engine Parameters**

Engine Manufacturer	Caterpillar			Raw Exhaust
Engine Model	G3516J		NOx	0.50 g/bhp-hr
Horsepower	1380	bhp	CO	2.55 g/bhp-hr
Speed	1400	rpm	NMHC	1.52 g/bhp-hr
Exhaust Flowrate	8108	acfm	NMNEHC (VOC)	0.91 g/bhp-hr
Exhaust Temperature	837	° F	HCHO	0.36 g/bhp-hr
Fuel	Natural Gas		Oxygen	9.10 %

**Catalyst Description and Performance Expectations**

Catalyst Model	RGTB-2516F-D-20HF-HFX4	Overall Dimensions	24.75 x 15.44 x 3.7
Cell Pattern, Substrate	20HF	Catalyst Qty Required	3 per Unit
Formulation	HFX4	Pressure Drop	4.1 inches of H2O
Warranty Period [hrs]	16000		

Performance

NOx		
CO	88	% Conversion
NMHC		
NMNEHC (VOC)	65	% Conversion
HCHO	74	% Conversion

General Terms and Conditions of Sale and Manufacturers Warranty documents are available upon request.

Please contact us if you have any questions or to let us know how we can be of further help.

Best regards,

Brian Weninger  
 Product and Application Engineer, Power Emission Group

Table 1.4-1. EMISSION FACTORS FOR NITROGEN OXIDES (NO<sub>x</sub>) AND CARBON MONOXIDE (CO)  
FROM NATURAL GAS COMBUSTION<sup>a</sup>

Combustor Type (MMBtu/hr Heat Input) [SCC]	NO <sub>x</sub> <sup>b</sup>		CO	
	Emission Factor (lb/10 <sup>6</sup> scf)	Emission Factor Rating	Emission Factor (lb/10 <sup>6</sup> scf)	Emission Factor Rating
Large Wall-Fired Boilers (>100) [1-01-006-01, 1-02-006-01, 1-03-006-01]				
Uncontrolled (Pre-NSPS) <sup>c</sup>	280	A	84	B
Uncontrolled (Post-NSPS) <sup>c</sup>	190	A	84	B
Controlled - Low NO <sub>x</sub> burners	140	A	84	B
Controlled - Flue gas recirculation	100	D	84	B
Small Boilers (<100) [1-01-006-02, 1-02-006-02, 1-03-006-02, 1-03-006-03]				
Uncontrolled	100	B	84	B
Controlled - Low NO <sub>x</sub> burners	50	D	84	B
Controlled - Low NO <sub>x</sub> burners/Flue gas recirculation	32	C	84	B
Tangential-Fired Boilers (All Sizes) [1-01-006-04]				
Uncontrolled	170	A	24	C
Controlled - Flue gas recirculation	76	D	98	D
Residential Furnaces (<0.3) [No SCC]				
Uncontrolled	94	B	40	B

<sup>a</sup> Reference 11. Units are in pounds of pollutant per million standard cubic feet of natural gas fired. To convert from lb/10<sup>6</sup> scf to kg/10<sup>6</sup> m<sup>3</sup>, multiply by 16. Emission factors are based on an average natural gas higher heating value of 1,020 Btu/scf. To convert from lb/10<sup>6</sup> scf to lb/MMBtu, divide by 1,020. The emission factors in this table may be converted to other natural gas heating values by multiplying the given emission factor by the ratio of the specified heating value to this average heating value. SCC = Source Classification Code. ND = no data. NA = not applicable.

<sup>b</sup> Expressed as NO<sub>2</sub>. For large and small wall fired boilers with SNCR control, apply a 24 percent reduction to the appropriate NO<sub>x</sub> emission factor. For tangential-fired boilers with SNCR control, apply a 13 percent reduction to the appropriate NO<sub>x</sub> emission factor.

<sup>c</sup> NSPS=New Source Performance Standard as defined in 40 CFR 60 Subparts D and Db. Post-NSPS units are boilers with greater than 250 MMBtu/hr of heat input that commenced construction modification, or reconstruction after August 17, 1971, and units with heat input capacities between 100 and 250 MMBtu/hr that commenced construction modification, or reconstruction after June 19, 1984.

TABLE 1.4-2. EMISSION FACTORS FOR CRITERIA POLLUTANTS AND GREENHOUSE GASES FROM NATURAL GAS COMBUSTION<sup>a</sup>

Pollutant	Emission Factor (lb/10 <sup>6</sup> scf)	Emission Factor Rating
CO <sub>2</sub> <sup>b</sup>	120,000	A
Lead	0.0005	D
N <sub>2</sub> O (Uncontrolled)	2.2	E
N <sub>2</sub> O (Controlled-low-NO <sub>x</sub> burner)	0.64	E
PM (Total) <sup>c</sup>	7.6	D
PM (Condensable) <sup>c</sup>	5.7	D
PM (Filterable) <sup>c</sup>	1.9	B
SO <sub>2</sub> <sup>d</sup>	0.6	A
TOC	11	B
Methane	2.3	B
VOC	5.5	C

<sup>a</sup> Reference 11. Units are in pounds of pollutant per million standard cubic feet of natural gas fired. Data are for all natural gas combustion sources. To convert from lb/10<sup>6</sup> scf to kg/10<sup>6</sup> m<sup>3</sup>, multiply by 16. To convert from lb/10<sup>6</sup> scf to lb/MMBtu, divide by 1,020. The emission factors in this table may be converted to other natural gas heating values by multiplying the given emission factor by the ratio of the specified heating value to this average heating value. TOC = Total Organic Compounds.

VOC = Volatile Organic Compounds.

<sup>b</sup> Based on approximately 100% conversion of fuel carbon to CO<sub>2</sub>. CO<sub>2</sub>[lb/10<sup>6</sup> scf] = (3.67) (CON) (C)(D), where CON = fractional conversion of fuel carbon to CO<sub>2</sub>, C = carbon content of fuel by weight (0.76), and D = density of fuel, 4.2x10<sup>4</sup> lb/10<sup>6</sup> scf.

<sup>c</sup> All PM (total, condensable, and filterable) is assumed to be less than 1.0 micrometer in diameter. Therefore, the PM emission factors presented here may be used to estimate PM<sub>10</sub>, PM<sub>2.5</sub> or PM<sub>1</sub> emissions. Total PM is the sum of the filterable PM and condensable PM. Condensable PM is the particulate matter collected using EPA Method 202 (or equivalent). Filterable PM is the particulate matter collected on, or prior to, the filter of an EPA Method 5 (or equivalent) sampling train.

<sup>d</sup> Based on 100% conversion of fuel sulfur to SO<sub>2</sub>.

Assumes sulfur content is natural gas of 2,000 grains/10<sup>6</sup> scf. The SO<sub>2</sub> emission factor in this table can be converted to other natural gas sulfur contents by multiplying the SO<sub>2</sub> emission factor by the ratio of the site-specific sulfur content (grains/10<sup>6</sup> scf) to 2,000 grains/10<sup>6</sup> scf.

TABLE 1.4-3. EMISSION FACTORS FOR SPECIATED ORGANIC COMPOUNDS FROM NATURAL GAS COMBUSTION<sup>a</sup>

CAS No.	Pollutant	Emission Factor (lb/10 <sup>6</sup> scf)	Emission Factor Rating
91-57-6	2-Methylnaphthalene <sup>b,c</sup>	2.4E-05	D
56-49-5	3-Methylchloranthrene <sup>b,c</sup>	<1.8E-06	E
	7,12-Dimethylbenz(a)anthracene <sup>b,c</sup>	<1.6E-05	E
83-32-9	Acenaphthene <sup>b,c</sup>	<1.8E-06	E
203-96-8	Acenaphthylene <sup>b,c</sup>	<1.8E-06	E
120-12-7	Anthracene <sup>b,c</sup>	<2.4E-06	E
56-55-3	Benz(a)anthracene <sup>b,c</sup>	<1.8E-06	E
71-43-2	Benzene <sup>b</sup>	2.1E-03	B
50-32-8	Benzo(a)pyrene <sup>b,c</sup>	<1.2E-06	E
205-99-2	Benzo(b)fluoranthene <sup>b,c</sup>	<1.8E-06	E
191-24-2	Benzo(g,h,i)perylene <sup>b,c</sup>	<1.2E-06	E
205-82-3	Benzo(k)fluoranthene <sup>b,c</sup>	<1.8E-06	E
106-97-8	Butane	2.1E+00	E
218-01-9	Chrysene <sup>b,c</sup>	<1.8E-06	E
53-70-3	Dibenzo(a,h)anthracene <sup>b,c</sup>	<1.2E-06	E
25321-22-6	Dichlorobenzene <sup>b</sup>	1.2E-03	E
74-84-0	Ethane	3.1E+00	E
206-44-0	Fluoranthene <sup>b,c</sup>	3.0E-06	E
86-73-7	Fluorene <sup>b,c</sup>	2.8E-06	E
50-00-0	Formaldehyde <sup>b</sup>	7.5E-02	B
110-54-3	Hexane <sup>b</sup>	1.8E+00	E
193-39-5	Indeno(1,2,3-cd)pyrene <sup>b,c</sup>	<1.8E-06	E
91-20-3	Naphthalene <sup>b</sup>	6.1E-04	E
109-66-0	Pentane	2.6E+00	E
85-01-8	Phenanathrene <sup>b,c</sup>	1.7E-05	D

TABLE 1.4-3. EMISSION FACTORS FOR SPECIATED ORGANIC COMPOUNDS FROM NATURAL GAS COMBUSTION (Continued)

CAS No.	Pollutant	Emission Factor (lb/10 <sup>6</sup> scf)	Emission Factor Rating
74-98-6	Propane	1.6E+00	E
129-00-0	Pyrene <sup>b, c</sup>	5.0E-06	E
108-88-3	Toluene <sup>b</sup>	3.4E-03	C

<sup>a</sup> Reference 11. Units are in pounds of pollutant per million standard cubic feet of natural gas fired. Data are for all natural gas combustion sources. To convert from lb/10<sup>6</sup> scf to kg/10<sup>6</sup> m<sup>3</sup>, multiply by 16. To convert from lb/10<sup>6</sup> scf to lb/MMBtu, divide by 1,020. Emission Factors preceded with a less-than symbol are based on method detection limits.

<sup>b</sup> Hazardous Air Pollutant (HAP) as defined by Section 112(b) of the Clean Air Act.

<sup>c</sup> HAP because it is Polycyclic Organic Matter (POM). POM is a HAP as defined by Section 112(b) of the Clean Air Act.

<sup>d</sup> The sum of individual organic compounds may exceed the VOC and TOC emission factors due to differences in test methods and the availability of test data for each pollutant.

Table 3.2-2. UNCONTROLLED EMISSION FACTORS FOR 4-STROKE LEAN-BURN ENGINES<sup>a</sup>  
(SCC 2-02-002-54)

Pollutant	Emission Factor (lb/MMBtu) <sup>b</sup> (fuel input)	Emission Factor Rating
Criteria Pollutants and Greenhouse Gases		
NO <sub>x</sub> <sup>c</sup> 90 - 105% Load	4.08 E+00	B
NO <sub>x</sub> <sup>c</sup> <90% Load	8.47 E-01	B
CO <sup>c</sup> 90 - 105% Load	3.17 E-01	C
CO <sup>c</sup> <90% Load	5.57 E-01	B
CO <sub>2</sub> <sup>d</sup>	1.10 E+02	A
SO <sub>2</sub> <sup>e</sup>	5.88 E-04	A
TOC <sup>f</sup>	1.47 E+00	A
Methane <sup>g</sup>	1.25 E+00	C
VOC <sup>h</sup>	1.18 E-01	C
PM10 (filterable) <sup>i</sup>	7.71 E-05	D
PM2.5 (filterable) <sup>i</sup>	7.71 E-05	D
PM Condensable <sup>j</sup>	9.91 E-03	D
Trace Organic Compounds		
1,1,2,2-Tetrachloroethane <sup>k</sup>	<4.00 E-05	E
1,1,2-Trichloroethane <sup>k</sup>	<3.18 E-05	E
1,1-Dichloroethane	<2.36 E-05	E
1,2,3-Trimethylbenzene	2.30 E-05	D
1,2,4-Trimethylbenzene	1.43 E-05	C
1,2-Dichloroethane	<2.36 E-05	E
1,2-Dichloropropane	<2.69 E-05	E
1,3,5-Trimethylbenzene	3.38 E-05	D
1,3-Butadiene <sup>k</sup>	2.67E-04	D
1,3-Dichloropropene <sup>k</sup>	<2.64 E-05	E
2-Methylnaphthalene <sup>k</sup>	3.32 E-05	C
2,2,4-Trimethylpentane <sup>k</sup>	2.50 E-04	C
Acenaphthene <sup>k</sup>	1.25 E-06	C

Table 3.2-2. UNCONTROLLED EMISSION FACTORS FOR 4-STROKE LEAN-BURN ENGINES  
(Continued)

Pollutant	Emission Factor (lb/MMBtu) <sup>b</sup> (fuel input)	Emission Factor Rating
Acenaphthylene <sup>k</sup>	5.53 E-06	C
Acetaldehyde <sup>k,l</sup>	8.36 E-03	A
Acrolein <sup>k,l</sup>	5.14 E-03	A
Benzene <sup>k</sup>	4.40 E-04	A
Benzo(b)fluoranthene <sup>k</sup>	1.66 E-07	D
Benzo(e)pyrene <sup>k</sup>	4.15 E-07	D
Benzo(g,h,i)perylene <sup>k</sup>	4.14 E-07	D
Biphenyl <sup>k</sup>	2.12 E-04	D
Butane	5.41 E-04	D
Butyr/Isobutyraldehyde	1.01 E-04	C
Carbon Tetrachloride <sup>k</sup>	<3.67 E-05	E
Chlorobenzene <sup>k</sup>	<3.04 E-05	E
Chloroethane	1.87 E-06	D
Chloroform <sup>k</sup>	<2.85 E-05	E
Chrysene <sup>k</sup>	6.93 E-07	C
Cyclopentane	2.27 E-04	C
Ethane	1.05 E-01	C
Ethylbenzene <sup>k</sup>	3.97 E-05	B
Ethylene Dibromide <sup>k</sup>	<4.43 E-05	E
Fluoranthene <sup>k</sup>	1.11 E-06	C
Fluorene <sup>k</sup>	5.67 E-06	C
Formaldehyde <sup>k,l</sup>	5.28 E-02	A
Methanol <sup>k</sup>	2.50 E-03	B
Methylcyclohexane	1.23 E-03	C
Methylene Chloride <sup>k</sup>	2.00 E-05	C
n-Hexane <sup>k</sup>	1.11 E-03	C
n-Nonane	1.10 E-04	C



# Section 8

## Map(s)

---

**A map** such as a 7.5 minute topographic quadrangle showing the exact location of the source. The map shall also include the following:

The UTM or Longitudinal coordinate system on both axes	An indicator showing which direction is north
A minimum radius around the plant of 0.8km (0.5 miles)	Access and haul roads
Topographic features of the area	Facility property boundaries
The name of the map	The area which will be restricted to public access
A graphical scale	

---

A site location map and aerial image illustrating the property boundary and surrounding access roads is provided.



U.S. DEPARTMENT OF THE INTERIOR  
U.S. GEOLOGICAL SURVEY



WILLIAMS SINK QUADRANGLE  
NEW MEXICO  
7.5-MINUTE SERIES

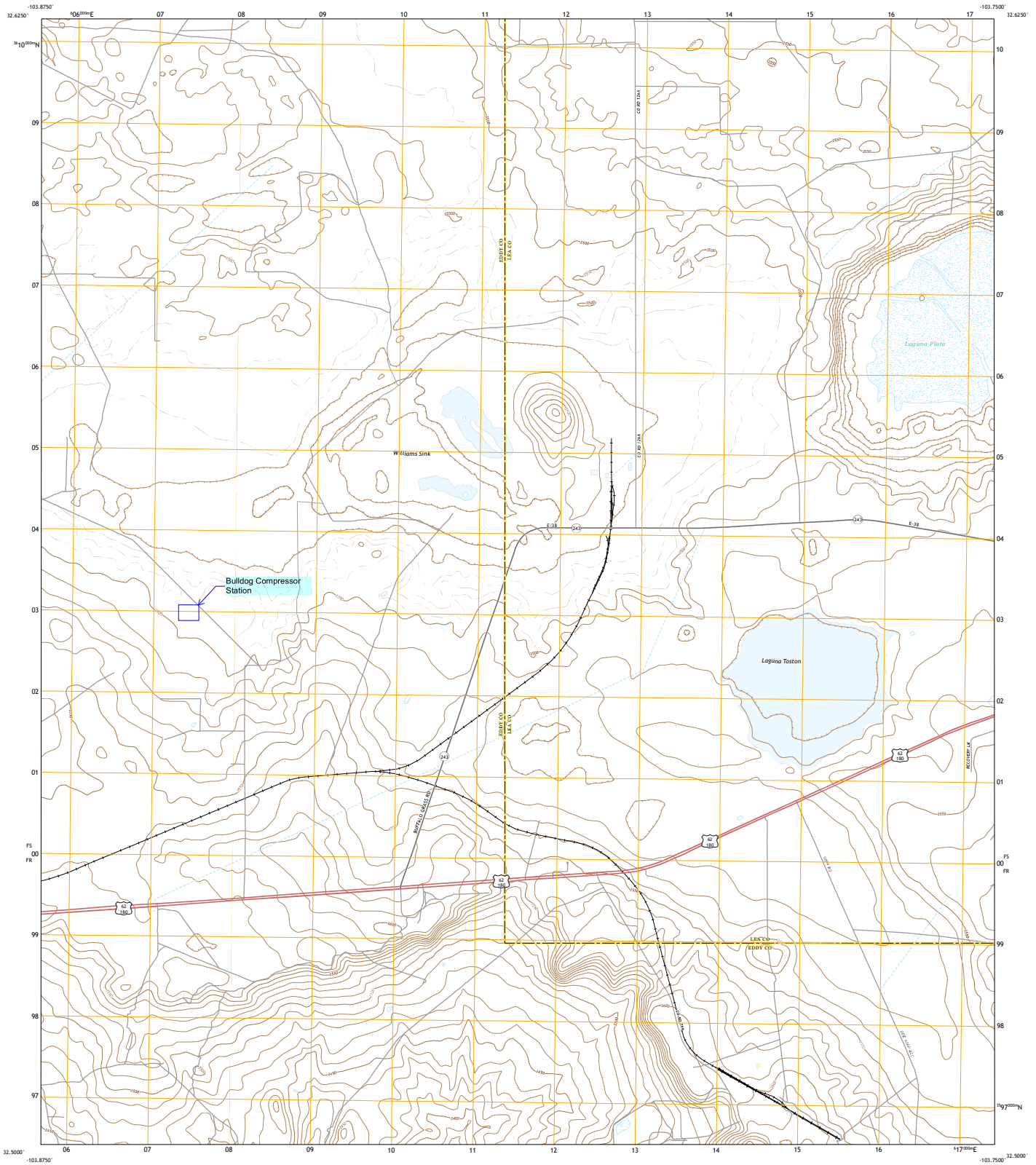

Produced by the United States Geological Survey  
North American Datum of 1983 (NAD83)  
World Geodetic System of 1984 (WGS84), Projection and  
1 000-meter grid interval Transverse Mercator, Zone 13S  
This map is not a legal document. Boundaries may be  
generalized for this map scale. Private lands with government  
reservations may not be shown. Obtain permission before  
entering private lands.

Inventory: .....NAP, May 2016, August 2016  
Roads: .....U.S. Census Bureau, 2016  
Names: .....GNIS, 1980  
Hydrography: .....National Hydrography Dataset, 2002, 2018  
Contours: .....National Elevation Dataset, 2002  
Boundaries: .....Multiple sources; see metadata file 2017\_2018  
Public Land Survey System: .....BLM, 2019  
Wetlands: .....FWS National Wetlands Inventory, Not Available

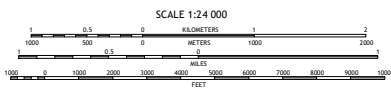
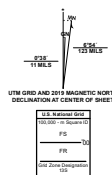

1	2	3
4	5	6
7	8	9

Adjacent quadrangles

ROAD CLASSIFICATION

Expressway	Local Connector
Secondary Hwy	Local Road
Route	AMP
Interstate Route	US Route
	State Route

CONTOUR INTERVAL 10 FEET  
NORTH AMERICAN DATUM OF 1983  
This map was produced in conformance with the  
National Geospatial Program US Topo Product Standard, 2011.  
A metadata file associated with this product is draft version 0.6.18

WILLIAMS SINK, NM  
2020

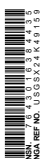

**Tab 9**  
**Section 9 - Proof of Public Notice**

**Item 1.**

**Certified Mail Receipts with Postmarks**

**DEPARTMENT (XTO)**  
**CONTACT: Benjamin Schneider**  
**LOCATION: W4.6B.374**  
**PHONE: 832 624-2768**  
**SPRING, TX 77389**

**CERTIFIED MAIL**

LINE	ARTICLE NUMBER	NAME OF ADDRESSEE	Description	POSTAGE	Certified Fee/Registered Fee	Return Fee
1	7018 1130 0002 2476 2604 ✓	Bureau of Land Management 620 E. Greene St. Carlsbad, New Mexico, 88220-6292	Bulldog/Longhorn/Jayhawk Notification of NSR Permit Application	6.105	3.55	2.85
2	7018 1130 0002 2476 2611 ✓	Eddy County Manager 101 W. Greene St. Suite 110 Carlsbad, New Mexico, 88220	Bulldog/Longhorn/Jayhawk Notification of NSR Permit Application			
3	7018 1130 0002 2476 2628 ✓	Lea County Manager 100 N. Main Avenue Suite 4 Lovington, New Mexico, 88260	Bulldog/Longhorn/Jayhawk Notification of NSR Permit Application			
4	7018 1130 0002 2476 2635 ✓	State of New Mexico Land Office 310 Old Santa Fe Trail Santa Fe, New Mexico, 87501	Bulldog/Longhorn/Jayhawk Notification of NSR Permit Application			

**Mail Center: Please have this form stamped by the Post Office**

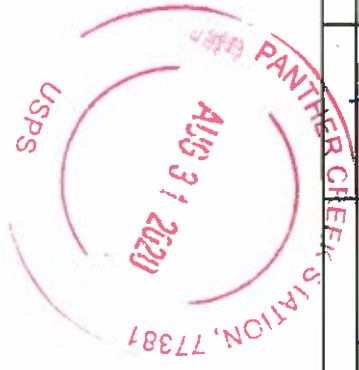

Mail Center : Please have this form date stamped by the Post Office.

U.S. Postal Service™  
CERTIFIED MAIL® RECEIPT  
Domestic Mail Only

OFFICIAL USE

7018 1130 0002 2476 2604

7018 1130 0002 2476 2604

Bureau of Land Management  
601 E. Greene St.  
Carlsbad, New Mexico 88220-6092

U.S. Postal Service™  
CERTIFIED MAIL® RECEIPT  
Domestic Mail Only

OFFICIAL USE

7018 1130 0002 2476 2611

7018 1130 0002 2476 2611

State of New Mexico Land Office  
310 Old Santa Fe Trail  
Santa Fe, New Mexico, 87501

State  
310 C  
Santa

U.S. Postal Service™  
CERTIFIED MAIL® RECEIPT  
Domestic Mail Only

OFFICIAL USE

7018 1130 0002 2476 2611

7018 1130 0002 2476 2611

Eddy County Manager  
101 W. Greene St.  
Suite 110  
Carlsbad, New Mexico 88220

U.S. Postal Service™  
CERTIFIED MAIL® RECEIPT  
Domestic Mail Only

OFFICIAL USE

7018 1130 0002 2476 2628

7018 1130 0002 2476 2628

Las County Manager  
100 N. Main Avenue  
Suite 4  
Longhorn, New Mexico 88200

DEPARTMENT (XTO)  
CONTACT: Benjamin Schneider  
LOCATION: WA68374  
PHONE: 532 624-2768  
SPRING, TX 77989

CERTIFIED MAIL

LINE	ARTICLE NUMBER	NAME OF ADDRESSEE	Description	POSTAGE	Certified Postage Fee	Amount
1	7018 1130 0002 2476 2604	Bureau of Land Management 601 E. Greene St. Carlsbad, New Mexico 88220-6092	Bulding/comprom/ly/bank Notification of NSR Permit Application			
2	7018 1130 0002 2476 2611	Eddy County Manager 101 W. Greene St. Suite 110 Carlsbad, New Mexico 88220	Bulding/comprom/ly/bank Notification of NSR Permit Application			
3	7018 1130 0002 2476 2628	Las County Manager 100 N. Main Avenue Suite 4 Longhorn, New Mexico 88200	Bulding/comprom/ly/bank Notification of NSR Permit Application			
4	7018 1130 0002 2476 2635	State of New Mexico Land Office 310 Old Santa Fe Trail Santa Fe, New Mexico 87501	Bulding/comprom/ly/bank Notification of NSR Permit Application			

Mail Center. Please have this form stamped by the Post Office

**Item 2.**

**List of Places Posted**

Site Location

Carlsbad Post Office

Carlsbad Public Library

Hobbs Post Office

**Item 3.**

**Property Tax Records**



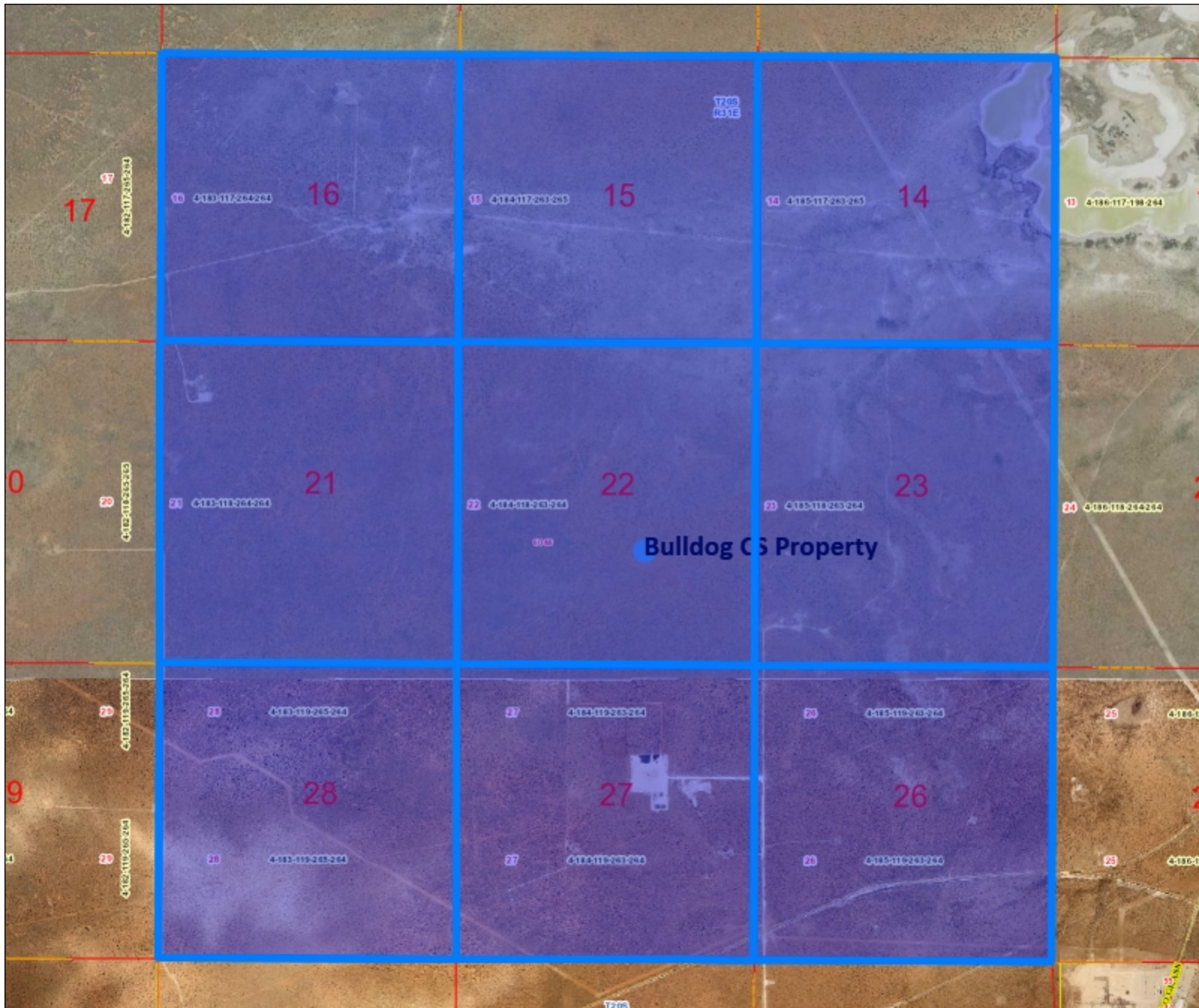

### Legend

#### Cartography

- <all other values>
- Govt Lot Lines
- Dimension Tic
- Leader Lines
- Misc Carto
- Owner Hooks
- Sub Corners
- Roads
- Railroads
- Water
- Geographic
- Section
- Subdivision
- Parcel

### Bulldog CS Property

Web Print: 07/31/2020

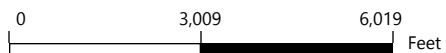

This map is a user generated static output from an Internet mapping site and is for reference only. Data layers that appear on this map may or may not be accurate, current, or otherwise reliable.





OBJECTID\_12\_13\_14: 5502  
UPC: 4-184-118-263-264  
UPC\_join: 4184118263264  
ACCOUNTNUMBER: R074779  
LEGALSUMMARY: Quarter: NE S: 22 T: 20S  
R: 31E Quarter: NW S: 22 T: 20S R: 31E  
Quarter: SW S: 22 T: 20S R: 31E Quarter: SE S:  
22 T: 20S R: 31E ALL MAP# 174-22 LOC N OF  
HWY 62-180 EXEMPT  
OWNERNAME: BUREAU OF LAND  
MANAGEMENT  
LANDACTUAL: 2880  
OBJECTID\_1: 45214  
TAXYEAR\_1: 2020  
ACCOUNTNUMBER\_1: R074779  
SEQUENCE\_R: 0  
OWNER\_OCCURENCE: 0  
INTERNALID: C20160020093.1451631600000  
DOCUMENT\_TTYPE: Owner  
ACTIVE\_1: A  
CONFIDENTIAL: 0  
OWNERID\_1: C20160020093  
OBJECTID\_12: 35982  
TAXYEAR\_12: 2020  
ACCOUNTNUMBER\_12: R074779  
SEQUENCE\_R\_1: 0  
INTERNALID\_1:  
R074779.LAND2767740.1511254989514  
MODEL\_TYPE: Land  
ACCOUNTNUMBER\_12\_13: R074779  
ACTUALAREA: 640  
LANDCODE: 141\_4\_5  
TAXAREA: CO\_NR  
VERSIONEND\_1: 9223372036854775807  
VERSIONSTART\_1: 1511254989514

This map is a user generated static output from an Internet mapping site and is for reference only. Data layers that appear on this map may or may not be accurate, current, or otherwise reliable.

# Property Record Card

Eddy Assessor

**BUREAU OF LAND  
MANAGEMENT**

**Account: R074779**

Tax Area: CO\_NR - CARLSBAD-  
OUT (Nonresidential)

Acres: 0.000

**Parcel: 4-184-118-263-264**

Situs Address:

## Value Summary

Value By:	Market	Override
Land (1)	\$2,880	N/A
<b>Total</b>	<b>\$2,880</b>	<b>\$2,880</b>

## Legal Description

Quarter: NE S: 22 T: 20S R: 31E Quarter: NW S: 22 T: 20S R: 31E  
Quarter: SW S: 22 T: 20S R: 31E Quarter: SE S: 22 T: 20S R: 31E ALL  
MAP# 174-22 LOC N OF HWY 62-180 EXEMPT

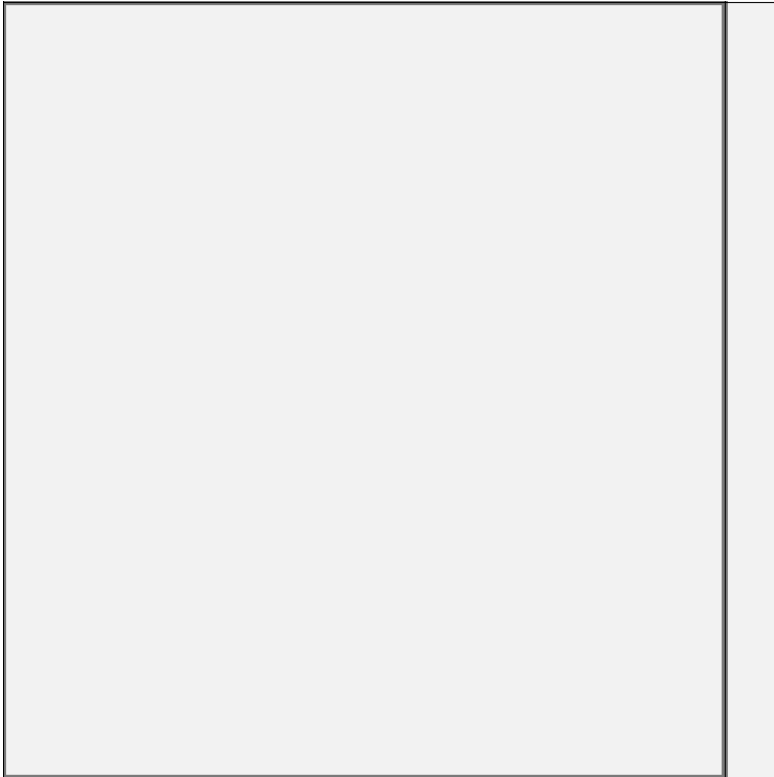

## Land Occurrence 1

Property Code 9200 - EXEMPT NON-RESIDENTIAL LAND Land Code 141\_4\_5 - Grazing E Federal - 4.5

## Abstract Summary

Code	Classification	Actual Value	Value	Taxable Value	Actual Value Override	Taxable Override
9200	EXEMPT NON-RESIDENTIAL LAND		\$2,880	\$960	NA	NA
<b>Total</b>			<b>\$2,880</b>	<b>\$960</b>	<b>NA</b>	<b>NA</b>



OBJECTID\_12\_13\_14: 5485  
UPC: 4-183-117-264-264  
UPC\_join: 4183117264264  
ACCOUNTNUMBER: R074877  
LEGALSUMMARY: Quarter: NE S: 16 T: 20S  
R: 31E Quarter: NW S: 16 T: 20S R: 31E  
Quarter: SW S: 16 T: 20S R: 31E Quarter: SE S:  
16 T: 20S R: 31E NE, NW, SW, SE LESS 6.1  
AC, 9.25 AC VALOR, 15.5 AC HWY, SW LESS  
6.1 AC 15.5 AC HWY MAP# 174-32 LOC  
EXEMPT  
OWNERNAME: STATE OF NEW MEXICO  
LANDACTUAL: 2643  
OBJECTID\_1: 45307  
TAXYEAR\_1: 2020  
ACCOUNTNUMBER\_1: R074877  
SEQUENCE\_R: 0  
OWNER\_OCCURENCE: 0  
INTERNALID: C20160020105.1451631600000  
DOCUMENT\_TTYPE: Owner  
ACTIVE\_1: A  
CONFIDENTIAL: 0  
OWNERADDRESS\_ADDRESS1: 310 OLD  
SANTA FE TRAIL  
OWNERADDRESS\_CITY: SANTA FE  
OWNERADDRESS\_STATE: NM  
OWNERADDRESS\_ZIP: 87504  
OWNERID\_1: C20160020105  
OBJECTID\_12: 36074  
TAXYEAR\_12: 2020  
ACCOUNTNUMBER\_12: R074877  
SEQUENCE\_R\_1: 0  
INTERNALID\_1:  
R074877.LAND2769433.1511255041724  
MODEL\_TYPE: Land  
ACCOUNTNUMBER\_12\_13: R074877  
ACTUALAREA: 587.55  
LANDCODE: 153\_4\_5  
TAXAREA: CO\_NR  
VERSIONEND\_1: 9223372036854775807  
VERSIONSTART\_1: 1511255041724

This map is a user generated static output from an Internet mapping site and is for reference only. Data layers that appear on this map may or may not be accurate, current, or otherwise reliable.

# Property Record Card

Eddy Assessor

**STATE OF NEW MEXICO**

310 OLD SANTA FE TRAIL  
SANTA FE, NM 87504

**Account: R074877**

Tax Area: CO\_NR - CARLSBAD-  
OUT (Nonresidential)

Acres: 0.000

**Parcel: 4-183-117-264-264**

Situs Address:

## Value Summary

Value By:	Market	Override
Land (1)	\$2,643	N/A
<b>Total</b>	<b>\$2,643</b>	<b>\$2,643</b>

## Legal Description

Quarter: NE S: 16 T: 20S R: 31E Quarter: NW S: 16 T: 20S R: 31E  
Quarter: SW S: 16 T: 20S R: 31E Quarter: SE S: 16 T: 20S R: 31E NE,  
NW, SW, SE LESS 6.1 AC, 9.25 AC VALOR, 15.5 AC HWY, SW LESS  
6.1 AC 15.5 AC HWY MAP# 174-32 LOC EXEMPT

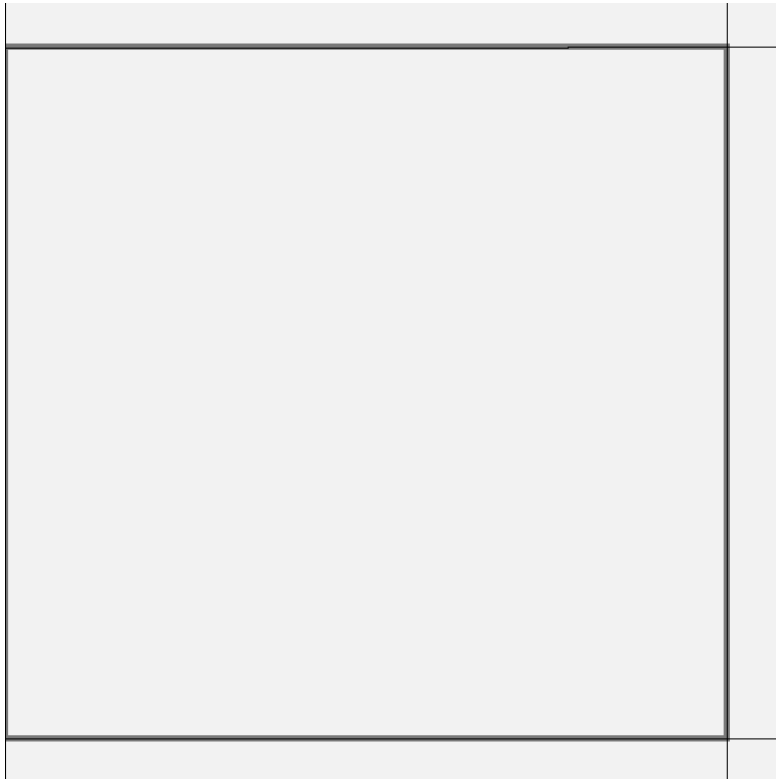

## Land Occurrence 1

Property Code	9200 - EXEMPT NON-RESIDENTIAL LAND	Land Code	153_4_5 - Grazing E NM - 4.5
---------------	---------------------------------------	-----------	------------------------------

## Abstract Summary

Code	Classification	Actual Value	Value	Taxable Value	Actual Value Override	Taxable Override
9200	EXEMPT NON-RESIDENTIAL LAND		\$2,643	\$881	NA	NA
<b>Total</b>			<b>\$2,643</b>	<b>\$881</b>	<b>NA</b>	<b>NA</b>



OBJECTID\_12\_13\_14: 5519  
UPC: 4-185-118-263-264  
UPC\_join: 4185118263264  
ACCOUNTNUMBER: R074781  
LEGALSUMMARY: Quarter: NE S: 23 T: 20S  
R: 31E Quarter: NW S: 23 T: 20S R: 31E  
Quarter: SW S: 23 T: 20S R: 31E Quarter: SE S:  
23 T: 20S R: 31E ALL MAP# 174-23 LOC W OF  
BUFFALO GRASS RD EXEMPT  
OWNERNAME: BUREAU OF LAND  
MANAGEMENT  
LANDACTUAL: 2880  
OBJECTID\_1: 45216  
TAXYEAR\_1: 2020  
ACCOUNTNUMBER\_1: R074781  
SEQUENCE\_R: 0  
OWNER\_OCCURENCE: 0  
INTERNALID: C20160020093.1451631600000  
DOCUMENT\_TTYPE: Owner  
ACTIVE\_1: A  
CONFIDENTIAL: 0  
OWNERID\_1: C20160020093  
OBJECTID\_12: 35984  
TAXYEAR\_12: 2020  
ACCOUNTNUMBER\_12: R074781  
SEQUENCE\_R\_1: 0  
INTERNALID\_1:  
R074781.LAND2767741.1511254990797  
MODEL\_TYPE: Land  
ACCOUNTNUMBER\_12\_13: R074781  
ACTUALAREA: 640  
LANDCODE: 141\_4\_5  
TAXAREA: CO\_NR  
VERSIONEND\_1: 9223372036854775807  
VERSIONSTART\_1: 1511254990797

This map is a user generated static output from an Internet mapping site and is for reference only. Data layers that appear on this map may or may not be accurate, current, or otherwise reliable.

# Property Record Card

Eddy Assessor

**BUREAU OF LAND  
MANAGEMENT**

**Account: R074781**

Tax Area: CO\_NR - CARLSBAD-  
OUT (Nonresidential)

Acres: 0.000

**Parcel: 4-185-118-263-264**

Situs Address:

## Value Summary

Value By:	Market	Override
Land (1)	\$2,880	N/A
<b>Total</b>	<b>\$2,880</b>	<b>\$2,880</b>

## Legal Description

Quarter: NE S: 23 T: 20S R: 31E Quarter: NW S: 23 T: 20S R: 31E  
Quarter: SW S: 23 T: 20S R: 31E Quarter: SE S: 23 T: 20S R: 31E ALL  
MAP# 174-23 LOC W OF BUFFALO GRASS RD EXEMPT

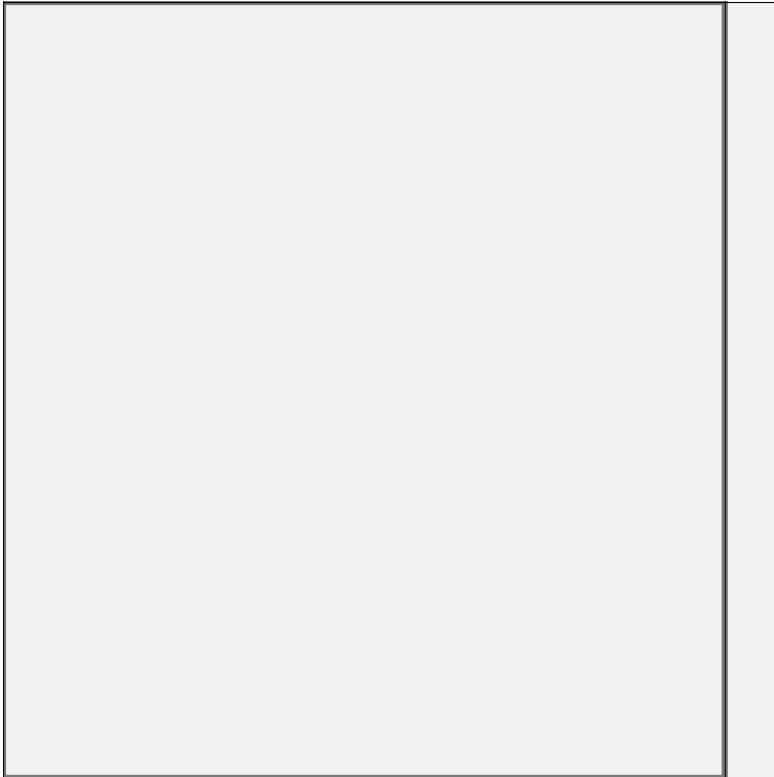

## Land Occurrence 1

Property Code 9200 - EXEMPT NON-RESIDENTIAL LAND Land Code 141\_4\_5 - Grazing E Federal - 4.5

## Abstract Summary

Code	Classification	Actual Value	Value	Taxable Value	Actual Value Override	Taxable Override
9200	EXEMPT NON-RESIDENTIAL LAND		\$2,880	\$960	NA	NA
<b>Total</b>			<b>\$2,880</b>	<b>\$960</b>	<b>NA</b>	<b>NA</b>



OBJECTID\_12\_13\_14: 5503  
UPC: 4-184-119-263-264  
UPC\_join: 4184119263264  
ACCOUNTNUMBER: R074786  
LEGALSUMMARY: Quarter: NE S: 27 T: 20S  
R: 31E Quarter: NW S: 27 T: 20S R: 31E  
Quarter: SW S: 27 T: 20S R: 31E Quarter: SE S:  
27 T: 20S R: 31E NE, NW, SE LESS 6.14 AC,  
SW MAP# 174-27 LOC N OF HWY 62-180  
EXEMPT  
OWNERNAME: BUREAU OF LAND  
MANAGEMENT  
LANDACTUAL: 2853  
OBJECTID\_1: 45221  
TAXYEAR\_1: 2020  
ACCOUNTNUMBER\_1: R074786  
SEQUENCE\_R: 0  
OWNER\_OCCURENCE: 0  
INTERNALID: C20160020093.1451631600000  
DOCUMENT\_TTYPE: Owner  
ACTIVE\_1: A  
CONFIDENTIAL: 0  
OWNERID\_1: C20160020093  
OBJECTID\_12: 35989  
TAXYEAR\_12: 2020  
ACCOUNTNUMBER\_12: R074786  
SEQUENCE\_R\_1: 0  
INTERNALID\_1:  
R074786.LAND2767745.1511254993524  
MODEL\_TYPE: Land  
ACCOUNTNUMBER\_12\_13: R074786  
ACTUALAREA: 633.86  
LANDCODE: 141\_4\_5  
TAXAREA: CO\_NR  
VERSIONEND\_1: 9223372036854775807  
VERSIONSTART\_1: 1511254993524

This map is a user generated static output from an Internet mapping site and is for reference only. Data layers that appear on this map may or may not be accurate, current, or otherwise reliable.



# Property Record Card

Eddy Assessor

**BUREAU OF LAND  
MANAGEMENT**

**Account: R074786**  
Tax Area: CO\_NR - CARLSBAD-  
OUT (Nonresidential)  
Acres: 0.000

**Parcel: 4-184-119-263-264**  
Situs Address:

## Value Summary

Value By:	Market	Override
Land (1)	\$2,853	N/A
<b>Total</b>	<b>\$2,853</b>	<b>\$2,853</b>

## Legal Description

Quarter: NE S: 27 T: 20S R: 31E Quarter: NW S: 27 T: 20S R: 31E  
Quarter: SW S: 27 T: 20S R: 31E Quarter: SE S: 27 T: 20S R: 31E NE,  
NW, SE LESS 6.14 AC, SW MAP# 174-27 LOC N OF HWY 62-180  
EXEMPT

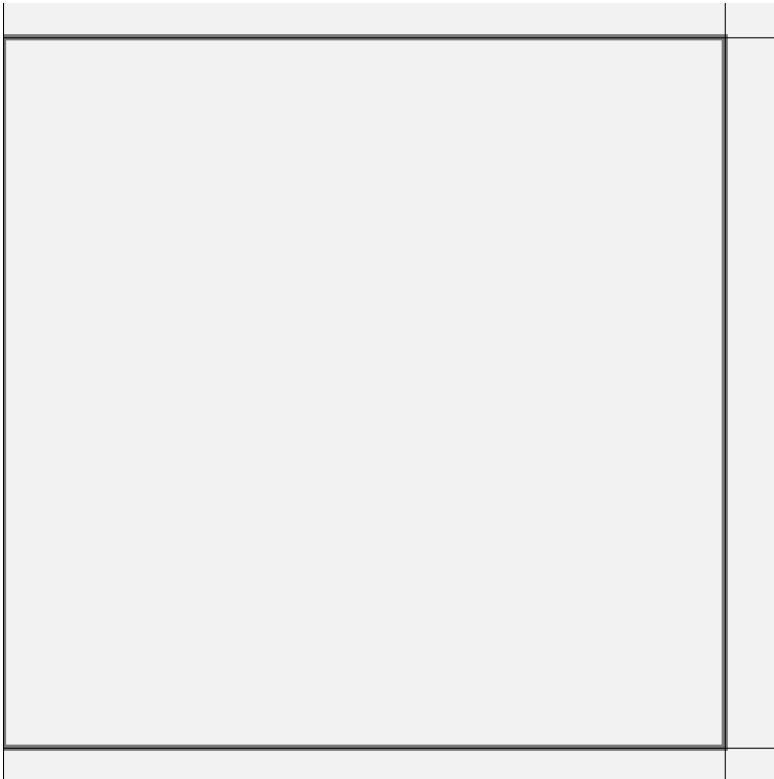

## Land Occurrence 1

Property Code	9200 - EXEMPT NON-RESIDENTIAL LAND	Land Code	141_4_5 - Grazing E Federal - 4.5
---------------	---------------------------------------	-----------	-----------------------------------

## Abstract Summary

Code	Classification	Actual Value	Value	Taxable Value	Actual Value Override	Taxable Override
9200	EXEMPT NON-RESIDENTIAL LAND		\$2,853	\$951	NA	NA
<b>Total</b>			<b>\$2,853</b>	<b>\$951</b>	<b>NA</b>	<b>NA</b>

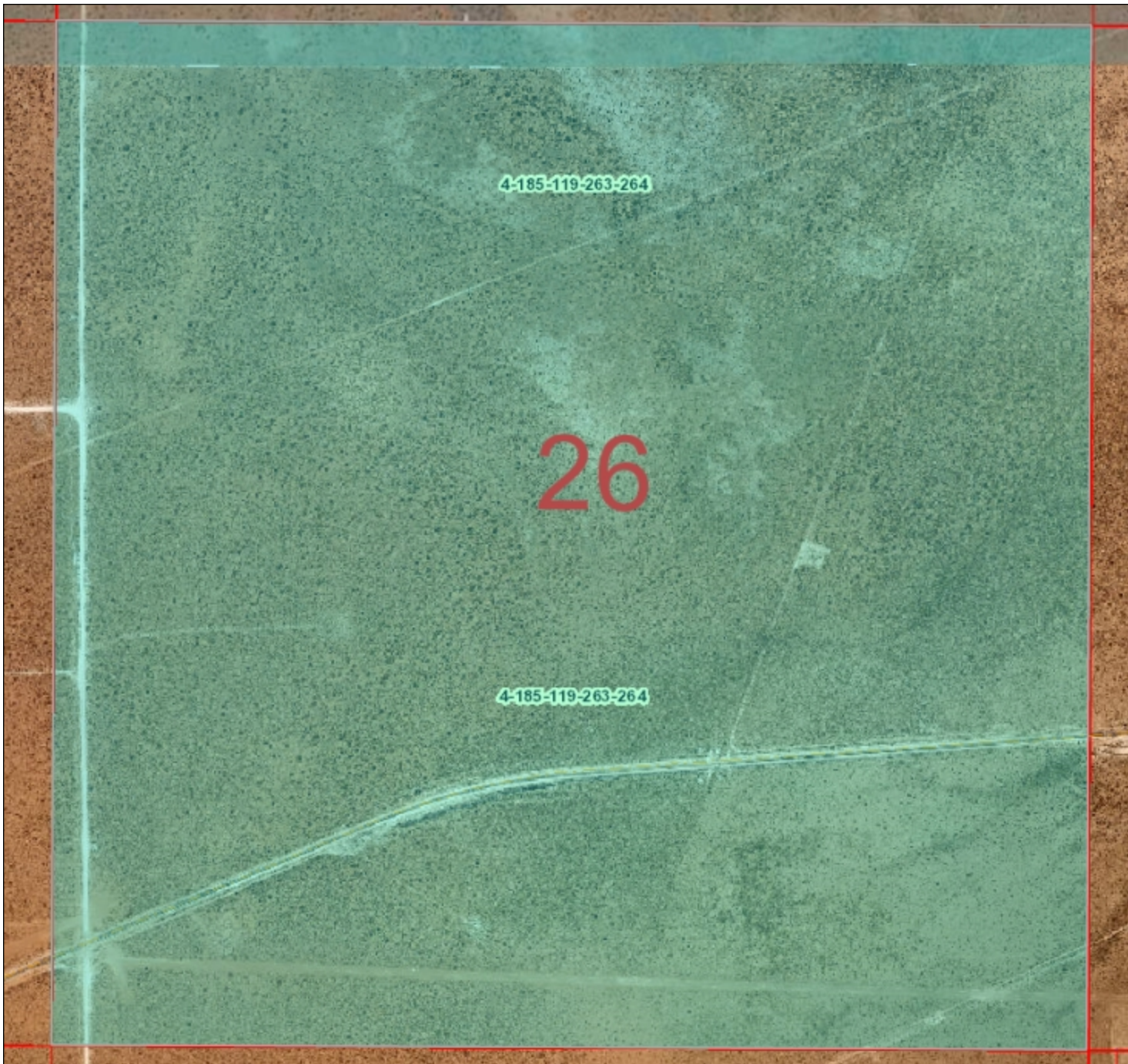

OBJECTID\_12\_13\_14: 5520  
UPC: 4-185-119-263-264  
UPC\_join: 4185119263264  
ACCOUNTNUMBER: R074784  
LEGALSUMMARY: Quarter: NE S: 26 T: 20S  
R: 31E Quarter: NW S: 26 T: 20S R: 31E  
Quarter: SW S: 26 T: 20S R: 31E Quarter: SE S:  
26 T: 20S R: 31E NE, NW, SE LESS 12.17 AC,  
SW LESS 12.88 AC MAP# 174-26 LOC N OF  
HWY 62-180 EXEMPT  
OWNERNAME: BUREAU OF LAND  
MANAGEMENT  
LANDACTUAL: 2766  
OBJECTID\_1: 45219  
TAXYEAR\_1: 2020  
ACCOUNTNUMBER\_1: R074784  
SEQUENCE\_R: 0  
OWNER\_OCCURENCE: 0  
INTERNALID: C20160020093.145163160000  
DOCUMENTTYPE: Owner  
ACTIVE\_1: A  
CONFIDENTIAL: 0  
OWNERID\_1: C20160020093  
OBJECTID\_12: 35987  
TAXYEAR\_12: 2020  
ACCOUNTNUMBER\_12: R074784  
SEQUENCE\_R\_1: 0  
INTERNALID\_1:  
R074784.LAND2767744.1511254992221  
MODEL\_TYPE: Land  
ACCOUNTNUMBER\_12\_13: R074784  
ACTUALAREA: 614.95  
LANDCODE: 141\_4\_5  
TAXAREA: CO\_NR  
VERSIONEND\_1: 9223372036854775807  
VERSIONSTART\_1: 1511254992221

This map is a user generated static output from an Internet mapping site and is for reference only. Data layers that appear on this map may or may not be accurate, current, or otherwise reliable.

# Property Record Card

Eddy Assessor

**BUREAU OF LAND  
MANAGEMENT**

**Account: R074784**

**Parcel: 4-185-119-263-264**

Tax Area: CO\_NR - CARLSBAD-  
OUT (Nonresidential)

Situs Address:

Acres: 0.000

## Value Summary

Value By:	Market	Override
Land (1)	\$2,766	N/A
<b>Total</b>	<b>\$2,766</b>	<b>\$2,766</b>

## Legal Description

Quarter: NE S: 26 T: 20S R: 31E Quarter: NW S: 26 T: 20S R: 31E  
Quarter: SW S: 26 T: 20S R: 31E Quarter: SE S: 26 T: 20S R: 31E NE,  
NW, SE LESS 12.17 AC, SW LESS 12.88 AC MAP# 174-26 LOC N OF  
HWY 62-180 EXEMPT

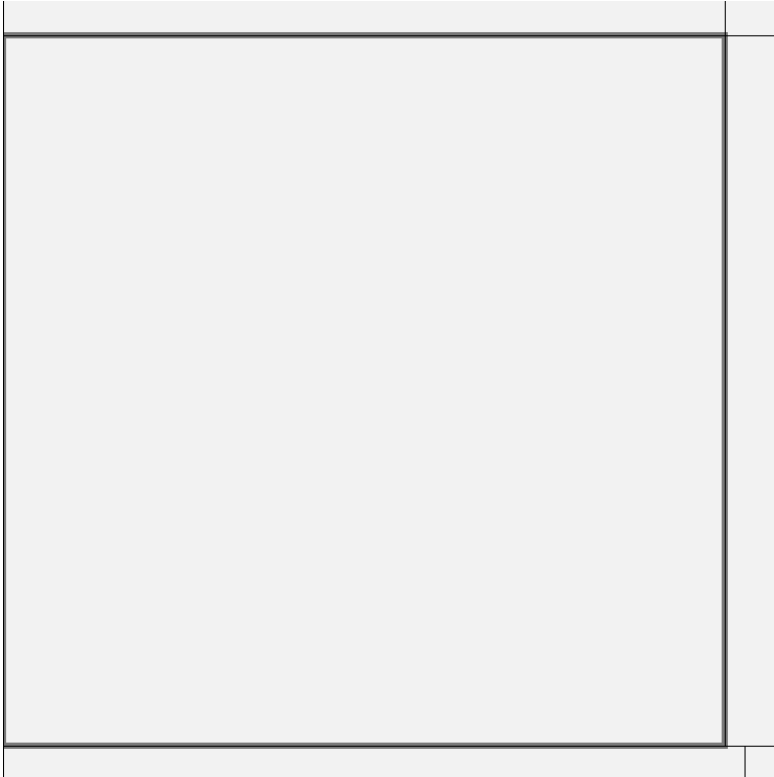

## Land Occurrence 1

Property Code	9200 - EXEMPT NON-RESIDENTIAL LAND	Land Code	141_4_5 - Grazing E Federal - 4.5
---------------	---------------------------------------	-----------	-----------------------------------

## Abstract Summary

Code	Classification	Actual Value	Value	Taxable Value	Actual Value Override	Taxable Override
9200	EXEMPT NON-RESIDENTIAL LAND		\$2,766	\$922	NA	NA
<b>Total</b>			<b>\$2,766</b>	<b>\$922</b>	<b>NA</b>	<b>NA</b>



OBJECTID\_12\_13\_14: 5486  
UPC: 4-183-118-264-264  
UPC\_join: 4183118264264  
ACCOUNTNUMBER: R074778  
LEGALSUMMARY: Quarter: NE S: 21 T: 20S  
R: 31E Quarter: NW S: 21 T: 20S R: 31E  
Quarter: SW S: 21 T: 20S R: 31E Quarter: SE S:  
21 T: 20S R: 31E ALL MAP# 174-21 LOC N OF  
HWY 62-180 EXEMPT  
OWNERNAME: BUREAU OF LAND  
MANAGEMENT  
LANDACTUAL: 2880  
OBJECTID\_1: 45213  
TAXYEAR\_1: 2020  
ACCOUNTNUMBER\_1: R074778  
SEQUENCE\_R: 0  
OWNER\_OCCURENCE: 0  
INTERNALID: C20160020093.1451631600000  
DOCUMENT\_TTYPE: Owner  
ACTIVE\_1: A  
CONFIDENTIAL: 0  
OWNERID\_1: C20160020093  
OBJECTID\_12: 35981  
TAXYEAR\_12: 2020  
ACCOUNTNUMBER\_12: R074778  
SEQUENCE\_R\_1: 0  
INTERNALID\_1:  
R074778.LAND2767739.1511254989060  
MODEL\_TYPE: Land  
ACCOUNTNUMBER\_12\_13: R074778  
ACTUALAREA: 640  
LANDCODE: 141\_4\_5  
TAXAREA: CO\_NR  
VERSIONEND\_1: 9223372036854775807  
VERSIONSTART\_1: 1511254989060

This map is a user generated static output from an Internet mapping site and is for reference only. Data layers that appear on this map may or may not be accurate, current, or otherwise reliable.

# Property Record Card

Eddy Assessor

**BUREAU OF LAND  
MANAGEMENT**

**Account: R074778**

Tax Area: CO\_NR - CARLSBAD-  
OUT (Nonresidential)

Acres: 0.000

**Parcel: 4-183-118-264-264**

Situs Address:

## Value Summary

Value By:	Market	Override
Land (1)	\$2,880	N/A
<b>Total</b>	<b>\$2,880</b>	<b>\$2,880</b>

## Legal Description

Quarter: NE S: 21 T: 20S R: 31E Quarter: NW S: 21 T: 20S R: 31E  
Quarter: SW S: 21 T: 20S R: 31E Quarter: SE S: 21 T: 20S R: 31E ALL  
MAP# 174-21 LOC N OF HWY 62-180 EXEMPT

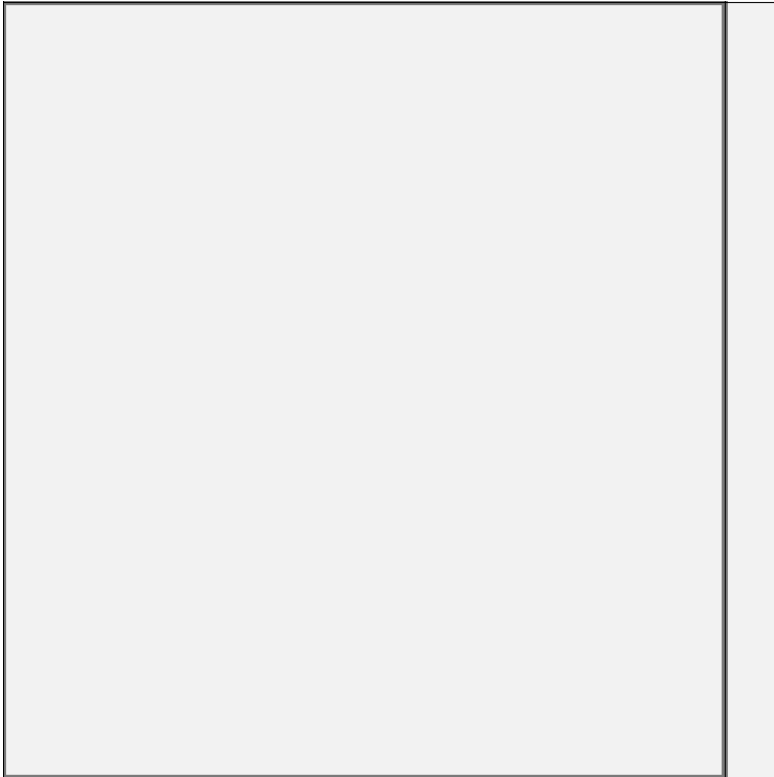

## Land Occurrence 1

Property Code 9200 - EXEMPT NON-RESIDENTIAL LAND Land Code 141\_4\_5 - Grazing E Federal - 4.5

## Abstract Summary

Code	Classification	Actual Value	Value	Taxable Value	Actual Value Override	Taxable Override
9200	EXEMPT NON-RESIDENTIAL LAND		\$2,880	\$960	NA	NA
<b>Total</b>			<b>\$2,880</b>	<b>\$960</b>	<b>NA</b>	<b>NA</b>



OBJECTID\_12\_13\_14: 5518  
UPC: 4-185-117-263-265  
UPC\_join: 4185117263265  
ACCOUNTNUMBER: R074767  
LEGALSUMMARY: Quarter: NE S: 14 T: 20S  
R: 31E Quarter: NW S: 14 T: 20S R: 31E  
Quarter: SW S: 14 T: 20S R: 31E Quarter: SE S:  
14 T: 20S R: 31E ALL MAP# 174-14 LOC N OF  
HWY 62-180 EXEMPT  
OWNERNAME: BUREAU OF LAND  
MANAGEMENT  
LANDACTUAL: 2880  
OBJECTID\_1: 45202  
TAXYEAR\_1: 2020  
ACCOUNTNUMBER\_1: R074767  
SEQUENCE\_R: 0  
OWNER\_OCCURENCE: 0  
INTERNALID: C20160020093.1451631600000  
DOCUMENT\_TTYPE: Owner  
ACTIVE\_1: A  
CONFIDENTIAL: 0  
OWNERID\_1: C20160020093  
OBJECTID\_12: 35970  
TAXYEAR\_12: 2020  
ACCOUNTNUMBER\_12: R074767  
SEQUENCE\_R\_1: 0  
INTERNALID\_1:  
R074767.LAND2767733.1511254982422  
MODEL\_TYPE: Land  
ACCOUNTNUMBER\_12\_13: R074767  
ACTUALAREA: 640  
LANDCODE: 141\_4\_5  
TAXAREA: CO\_NR  
VERSIONEND\_1: 9223372036854775807  
VERSIONSTART\_1: 1511254982422

This map is a user generated static output from an Internet mapping site and is for reference only. Data layers that appear on this map may or may not be accurate, current, or otherwise reliable.

# Property Record Card

Eddy Assessor

**BUREAU OF LAND  
MANAGEMENT**

**Account: R074767**

Tax Area: CO\_NR - CARLSBAD-  
OUT (Nonresidential)

Acres: 0.000

**Parcel: 4-185-117-263-265**

Situs Address:

## Value Summary

Value By:	Market	Override
Land (1)	\$2,880	N/A
<b>Total</b>	<b>\$2,880</b>	<b>\$2,880</b>

## Legal Description

Quarter: NE S: 14 T: 20S R: 31E Quarter: NW S: 14 T: 20S R: 31E  
Quarter: SW S: 14 T: 20S R: 31E Quarter: SE S: 14 T: 20S R: 31E ALL  
MAP# 174-14 LOC N OF HWY 62-180 EXEMPT

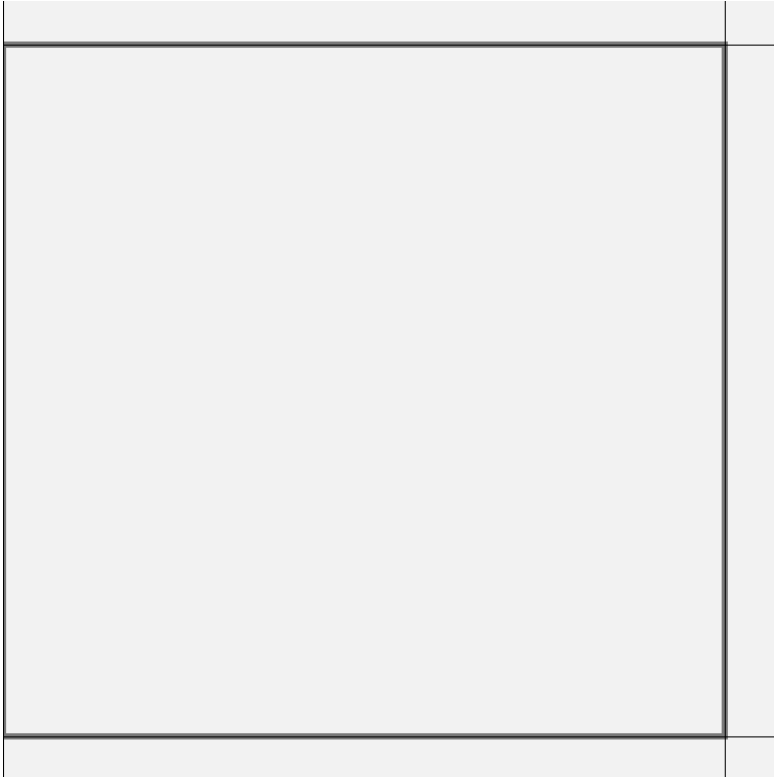

## Land Occurrence 1

Property Code 9200 - EXEMPT NON-RESIDENTIAL LAND Land Code 141\_4\_5 - Grazing E Federal - 4.5

## Abstract Summary

Code	Classification	Actual Value	Value	Taxable Value	Actual Value Override	Taxable Override
9200	EXEMPT NON-RESIDENTIAL LAND		\$2,880	\$960	NA	NA
<b>Total</b>			<b>\$2,880</b>	<b>\$960</b>	<b>NA</b>	<b>NA</b>



OBJECTID\_12\_13\_14: 5487  
UPC: 4-183-119-265-264  
UPC\_join: 4183119265264  
ACCOUNTNUMBER: R074787  
LEGALSUMMARY: Quarter: NE S: 28 T: 20S  
R: 31E Quarter: NW S: 28 T: 20S R: 31E  
Quarter: SW S: 28 T: 20S R: 31E Quarter: SE S:  
28 T: 20S R: 31E ALL MAP# 174-28 LOC N OF  
HWY 62-180 EXEMPT  
OWNERNAME: BUREAU OF LAND  
MANAGEMENT  
LANDACTUAL: 2880  
OBJECTID\_1: 45222  
TAXYEAR\_1: 2020  
ACCOUNTNUMBER\_1: R074787  
SEQUENCE\_R: 0  
OWNER\_OCCURENCE: 0  
INTERNALID: C20160020093.1451631600000  
DOCUMENT\_TTYPE: Owner  
ACTIVE\_1: A  
CONFIDENTIAL: 0  
OWNERID\_1: C20160020093  
OBJECTID\_12: 35990  
TAXYEAR\_12: 2020  
ACCOUNTNUMBER\_12: R074787  
SEQUENCE\_R\_1: 0  
INTERNALID\_1:  
R074787.LAND2767746.1511254993993  
MODEL\_TYPE: Land  
ACCOUNTNUMBER\_12\_13: R074787  
ACTUALAREA: 640  
LANDCODE: 141\_4\_5  
TAXAREA: CO\_NR  
VERSIONEND\_1: 9223372036854775807  
VERSIONSTART\_1: 1511254993993

This map is a user generated static output from an Internet mapping site and is for reference only. Data layers that appear on this map may or may not be accurate, current, or otherwise reliable.



# Property Record Card

Eddy Assessor

**BUREAU OF LAND  
MANAGEMENT**

**Account: R074787**  
Tax Area: CO\_NR - CARLSBAD-  
OUT (Nonresidential)  
Acres: 0.000

**Parcel: 4-183-119-265-264**  
Situs Address:

## Value Summary

Value By:	Market	Override
Land (1)	\$2,880	N/A
<b>Total</b>	<b>\$2,880</b>	<b>\$2,880</b>

## Legal Description

Quarter: NE S: 28 T: 20S R: 31E Quarter: NW S: 28 T: 20S R: 31E  
Quarter: SW S: 28 T: 20S R: 31E Quarter: SE S: 28 T: 20S R: 31E ALL  
MAP# 174-28 LOC N OF HWY 62-180 EXEMPT

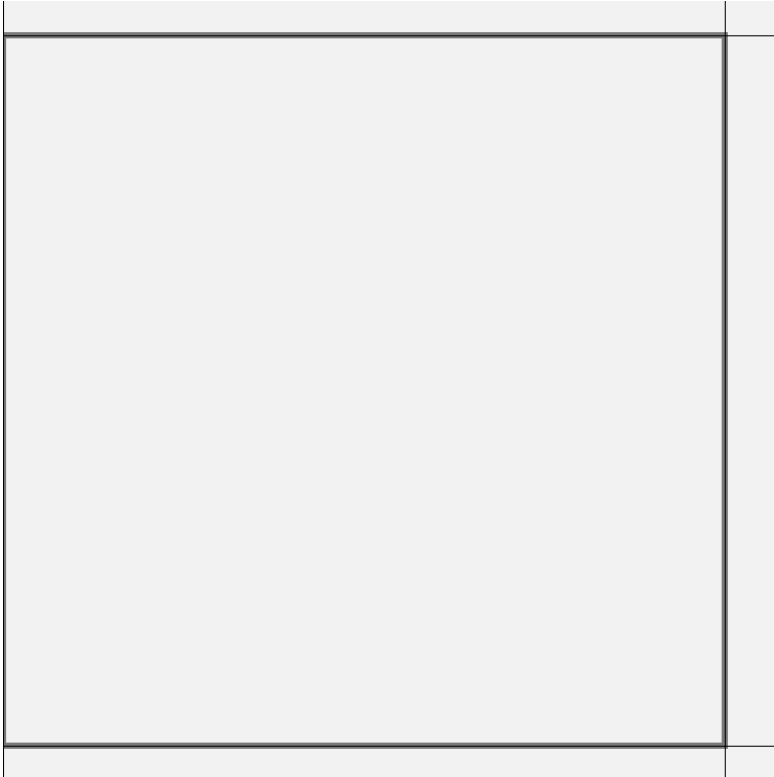

## Land Occurrence 1

Property Code	9200 - EXEMPT NON-RESIDENTIAL LAND	Land Code	141_4_5 - Grazing E Federal - 4.5
---------------	---------------------------------------	-----------	-----------------------------------

## Abstract Summary

Code	Classification	Actual Value	Value	Taxable Value	Actual Value Override	Taxable Override
9200	EXEMPT NON-RESIDENTIAL LAND		\$2,880	\$960	NA	NA
<b>Total</b>			<b>\$2,880</b>	<b>\$960</b>	<b>NA</b>	<b>NA</b>

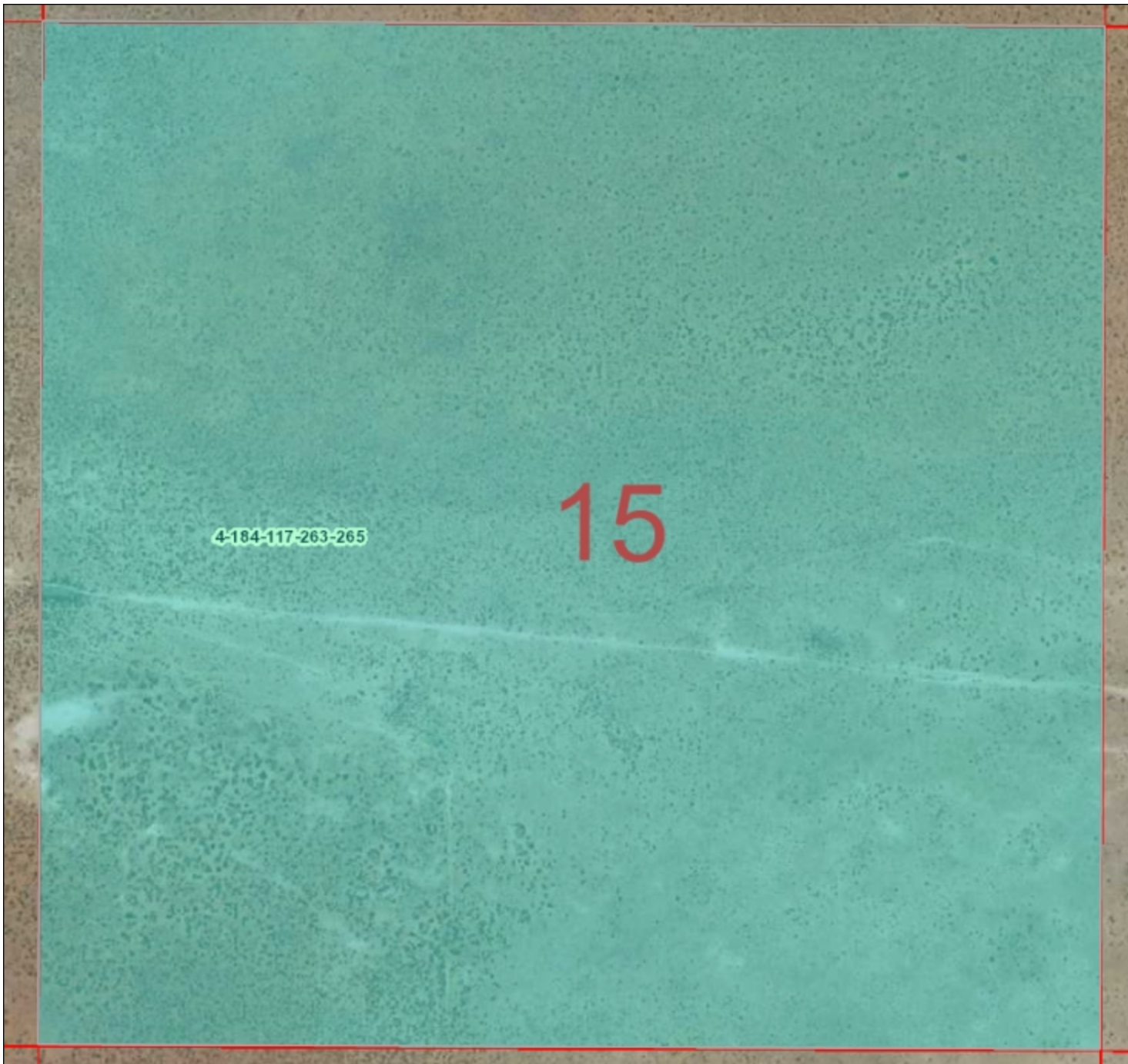

OBJECTID\_12\_13\_14: 5501  
UPC: 4-184-117-263-265  
UPC\_join: 4184117263265  
ACCOUNTNUMBER: R074768  
LEGALSUMMARY: Quarter: NE S: 15 T: 20S  
R: 31E Quarter: NW S: 15 T: 20S R: 31E  
Quarter: SW S: 15 T: 20S R: 31E Quarter: SE S:  
15 T: 20S R: 31E ALL MAP# 174-15 LOC N OF  
HWY 62-180 EXEMPT  
OWNERNAME: BUREAU OF LAND  
MANAGEMENT  
LANDACTUAL: 2880  
OBJECTID\_1: 45203  
TAXYEAR\_1: 2020  
ACCOUNTNUMBER\_1: R074768  
SEQUENCE\_R: 0  
OWNER\_OCCURENCE: 0  
INTERNALID: C20160020093.1451631600000  
DOCUMENT\_TTYPE: Owner  
ACTIVE\_1: A  
CONFIDENTIAL: 0  
OWNERID\_1: C20160020093  
OBJECTID\_12: 35971  
TAXYEAR\_12: 2020  
ACCOUNTNUMBER\_12: R074768  
SEQUENCE\_R\_1: 0  
INTERNALID\_1:  
R074768.LAND2767734.1511254982892  
MODEL\_TYPE: Land  
ACCOUNTNUMBER\_12\_13: R074768  
ACTUALAREA: 640  
LANDCODE: 141\_4\_5  
TAXAREA: CO\_NR  
VERSIONEND\_1: 9223372036854775807  
VERSIONSTART\_1: 1511254982892

This map is a user generated static output from an Internet mapping site and is for reference only. Data layers that appear on this map may or may not be accurate, current, or otherwise reliable.

# Property Record Card

Eddy Assessor

**BUREAU OF LAND  
MANAGEMENT**

**Account: R074768**

Tax Area: CO\_NR - CARLSBAD-  
OUT (Nonresidential)

Acres: 0.000

**Parcel: 4-184-117-263-265**

Situs Address:

## Value Summary

Value By:	Market	Override
Land (1)	\$2,880	N/A
<b>Total</b>	<b>\$2,880</b>	<b>\$2,880</b>

## Legal Description

Quarter: NE S: 15 T: 20S R: 31E Quarter: NW S: 15 T: 20S R: 31E  
Quarter: SW S: 15 T: 20S R: 31E Quarter: SE S: 15 T: 20S R: 31E ALL  
MAP# 174-15 LOC N OF HWY 62-180 EXEMPT

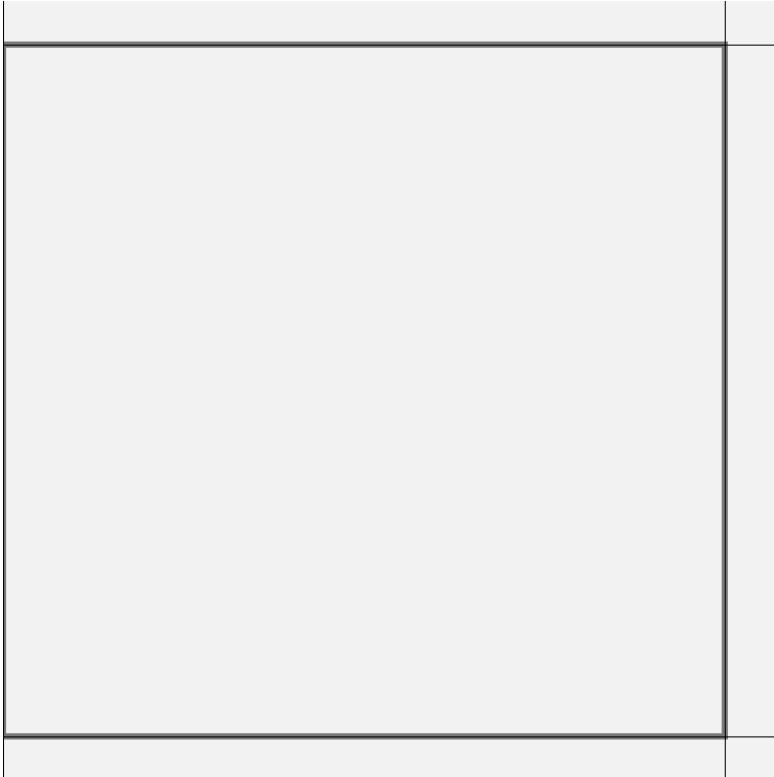

## Land Occurrence 1

Property Code 9200 - EXEMPT NON-RESIDENTIAL LAND Land Code 141\_4\_5 - Grazing E Federal - 4.5

## Abstract Summary

Code	Classification	Actual Value	Value	Taxable Value	Actual Value Override	Taxable Override
9200	EXEMPT NON-RESIDENTIAL LAND		\$2,880	\$960	NA	NA
<b>Total</b>			<b>\$2,880</b>	<b>\$960</b>	<b>NA</b>	<b>NA</b>

**Items 4 & 5.**

**Letters to Owners of Record and Applicable  
Counties, Municipalities, and Tribes**



22777 Springwoods Village Parkway  
Spring, Texas 77389  
(832) 625-0104

August 31, 2020

Certified Mail No. 7018 1130 0002 2476 2604

Bureau of Land Management  
620 E. Greene St.  
Carlsbad, New Mexico, 88220-6292

**RE: NSR Permit Application**  
Bulldog Compressor Station  
XTO Energy Inc.

Dear Federal Official,

In accordance with the application requirements of 20.2.72 NMAC, XTO Energy Inc. is providing notification of the planned modification of the Bulldog Compressor Station on your property in Eddy County, NM. A public notice will be published in the Artesia Daily Press newspaper, at the proposed site location, two other locations in Carlsbad, NM and one location in Hobbs, NM. A copy of the notice is attached. Please contact me at (832) 624-2768 should you have any questions.

Sincerely,

A handwritten signature in black ink that reads "Ben Schneider".

Benjamin Schneider  
Environmental Engineer

Attachment: Public Notice



22777 Springwoods Village Parkway  
Spring, Texas 77389  
(832) 625-0104

August 31, 2020

Certified Mail No. 7018 1130 0002 2476 2611

Eddy County  
101 W. Greene St.  
Suite 110  
Carlsbad, New Mexico, 88220

**RE: NSR Permit Application**  
Bulldog Compressor Station  
XTO Energy Inc.

Dear County Manager,

In accordance with the application requirements of 20.2.72 NMAC, XTO Energy Inc. is providing notification of the planned modification of the Bulldog Compressor Station in Eddy County, NM. A public notice will be published in the Artesia Daily Press newspaper, at the proposed site location, two other locations in Carlsbad, NM and one location in Hobbs, NM. A copy of the notice is attached. Please contact me at (832) 624-2768 should you have any questions.

Sincerely,

A handwritten signature in black ink that reads 'Ben Schneider'.

Benjamin Schneider  
Environmental Engineer

Attachment: Public Notice



22777 Springwoods Village Parkway  
Spring, Texas 77389  
(832) 625-0104

August 31, 2020

Certified Mail No. 7018 1130 0002 2476 2628

Lea County Manager  
100 N. Main Avenue  
Suite 4  
Lovington, New Mexico, 88260

**RE: NSR Permit Application**  
Bulldog Compressor Station  
XTO Energy Inc.

Dear County Manager,

In accordance with the application requirements of 20.2.72 NMAC, XTO Energy Inc. is providing notification of the planned modification of the Bulldog Compressor Station in Eddy County, NM. The proposed site is within 10 miles of Lea County. A public notice will be published in the Artesia Daily Press newspaper, at the proposed site location, two other locations in Carlsbad, NM and one location in Hobbs, NM. A copy of the notice is attached. Please contact me at (832) 624-2768 should you have any questions.

Sincerely,

A handwritten signature in cursive script that reads "Ben Schneider".

Benjamin Schneider  
Environmental Engineer

Attachment: Public Notice



22777 Springwoods Village Parkway  
Spring, Texas 77389  
(832) 625-0104

August 31, 2020

Certified Mail No. 7018 1130 0002 2476 2635

State of New Mexico Land Office  
310 Old Santa Fe Trail  
Santa Fe, New Mexico, 87501

**RE: NSR Permit Application**  
Bulldog Compressor Station  
XTO Energy Inc.

Dear Commissioner,

In accordance with the application requirements of 20.2.72 NMAC, XTO Energy Inc. is providing notification of the planned modification of the Bulldog Compressor Station near your property in Eddy County, NM. A public notice will be published in the Artesia Daily Press newspaper, at the proposed site location, two other locations in Carlsbad, NM and one location in Hobbs, NM. A copy of the notice is attached. Please contact me at (832) 624-2768 should you have any questions.

Sincerely,

A handwritten signature in cursive script that reads 'Ben Schneider'.

Benjamin Schneider  
Environmental Engineer

Attachment: Public Notice



**Item 6.**

**Sample of Notice posted and  
Verification of Postings**

# NOTICE OF AIR QUALITY PERMIT APPLICATION

XTO Energy, Inc. announces its application to the New Mexico Environment Department for an air quality permit for the modification of the Bulldog Compressor Station. The expected date of application submittal to the Air Quality Bureau is August 28, 2020.

The exact location for the facility known as the Bulldog Compressor Station will be latitude 32 deg, 33 min, 24 sec and longitude -103 deg, 51 min, 19 sec. The approximate location of this facility is 22 miles northeast of Carlsbad in Eddy County.

The proposed modification consists removing two engines, updating engine emission rates, updating glycol recirculation rate, removing two heaters, and updating oil/water production rates.

The estimated maximum quantities of any regulated air contaminants will be as follows in pound per hour (pph) and tons per year (tpy). These reported emissions could change slightly during the course of the Department's review:

Pollutant:	Pounds per hour	Tons per year
Particulate Matter (PM)	27 pph	17 tpy
PM <sub>10</sub>	27 pph	17 tpy
PM <sub>2.5</sub>	27 pph	17 tpy
Sulfur Dioxide (SO <sub>2</sub> )	10 pph	20 tpy
Nitrogen Oxides (NO <sub>x</sub> )	587 pph	206 tpy
Carbon Monoxide (CO)	1130 pph	228 tpy
Volatile Organic Compounds (VOC)	1113 pph	260 tpy
Total sum of all Hazardous Air Pollutants (HAPs)	35 pph	29 tpy
Toxic Air Pollutant (TAP)	35 pph	29 tpy
Green House Gas Emissions as Total CO <sub>2e</sub>	n/a	240,024 tpy

The standard and maximum operating schedule of the facility will be 24 hours per day, 7 days a week and a maximum of 52 weeks per year. The owner and/or operator of the Facility is: XTO Energy, Inc.; 22777 Springwoods Village Pkwy-W4.6B.347; Spring, Texas 77389.

If you have any comments about the construction or operation of this facility, and you want your comments to be made as part of the permit review process, you must submit your comments in writing to this address: Permit Programs Manager; New Mexico Environment Department; Air Quality Bureau; 525 Camino de los Marquez, Suite 1; Santa Fe, New Mexico; 87505-1816; (505) 476-4300; 1 800 224-7009; [https://www.env.nm.gov/aqb/permit/aqb\\_draft\\_permits.html](https://www.env.nm.gov/aqb/permit/aqb_draft_permits.html). Other comments and questions may be submitted verbally.

Please refer to the company name and site name, or send a copy of this notice along with your comments, since the Department may have not yet received the permit application. Please include a legible return mailing address with your comments. Once the Department has performed a preliminary review of the application and its air quality impacts, the Department's notice will be published in the legal section of a newspaper circulated near the facility location.

General information about air quality and the permitting process can be found at the Air Quality Bureau's web site. The regulation dealing with public participation in the permit review process is 20.2.72.206 NMAC. This regulation can be found in the "Permits" section of this web site.

## Atención

Este es un aviso de la oficina de Calidad del Aire del Departamento del Medio Ambiente de Nuevo México, acerca de las emisiones producidas por un establecimiento en esta área. Si usted desea información en español, por favor comuníquese con esa oficina al teléfono 505-476-5557.

## Notice of Non-Discrimination

NMED does not discriminate on the basis of race, color, national origin, disability, age or sex in the administration of its programs or activities, as required by applicable laws and regulations. NMED is responsible for coordination of compliance efforts and receipt of inquiries concerning non-discrimination requirements implemented by 40 C.F.R. Part 7, including Title VI of the Civil Rights Act of 1964, as amended; Section 504 of the Rehabilitation Act of 1973; the Age Discrimination Act of 1975, Title IX of the Education Amendments of 1972, and Section 13 of the Federal Water Pollution Control Act Amendments of 1972. If you have any questions about this notice or any of NMED's non-discrimination programs, policies or procedures, or if you believe that you have been discriminated against with respect to a NMED program or activity, you may contact: Kristine Yurdin, Non-Discrimination Coordinator, NMED, 1190 St. Francis Dr., Suite N4050, P.O. Box 5469, Santa Fe, NM 87502, (505) 827-2855, [nd.coordinator@state.nm.us](mailto:nd.coordinator@state.nm.us). You may also visit our website at <https://www.env.nm.gov/non-employee-discrimination-complaint-page/> to learn how and where to file a complaint of discrimination.

## General Posting of Notices – Certification

Bulldog Compressor Station  
Longhorn Compressor Station  
Jayhawk Compressor Station

I, Gary G. Goodgame, the undersigned, certify that on [DATE], posted a true and correct copy of the attached Public Notice in the following publicly accessible and conspicuous places in the **Carlsbad of Eddy** County, State of New Mexico on the following dates:

*All locations listed above:*

1. Facility entrance {DATE} Carlsbad Post Office 8-27-20
2. {Location 2} {DATE} Carlsbad Public Library 8-27-20
3. {Location 3} {DATE} Hobbs Post Office 8-28-20
4. {Location 4} {DATE}

Signed this 27 day of August, 2020.

Gary G. Goodgame  
Signature

8-27-20  
Date

Gary G. Goodgame  
Printed Name

Environmental & Waste Coordinator  
Title {APPLICANT OR RELATIONSHIP TO APPLICANT}

## General Posting of Notices – Certification

Bulldog Compressor Station  
Longhorn Compressor Station  
Jayhawk Compressor Station

I, Gary G. Goodgame, the undersigned, certify that on {DATE}, posted a true and correct copy of the attached Public Notice in the following publicly accessible and conspicuous places in the **Carlsbad** of **Eddy** County, State of New Mexico on the following dates:

1. Facility entrance {DATE} Bulldog CS off of 62/180 8-27-20
2. {Location 2} {DATE} Jayhawk CS off of 243 8-27-20
3. {Location 3} {DATE} Longhorn CS off of 128 8-27-20
4. {Location 4} {DATE}

Signed this 27 day of August, 2020.

Gary G. Goodgame  
Signature

8-27-20  
Date

Gary G. Goodgame  
Printed Name

Environmental + Waste Coordinator  
Title {APPLICANT OR RELATIONSHIP TO APPLICANT}

## NOTICE OF AIR QUALITY PERMIT APPLICATION

XTO Energy, Inc. announces its application to the New Mexico Environment Department for an air quality permit for the modification of the Building Compressor Station. The expected date of application is August 28, 2024.

The exact location for the facility is at the Building Compressor Station with the latitude 32 deg. 33 min. 24 sec and longitude -107 deg. 31 min. 14 sec. The approximate location of this facility is 22 miles northwest of Carlsbad in Eddy County.

The proposed modification consists removing two engines, updating engine emission rates, updating glycol recirculation rate, removing two heaters, and updating oil-water production rates.

The estimated maximum quantities of any regulated air contaminants will be as follows in pounds per hour (pph) and tons per year (tpy). These reported amounts could change slightly during the course of the Department's review.

Pollutant	Pounds per hour	Tons per year
Particulate Matter (PM)		
PM <sub>10</sub>	27 pph	17 tpy
PM <sub>2.5</sub>	27 pph	17 tpy
Sulfur Dioxide (SO <sub>2</sub> )	27 pph	17 tpy
Nitrogen Dioxide (NO <sub>2</sub> )	10 pph	24 tpy
Carbon Monoxide (CO)	187 pph	206 tpy
Volatile Organic Compounds (VOC)	1150 pph	228 tpy
Total sum of all regulated Air Pollutants (SRAPs)	1111 pph	240 tpy
Total Air Pollutants (TAP)	33 pph	24 tpy
Greenhouse Gas Emissions as Total CO <sub>2</sub> e	15 tpy	24 tpy
	0 tpy	240,024 tpy

The standard and maximum operating schedule of this facility is 24 hours per day, 7 days a week and a maximum of 32 weeks per year. The owner and/or operator of the facility is: XTO Energy, Inc., 20777 Springbrook Village Drive, Suite 207, Spring, Texas 77477.

If you have any comments about the construction or operation of this facility, and you want your comments to be made on part of the permit review process, you must submit your comments in writing to the address below: Program Manager, New Mexico Environment Department, Air Quality Bureau, 321 Camino de las Arbores, Suite 1, Santa Fe, New Mexico, 87503-1414, (505) 476-4100, 1-800-552-7688, [http://www.nm.gov/airquality/permits/air\\_quality\\_permits.html](http://www.nm.gov/airquality/permits/air_quality_permits.html). Other comments and questions may be submitted verbally.

Please refer to the company name and site name, or send a copy of this notice along with your comments, since the Department may not be notified for permit application. Please include a telephone number within your comments. Check the Department's website for a preliminary review of the application and its air quality impacts; the Department's website will be published in the legal notice of a complete application near the facility location.

Further information about air quality and the permitting process can be found at the Air Quality Bureau's web site. The registration fee for public participation in the permit review process is 20.2, 12,236 NMDC. This registration can be found in the "Permits" section of the web site.

**Spanish:**  
 Una copia de este aviso de aplicación de Calidad del Aire del Departamento del Medio Ambiente de Nuevo México, acerca de las modificaciones propuestas por un contaminante en una zona. Si usted desea información en español, por favor comuníquese con los efectos de aplicación de permisos.

**Notice of New Department**  
 The Department is the basis of race, color, national origin, disability, age or sex in the administration of its programs or activities. Any applicant for application laws and regulations. NMEDD is responsible for coordination of compliance efforts and receipt of information. Section 106 of the Rehabilitation Act of 1973, the Age Discrimination Act of 1975, Title IX of the Civil Rights Act of 1964, and Section 504 of the Federal Water Pollution Control Act Amendments of 1972. If you have any questions about the Department's non-discrimination program, policies or procedures, or if you believe that you have been discriminated against, please contact: Office of Civil Rights, New Mexico Environment Department, NMEDD, 1790 Louisiana, Santa Fe, NM 87503, (505) 476-4100, 1-800-552-7688, [www.nm.gov/airquality/permits/air\\_quality\\_permits.html](http://www.nm.gov/airquality/permits/air_quality_permits.html). You may also visit the Department's website at [www.nm.gov/airquality/permits/air\\_quality\\_permits.html](http://www.nm.gov/airquality/permits/air_quality_permits.html).

**Item 7.**

**A table of the noticed citizens, counties, municipalities and tribes and to whom the notices were sent in each group.**

**Noticed Citizens, Counties, Municipalities, and Tribes**

Eddy County: Eddy County Manager

Lea County: Lea County Manager

Bureau Of Land Management: Carlsbad Field Office (David Evans)

State of NM: Commissioner

**Item 8.**

**A copy of the public service announcement (PSA) sent to a local radio station and documentary proof of submittal.**

# Activity Report

Date/Time 08-31-2020  
Local ID 1 8326252631

02:53:47 p.m.

Transmit Header Text  
Local Name 1

## Completed Jobs : 1

No.	Job	Remote Station	Start Time	Duration	Pages	Line	Mode	Job Type	Results
001	450	VFD212M6N22	02:51:05 p.m. 08-31-2020	00:02:04	6/6	1	G3	HS	CP14400

## Abbreviations:

HS: Host send  
HR: Host receive  
WS: Waiting send

PL: Polled local  
PR: Polled remote  
MS: Mailbox save

MP: Mailbox print  
RP: Report  
FF: Fax Forward

CP: Completed  
FA: Fall  
TU: Terminated by user

TS: Terminated by system  
G3: Group 3  
EC: Error Correct



# Transmission Report

Date/Time  
Local ID 1

08-31-2020  
8326252631

02:53:47 p.m.

Transmit Header Text  
Local Name 1

**This document : Confirmed  
(reduced sample and details below)  
Document size : 8.5"x11"**

August 31, 2020

KATK 92.1 FM  
(575) 887-7000

**Re: Public Service Announcement**

As part of the air quality permitting process in New Mexico, applicants for certain air permits must attempt to provide notice to the public of the proposed permit action via public service announcement (PSA). The announcement is attached. Will you air the PSA?

Thank you.

Benjamin Schneider  
XTO Energy Inc.  
(832) 624-2768

Total Pages Scanned : 6

Total Pages Confirmed : 6

No.	Job	Remote Station	Start Time	Duration	Pages	Line	Mode	Job Type	Results
001	450	VFD212M6N22	02:51:05 p.m. 08-31-2020	00:02:04	6/6	1	G3	HS	CP14400

**Abbreviations:**

HS: Host send  
HR: Host receive  
WS: Waiting send

PL: Polled local  
PR: Polled remote  
MS: Mailbox save

MP: Mailbox print  
RP: Report  
FF: Fax Forward

CP: Completed  
FA: Fall  
TU: Terminated by user

TS: Terminated by system  
G3: Group 3  
EC: Error Correct

August 31, 2020

KATK 92.1 FM  
(575) 887-7000

Re: Public Service Announcement

As part of the air quality permitting process in New Mexico, applicants for certain air permits must attempt to provide notice to the public of the proposed permit action via public service announcement (PSA). The announcement is attached. Will you air the PSA?

Thank you.

Benjamin Schneider  
XTO Energy Inc.  
(832) 624-2768

## NOTICE OF AIR QUALITY PERMIT APPLICATION

XTO Energy, Inc. announces its application to the New Mexico Environment Department for an air quality permit for the modification of the Bulldog Compressor Station. The expected date of application submittal to the Air Quality Bureau is September 4, 2020. XTO Energy Inc. is planning to remove two engines, update engine emission rates, update glycol recirculation rate, remove two heaters, and update oil/water production rates.

The exact location for the proposed facility known as the Bulldog Compressor Station will be latitude 32 deg, 33 min, 24 sec and longitude - 103 deg, 51 min, 19 sec. The approximate location of this facility is 22 miles northeast of Carlsbad in Eddy County.

The notice was posted at the facility and three other public locations: The Carlsbad post office, the Carlsbad public library, and the Hobbs post office. If you have any comments about the construction or operation of the above facility, and you want your comments to be made as part of the permit review process, you must submit your comments in writing to the address below:

Permit Programs Manager  
New Mexico Environment Department  
Air Quality Bureau  
525 Camino de los Marquez, Suite 1  
Santa Fe, New Mexico 87505-1816  
(505) 476-4300

**Item 9.**

**A copy of the classified or legal ad including the page header (date and newspaper title)**

# Affidavit of Publication

No. 25527

State of New Mexico Publisher

County of Eddy:

**Danny Scott**

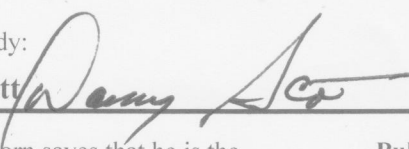

being duly sworn says that he is the Publisher

of the Artesia Daily Press, a daily newspaper of General circulation, published in English at Artesia, said county and state, and that the hereto attached

## Legal Ad

was published in a regular and entire issue of the said Artesia Daily Press, a daily newspaper duly qualified for that purpose within the meaning of Chapter 167 of the 1937 Session Laws of the state of New Mexico for 1 Consecutive weeks/day on the same

day as follows:

First Publication	August 20, 2020
Second Publication	
Third Publication	
Fourth Publication	
Fifth Publication	
Sixth Publication	
Seventh Publication	

Subscribed and sworn before me this

20th day of August 2020



OFFICIAL SEAL  
Latisha Romine  
NOTARY PUBLIC-STATE OF NEW MEXICO

My commission expires: 5/12/2023

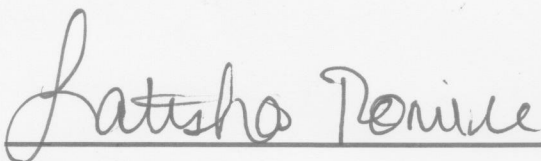

Latisha Romine

Notary Public, Eddy County, New Mexico

# Copy of Publication:

## Legal Notice

### NOTICE OF AIR QUALITY PERMIT APPLICATION

XTO Energy, Inc. announces its application to the New Mexico Environment Department for an air quality permit for the modification of the Bulldog Compressor Station. The expected date of application submittal to the Air Quality Bureau is August 28, 2020.

The exact location for the facility known as the Bulldog Compressor Station will be latitude 32 deg, 33 min, 24 sec and longitude

-103 deg, 51 min, 19 sec. The approximate location of this facility is 22 miles northeast of Carlsbad in Eddy County.

The proposed modification consists removing two engines, updating engine emission rates, updating glycol recirculation rate, removing two heaters, and updating oil/water production rates.

The estimated maximum quantities of any regulated air contaminants will be as follows in pound per hour (pph) and tons per year (tpy). These reported emissions could change slightly during the course of the Department's review:

Pollutant:	Pounds per hour	Tons per year
Particulate Matter (PM)		
PM 10	27 pph	17 tpy
PM 2.5	27 pph	17 tpy
Sulfur Dioxide (SO2)	10 pph	20 tpy
Nitrogen Oxides (NOx)	587 pph	206 tpy
Carbon Monoxide (CO)	1130 pph	228 tpy
Volatile Organic Compounds (VOC)	1113 pph	260 tpy
Total sum of all Hazardous Air Pollutants (HAPs)	35 pph	29 tpy
Toxic Air Pollutant (TAP)	35 pph	29 tpy
Green House Gas Emissions as Total CO2e	n/a	240,024 tpy

The standard and maximum operating schedule of the facility will be 24 hours per day, 7 days a week and a maximum of 52 weeks per year. The owner and/or operator of the Facility is: XTO Energy, Inc.; 22777 Springwoods Village Pkwy-W4.6B.347; Spring, Texas 77389.

If you have any comments about the construction or operation of this facility, and you want your comments to be made as part of the permit review process, you must submit your comments in writing to this address: Permit Programs Manager; New Mexico Environment Department; Air Quality Bureau; 525 Camino de los Marquez, Suite 1; Santa Fe, New Mexico; 87505-1816; (505) 476-4300; 1 800 224-7009; [https://www.env.nm.gov/aqb/permit/aqb\\_draft\\_permits.html](https://www.env.nm.gov/aqb/permit/aqb_draft_permits.html). Other comments and questions may be submitted verbally.

Please refer to the company name and site name, or send a copy of this notice along with your comments, since the Department may have not yet received the permit application. Please include a legible return mailing address with your comments. Once the Department has performed a preliminary review of the application and its air quality impacts, the Department's notice will be published in the legal section of a newspaper circulated near the facility location.

General information about air quality and the permitting process can be found at the Air Quality Bureau's web site. The



**Item 10.**

**A copy of the display ad including the page header (date and newspaper title) or its affidavit of publication stating the ad date, and a copy of the ad.**

# Affidavit of Publication

# Copy of Publication:

No. \_\_\_\_\_

State of New Mexico

Publisher

County of Eddy:

**Danny Scott**

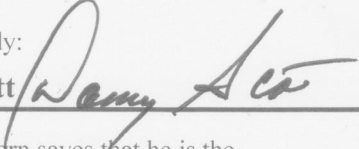

being duly sworn says that he is the

Publisher

of the Artesia Daily Press, a daily newspaper of General circulation, published in English at Artesia, said county and state, and that the hereto attached

### Display Ad

was published in a regular and entire issue of the said Artesia Daily Press, a daily newspaper duly qualified for that purpose within the meaning of Chapter 167 of the 1937 Session Laws of the state of New Mexico for 1 Consecutive weeks/day on the same

day as follows:

First Publication August 20, 2020

Second Publication \_\_\_\_\_

Third Publication \_\_\_\_\_

Fourth Publication \_\_\_\_\_

Fifth Publication \_\_\_\_\_

Sixth Publication \_\_\_\_\_

Seventh Publication \_\_\_\_\_

Subscribed and sworn before me this

20th day of August 2020



OFFICIAL SEAL  
Latisha Romine  
NOTARY PUBLIC-STATE OF NEW MEXICO

My commission expires: 5/12/2023

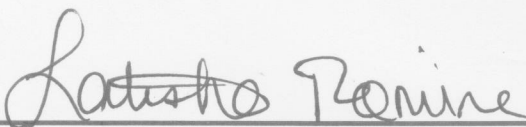

Latisha Romine

Notary Public, Eddy County, New Mexico

**NOTICE OF AIR QUALITY PERMIT APPLICATION**  
XTO Energy, Inc. announces its application to the New Mexico Environment Department for an air quality permit for the modification of the Bulldog Compressor Station. The expected date of application submittal to the Air Quality Bureau is August 28, 2020.

The exact location for the facility known as the Bulldog Compressor Station will be latitude 32 deg, 33 min, 24 sec and longitude

-103 deg, 51 min, 19 sec. The approximate location of this facility is 22 miles northeast of Carlsbad in Eddy County.

The proposed modification consists removing two engines, updating engine emission rates, updating glycol recirculation rate, removing two heaters, and updating oil/water production rates.

The estimated maximum quantities of any regulated air contaminants will be as follows in pound per hour (pph) and tons per year (tpy). These reported emissions could change slightly during the course of the Department's review:

Pollutant:	Pounds per hour	Tons per year
Particulate Matter (PM)		
PM 10	27 pph	17 tpy
PM 2.5	27 pph	17 tpy
Sulfur Dioxide (SO <sub>2</sub> )	10 pph	20 tpy
Nitrogen Oxides (NO <sub>x</sub> )	587 pph	206 tpy
Carbon Monoxide (CO)	1130 pph	228 tpy
Volatile Organic Compounds (VOC)	1113 pph	260 tpy
Total sum of all Hazardous Air Pollutants (HAPs)	35 pph	29 tpy
Toxic Air Pollutant (TAP)	35 pph	29 tpy
Green House Gas Emissions as Total CO <sub>2</sub> e	n/a	240,024 tpy

The standard and maximum operating schedule of the facility will be 24 hours per day, 7 days a week and a maximum of 52 weeks per year. The owner and/or operator of the Facility is: XTO Energy, Inc.; 22777 Springwoods Village Pkwy-W4.6B.347; Spring, Texas 77389.

If you have any comments about the construction or operation of this facility, and you want your comments to be made as part of the permit review process, you must submit your comments in writing to this address: Permit Programs Manager; New Mexico Environment Department; Air Quality Bureau; 525 Camino de los Marquez, Suite 1; Santa Fe, New Mexico; 87505-1816; (505) 476-4300; 1 800 224-7009; [https://www.env.nm.gov/aqb/permit/aqb\\_draft\\_permits.html](https://www.env.nm.gov/aqb/permit/aqb_draft_permits.html). Other comments and questions may be submitted verbally.

Please refer to the company name and site name, or send a copy of this notice along with your comments, since the Department may have not yet received the permit application. Please include a legible return mailing address with your comments. Once the Department has performed a preliminary review of the application and its air quality impacts, the Department's notice will be published in the legal section of a newspaper circulated near the facility location.

General information about air quality and the permitting process can be found at the Air Quality Bureau's web site. The regulation dealing with public participation in the per-





**Item 11.**

**A map with a graphic scale showing the facility boundary and the surrounding area in which owners of record were notified by mail.**



**Legend**

**Cartography**

- <all other values>
- Govt Lot Lines
- Dimension Tic
- Leader Lines
- Misc Carto
- Owner Hooks
- Sub Corners
- Roads
- Railroads
- Water
- Geographic
- Section
- Subdivision
- Parcel

**Bulldog Compressor Station 1/2 Mile Radius**

Web Print: 07/31/2020

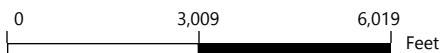

This map is a user generated static output from an Internet mapping site and is for reference only. Data layers that appear on this map may or may not be accurate, current, or otherwise reliable.



**Tab 10**

**Section 10 - Written Description of the Routine  
Operations of the Facility**

# Section 10

## Written Description of the Routine Operations of the Facility

---

**A written description of the routine operations of the facility.** Include a description of how each piece of equipment will be operated, how controls will be used, and the fate of both the products and waste generated. For modifications and/or revisions, explain how the changes will affect the existing process. In a separate paragraph describe the major process bottlenecks that limit production. The purpose of this description is to provide sufficient information about plant operations for the permit writer to determine appropriate emission sources.

---

Field gas flows into two inlet slug catchers. The site uses natural gas engines to compress the field gas to 1200-1300 psig, including nine (9) Caterpillar 3616TA engines (ENG1-ENG9) and two (2) Caterpillar 3516J engines (ENG11-ENG12). The Caterpillar engines are equipped with oxidation catalysts to reduce CO, VOC, and formaldehyde emissions.

The high-pressure gas is then dehydrated using triethylene glycol dehydration units (DEHY1-DEHY3), each handling up to 80 MMscfd each. The systems are equipped with flash tanks and condensers. Flash tank vapors are recycled in the dehydration system. The glycol still vent vapors are routed to condensers. Uncondensed vapors are controlled by the vapor combustor (VC1). Dehydrated gas is then transferred to a sales pipeline.

Low pressure liquids generated anywhere in the system are routed to a low pressure three phase separator (LPS). Vapors from the LPS are controlled by a VRU and routed to compression. When the LPS VRU is not operational, vapors from the LPS are routed to the flare system (FL1/FL2). From the LPS, oil at approximately 15 psig is dumped to four (4) oil storage tanks (OT1-OT4), which are controlled by the flare system (FL1/FL2). Water from the LPS flows to redundant skim tanks (SKT1/SKT2). The skim tanks are arranged as a redundant system in which one unit can be used if another is down for unforeseen circumstances. Water is then dumped to two (2) water tanks (WT1-WT2).

Any residual oil flows from the skim tanks into the oil storage tanks. The oil from the oil storage tanks are then pumped back into the high pressure three phase separator (HPS), to be transferred offsite via pipeline. Vapors from the water storage tanks and skim tanks are also controlled by the flare system (FL1/FL2). Oil can be trucked offsite or pumped offsite via pipeline, water is transferred offsite via pipeline to saltwater disposal (SWD).

High pressure liquids generated anywhere in the system are routed to high pressure three phase separator (HPS). Vapors from the high pressure separator are routed back to the inlet slug catchers. From the HPS, liquid hydrocarbons at approximately 400 psig are transferred offsite via pipeline. Water from the HPS is transferred offsite via pipeline to SWD.

The flare system (FL1/FL2) is also used to flare gas in the event of an emergency.

**Tab 11**  
**Section 11 -Source Determination**

# Section 11

## Source Determination

Source submitting under 20.2.70, 20.2.72, 20.2.73, and 20.2.74 NMAC

Sources applying for a construction permit, PSD permit, or operating permit shall evaluate surrounding and/or associated sources (including those sources directly connected to this source for business reasons) and complete this section. Responses to the following questions shall be consistent with the Air Quality Bureau's permitting guidance, Single Source Determination Guidance, which may be found on the Applications Page in the Permitting Section of the Air Quality Bureau website.

Typically, buildings, structures, installations, or facilities that have the same SIC code, that are under common ownership or control, and that are contiguous or adjacent constitute a single stationary source for 20.2.70, 20.2.72, 20.2.73, and 20.2.74 NMAC applicability purposes. Submission of your analysis of these factors in support of the responses below is optional, unless requested by NMED.

**A. Identify the emission sources evaluated in this section (list and describe):**

See Table 2A

**B. Apply the 3 criteria for determining a single source:**

**SIC Code:** Surrounding or associated sources belong to the same 2-digit industrial grouping (2-digit SIC code) as this facility, **OR** surrounding or associated sources that belong to different 2-digit SIC codes are support facilities for this source.

**Yes**       **No**

**Common Ownership or Control:** Surrounding or associated sources are under common ownership or control as this source.

**Yes**       **No**

**Contiguous or Adjacent:** Surrounding or associated sources are contiguous or adjacent with this source.

**Yes**       **No**

**C. Make a determination:**

The source, as described in this application, constitutes the entire source for 20.2.70, 20.2.72, 20.2.73, or 20.2.74 NMAC applicability purposes. If in "A" above you evaluated only the source that is the subject of this application, all "**YES**" boxes should be checked. If in "A" above you evaluated other sources as well, you must check **AT LEAST ONE** of the boxes "**NO**" to conclude that the source, as described in the application, is the entire source for 20.2.70, 20.2.72, 20.2.73, and 20.2.74 NMAC applicability purposes.

The source, as described in this application, **does not** constitute the entire source for 20.2.70, 20.2.72, 20.2.73, or 20.2.74 NMAC applicability purposes (A permit may be issued for a portion of a source). The entire source consists of the following facilities or emissions sources (list and describe):

**Tab 12**  
**Section 12 - PSD Applicability Determination for**  
**All Sources**



# Section 12

## Section 12.A

### PSD Applicability Determination for All Sources

(Submitting under 20.2.72, 20.2.74 NMAC)

---

**A PSD applicability determination for all sources.** For sources applying for a significant permit revision, apply the applicable requirements of 20.2.74.AG and 20.2.74.200 NMAC and to determine whether this facility is a major or minor PSD source, and whether this modification is a major or a minor PSD modification. It may be helpful to refer to the procedures for Determining the Net Emissions Change at a Source as specified by Table A-5 (Page A.45) of the EPA New Source Review Workshop Manual to determine if the revision is subject to PSD review.

A. This facility is:

- a minor PSD source before and after this modification (if so, delete C and D below).
- a major PSD source before this modification. This modification will make this a PSD minor source.
- an existing PSD Major Source that has never had a major modification requiring a BACT analysis.
- an existing PSD Major Source that has had a major modification requiring a BACT analysis
- a new PSD Major Source after this modification.

**Tab 13**

**Section 13 - Determination of State & Federal Air  
Quality Regulations**

# Section 13

## Determination of State & Federal Air Quality Regulations

---

**This section lists each state and federal air quality regulation that may apply to your facility and/or equipment that are stationary sources of regulated air pollutants.**

Not all state and federal air quality regulations are included in this list. Go to the Code of Federal Regulations (CFR) or to the Air Quality Bureau's regulation page to see the full set of air quality regulations.

### **Required Information for Specific Equipment:**

For regulations that apply to specific source types, in the 'Justification' column **provide any information needed to determine if the regulation does or does not apply. For example**, to determine if emissions standards at 40 CFR 60, Subpart IIII apply to your three identical stationary engines, we need to know the construction date as defined in that regulation; the manufacturer date; the date of reconstruction or modification, if any; if they are or are not fire pump engines; if they are or are not emergency engines as defined in that regulation; their site ratings; and the cylinder displacement.

### **Required Information for Regulations that Apply to the Entire Facility:**

See instructions in the 'Justification' column for the information that is needed to determine if an 'Entire Facility' type of regulation applies (e.g. 20.2.70 or 20.2.73 NMAC).

### **Regulatory Citations for Regulations That Do Not, but Could Apply:**

If there is a state or federal air quality regulation that does not apply, but you have a piece of equipment in a source category for which a regulation has been promulgated, you must **provide the low level regulatory citation showing why your piece of equipment is not subject to or exempt from the regulation. For example** if you have a stationary internal combustion engine that is not subject to 40 CFR 63, Subpart ZZZZ because it is an existing 2 stroke lean burn stationary RICE with a site rating of more than 500 brake HP located at a major source of HAP emissions, your citation would be 40 CFR 63.6590(b)(3)(i). **We don't want a discussion of every non-applicable regulation, but if it is possible a regulation could apply, explain why it does not. For example**, if your facility is a power plant, you do not need to include a citation to show that 40 CFR 60, Subpart OOO does not apply to your non-existent rock crusher.

### **Regulatory Citations for Emission Standards:**

**For each unit that is subject to an emission standard in a source specific regulation, such as 40 CFR 60, Subpart OOO or 40 CFR 63, Subpart HH, include the low level regulatory citation of that emission standard.** Emission standards can be numerical emission limits, work practice standards, or other requirements such as maintenance. **Here are examples:** a glycol dehydrator is subject to the general standards at 63.764C(1)(i) through (iii); an engine is subject to 63.6601, Tables 2a and 2b; a crusher is subject to 60.672(b), Table 3 and all transfer points are subject to 60.672(e)(1)

### **Federally Enforceable Conditions:**

All federal regulations are federally enforceable. All Air Quality Bureau State regulations are federally enforceable except for the following: affirmative defense portions at 20.2.7.6.B, 20.2.7.110(B)(15), 20.2.7.11 through 20.2.7.113, 20.2.7.115, and 20.2.7.116; 20.2.37; 20.2.42; 20.2.43; 20.2.62; 20.2.63; 20.2.86; 20.2.89; and 20.2.90 NMAC. Federally enforceable means that EPA can enforce the regulation as well as the Air Quality Bureau and federally enforceable regulations can count toward determining a facility's potential to emit (PTE) for the Title V, PSD, and nonattainment permit regulations.

INCLUDE ANY OTHER INFORMATION NEEDED TO COMPLETE AN APPLICABILITY DETERMINATION OR THAT IS RELEVANT TO YOUR FACILITY'S NOTICE OF INTENT OR PERMIT.

**EPA Applicability Determination Index for 40 CFR 60, 61, 63, etc:** <http://cfpub.epa.gov/adi/>

---

<u>STATE REGU- LATIONS CITATION</u>	<b>Title</b>	<b>Applies? Enter Yes or No</b>	<b>Unit(s) or Facility</b>	<b>JUSTIFICATION:  (You may delete instructions or statements that do not apply in the justification column to shorten the document.)</b>
20.2.1 NMAC	General Provisions	Yes	Facility	General Provisions apply to Notice of Intent, Construction, and Title V permit applications.
20.2.3 NMAC	Ambient Air Quality Standards NMAAQS	Yes	Facility	If subject, this would normally apply to the entire facility. 20.2.3 NMAC is a State Implementation Plan (SIP) approved regulation that limits the maximum allowable concentration of Total Suspended Particulates, Sulfur Compounds, Carbon Monoxide and Nitrogen Dioxide. Title V applications, see exemption at 20.2.3.9 NMAC
20.2.7 NMAC	Excess Emissions	Yes	Facility	If subject, this would normally apply to the entire facility. If your entire facility or individual pieces of equipment are subject to emissions limits in a permit or numerical emissions standards in a federal or state regulation, this applies. This would not apply to Notices of Intent since these are not permits.
20.2.33 NMAC	Gas Burning Equipment - Nitrogen Dioxide	No	N/A	None of the equipment has a rating greater than 1 MMBtu/hr.
20.2.34 NMAC	Oil Burning Equipment: NO <sub>2</sub>	No	N/A	This facility has no oil burning equipment.
20.2.35 NMAC	Natural Gas Processing Plant – Sulfur	No	N/A	The facility is not a gas processing plant.
20.2.38 NMAC	Hydrocarbon Storage Facility	Yes	OT1- OT4	The site uses a flare to comply with 20.2.38 NMAC.
20.2.39 NMAC	Sulfur Recovery Plant - Sulfur	No	N/A	The facility does not operate a sulfur recovery plant.
20.2.61.109 NMAC	Smoke & Visible Emissions	Yes	FL1-3, RB1-3, ENG1- 9, ENG11 -12, HTR1	This regulation that limits opacity to 20% applies to Stationary Combustion Equipment, such as engines, boilers, heaters, and flares unless your equipment is subject to another state regulation that limits particulate matter such as 20.2.19 NMAC (see 20.2.61.109 NMAC).
20.2.70 NMAC	Operating Permits	Yes	Facility	The facility is a major source and will apply for a Title V Operating Permit.
20.2.71 NMAC	Operating Permit Fees	Yes	Facility	The facility is a major source and will apply for a Title V Operating Permit.
20.2.72 NMAC	Construction Permits	Yes	Facility	This application requests a NSR in accordance with 20.2.72.
20.2.73 NMAC	NOI & Emissions Inventory Requirements	No	N/A	The site is subject to 20.2.72 NMAC.
20.2.74 NMAC	Permits – Prevention of Significant Deterioration (PSD)	No	N/A	The facility is not a major PSD site.
20.2.75 NMAC	Construction Permit Fees	Yes	Facility	A permit fee is included with this application.

<u>STATE REGU- LATIONS CITATION</u>	<b>Title</b>	<b>Applies? Enter Yes or No</b>	<b>Unit(s) or Facility</b>	<b>JUSTIFICATION:  (You may delete instructions or statements that do not apply in the justification column to shorten the document.)</b>
20.2.77 NMAC	New Source Performance	Yes	Facility	See regulatory discussion in Federal Regulations Citation section.
20.2.78 NMAC	Emission Standards for HAPS	No	N/A	The facility does not fit into any of the source categories.
20.2.79 NMAC	Permits – Nonattainment Areas	No	N/A	The facility is not located in a nonattainment area.
20.2.80 NMAC	Stack Heights	No	N/A	There are no stacks to which this regulation would apply.
20.2.82 NMAC	MACT Standards for source categories of HAPS	Yes	DEHY1- 3, ENG1-9, ENG11- 12	See regulatory discussion in Federal Regulations Citation section.
20.2.1 NMAC	General Provisions	Yes	Facility	General Provisions apply to Notice of Intent, Construction, and Title V permit applications.
20.2.3 NMAC	Ambient Air Quality Standards NMAAQS	Yes	Facility	If subject, this would normally apply to the entire facility. 20.2.3 NMAC is a State Implementation Plan (SIP) approved regulation that limits the maximum allowable concentration of Total Suspended Particulates, Sulfur Compounds, Carbon Monoxide and Nitrogen Dioxide. Title V applications, see exemption at 20.2.3.9 NMAC

<u>FEDERAL REGU- LATIONS CITATION</u>	<b>Title</b>	<b>Applies? Enter Yes or No</b>	<b>Unit(s) or Facility</b>	<b>JUSTIFICATION:</b>
40 CFR 50	NAAQS	Yes	Facility	Compliance with the requirements of the GCP indicates compliance with NAAQS.
NSPS 40 CFR 60, Subpart A	General Provisions	Yes	Facility	See regulatory discussion below.
NSPS 40 CFR60.40a, Subpart Da	Subpart Da, Performance Standards for Electric Utility Steam Generating Units	No	N/A	The facility does not operate any electric utility steam generating units.
NSPS 40 CFR60.40b Subpart Db	Electric Utility Steam Generating Units	No	N/A	The facility does not operate any electric utility steam generating units.

<b>FEDERAL REGU- LATIONS CITATION</b>	<b>Title</b>	<b>Applies? Enter Yes or No</b>	<b>Unit(s) or Facility</b>	<b>JUSTIFICATION:</b>
NSPS 40 CFR 60, Subpart Ka	Storage Vessels for Petroleum Liquids Commenced After May 18, 1978, and Prior to July 23, 1984	No	N/A	The hydrocarbons are stored prior to custody transfer.
NSPS 40 CFR 60, Subpart Kb	Standards of Performance for Volatile Organic Liquid Storage Commenced After July 23, 1984	No	N/A	The hydrocarbons are stored prior to custody transfer.
NSPS 40 CFR 60.330 Subpart GG	Stationary Gas Turbines	No	N/A	There are no turbines.
NSPS 40 CFR 60, Subpart KKK	Leaks of VOC from Onshore Gas Plants	No	N/A	This is not a gas plant.
NSPS 40 CFR Part 60 Subpart LLL	Standards of Performance for Onshore Natural Gas Processing: SO2 Emissions	No	N/A	The facility does not operate a sweetening unit.
NSPS 40 CFR Part 60 Subpart OOOO	Crude Oil and Natural Gas Production, Transmission, and Distribution after August 23, 2011 and before September 18, 2015	No	N/A	The site will be constructed after 9/18/15. See NSPS OOOOa discussion below.
NSPS 40 CFR Part 60 Subpart OOOOa	Crude Oil and Natural Gas Facilities for which Construction, Modification or Reconstruction Commenced After September 18, 2015	Yes	FUG	The storage tanks were constructed after the applicability date of the rule; however, XTO is requesting emissions be limited by permit to less than 6 tpy. The regulation is applicable to the storage tanks but the tanks are not affected sources. The site uses low-bleed pneumatic controllers. The site is subject to leak monitoring from fugitive components.
NSPS 40 CFR 60 Subpart IIII	Standards of performance for Stationary Compression Ignition Internal Combustion Engines	No	N/A	The facility does not operate any affected sources.
NSPS 40 CFR Part 60 Subpart JJJJ	Standards of Performance for Stationary Spark Ignition Internal Combustion Engines	TBD	ENG1-9, ENG11- 12	ENG1-ENG3 are subject to the engines are subject to the limitations in Table 1 per 40 CFR 60.4233(e). A determination of applicability will be made for each engine to be used at the site.

<b>FEDERAL REGU- LATIONS CITATION</b>	<b>Title</b>	<b>Applies? Enter Yes or No</b>	<b>Unit(s) or Facility</b>	<b>JUSTIFICATION:</b>
NSPS 40 CFR 60 Subpart TTTT	Greenhouse Gas Emissions for Electric Generating Units	No	N/A	The facility does not operate any affected sources.
NSPS 40 CFR 60 Subpart UUUU	Greenhouse Gas Emissions and Compliance Times for Electric Utility Generating Units	No	N/A	The facility does not operate any affected sources.
NSPS 40 CFR 60, Subparts WWW, XXX, Cc, and Cf	Standards of performance for Municipal Solid Waste (MSW) Landfills	No	N/A	The facility does not operate any affected sources.
NESHAP 40 CFR 61 Subpart A	General Provisions	See Below	See Below	See regulatory discussion below.
NESHAP 40 CFR 61 Subpart E	National Emission Standards for Mercury	No	N/A	The facility does not operate any affected sources.
NESHAP 40 CFR 61 Subpart V	National Emission Standards for Equipment Leaks (Fugitive Emission Sources)	No	N/A	The facility does not operate any affected sources.
MACT 40 CFR 63, Subpart A	General Provisions	No	N/A	See regulatory discussion below.
MACT 40 CFR 63.760 Subpart HH	Oil and Natural Gas Production Facilities	Yes	DEHY1- 3	As a major source of HAP, sources subject to HH include storage vessels with flash emissions, fugitive components, and compressors in VHAP service ((see §63.760(b)(1)(ii), (iii), and (iv)). Fugitives and compressors are exempt per §63.769(b) since they are subject to NSPS OOOO. Storage vessels use a closed vent system connected to a combustor to comply with §63.766(b). The dehydrators process more than 3 mmscfd; however, since benzene emissions are less than 1 tpy, there are no applicable requirements. (See §63.764(E)(1))
MACT 40 CFR 63 Subpart HHH	Natural Gas Transmission and Storage Facilities	No	N/A	This regulation does not apply as the plant is not a natural gas transmission and storage facility as defined by the subpart (§63.1270(a)).
MACT 40 CFR 63 Subpart DDDDD	Major Industrial, Commercial, and Institutional Boilers & Process Heaters	No	N/A	The facility is not a major source of HAP as defined in §63.7575 "Major source for oil and natural gas production facilities". Therefore, MACT 40 CFR 63 Subpart DDDDD does not apply.
MACT 40 CFR 63 Subpart JJJJJ	Boilers and Process Heaters	No	N/A	The units are exempt per §63.1195(e) since they burn natural gas.
MACT 40 CFR 63 Subpart UUUUU	NESHAP Coal & Oil Fire Electric Utility Steam Generating Unit	No	N/A	The facility does not operate any affected sources.
MACT 40 CFR 63 Subpart ZZZZ	RICE MACT	TBD	ENG1-9, ENG11- 12	ENG1-ENG3 comply with NSPS JJJJ to comply with NESHAP ZZZZ per 60.6590(c)(1). A determination of applicability will be made for each engine to be used at the site.

<b>FEDERAL REGU- LATIONS CITATION</b>	<b>Title</b>	<b>Applies? Enter Yes or No</b>	<b>Unit(s) or Facility</b>	<b>JUSTIFICATION:</b>
40 CFR 64	Compliance Assurance Monitoring	No	N/A	The facility is not subject to CAM.
40 CFR 68	Chemical Accident Prevention	No	N/A	The facility does not store any chemicals above threshold quantities.
Acid Rain 40 CFR 72	Acid Rain	No	N/A	The facility does not have any units subject to the Acid Rain regulations.
Title IV – Acid Rain 40 CFR 73	Sulfur Dioxide Allowance Emissions	No	N/A	The facility does not have any units subject to the Acid Rain regulations.
Title IV-Acid Rain 40 CFR 75	Continuous Emissions Monitoring	No	N/A	The facility does not have any units subject to the Acid Rain regulations.
Title IV – Acid Rain 40 CFR 76	Acid Rain Nitrogen Oxides Emission Reduction Program	No	N/A	The facility does not have any units subject to the Acid Rain regulations.
Title VI – 40 CFR 82	Protection of Stratospheric Ozone	No	N/A	The facility does not service, maintain, or repair equipment containing refrigerants.



**Tab 14**

**Section 14 - Operational Plan to Mitigate Emissions**

# Section 14

## Operational Plan to Mitigate Emissions

(Submitting under 20.2.70, 20.2.72, 20.2.74 NMAC)

---

- Title V Sources** (20.2.70 NMAC): By checking this box and certifying this application the permittee certifies that it has developed an **Operational Plan to Mitigate Emissions During Startups, Shutdowns, and Emergencies** defining the measures to be taken to mitigate source emissions during startups, shutdowns, and emergencies as required by 20.2.70.300.D.5(f) and (g) NMAC. This plan shall be kept on site to be made available to the Department upon request. This plan should not be submitted with this application.
- NSR** (20.2.72 NMAC), **PSD** (20.2.74 NMAC) & **Nonattainment** (20.2.79 NMAC) **Sources:** By checking this box and certifying this application the permittee certifies that it has developed an **Operational Plan to Mitigate Source Emissions During Malfunction, Startup, or Shutdown** defining the measures to be taken to mitigate source emissions during malfunction, startup, or shutdown as required by 20.2.72.203.A.5 NMAC. This plan shall be kept on site to be made available to the Department upon request. This plan should not be submitted with this application.
- Title V** (20.2.70 NMAC), **NSR** (20.2.72 NMAC), **PSD** (20.2.74 NMAC) & **Nonattainment** (20.2.79 NMAC) **Sources:** By checking this box and certifying this application the permittee certifies that it has established and implemented a Plan to Minimize Emissions During Routine or Predictable Startup, Shutdown, and Scheduled Maintenance through work practice standards and good air pollution control practices as required by 20.2.7.14.A and B NMAC. This plan shall be kept on site or at the nearest field office to be made available to the Department upon request. This plan should not be submitted with this application.
- 

Emissions during startups, shutdowns, maintenance and emergencies (ESDs) will be minimized through the application of industry standards and /or manufacturer recommended operating practices as described below. Trained technicians are responsible for the timely and effective implementation of these actions.

Startup procedures for the engines are normally completed in less than 15 minutes and shutdown procedures are normally completed in less than 5 minutes. During a cold startup, the units may emit at a higher rate than normal as the units warm to operating temperature; however, if the unit has been shut down for long enough that a warm up is required, the small excess emissions occurring during warmup will be more than offset by the lack of emissions during the shutdown period. Similarly, if the unit is restarted while warm, there should be no excess emissions as the unit is already at operating temperature.

**Tab 15**  
**Section 15 - Alternative Operating Scenarios**

# Section 15

## Alternative Operating Scenarios

(Submitting under 20.2.70, 20.2.72, 20.2.74 NMAC)

---

**Alternative Operating Scenarios:** Provide all information required by the department to define alternative operating scenarios. This includes process, material and product changes; facility emissions information; air pollution control equipment requirements; any applicable requirements; monitoring, recordkeeping, and reporting requirements; and compliance certification requirements. Please ensure applicable Tables in this application are clearly marked to show alternative operating scenario.

**Construction Scenarios:** When a permit is modified authorizing new construction to an existing facility, NMED includes a condition to clearly address which permit condition(s) (from the previous permit and the new permit) govern during the interval between the date of issuance of the modification permit and the completion of construction of the modification(s). There are many possible variables that need to be addressed such as: Is simultaneous operation of the old and new units permitted and, if so for example, for how long and under what restraints? In general, these types of requirements will be addressed in Section A100 of the permit, but additional requirements may be added elsewhere. Look in A100 of our NSR and/or TV permit template for sample language dealing with these requirements. Find these permit templates at: [https://www.env.nm.gov/aqb/permit/aqb\\_pol.html](https://www.env.nm.gov/aqb/permit/aqb_pol.html). Compliance with standards must be maintained during construction, which should not usually be a problem unless simultaneous operation of old and new equipment is requested.

In this section, under the bolded title “Construction Scenarios”, specify any information necessary to write these conditions, such as: conservative-realistic estimated time for completion of construction of the various units, whether simultaneous operation of old and new units is being requested (and, if so, modeled), whether the old units will be removed or decommissioned, any PSD ramifications, any temporary limits requested during phased construction, whether any increase in emissions is being requested as SSM emissions or will instead be handled as a separate Construction Scenario (with corresponding emission limits and conditions, etc).

---

XTO is not proposing any alternative operating scenarios.

**Tab 16**  
**Section 16 - Air Dispersion Modeling**

# Section 16

## Air Dispersion Modeling

- 1) Minor Source Construction (20.2.72 NMAC) and Prevention of Significant Deterioration (PSD) (20.2.74 NMAC) ambient impact analysis (modeling): Provide an ambient impact analysis as required at 20.2.72.203.A(4) and/or 20.2.74.303 NMAC and as outlined in the Air Quality Bureau’s Dispersion Modeling Guidelines found on the Planning Section’s modeling website. If air dispersion modeling has been waived for one or more pollutants, attach the AQB Modeling Section modeling waiver approval documentation.
- 2) SSM Modeling: Applicants must conduct dispersion modeling for the total short term emissions during routine or predictable startup, shutdown, or maintenance (SSM) using realistic worst case scenarios following guidance from the Air Quality Bureau’s dispersion modeling section. Refer to "Guidance for Submittal of Startup, Shutdown, Maintenance Emissions in Permit Applications ([http://www.env.nm.gov/aqb/permit/app\\_form.html](http://www.env.nm.gov/aqb/permit/app_form.html)) for more detailed instructions on SSM emissions modeling requirements.
- 3) Title V (20.2.70 NMAC) ambient impact analysis: Title V applications must specify the construction permit and/or Title V Permit number(s) for which air quality dispersion modeling was last approved. Facilities that have only a Title V permit, such as landfills and air curtain incinerators, are subject to the same modeling required for preconstruction permits required by 20.2.72 and 20.2.74 NMAC.

What is the purpose of this application?	Enter an X for each purpose that applies
New PSD major source or PSD major modification (20.2.74 NMAC). See #1 above.	
New Minor Source or significant permit revision under 20.2.72 NMAC (20.2.72.219.D NMAC). See #1 above. <b>Note:</b> Neither modeling nor a modeling waiver is required for VOC emissions.	X
Reporting existing pollutants that were not previously reported.	
Reporting existing pollutants where the ambient impact is being addressed for the first time.	
Title V application (new, renewal, significant, or minor modification. 20.2.70 NMAC). See #3 above.	
Relocation (20.2.72.202.B.4 or 72.202.D.3.c NMAC)	
Minor Source Technical Permit Revision 20.2.72.219.B.1.d.vi NMAC for like-kind unit replacements.	
Other: i.e. SSM modeling. See #2 above.	
This application does not require modeling since this is a No Permit Required (NPR) application.	
This application does not require modeling since this is a Notice of Intent (NOI) application (20.2.73 NMAC).	
This application does not require modeling according to 20.2.70.7.E(11), 20.2.72.203.A(4), 20.2.74.303, 20.2.79.109.D NMAC and in accordance with the Air Quality Bureau’s Modeling Guidelines.	

**Check each box that applies:**

- See attached, approved modeling **waiver for all** pollutants from the facility.
- See attached, approved modeling **waiver for some** pollutants from the facility.
- Attached in Universal Application Form 4 (UA4) is a **modeling report for all** pollutants from the facility.
- Attached in UA4 is a **modeling report for some** pollutants from the facility.
- No modeling is required.

**Tab 17**  
**Section 17 - Compliance Test History**

# Section 17

## Compliance Test History

(Submitting under 20.2.70, 20.2.72, 20.2.74 NMAC)

---

To show compliance with existing NSR permits conditions, you must submit a compliance test history. The table below provides an example.

---

No tests have been performed.



**Tab 18**

**Section 18 - Addendum for Streamline Applications  
(Not Applicable)**

# Section 18

## Addendum for Streamline Applications

Do not print this section unless this is a streamline application.

---

**Streamline Applications do not require a complete application. Submit Sections 1-A, 1-B, 1-D, 1-F, 1-G, 2-A, 2-C thru L, Sections 3 thru 8, Section 13, Section 18, Section 22, and Section 23 (Certification). Other sections may be required at the discretion of the Department. 20.2.72.202 NMAC Exemptions do not apply to Streamline sources. 20.2.72.219 NMAC revisions and modifications do not apply to Streamline sources, thus 20.2.72.219 type actions require a complete new application submittal. Please do not print sections of a streamline application that are not required.**

---

This section is not applicable since this is not a Streamline Permit Application.

**Tab 19**

**Section 19 - Requirements for Title V Program**

# Section 19

## Requirements for Title V Program

Do not print this section unless this is a Title V application.

---

### Who Must Use this Attachment:

- \* Any major source as defined in 20.2.70 NMAC.
  - \* Any source, including an area source, subject to a standard or other requirement promulgated under Section 111 - Standards of Performance for New Stationary Sources, or Section 112 Hazardous Air Pollutants, of the 1990 federal Clean Air Act ("federal Act"). Non-major sources subject to Sections 111 or 112 of the federal Act are exempt from the obligation to obtain an 20.2.70 NMAC operating permit until such time that the EPA Administrator completes rulemakings that require such sources to obtain operating permits. In addition, sources that would be required to obtain an operating permit solely because they are subject to regulations or requirements under Section 112(r) of the federal Act are exempt from the requirement to obtain an Operating Permit.
  - \* Any Acid Rain source as defined under title IV of the federal Act. The Acid Rain program has additional forms. See <http://www.env.nm.gov/aqb/index.html>. Sources that are subject to both the Title V and Acid Rain regulations are encouraged to submit both applications simultaneously.
  - \* Any source in a source category designated by the EPA Administrator ("Administrator"), in whole or in part, by regulation, after notice and comment.
- 

This is not a Title V application.

**Tab 20**  
**Section 20 - Other Relevant Information**

# Section 20

## Other Relevant Information

---

**Other relevant information.** Use this attachment to clarify any part in the application that you think needs explaining. Reference the section, table, column, and/or field. Include any additional text, tables, calculations or clarifying information.

Additionally, the applicant may propose specific permit language for AQB consideration. In the case of a revision to an existing permit, the applicant should provide the old language and the new language in track changes format to highlight the proposed changes. If proposing language for a new facility or language for a new unit, submit the proposed operating condition(s), along with the associated monitoring, recordkeeping, and reporting conditions. In either case, please limit the proposed language to the affected portion of the permit.

---

No other relevant information is provided.

**Tab 21**

**Section 21 - Addendum for Landfill Applications  
(Not Applicable)**

# Section 21

## Addendum for Landfill Applications

Do not print this section unless this is a landfill application.

---

Landfill Applications are not required to complete Sections 1-C Input Capacity and Production Rate, 1-E Operating Schedule, 17 Compliance Test History, and 18 Streamline Applications. Section 12 – PSD Applicability is required only for Landfills with Gas Collection and Control Systems and/or landfills with other non-fugitive stationary sources of air emissions such as engines, turbines, boilers, heaters. All other Sections of the Universal Application Form are required.

EPA Background Information for MSW Landfill Air Quality Regulations:

<https://www3.epa.gov/airtoxics/landfill/landflpg.html>

NM Solid Waste Bureau Website: <https://www.env.nm.gov/swb/>

---

This is not a landfill.



**Tab 22**  
**Section 22 - Certification**

# Section 22: Certification

Company Name: XTO Energy Inc.

I, Benjamin Schneider, hereby certify that the information and data submitted in this application are true and as accurate as possible, to the best of my knowledge and professional expertise and experience.

Signed this 1 day of September 2020, upon my oath or affirmation, before a notary of the State of Illinois.

Benjamin Schneider  
\*Signature

9/1/2020  
Date

Benjamin Schneider  
Printed Name

Environmental Engineer  
Title

Scribed and sworn before me on this 1st day of September 2020.

My authorization as a notary of the State of Illinois expires on the 24 day of March, 2022.

Theresa Lay Chatham  
Notary's Signature

September 1 2020  
Date

Theresa Lay Chatham  
Notary's Printed Name

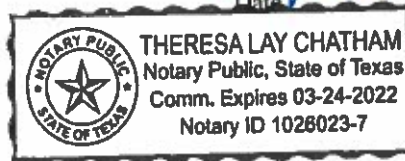

\*For Title V applications, the signature must be of the Responsible Official as defined in 20.2.70.7.AE NMAC.

**Tab 23**  
**Section 23 - UA4**

# Universal Application 4

## Air Dispersion Modeling Report

Refer to and complete Section 16 of the Universal Application form (UA3) to assist your determination as to whether modeling is required. If, after filling out Section 16, you are still unsure if modeling is required, e-mail the completed Section 16 to the AQB Modeling Manager for assistance in making this determination. If modeling is required, a modeling protocol would be submitted and approved prior to an application submittal. The protocol should be emailed to the modeling manager. A protocol is recommended but optional for minor sources and is required for new PSD sources or PSD major modifications. Fill out and submit this portion of the Universal Application form (UA4), the “Air Dispersion Modeling Report”, only if air dispersion modeling is required for this application submittal. This serves as your modeling report submittal and should contain all the information needed to describe the modeling. No other modeling report or modeling protocol should be submitted with this permit application.

### 16-A: Identification

1	Name of facility:	Bulldog Compressor Station
2	Name of company:	XTO Energy Inc.
3	Current Permit number:	8153
4	Name of applicant’s modeler:	Bruce Ferguson
5	Phone number of modeler:	(601) 824-1860
6	E-mail of modeler:	bferguson@fce-engineering.com

### 16-B: Brief

1	Was a modeling protocol submitted and approved?	Yes <input type="checkbox"/>	No <input checked="" type="checkbox"/>
2	Why is the modeling being done?	Other (describe below)	
3	Describe the permit changes relevant to the modeling.		
	<b>Change in facility equipment models, addition of flaring SSM emissions, facility location adjusted.</b>		
4	What geodetic datum was used in the modeling?	NAD83	
5	How long will the facility be at this location?	Indefinite	
6	Is the facility a major source with respect to Prevention of Significant Deterioration (PSD)?	Yes <input type="checkbox"/>	No <input checked="" type="checkbox"/>
7	Identify the Air Quality Control Region (AQCR) in which the facility is located	155	

**16-B: Brief**

8	List the PSD baseline dates for this region (minor or major, as appropriate).		
	NO2	3/16/1988	
	SO2	7/28/1978	
	PM10	2/20/1979	
	PM2.5	11/13/2013	
9	Provide the name and distance to Class I areas within 50 km of the facility (300 km for PSD permits).		
	None		
10	Is the facility located in a non-attainment area? If so describe below	Yes <input type="checkbox"/>	No <input checked="" type="checkbox"/>
11	Describe any special modeling requirements, such as streamline permit requirements.		
	None		

**16-C: Modeling History of Facility**

1	Describe the modeling history of the facility, including the air permit numbers, the pollutants modeled, the National Ambient Air Quality Standards (NAAQS), New Mexico AAQS (NMAAQs), and PSD increments modeled. (Do not include modeling waivers).			
	Pollutant	Latest permit and modification number that modeled the pollutant facility-wide.	Date of Permit	Comments
	CO	8153	5/7/2019	
	NO <sub>2</sub>	8153	5/7/2019	
	SO <sub>2</sub>	8153	5/7/2019	
	H <sub>2</sub> S			
	PM2.5	8153	5/7/2019	
	PM10	8153	5/7/2019	
	TSP			
	Lead			
	Ozone (PSD only)			
	NM Toxic Air Pollutants (20.2.72.402 NMAC)			

### 16-D: Modeling performed for this application

1	For each pollutant, indicate the modeling performed and submitted with this application. Choose the most complicated modeling applicable for that pollutant, i.e., culpability analysis assumes ROI and cumulative analysis were also performed.					
	Pollutant	ROI	Cumulative analysis	Culpability analysis	Waiver approved	Pollutant not emitted or not changed.
	CO	<input checked="" type="checkbox"/>	<input type="checkbox"/>	<input type="checkbox"/>	<input type="checkbox"/>	<input type="checkbox"/>
	NO <sub>2</sub>	<input checked="" type="checkbox"/>	<input checked="" type="checkbox"/>	<input type="checkbox"/>	<input type="checkbox"/>	<input type="checkbox"/>
	SO <sub>2</sub>	<input checked="" type="checkbox"/>	<input checked="" type="checkbox"/>	<input type="checkbox"/>	<input type="checkbox"/>	<input type="checkbox"/>
	H <sub>2</sub> S	<input type="checkbox"/>	<input type="checkbox"/>	<input type="checkbox"/>	<input type="checkbox"/>	<input checked="" type="checkbox"/>
	PM2.5	<input checked="" type="checkbox"/>	<input checked="" type="checkbox"/>	<input type="checkbox"/>	<input type="checkbox"/>	<input type="checkbox"/>
	PM10	<input checked="" type="checkbox"/>	<input checked="" type="checkbox"/>	<input type="checkbox"/>	<input type="checkbox"/>	<input type="checkbox"/>
	TSP*	<input type="checkbox"/>	<input type="checkbox"/>	<input type="checkbox"/>	<input type="checkbox"/>	<input type="checkbox"/>
	Lead	<input type="checkbox"/>	<input type="checkbox"/>	<input type="checkbox"/>	<input type="checkbox"/>	<input checked="" type="checkbox"/>
Ozone*	<input type="checkbox"/>	<input type="checkbox"/>	<input type="checkbox"/>	<input type="checkbox"/>	<input type="checkbox"/>	
State air toxic(s) (20.2.72.402 NMAC)	<input type="checkbox"/>	<input type="checkbox"/>	<input type="checkbox"/>	<input type="checkbox"/>	<input checked="" type="checkbox"/>	

\*Modeling was not performed for TSP because the standard was removed. Ozone was not evaluated because the permitting action is a minor NSR.

### 16-E: New Mexico toxic air pollutants modeling

1	List any New Mexico toxic air pollutants (NMTAPs) from Tables A and B in 20.2.72.502 NMAC that are modeled for this application. <p style="text-align: center;">None</p>					
2	List any NMTAPs that are emitted but not modeled because stack height correction factor. Add additional rows to the table below, if required.					
	Pollutant	Emission Rate (pounds/hour)	Emission Rate Screening Level (pounds/hour)	Stack Height (meters)	Correction Factor	Emission Rate/Correction Factor
	N/A					

### 16-F: Modeling options

1	Was the latest version of AERMOD used with regulatory default options? If not explain below.	Yes <input checked="" type="checkbox"/>	No <input type="checkbox"/>

**16-G: Surrounding source modeling**

1	Date of surrounding source retrieval	March 11, 2020, MergeMaster File Spoke with Eric Peters by phone 8/19/20, and Eric relayed that the 3/11/20 was the best available data and could be used.	
2	If the surrounding source inventory provided by the Air Quality Bureau was believed to be inaccurate, describe how the sources modeled differ from the inventory provided. If changes to the surrounding source inventory were made, use the table below to describe them. Add rows as needed.		
	AQB Source ID	Description of Corrections	
	Various	All neighboring sources within 10 km were retained for cumulative modeling. Neighboring sources between 10 and 25 km with source IDs less than 10,000 were removed from the inventory.	
	Various	None of the neighboring sources were found to have emissions of 1000 lb/hr or greater and neighboring sources greater than 25 km were removed from the inventory.	

**16-H: Building and structure downwash**

1	How many buildings are present at the facility?	No buildings.	
2	How many above ground storage tanks are present at the facility?	There are eight above ground storage tanks.	
3	Was building downwash modeled for all buildings and tanks? If not explain why below.	Yes <input checked="" type="checkbox"/>	No <input type="checkbox"/>
4	Building comments	N/A	

**16-I: Receptors and modeled property boundary**

1	<p>“Restricted Area” is an area to which public entry is effectively precluded. Effective barriers include continuous fencing, continuous walls, or other continuous barriers approved by the Department, such as rugged physical terrain with a steep grade that would require special equipment to traverse. If a large property is completely enclosed by fencing, a restricted area within the property may be identified with signage only. Public roads cannot be part of a Restricted Area. A Restricted Area is required in order to exclude receptors from the facility property. If the facility does not have a Restricted Area, then receptors shall be placed within the property boundaries of the facility.</p>					
	<p>Describe the fence or other physical barrier at the facility that defines the restricted area.</p> <p>No fence line was used. Modeling was conducted with on-site receptors at 10 m spacing.</p>					
2	Receptors must be placed along publicly accessible roads in the restricted area. Are there public roads passing through the restricted area?	Yes <input type="checkbox"/>	No <input checked="" type="checkbox"/>			
3	Are restricted area boundary coordinates included in the modeling files?	Yes <input type="checkbox"/>	No <input checked="" type="checkbox"/>			
4	Describe the receptor grids and their spacing. The table below may be used, adding rows as needed.					
	Grid Type	Shape	Spacing	Start distance from restricted area or center of facility	End distance from restricted area or center of facility	Comments
	Cartesian	Circle	10 m	0	250 m	
	Cartesian	Circle	50 m	250 m	1 km	
	Cartesian	Circle	100 m	1 km	3 km	
	Cartesian	Circle	250 m	3 km	6 km	
	Cartesian	Circle	500 m	6 km	10 km	
5	Describe receptor spacing along the fence line.					
	No fence line was used. Receptors were placed on-site at 10-meter spacings					
6	Describe the PSD Class I area receptors.					
	None					

**16-J: Sensitive areas**

1	Are there schools or hospitals or other sensitive areas near the facility? If so describe below. This information is optional (and purposely undefined) but may help determine issues related to public notice.	Yes <input type="checkbox"/>	No <input checked="" type="checkbox"/>
3	The modeling review process may need to be accelerated if there is a public hearing. Are there likely to be public comments opposing the permit application?	Yes <input type="checkbox"/>	No <input checked="" type="checkbox"/>



<b>16-K: Modeling Scenarios</b>												
1	Identify, define, and describe all modeling scenarios. Examples of modeling scenarios include using different production rates, times of day, times of year, simultaneous or alternate operation of old and new equipment during transition periods, etc. Alternative operating scenarios should correspond to all parts of the Universal Application and should be fully described in Section 15 of the Universal Application (UA3).											
	Three scenarios were included for flaring: flaring under normal operations, flaring for SSM events and all flare emissions distributed evenly between the two facility flares.											
2	Which scenario produces the highest concentrations? Why?											
	There were essentially no differences in the scenarios, indicating that the flares are not the controlling factor for the maximum ground level impacts.											
3	Were emission factor sets used to limit emission rates or hours of operation? (This question pertains to the "SEASON", "MONTH", "HROFDY" and related factor sets, not to the factors used for calculating the maximum emission rate.)	Yes <input type="checkbox"/>	No <input checked="" type="checkbox"/>									
4	If so, describe factors for each group of sources. List the sources in each group before the factor table for that group. (Modify or duplicate table as necessary. It's ok to put the table below section 16-K if it makes formatting easier.) Sources:											
5	Hour of Day	Factor	Hour of Day	Factor								
	1		13									
	2		14									
	3		15									
	4		16									
	5		17									
	6		18									
	7		19									
	8		20									
	9		21									
	10		22									
	11		23									
	12		24									
If hourly, variable emission rates were used that were not described above, describe them below.												
6	Were different emission rates used for short-term and annual modeling? If so describe below.	Yes <input type="checkbox"/>	No <input checked="" type="checkbox"/>									

<b>16-L: NO<sub>2</sub> Modeling</b>			
1	Which types of NO <sub>2</sub> modeling were used? Check all that apply.		
	<input checked="" type="checkbox"/>	ARM2	
	<input type="checkbox"/>	100% NO <sub>x</sub> to NO <sub>2</sub> conversion	
	<input type="checkbox"/>	PVMRM	
	<input type="checkbox"/>	OLM	
	<input type="checkbox"/>	Other:	
2	Describe the NO <sub>2</sub> modeling.		
	The modeled scenarios were modeled in separate runs for NO <sub>x</sub> instead of using source groups. The use of source groups with ARM2 underestimates the NO <sub>2</sub> impacts when the sources cannot operate simultaneously.		
3	Were default NO <sub>2</sub> /NO <sub>x</sub> ratios (0.5 minimum, 0.9 maximum or equilibrium) used? If not describe and justify the ratios used below.	Yes <input checked="" type="checkbox"/>	No <input type="checkbox"/>
4	Describe the design value used for each averaging period modeled.		
	1-hour: High eighth high Annual: One Year Annual Average		

<b>16-M: Particulate Matter Modeling</b>				
1	Select the pollutants for which plume depletion modeling was used.			
	<input type="checkbox"/>	PM2.5		
	<input type="checkbox"/>	PM10		
	<input checked="" type="checkbox"/>	None		
2	Describe the particle size distributions used. Include the source of information.			
	N/A			
3	Does the facility emit at least 40 tons per year of NO <sub>x</sub> or at least 40 tons per year of SO <sub>2</sub> ? Sources that emit at least 40 tons per year of NO <sub>x</sub> or at least 40 tons per year of SO <sub>2</sub> are considered to emit significant amounts of precursors and must account for secondary formation of PM2.5.		Yes <input checked="" type="checkbox"/> No <input type="checkbox"/>	
4	Was secondary PM modeled for PM2.5?		Yes <input type="checkbox"/> No <input checked="" type="checkbox"/>	
5	If MERPs were used to account for secondary PM2.5 fill out the information below. If another method was used describe below.			
	NO <sub>x</sub> (ton/yr)	SO <sub>2</sub> (ton/yr)	[PM2.5] <sub>annual</sub>	
	205.38 (including SSM)	4.51 (including SSM)	0.004 ug/m <sup>3</sup>	
	Southwest Climate Zone Lowest MERPs			
	State	County	Metric	Precursor
	Colorado	Weld Co	Annual PM <sub>2.5</sub>	NO <sub>x</sub>
Colorado	Weld Co	Annual PM <sub>2.5</sub>	SO <sub>2</sub>	
Colorado	Weld Co	Daily PM <sub>2.5</sub>	NO <sub>x</sub>	
Colorado	Weld Co	Daily PM <sub>2.5</sub>	SO <sub>2</sub>	
	$[PM2.5]_{annual} = SIL \times [NO_x \text{ Annual Emissions}/10530 + SO_2 \text{ Annual Emissions}/7359]$ $= (0.2 \text{ ug/m}^3)[(205.38/10530) + (4.51/7359)]$ $= 0.004 \text{ ug/m}^3$			
	$[PM2.5]_{24-hour} = SIL \times [NO_x \text{ Annual Emissions}/5215 + SO_2 \text{ Annual Emissions}/814]$ $= (1.2 \text{ ug/m}^3)[(205.38/5215)+(4.51/814)]$ $= 0.054 \text{ ug/m}^3$			

<b>16-N: Setback Distances</b>	
1	Portable sources or sources that need flexibility in their site configuration requires that setback distances be determined between the emission sources and the restricted area boundary (e.g. fence line) for both the initial location and future locations. Describe the setback distances for the initial location.
	None
2	Describe the requested, modeled, setback distances for future locations, if this permit is for a portable stationary source. Include a haul road in the relocation modeling.
	N/A

**16-O: PSD Increment and Source IDs**

1	The unit numbers in the Tables 2-A, 2-B, 2-C, 2-E, 2-F, and 2-I should match the ones in the modeling files. Do these match? If not, provide a cross-reference table between unit numbers if they do not match below.				Yes <input checked="" type="checkbox"/>	No <input type="checkbox"/>
	Unit Number in UA-2		Unit Number in Modeling Files			
	FL1	FL1_Normal (Normal Operating Emissions scenario)				
		FL1_SSM (SSM scenario)				
		FL1_Even (All flare emissions distributed evenly)				
	FL2	FL2_Normal (Normal Operating Emissions scenario)				
FL2_SSM (SSM scenario)						
FL2_Even (All flare emissions distributed evenly)						
2	The emission rates in the Tables 2-E and 2-F should match the ones in the modeling files. Do these match? If not, explain why below.				Yes <input checked="" type="checkbox"/>	No <input type="checkbox"/>
	Normal operations match 2-E. SSM matches 2-F. Flare emissions from 2-E and 2-F were also evenly distributed across the two flares, this should produce the maximum flaring emissions as it would result in the maximum emissions at the lowest plume rise.					
3	Have the minor NSR exempt sources or Title V Insignificant Activities" (Table 2-B) sources been modeled?				Yes <input checked="" type="checkbox"/>	No <input type="checkbox"/>
4	Which units consume increment for which pollutants?					
	Unit ID	NO <sub>2</sub>	SO <sub>2</sub>	PM10	PM2.5	
	All Facility Units	X	X	X	X	
5	PSD increment description for sources. (for unusual cases, i.e., baseline unit expanded emissions after baseline date).			N/A		
6	Are all the actual installation dates included in Table 2A of the application form, as required? This is necessary to verify the accuracy of PSD increment modeling. If not please explain how increment consumption status is determined for the missing installation dates below.				Yes <input checked="" type="checkbox"/>	No <input type="checkbox"/>
	Facility has not begun construction					

**16-P: Flare Modeling**

1	For each flare or flaring scenario, complete the following			
	Flare ID (and scenario)	Average Molecular Weight	Gross Heat Release (cal/s)	Effective Flare Diameter (m)
	FL1_Normal	43.98	1,107,992	0.869
	FL1_SSM	21.20	169,394	0.363
	FL1_Even	22.58	138,014,571	10.322
	FL2_Normal	21.20	169,394	0.363
	FL2_SSM	22.53	274,921,149	14.570
	FL2_Even	22.58	138,014,571	10.322

**16-Q: Volume and Related Sources**

1	Were the dimensions of volume sources different from standard dimensions in the Air Quality Bureau (AQB) Modeling Guidelines?	Yes <input type="checkbox"/>	No <input checked="" type="checkbox"/>
2	Describe the determination of sigma-Y and sigma-Z for fugitive sources. Values for large trucks in the NMED Guideline		
3	Describe how the volume sources are related to unit numbers. Or say they are the same. Unit No. ROAD represented by L0000001 through L0000024		
4	Describe any open pits. None		
5	Describe emission units included in each open pit. None		

**16-R: Background Concentrations**

1	Were NMED provided background concentrations used? Identify the background station used below. If non-NMED provided background concentrations were used describe the data that was used.	Yes <input checked="" type="checkbox"/>	No <input type="checkbox"/>
	CO: Del Norte High School (350010023)		
	NO <sub>2</sub> : Hobbs-Jefferson (350250008)		
	PM <sub>2.5</sub> : Hobbs-Jefferson (350450019)		
	PM <sub>10</sub> : Hobbs-Jefferson (350250008)		
	SO <sub>2</sub> : Amarillo (483751025)		
	Other:		
	Comments:		
2	Were background concentrations refined to monthly or hourly values? If so describe below.	Yes <input type="checkbox"/>	No <input checked="" type="checkbox"/>

**16-S: Meteorological Data**

1	Was NMED provided meteorological data used? If so select the station used. Artesia Year 2015	Yes <input checked="" type="checkbox"/>	No <input type="checkbox"/>
2	If NMED provided meteorological data was not used describe the data set(s) used below. Discuss how missing data were handled, how stability class was determined, and how the data were processed. N/A		

**16-T: Terrain**

1	Was complex terrain used in the modeling? If not, describe why below.	Yes <input checked="" type="checkbox"/>	No <input type="checkbox"/>
2	What was the source of the terrain data? NED data through <a href="http://www.webgis.com/">http://www.webgis.com/</a> , downloaded through the Lakes Environmental GUI		

**16-U: Modeling Files**

1	Describe the modeling files:		
	File name (or folder and file name)	Pollutant(s)	Purpose (ROI/SIA, cumulative, culpability analysis, other)
	SIA\NOx\ NOx_Normal.zip	NO2	ROI and Cumulative analysis
	NOx_SSM.zip		Normal Operating Scenario
	NOx_Even.zip		SSM Scenario
	SIA\CO.zip	CO	SSM Flare Emission evenly distributed to both flares
	SIA\SO2.zip	SO2	ROI
	SIA\PM10.zip	PM10	ROI & Cumulative
	SIA\PM25.zip	PM2.5	ROI
	CIA\PM10.zip	PM10	Cumulative
	CIA\PM25.zip	PM2.5	Cumulative
	Generic zip file contents are summarized below		
Artesia-Midland_2015.PFL & .SFC	Met Data as downloaded from NMED		
Pages from A-8153_UA Calculations_XTO Bulldog CS NSR_07.11.20 - Bruce.jpg, .wdt	Georeferenced facility layout		
Surrounding Sources\ MERCs table_export.xlsx	Surrounding source files generated by MergeMaster MERCs downloaded from EPA for Southwest Climate Zone		
[Pollutant].ADI	AERMOD input file		
[Pollutant].ADO	AERMOD output file		
[Pollutant].sum	AERMOD output summary file		
[Pollutant].bpi	BPIP input file		
[Pollutant].pro	BPIP output file		
\[Pollutant].AD\ [Avg Period][Rank]G[xxx].PLT	Plot File Directory Plot file naming convention. Where facility source groups were used G001 denotes normal operation, G002 denotes SSM operations and G003 denotes flaring evenly distributed between flares. For PM10 & PM2.5 cumulative G001 denotes NAAQS modeling and G002 denotes PSD increment modeling.		

**16-V: PSD New or Major Modification Applications (Not Applicable)**

1	A new PSD major source or a major modification to an existing PSD major source requires additional analysis. Was preconstruction monitoring done (see 20.2.74.306 NMAC and PSD Preapplication Guidance on the AQB website)?	Yes <input type="checkbox"/>	No <input type="checkbox"/>
2	If not, did AQB approve an exemption from preconstruction monitoring?	Yes <input type="checkbox"/>	No <input type="checkbox"/>
3	Describe how preconstruction monitoring has been addressed or attach the approved preconstruction monitoring or monitoring exemption.		
4	Describe the additional impacts analysis required at 20.2.74.304 NMAC.		
5	If required, have ozone and secondary PM2.5 ambient impacts analyses been completed? If so describe below.	Yes <input type="checkbox"/>	No <input type="checkbox"/>

### 16-W: Modeling Results

1	If ambient standards are exceeded because of surrounding sources, a culpability analysis is required for the source to show that the contribution from this source is less than the significance levels for the specific pollutant. Was culpability analysis performed? If so describe below.	Yes <input type="checkbox"/>	No <input checked="" type="checkbox"/>
---	---	------------------------------	--

2	Identify the maximum concentrations from the modeling analysis. Rows may be modified, added and removed from the table below as necessary.
---	--

Pollutant, Time Period and Standard	Modeled Facility Concentration (µg/m <sup>3</sup> )	Modeled Concentration with Surrounding Sources	Secondary PM (µg/m <sup>3</sup> )	Background Concentration (µg/m <sup>3</sup> )	Cumulative Concentration (µg/m <sup>3</sup> )	Value of Standard (µg/m <sup>3</sup> )	Percent of Standard	Location		
								UTM E (m)	UTM N (m)	Elevation (ft)
CO 1hr NMAAQs	188.85719	N/A	N/A	2,203	2,391.86	9,960.1	24%	607740	3602720	3,497
CO 8hr NMAAQs	101.16457	N/A	N/A	1,524	1,625.16	14,997.5	11%	607740	3602740	3,497
NO <sub>2</sub> 1hr NAAQS	108.45874	N/A	N/A	64.2	172.66	188.03	92%	607750	3602780	3,497
NO <sub>2</sub> Annual NMAAQs	10.99693	N/A	N/A	8.1	19.10	94.02	20%	607360	3602760	3,499
SO <sub>2</sub> 1hr NAAQS	14.48833	N/A	N/A	47.0	61.49	196.4	31%	607760	3602760	3,499
SO <sub>2</sub> Annual NMAAQs	1.47230	N/A	N/A	0.670	2.14	52.4	4%	607360	3602760	3,499
SO <sub>2</sub> Annual PSD	1.47230	N/A	N/A	0.670	2.14	20	11%	607360	3602760	3,499
PM <sub>10</sub> 24hr NAAQS		5.17563	N/A	37.3	42.48	150	28%	607340	3602830	3,499
PM <sub>10</sub> 24hr PSD		4.74807	N/A	N/A	4.75	30	16%	607340	3602830	3,499
PM <sub>10</sub> Annual PSD		2.00135	N/A	N/A	2.00	17	12%	607370	3602790	3,499
PM <sub>2.5</sub> 24hr NAAQS		4.98135	0.054	13.4	18.44	35	53%	607530	3602510	3,503
PM <sub>2.5</sub> Annual NAAQS		1.52053	0.004	5.9	7.42	12	62%	607360	3602780	3,499
PM <sub>2.5</sub> 24hr PSD		3.29759	0.054	N/A	3.35	9	37%	607330	3602740	3,500
PM <sub>2.5</sub> Annual PSD		1.32172	0.004	N/A	1.33	4	33%	607360	3602780	3,499

**16-X: Summary/conclusions**

1	<p>A statement that modeling requirements have been satisfied and that the permit can be issued.</p> <p>A significant impact analysis was performed for pollutants identified in Section 16-D. CO impacts were found to be below the modeling significance level. Impacts for the remaining pollutants were found to be above the modeling significance level and a cumulative impact was required for these pollutants.</p> <p>PM<sub>10</sub> and PM<sub>2.5</sub> impacts from surrounding sources was accounted for by explicitly modeling all sources within 10 km of the project and all increment consuming sources within 25 km of the project. Existing air quality modeling values were added to the modeled PM<sub>10</sub> and PM<sub>2.5</sub> impacts to account for distant surrounding sources. Nearby and distant surrounding sources impacts for SO<sub>2</sub>, NO<sub>x</sub> and CO were accounted for in the analysis by using existing air quality monitoring in the area.</p> <p>The modeled impacts combined with the existing air quality in the area were found to be compliant with the ambient air quality standards, i.e., NAAQS, NMAAQs and PSD increment. The proposed project will not cause or contribute to an exceedance of the ambient air quality standards. The NMED modeling requirements have been satisfied and the permit can be issued.</p>
---	---