

**ATTACHMENT A2**  
**GEOLOGIC REPOSITORY**

(This page intentionally blank)

**ATTACHMENT A2**  
**GEOLOGIC REPOSITORY**

**TABLE OF CONTENTS**

|             |  |    |
|-------------|--|----|
| A2-1        | Description of the Geologic Repository .....               | 1  |
| A2-2        | Geologic Repository Design and Process Description .....   | 3  |
| A2-2a       | Geologic Repository Design and Construction .....          | 3  |
| A2-2a(1)    | CH TRU Mixed Waste Handling Equipment.....                 | 3  |
| A2-2a(2)    | Shafts .....   | 5  |
| A2-2a(3)    | Subsurface Structures .....                                | 7  |
| A2-2a(4)    | RH TRU Mixed Waste Handling Equipment.....                 | 13 |
| A2-2b       | Geologic Repository Process Description .....              | 14 |
| A2-3        | Waste Characterization .....                               | 16 |
| A2-4        | Treatment Effectiveness.....                               | 16 |
| A2-5        | Maintenance, Monitoring, and Inspection .....              | 17 |
| A2-5a       | Maintenance .....  | 17 |
| A2-5a(1)    | Ground-Control Program .....                               | 17 |
| A2-5b       | Monitoring.....  | 17 |
| A2-5b(1)    | Groundwater Monitoring .....                               | 17 |
| A2-5b(2)    | Geomechanical Monitoring .....                             | 17 |
| A2-5b(2)(a) | Description of the Geomechanical Monitoring<br>System..... | 17 |
| A2-5b(2)(b) | System Experience .....                                    | 18 |
| A2-5b(3)    | Volatile Organic Compound Monitoring.....                  | 19 |
| A2-5c       | Inspection .....   | 19 |
| References  | .....  | 19 |

## LIST OF TABLES

| Table      | Title  |
|------------|--|
| Table A2-1 | CH TRU Mixed Waste Handling Equipment Capacities                       |
| Table A2-2 | Instrumentation Used in Support of the Geomechanical Monitoring System |
| Table A2-3 | RH TRU Mixed Waste Handling Equipment Capacities                       |

## LIST OF FIGURES

| Figure           | Title   |
|------------------|---|
| Figure A2-1      | Repository Horizon  |
| Figure A2-2      | Spatial View of the Miscellaneous Unit and Waste Handling Facility                                |
| Figure A2-2-S#5  | Spatial View of the Miscellaneous Unit and Waste Handling Facility (with S#5)                     |
| Figure A2-3      | Facility Pallet for Seven-Pack of Drums   |
| Figure A2-5      | Typical Backfill Sacks Emplaced on Drum Stacks  |
| Figure A2-5a     | Potential MgO Emplacement Configurations  |
| Figure A2-6      | Waste Transfer Cage to Transporter  |
| Figure A2-7      | Push-Pull Attachment to Forklift to Allow Handling of Waste Containers                            |
| Figure A2-8      | Typical RH and CH Transuranic Mixed Waste Container Disposal Configuration                        |
| Figure A2-9a     | Underground Ventilation System Airflow  |
| Figure A2-9a-NFB | Underground Ventilation System Airflow (with Building 416)  |
| Figure A2-9b     | Underground Ventilation System Airflow (with SVS)   |
| Figure A2-9c     | Underground Ventilation System Airflow (with S#5)   |
| Figure A2-11     | Typical Room Barricade  |
| Figure A2-11a    | Typical Bulkhead  |
| Figure A2-12     | WIPP Facility Surface and Underground CH Transuranic Mixed Waste Process Flow Diagram             |
| Figure A2-12     | WIPP Facility Surface and Underground CH Transuranic Mixed Waste Process Flow Diagram (Continued) |
| Figure A2-13     | Layout and Instrumentation - As of 1/96   |
| Figure A2-14     | Facility Cask Transfer Car (Side View)  |
| Figure A2-15     | Typical Horizontal Emplacement Equipment  |
| Figure A2-15a    | Typical Horizontal Emplacement Equipment  |
| Figure A2-16     | RH TRU Waste Facility Cask Unloading from Waste Shaft Conveyance                                  |
| Figure A2-17     | Facility Cask Installed on the Typical Emplacement Equipment                                      |
| Figure A2-18     | Installing Shield Plug  |
| Figure A2-19     | Shield Plug Supplemental Shielding Plate(s)   |
| Figure A2-20     | Shielding Layers to Supplement RH Borehole Shield Plugs   |
| Figure A2-21     | Shield Plug Configuration   |

1 **ATTACHMENT A2**

2 **GEOLOGIC REPOSITORY**

3 A2-1 Description of the Geologic Repository

4 Management, storage, and disposal of transuranic (**TRU**) mixed waste in the Waste Isolation  
5 Pilot Plant (**WIPP**) geologic repository is subject to regulation under 20.4.1.500 NMAC. The  
6 WIPP is a geologic repository mined within a bedded salt formation, which is defined in  
7 20.4.1.101 NMAC (incorporating 40 CFR §260.10) as a miscellaneous unit. As such, HWMUs  
8 within the repository are eligible for permitting according to 20.4.1.101 NMAC (incorporating 40  
9 CFR §260.10), and are regulated under 20.4.1.500 NMAC, Miscellaneous Units.

10 As required by 20.4.1.500 NMAC (incorporating 40 CFR §264.601), the Permittees shall ensure  
11 that the environmental performance standards for a miscellaneous unit, which are applied to the  
12 Underground Hazardous Waste Disposal Units (**HWDUs**) in the geologic repository, will be met.

13 The Disposal Phase will consist of receiving contact-handled (**CH**) and remote-handled (**RH**)  
14 TRU mixed waste shipping containers, unloading and transporting the waste containers to the  
15 Underground HWDUs, emplacing the waste in the Underground HWDUs, and subsequently  
16 achieving closure of the Underground HWDUs in compliance with applicable State and Federal  
17 regulations.

18 The WIPP geologic repository is mined within a 2,000-feet (ft) (610-meters (m))-thick bedded-  
19 salt formation called the Salado Formation. The Underground HWDUs (miscellaneous units) are  
20 located 2,150 ft (655 m) beneath the ground surface. TRU mixed waste management activities  
21 underground will be confined to the southern portion of the 120-acre (48.6 hectares) mined area  
22 during the Disposal Phase. During the term of this Permit, disposal of TRU mixed waste will  
23 occur only in the HWDUs designated as Panels 5 through 8 and in any currently active panel  
24 (See Figure A2-1). RH TRU mixed waste disposal began in Panel 4. The Permittees may also  
25 request in the future a Permit to allow disposal of containers of TRU mixed waste in the areas  
26 designated as Panels 9 and 10 in Figure A2-1. This Permit, during its 10-year term, authorizes  
27 the excavation of Panels 6 through 10 and the disposal of waste in Panels 1 through 8.

28 Panels 1 through 8 will consist of seven rooms and two access drifts each. Panels 9 and 10  
29 have yet to be designed. Access drifts connect the rooms and have the same cross section (see  
30 Section A2-2a(3)). The closure system installed in each HWDU after it is filled will prevent  
31 anyone from entering the HWDU and will restrict ventilation airflow. The point of compliance for  
32 air emissions from the Underground is defined in Permit Attachment N (Volatile Organic  
33 Compound Monitoring Plan). The point of compliance is the location where the concentration of  
34 volatile organic compounds (VOCs) in the air emissions from the Underground HWDUs will be  
35 measured and then compared to the VOC action levels ( $10^{-5}$  for carcinogens and  $HI > 1$  for non-  
36 carcinogens) as required by Permit Part 4, Section 4.6.2.3.

37 Description of Four-Shaft Configuration

38 Four shafts connect the underground area with the surface. The Waste Shaft Conveyance  
39 headframe and hoist are located within the Waste Handling Building (**WHB**) and will be used to  
40 transport containers of TRU mixed waste, equipment, and materials to the repository horizon.  
41 The waste hoist can also be used to transport personnel. The Air Intake Shaft and the Salt

1 Handling Shaft provide ventilation to all areas of the mine except for the Waste Shaft Station.  
2 This area is ventilated by the Waste Shaft itself. The Salt Handling Shaft is also used to hoist  
3 mined salt to the surface and serves as the principal personnel transport shaft. The Exhaust  
4 Shaft serves as a common exhaust air duct (air pathway) for all areas of the mine. In some  
5 cases (such as during mining activities), the Salt Handling Shaft will be used as an unfiltered  
6 exhaust shaft. The Salt Shaft exhaust air will come from the North or Construction Circuits (i.e.,  
7 areas of the underground that are not contaminated and do not need High-Efficiency Particulate  
8 Air (**HEPA**) filtration). The relationship between the WIPP surface facility, the four shafts, and  
9 the geologic repository horizon is shown on Figure A2-2.

#### 10 Description of Five-Shaft Configuration (with Shaft #5)

11 A fifth shaft, Shaft #5 (**S#5**), also connects the underground facility with the surface. The  
12 relationship between the WIPP surface facility, the five shafts, and the underground facility  
13 horizon is shown in Figure A2-2-S#5. With S#5 in use, the configuration of the shafts is as  
14 follows:

- 15 • Shaft #5 provides the majority of the intake air for the underground facility.
- 16 • The Air Intake Shaft provides the exhaust air pathway for the construction area of the  
17 underground facility.
- 18
- 19 • The Waste Shaft Conveyance headframe and hoist are located within the WHB and are  
20 used to transport containers of TRU mixed waste, equipment, and materials to the  
21 repository horizon. The waste hoist can also be used to transport personnel.
- 22
- 23 • The Waste Shaft provides intake air for the Waste Shaft Station.
- 24
- 25 • The Salt Handling Shaft provides a portion of the ventilation for the north area of the  
26 underground facility and is also used to hoist mined salt to the surface and serve as the  
27 principle personnel transport shaft.
- 28
- 29 • The Exhaust Shaft serves as a common exhaust air pathway for the north, disposal, and  
30 Waste Shaft Station areas of the underground facility.

31 The HWDUs identified as Panels 1 through 8 (Figure A2-1) provide room for up to 5,244,900  
32 cubic feet (ft<sup>3</sup>) (148,500 cubic meters (m<sup>3</sup>)) of CH TRU mixed waste. The CH TRU mixed waste  
33 containers may be stacked up to three high across the width of the room.

34 Panels 4 through 8 provide room for up to 93,050 ft<sup>3</sup> (2,635 m<sup>3</sup>) of RH TRU mixed waste. RH  
35 TRU mixed waste may be disposed of in up to 730 boreholes per panel, subject to the  
36 limitations in Permit Part 4, Section 4.1.1.2.ii. These boreholes shall be drilled on nominal eight-  
37 foot centers, horizontally, about mid-height in the ribs of a disposal room. The thermal loading  
38 from RH TRU mixed waste shall not exceed 10 kilowatts per acre when averaged over the area  
39 of a panel, as shown in Permit Attachment A3, plus 100 feet of each of a Panel's adjoining  
40 barrier pillars.

41 The WIPP facility is located in a sparsely populated area with site conditions favorable to  
42 isolation of TRU mixed waste from the biosphere. Geologic and hydrologic characteristics of the

1 site related to its TRU mixed waste isolation capabilities are discussed in Addendum L1 of the  
2 WIPP Hazardous Waste Facility Permit Amended Renewal Application (DOE, 2009). Hazard  
3 prevention programs are described in this Permit Attachment. Contingency and emergency  
4 response actions to minimize impacts of unanticipated events, such as spills, are described in  
5 Permit Attachment D. The closure plan for the WIPP facility is described in Permit Attachment  
6 G.

## 7 A2-2 Geologic Repository Design and Process Description

### 8 A2-2a Geologic Repository Design and Construction

9 The WIPP facility, when operated in compliance with the Permit, will ensure safe operations and  
10 be protective of human health and the environment.

11 As a part of the design validation process, geomechanical tests were conducted in SPDV test  
12 rooms. During the tests, salt creep rates were measured. Separation of bedding planes and  
13 fracturing were also observed. Consequently, a ground-control strategy was implemented. The  
14 ground-control program at the WIPP facility mitigates the potential for roof or rib falls and  
15 maintains normal excavation dimensions, as long as access to the excavation is possible.

#### 16 A2-2a(1) CH TRU Mixed Waste Handling Equipment

17 The following are the major pieces of equipment used to manage CH TRU waste in the geologic  
18 repository. A summary of equipment capacities, as required by 20.4.1.500 NMAC is included in  
19 Table A2-1.

#### 20 Facility Pallets

21 The facility pallet is a fabricated steel unit designed to support 7-packs, 3-packs, or 4-packs of  
22 drums, standard waste boxes (**SWBs**), ten-drum overpacks (**TDOPs**), or a standard large box 2  
23 (**SLB2**), and has a rated load of 25,000 pounds (lbs.) (11,430 kilograms (kg)). The facility pallet  
24 will accommodate up to four 7-packs, four 3-packs, two 3-packs of shielded containers, four 4-  
25 packs of drums, four SWBs (in two stacks of two units), two TDOPs, or one SLB2. Loads are  
26 secured to the facility pallet during transport to the emplacement area. Facility pallets are shown  
27 in Figure A2-3. Fork pockets in the side of the pallet allow the facility pallet to be lifted and  
28 transferred by forklift to prevent direct contact between TRU mixed waste containers and forklift  
29 tines. This arrangement reduces the potential for puncture accidents. WIPP facility operational  
30 documents define the operational load of the facility pallet to ensure that the rated load of a  
31 facility pallet is not exceeded.

#### 32 Backfill

33 Magnesium oxide (**MgO**) will be used as a backfill in order to provide chemical control over the  
34 solubility of radionuclides in order to comply with the requirements of 40 CFR §191.13. The  
35 MgO backfill will be purchased prepackaged in the proper containers for emplacement in the  
36 underground. Purchasing prepackaged backfill eliminates handling and placement problems  
37 associated with bulk materials, such as dust creation. In addition, prepackaged materials will be  
38 easier to emplace, thus reducing potential worker exposure to radiation. Should a backfill  
39 container be breached, MgO is benign and cleanup is simple. No hazardous waste would result  
40 from a spill of backfill.

1 The MgO backfill will be managed in accordance with Specification D-0101 (MgO Backfill  
2 Specification) and WP05-WH1025 (CH Waste Downloading and Emplacement). These  
3 documents are kept on file at the WIPP facility by the Permittees.

4 Backfill will be handled in accordance with standard operating procedures. Typical emplacement  
5 configurations are shown in Figures A2-5 and A2-5a. Some emplacement configurations may  
6 include the use of MgO emplacement racks, as shown in Figure A2-5a.

7 Quality control will be provided within standard operating procedures to record that the correct  
8 number of sacks are placed and that the condition of the sacks is acceptable.

9 Backfill placed in this manner is protected until exposed when sacks are broken during creep  
10 closure of the room and compaction of the backfill and waste. Backfill in sacks utilizes existing  
11 techniques and equipment and eliminates operational problems such as dust creation and  
12 introducing additional equipment and operations into waste handling areas. There are no mine  
13 operational considerations (e.g. ventilation flow and control) when backfill is placed in this  
14 manner.

#### 15 The Waste Shaft Conveyance

16 The hoist systems in the shafts and all shaft furnishings are designed to resist the dynamic  
17 forces of the hoisting system and to withstand a design-basis earthquake of 0.1 g. Appendix D2  
18 of the WIPP RCRA Part B Permit Application (DOE, 1997) provided engineering design-basis  
19 earthquake report which provides the basis for seismic design of WIPP facility structures. The  
20 waste hoist is equipped with a control system that will detect malfunctions or abnormal  
21 operations of the hoist system (such as overtravel, overspeed, power loss, circuitry failure, or  
22 starting in a wrong direction) and will trigger an alarm that automatically shuts down the hoist.

23 The waste hoist moves the Waste Shaft Conveyance and is a multirope, friction-type hoist. A  
24 counterweight is used to balance the waste shaft conveyance. The waste shaft conveyance  
25 (outside dimensions) is 30 ft (9 m) high by 10 ft (3 m) wide by 15 ft (4.5 m) deep and can carry a  
26 payload of 45 tons (40,824 kg). During loading and unloading operations, it is steadied by fixed  
27 guides. The hoist's maximum rope speed is 500 ft (152.4 m) per min.

28 The Waste Shaft hoist system has two sets of brakes, with two units per set, plus a motor that is  
29 normally used to stop the hoist. The brakes are designed so that either set, acting alone, can  
30 stop a fully loaded conveyance under all emergency conditions.

#### 31 The Underground Waste Transporter

32 The underground waste transporter is a commercially available diesel-powered tractor. The  
33 trailer was designed specifically for the WIPP for transporting facility pallets from the waste shaft  
34 conveyance to the Underground HWDU in use. This transporter is shown in Figure A2-6.

#### 35 Underground Forklifts

36 CH TRU mixed waste containers loaded on slipsheets will be removed from the facility pallets  
37 using forklifts with a push-pull attachment (Figure A2-7) attached to the forklift-truck front  
38 carriage. The push-pull attachment grips the edge of the slipsheet (on which the waste  
39 containers sit) to pull the containers onto the platen. After the forklift moves the waste



1 containers to the emplacement location, the push-pull attachment pushes the containers into  
2 position. The use of the push-pull attachment prevents direct contact between waste containers  
3 and forklift tines. SWBs and TDOPs may also be removed from the facility pallet by using  
4 forklifts equipped with special adapters for these containers. These special adapters will prevent  
5 direct contact between SWBs or TDOPs and forklift tines. In addition, the low clearance forklift  
6 that is used to emplace MgO may be used to emplace waste if necessary.

7 A forklift will be used to offload the SLB2 from the underground transporter and emplace the  
8 waste container in the waste stack.

#### 9 A2-2a(2) Shafts

#### 10 Four-Shaft Configuration

11 The WIPP facility uses four shafts: the Waste Shaft, the Salt Handling Shaft, the Air Intake  
12 Shaft, and the Exhaust Shaft. These shafts are vertical openings that extend from the surface to  
13 the repository level.

14 The Waste Shaft is located beneath the WHB and is 19 to 20 ft (5.8 to 6.1 m) in diameter. The  
15 Salt Handling Shaft, located north of the Waste Shaft beneath the salt handling headframe, is  
16 10 to 12 ft (3 to 3.6 m) in diameter. Salt mined from the repository horizon is removed through  
17 the Salt Handling Shaft. The Salt Handling Shaft is the main personnel and materials hoist and  
18 also serves as a secondary supply air pathway for the underground areas. The Air Intake Shaft,  
19 northwest of the WHB, varies in diameter from 16 ft 7 in. (4.51 m) to 20 ft 3 in. (6.19 m) and is  
20 the primary source of fresh air underground. The Exhaust Shaft, east of the WHB, is 14 to 15 ft  
21 (4.3 to 4.6 m) in diameter and serves as the exhaust air pathway for the underground air. In  
22 some cases, the Salt Handling Shaft may be used as an unfiltered exhaust shaft to ventilate  
23 areas of the underground that do not need filtration.

#### 24 Five-Shaft Configuration (with S#5)

25 A fifth shaft, S#5, also extends from the surface to the repository level. The inside diameter of  
26 S#5 is approximately 26 ft (8 m). With S#5 in use, it is the primary source of fresh air to the  
27 underground facility. With S#5 in use, the ventilation functions of the existing shafts are as  
28 follows:

- 29 • Salt Handling Shaft serves as a secondary supply-air (intake air) pathway for the  
30 underground facility.
- 31
- 32 • The Waste Shaft serves as the supply-air (intake air) pathway for the Waste Shaft  
33 Station.
- 34
- 35
- 36 • The Air Intake Shaft serves as the exhaust air pathway for the construction area of the  
37 underground facility.
- 38
- 39 • The Exhaust Shaft serves as the exhaust air pathway for the north, disposal and Waste  
40 Shaft Station areas of the underground facility.

## 1 General Shaft Description

2 Openings excavated in salt experience closure because of salt creep (or time-dependent  
3 deformation at constant load). The closure affects the design of all of the openings discussed in  
4 this section. Underground excavation dimensions, therefore, are nominal, because they change  
5 with time. The unlined portions of the shafts have larger diameters than the lined portions, which  
6 allows for closure caused by salt creep. Each shaft includes a shaft collar, a shaft lining, and a  
7 shaft key section. The Final Design Validation Report in Appendix D1 of the WIPP RCRA Part B  
8 Permit Application (DOE, 1997) discusses the original four shafts and shaft components in  
9 greater detail.

10 The reinforced-concrete shaft collars extend from the surface to the top of the underlying  
11 consolidated sediments. Each collar serves to retain adjacent unconsolidated sands and soils  
12 and to prevent surface runoff from entering the shafts. The shaft linings extend from the base of  
13 the collar to the top of the salt beds approximately 850 ft (259 m) below the surface. Grout  
14 injected behind the shaft lining or a polymeric spray coating retards water seeping into the  
15 shafts from water-bearing formations, and the liner is designed to withstand the natural water  
16 pressure associated with these formations. The shaft liners are concrete, except in the Salt  
17 Handling Shaft, where a steel shaft liner has been grouted in place.

18 The shaft key is a circular reinforced concrete section emplaced in each shaft below the liner in  
19 the base of the Rustler and extending about 50 ft (15 m) into the Salado. The key functions to  
20 resist lateral pressures and assures that the liner will not separate from the host rocks or fail  
21 under tension. This design feature also aids in preventing the shaft from becoming a route for  
22 groundwater flow into the underground facility.

23 On the inside surface of each shaft, excluding the Salt Handling Shaft and S#5, there are three  
24 water- collection rings: one just below the Magenta, one just below the Culebra, and one at the  
25 lowermost part of the key section. These collection rings will collect water that may seep into the  
26 shaft through the liner. The Salt Handling Shaft has a single water collection ring in the lower  
27 part of the key section. Water collection rings are drained by tubes to the base of the shafts  
28 where the water is accumulated. Shaft #5 is outfitted with water stops at each shaft liner cold  
29 joint throughout the lined portion of the shaft.

30 WIPP shafts and other underground facilities are, for all practical purposes, dry. Minor quantities  
31 of water (which accumulate in some shaft sumps) are insufficient to affect the waste disposal  
32 area. This water is collected, brought to the surface, and disposed of in accordance with current  
33 standards and regulations.

34 The Waste Shaft is protected from precipitation by the roof of the waste shaft conveyance  
35 headframe tower. The Exhaust Shaft is configured at the top with a 14 ft- (4.3 m-) diameter duct  
36 that diverts air into the exhaust filtration system or to the atmosphere, as appropriate. The Salt  
37 Handling and Air Intake Shaft collars are open except for the headframes. Rainfall into the  
38 shafts is evaporated by ventilation air. Shaft #5 is covered to direct intake air into the  
39 underground facility using fans located on the surface. The fans are connected to the shaft via  
40 ducting and a plenum.

41 With S#5 in use, the Air Intake Shaft is converted to an exhaust shaft for Construction Circuit air  
42 by routing the air through a plenum and ducting to an unfiltered exhaust stack.

1 The waste hoist system in the Waste Shaft and all Waste Shaft furnishings are designed to  
2 resist the dynamic forces of the hoisting system, which are greater than the seismic forces on  
3 the underground facilities. In addition the Waste Shaft conveyance headframe is designed to  
4 withstand the design-basis earthquake (**DBE**). Maximum operating speed of the hoist is 500 ft  
5 (152.4 m) per minute. During loading and unloading operations, the waste hoist is steadied by  
6 fixed guides. The waste hoist is equipped with a control system that will detect malfunctions or  
7 abnormal operations of the hoist system, such as overtravel, overspeed, power loss, or circuitry  
8 failure. The control response is to annunciate the condition and shut the hoist down. Operator  
9 response is required to recover from the automatic shutdown. Waste hoist operation is  
10 continuously monitored by the CMS. A battery powered FM transmitter/receiver allows  
11 communication between the hoist conveyance and the hoist house.

12 The waste hoist has two pairs of brake calipers acting on independent brake paths. The hoist  
13 motor is normally used for braking action of the hoist. The brakes are used to hold the hoist in  
14 position during normal operations and to stop the hoist under emergency conditions. Each pair  
15 of brake calipers is capable of holding the hoist in position during normal operating conditions  
16 and stopping the hoist under emergency conditions. In the event of power failure, the brakes will  
17 set automatically.

18 The waste hoist is protected by a fixed automatic fire suppression system. Portable fire  
19 extinguishers are also provided on the hoist floor and in equipment areas.

## 20 A2-2a(3) Subsurface Structures

21 The subsurface structures in the repository, located at 2,150 ft (655 m) below the surface,  
22 include the HWDUs, the northern experimental areas, and the support areas. Appendix D3 of  
23 the WIPP RCRA Part B Permit Application (DOE, 1997) provided details of the underground  
24 layout. Figure A2-8 shows the proposed waste emplacement configuration for the HWDUs.

25 The status of important underground equipment, including fixed fire-protection systems, the  
26 ventilation system, and contamination detection systems, will be monitored by a central  
27 monitoring system, located in the Support Building adjacent to the WHB. Backup power will be  
28 provided as discussed below. The subsurface support areas are constructed and maintained to  
29 conform to Federal mine safety codes.

## 30 Underground Hazardous Waste Disposal Units (HWDUs)

31 During the terms of this and the preceding Permit, the TRU mixed waste volume emplaced in  
32 the repository will not exceed the maximum capacities listed in Permit Part 4, Table 4.1.1 for  
33 each HWDU. CH TRU mixed waste will be disposed of in Underground HWDUs identified as  
34 Panels 1 through 8. RH TRU mixed waste may be disposed of in Panels 4 through 8.

35 Main entries and cross cuts in the repository provide access and ventilation to the HWDUs. The  
36 main entries link the shaft pillar/service area with the TRU mixed waste management area and  
37 are separated by pillars. Each of the Underground HWDUs labeled Panels 1 through 8 will have  
38 seven rooms. The locations of these HWDUs are shown in Figure A2-1. The rooms in Panels 1-  
39 7 will have nominal dimensions of 13 ft (4.0 m) high by 33 ft (10 m) wide by 300 ft (91 m) long  
40 and will be supported by 100 ft- (30 m-) wide pillars. The rooms in Panel 8 will have nominal  
41 dimensions of 16 ft (5.0 m) high by 33 ft (10 m) wide by 300 ft (91 m) long and will be supported  
42 by 100 ft (30 m) wide pillars.

1 As currently planned, future Permits may allow disposal of TRU mixed waste containers in two  
2 additional panels, identified as Panels 9 and 10. Disposal of TRU mixed waste in Panels 9 and  
3 10 is prohibited under this Permit. If TRU mixed waste volumes disposed of in the eight panels  
4 fail to reach the stated design capacity, the Permittees may request a Permit to allow disposal of  
5 TRU mixed waste in the four main entries and crosscuts adjacent to the waste panels (referred  
6 to as the disposal area access drifts). These areas are labeled Panels 9 and 10 in Figure A2-1.  
7 A permit modification or future permit would be submitted describing the condition of those drifts  
8 and the controls exercised for personnel safety and environmental protection while disposing of  
9 waste in these areas. These areas have the following nominal dimensions:

- 10 • The E-140 waste transport route south of the Waste Shaft Station is mined to be  
11 25 ft wide nominally and its height ranges from about 14 ft to 20 ft.
- 12 • The W-30 waste transport route south of S-700 is mined to be 20 ft wide nominally  
13 and its height will be mined to at least 14 ft.
- 14 • All other drifts that are part of the waste transport route will be at least 20 ft wide  
15 and 14 ft high to accommodate waste transport equipment.
- 16 • Other drifts (i.e. mains and cross-cuts) vary in width and height according to their  
17 function typically ranging from 14 ft to 20 ft wide and 12 ft to 20 ft high.

18 The layout of these excavations is shown on Figure A2-1.

#### 19 Underground Facilities Ventilation System

20 The underground facilities ventilation system will provide a safe and suitable environment for  
21 underground operations during normal WIPP facility operations. The underground system is  
22 designed to provide control of potential airborne contaminants in the event of an accidental  
23 release or an underground fire.

24 The underground is divided into specific areas that are supported by different ventilation flows  
25 referred to as ventilation circuits. Consequently, the underground ventilation system is  
26 comprised of four separate circuits, as designated on Figure A2-9a: one serving the northern  
27 experimental areas (North Circuit), one serving the construction areas (Construction Circuit),  
28 one serving the waste disposal areas (Disposal Circuit), and one serving the waste shaft station  
29 area (Waste Shaft Station Circuit). The four circuits are recombined near the bottom of the  
30 Exhaust Shaft, which serves as a common exhaust route from the underground level to the  
31 surface. In some cases, the Salt Handling Shaft may be used as an unfiltered exhaust shaft  
32 (Figure A2-9b) to ventilate areas of the underground that do not need filtration.

33 With S#5 in use (Figure A2-9c), the Salt Handling Shaft serves as the secondary supply-air  
34 pathway for the underground facility while S#5 serves as the primary supply-air pathway for the  
35 underground facility. The Waste Shaft supplies the intake air for the Waste Shaft Station. The  
36 Air Intake Shaft provides the exhaust route for the Construction Circuit while the Exhaust Shaft  
37 provides the exhaust route for the North, Disposal, and Waste Shaft Station Circuits.

1 Underground Ventilation System Description

2 The underground ventilation system consists of centrifugal exhaust fans, two identical HEPA-  
3 filter assemblies arranged in parallel, isolation dampers, a filter bypass arrangement, two skid-  
4 mounted HEPA-filter assemblies arranged in parallel, and associated ductwork. The fans,  
5 connected by the ductwork to the underground exhaust shaft so that they can independently  
6 draw air through the Exhaust Shaft, are divided into three groups. One group consists of three  
7 main exhaust fans, two of which are utilized to provide the nominal air flow of 425,000 standard  
8 ft<sup>3</sup> per minute (**scfm**) throughout the WIPP facility underground during normal (unfiltered)  
9 operation. One main fan may be operated in the alternate mode to provide 260,000 scfm  
10 underground ventilation flow. These fans are located near the Exhaust Shaft. The second group  
11 consists of three filtration fans, and each can provide 60,000 scfm of air flow. These fans,  
12 located at the Exhaust Filter Building, can be operated in the filtration mode, where exhaust is  
13 diverted through HEPA filters, or in the reduced or minimum ventilation mode, where air is not  
14 drawn through the HEPA filters. The third group consists of two skid-mounted filtration fans and  
15 HEPA-filter assemblies, each of which can provide approximately 23,000 scfm of air flow. The  
16 skid-mounted filtration fan and HEPA-filter assemblies, referred to as the Interim Ventilation  
17 System (**IVS**) located south of the Exhaust Filter Building, are only operated in filtration mode,  
18 where exhaust is diverted through HEPA filters. In addition to the surface fans, an underground  
19 fan has been installed to ventilate uncontaminated areas in the North and Construction Circuits.  
20 This system is referred to as the Supplemental Ventilation System (**SVS**) and will be used in  
21 conjunction with IVS (as shown in Figure A2-9b). When this fan is operating, the Salt Shaft will  
22 serve as an unfiltered exhaust shaft for the North and Construction Circuits. A portion of the  
23 airflow provided by the SVS to the Construction Circuit can also be used to provide fresh air to  
24 the Disposal Circuit, if needed. In this case, the air from the Disposal Circuit will continue to be  
25 exhausted through the HEPA filtration system.

26 When the repository is configured to use five shafts, two fans located on the surface and  
27 connected via ducting and a plenum to S#5, supply the majority of the intake air to the  
28 underground facility. One fan operates at a time, while the idle fan is available as a back-up fan.  
29 The Salt Handling Shaft serves as a secondary air intake shaft for the north area and the Waste  
30 Shaft serves as the air intake shaft for the Waste Shaft Station area of the underground facility.  
31 The Air Intake Shaft serves as an unfiltered exhaust shaft for the construction area of the  
32 underground facility. The north, disposal, and Waste Shaft Station areas of the underground  
33 facility are exhausted through the Exhaust Shaft and the associated filtration system.

34 The underground mine ventilation is designed to supply sufficient quantities of air to all areas of  
35 the repository. During normal operating mode (simultaneous mining and waste emplacement  
36 operations), approximately 140,000 actual ft<sup>3</sup> (3,962 m<sup>3</sup>) per min can be supplied to the panel  
37 area. This quantity is necessary in order to support the level of activity and the pieces of diesel  
38 equipment that are expected to be in operation.

39 At any given time during waste emplacement activities, there may be significant activities in  
40 multiple rooms in a panel. For example, one room may be receiving CH TRU mixed waste  
41 containers, another room may be receiving RH TRU mixed waste canisters, and the drilling of  
42 RH TRU mixed waste emplacement boreholes may be occurring in another room. The  
43 remaining rooms in a panel will either be completely filled with waste; be idle, awaiting waste  
44 handling operations; or being prepared for waste receipt. A minimum ventilation rate of 35,000  
45 standard ft<sup>3</sup> (990 standard m<sup>3</sup>) per minute will be maintained in each active room when waste  
46 disposal is taking place and workers are present in the room. This quantity of air is required to

1 support the numbers and types of diesel equipment that are expected to be in operation in the  
2 area, and to support the underground personnel working in that area. The remainder of the air is  
3 needed in order to account for air leakage through inactive rooms. If an active room ventilation  
4 rate of 35,000 scfm cannot be met, actions as described in Permit Attachment O shall be taken  
5 during waste disposal operations when workers are present.

6 Air will be routed into a panel from the intake side. Air is routed through the individual rooms  
7 within a panel using any of the following flow control devices: underground bulkheads, brattice  
8 cloth barricades, bulkheads with doors or air regulators. Bulkheads are constructed by erecting  
9 framing of rectangular steel tubing and screwing galvanized sheet metal to the framing.  
10 Bulkhead members use telescoping extensions that are attached to framing and the salt which  
11 adjust to creep. Flexible flashing attached to the bulkhead on one side and the salt on the other  
12 completes the seal of the ventilation. Where controlled airflow is required, a louver-style damper  
13 or a slide-gate (sliding panel) regulator is installed on the bulkhead. Personnel access is  
14 available through most bulkheads, and vehicular access is possible through selected bulkheads.  
15 Vehicle roll-up doors in the panel areas are not equipped with warning bells or strobe lights  
16 since these doors are to be used for limited periodic maintenance activities in the return air path.  
17 Flow is also controlled using brattice cloth barricades. These consist of chain link fence that is  
18 bolted to the salt or attached to a structural member and covered with brattice cloth; and are  
19 used in instances where the only flow control requirement is to block the air. A brattice cloth air  
20 barricade is shown in Figure A2-11. Ventilation will be maintained only in all active rooms within  
21 a panel until waste emplacement activities are completed and the panel-closure system is  
22 installed. The air will be routed simultaneously through all the active rooms within the panel. The  
23 filled rooms will be isolated from the ventilation system, while the active rooms that are actively  
24 being filled will receive a minimum of 35,000 scfm of air when workers are present to assure  
25 worker safety. If an active room ventilation rate of 35,000 scfm cannot be met, actions as  
26 described in Permit Attachment O shall be taken during waste disposal operations when  
27 workers are present. After all rooms within a panel are filled, the panel will be closed using a  
28 closure system described Permit Attachment G and Permit Attachment G1.

29 Once a disposal room is filled and is no longer needed for emplacement activities, it will be  
30 barricaded against entry and isolated from the mine ventilation system. This may be  
31 accomplished by any of the following: by removing the air regulator bulkhead, closing bulkhead  
32 doors, constructing chain link/brattice cloth barricades and, if necessary, constructing bulkheads  
33 at each end. A typical bulkhead is shown in Figure A2-11a. There is no requirement for air for  
34 these rooms since personnel and/or equipment will not be in these areas.

35 The ventilation path for the waste disposal side is separated from the construction (e.g., mining)  
36 side by means of air locks, bulkheads, and salt pillars. A pressure differential is maintained  
37 between the construction side and the waste disposal side to ensure that any leakage is  
38 towards the disposal side. The pressure differential is produced by the surface fans in  
39 conjunction with the underground air regulators.

#### 40 Underground Ventilation Filtration System Description with Buildings 416 and 417

41 The Underground Ventilation Filtration System (**UVFS**) fans which are part of the New Filter  
42 Building (**NFB**) (Building 416) provide enhanced ventilation in the underground, sufficient to  
43 allow concurrent mining and waste emplacement while in filtration mode. The UVFS will provide  
44 filtered airflow through a surface mounted ventilation and filtration system. The intake duct to the  
45 surface ventilation and filtration facility is connected to the Exhaust Shaft. The exhaust from the

1 underground will be directed to the salt reduction system located in the Salt Reduction Building  
2 (**SRB**) (Building 417).

3 Prior to passing through the NFB, air from the Exhaust Shaft may be directed through the SRB,  
4 which contains de-dusters, commonly used in the mining industry, and de-misters for salt dust  
5 and brine/water mist removal. The salt reduction system consists of multiple parallel de-dusting  
6 units. The exhaust from the de-dusting units is directed to the filter supply manifold and then to  
7 the filtration units. The de-duster and de-mister combination has a water wash down system that  
8 is connected to a water collection, treatment and sludge tank. The outlet of the water collection,  
9 treatment, and sludge tank is piped out of the SRB to an evaporative pond. Accumulated water  
10 and salt will be characterized and disposed of in accordance with WIPP facility standard  
11 operating procedures.

12 Differential pressure instrumentation will be provided with a high differential pressure alarm,  
13 which is monitored in the CMR. The exhaust from each of the filter banks is directed to a  
14 plenum which has a single duct that discharges to the environment through a stack.

#### 15 Underground Ventilation Modes of Operation

16 When the repository is configured to use four shafts, the underground ventilation system is  
17 designed to perform under three types of operation: normal (the HEPA exhaust filtration system  
18 is bypassed), filtered (the exhaust is filtered through the HEPA filtration system), if radioactive  
19 contaminants are detected or suspected, or a  
20 combined mode in which the air in the Disposal Circuit is filtered and the air in the North and  
21 Construction Circuits is unfiltered.

22 The possible modes of exhaust fan operation are as follows:

- 23 • 2 main fans in operation
- 24 • 1 main fan in operation
- 25 • 1 filtration fan in filtered operation
- 26 • 2 fans in filtered operation (one filtration fan and one IVS fan or two IVS fans)
- 27 • 3 fans in filtered operation (one filtration fan and two IVS fans)
- 28 • 1 filtration fan in unfiltered operation
- 29 • 2 filtration fans in unfiltered operation
- 30 • 1 main and 1 filtration fan in unfiltered operation
- 31 • 3 fans in filtered operation (one filtration fan and two IVS fans exhausting through  
32 the Exhaust Shaft) and an underground SVS fan in operation (boosting fresh air  
33 into the mine causing the Salt Handling Shaft to serve as an unfiltered exhaust  
34 shaft for the North and Construction Circuits)

#### 35 36 Underground Ventilation Filtration System Modes of Operation with Building 416

37  
38 The UVFS, which includes the NFB, is designed to perform under two types of operation:  
39 filtered (the exhaust is filtered through the HEPA filtration system), and bypassed (the HEPA  
40 exhaust filtration system is bypassed).

41  
42 For UVFS Filtration Mode

- 43 • 1 exhaust fan

- 1           • 2 exhaust fans
- 2           • 3 exhaust fans
- 3           • 4 exhaust fans

4  
5 For UVFS Bypass Mode

- 6           • 1 to 4 exhaust fans

7  
8 Under some circumstances (e.g. power outages and maintenance activities), exhaust fan  
9 operation may be discontinued for short periods of time.

10 In the normal mode, two main surface exhaust fans, located near the Exhaust Shaft, will provide  
11 continuous ventilation of the underground areas. In this mode, underground flows join at the  
12 bottom of the Exhaust Shaft before discharge to the atmosphere. However, in some cases, the  
13 Salt Handling Shaft may be used as an unfiltered exhaust shaft to ventilate areas of the  
14 underground that do not need filtration.

15 Typically, outside air will be supplied to the construction areas and the waste disposal areas  
16 through the Air Intake Shaft, the Salt Handling Shaft, and access entries. A small quantity of  
17 outside air will flow down the Waste Shaft to ventilate the Waste Shaft station. The ventilation  
18 system is designed to operate with the Air Intake Shaft as the primary source of fresh air. Under  
19 these circumstances, sufficient air will be available to simultaneously conduct all underground  
20 operations (e.g., waste handling, mining, experimentation, and support). Ventilation may be  
21 supplied by operating fans in the configurations listed in the above description of the ventilation  
22 modes.

23 An underground SVS fan, located in the S-90 drift, provides additional ventilation to the  
24 underground facility, as needed. The SVS ventilates the following:

- 25
- 26       • The North and Construction Circuits, exhausting through the Salt Handling Shaft and
- 27
- 28       • The disposal areas of the underground, exhausting through the Exhaust Shaft and
- 29       through the filtration system

30 When the repository is configured to use five shafts, two intake fans located on the surface and  
31 connected to S#5 via ducting and a plenum, supply the majority of the intake air to the  
32 underground facility. The fans are designed to operate one fan at a time with the second fan  
33 available as a back-up fan. The fans have variable frequency drives that can adjust the intake  
34 flow at S#5 to meet the requirements of the underground ventilation filtration system and the  
35 Construction Circuit.

36 If the nominal flow of 425,000 scfm (12,028 m<sup>3</sup>/min) is not available (e.g., only one of the main  
37 ventilation fans is available) underground operations may proceed, the number of activities that  
38 can be performed in parallel may be limited. depending on the quantity of air available.  
39 Ventilation may be supplied by operating one or more of the filtration exhaust fans. To  
40 accomplish this, the isolation dampers will be opened, which will permit air to flow from the main  
41 exhaust duct to the filter outlet plenum or to the IVS. The filtration fans may also be operated to  
42 bypass the HEPA plenum. The isolation dampers of the filtration exhaust fan(s) to be employed  
43 will be opened, and the selected fan(s) will be switched on. In this mode, underground



1 operations will be limited, because filtration exhaust fans cannot provide sufficient airflow to  
2 support the use of diesel equipment.

3 If the nominal flow of 425,000 scfm (12,028 m<sup>3</sup>/min) is not available because the facility is  
4 operating in filtration mode, the exhaust air will pass through HEPA-filter assemblies, with  
5 filtration fans operating (i.e., all other fans are stopped). This system provides a means for  
6 removing the airborne particulates that may contain radioactive and hazardous waste  
7 particulates before they are discharged through the exhaust stack to the atmosphere. The  
8 filtration mode is activated manually or automatically if the radiation monitoring system detects  
9 abnormally high concentrations of airborne radioactive particulates (an alarm is received from  
10 the continuous air monitor in the exhaust drift of the active waste panel) or a waste handling  
11 incident with the potential for a waste container breach is observed. The filtration mode is not  
12 initiated by the release of gases such as VOCs.

13 If utility power fails, the exhaust filter system is powered by backup diesel generators. Normal  
14 TRU mixed waste handling and related operations cease upon loss of utility power and are not  
15 resumed until normal utility power is returned. As specified in Part 2, all waste handling  
16 equipment will "fail safe," meaning that it will retain its load during a power outage.

#### 17 Underground Ventilation Normal Mode Redundancy

18 The underground ventilation system has been provided redundancy in normal ventilation mode  
19 by the addition of a third main fan. Ductwork leading to that new fan ties into the existing main  
20 exhaust duct.

#### 21 Electrical System

22 The WIPP facility uses electrical power (utility power) supplied by the regional electric utility  
23 company. If there is a loss of utility power, TRU mixed waste handling and related operations  
24 will cease.

25 Backup, alternating current power will be provided on site by diesel generators. These units  
26 provide a high degree of reliability. Each of the diesel generators can carry predetermined  
27 equipment loads while maintaining additional power reserves. Predetermined loads include  
28 lighting and ventilation for underground facilities, lighting and ventilation for the TRU mixed  
29 waste handling areas, and the Air Intake Shaft hoist. The diesel generators can be brought on  
30 line within 30 minutes either manually or from the control panel in the Central Monitoring Room  
31 (**CMR**).

32 Uninterruptible power supply (**UPS**) units are also on line providing power to predetermined  
33 monitoring systems. These systems ensure that the power to the radiation detection system for  
34 airborne contamination, the local processing units, the computer room, and the CMR will always  
35 be available, even during the interval between the loss of off-site power and initiation of backup  
36 diesel generator power.

#### 37 A2-2a(4) RH TRU Mixed Waste Handling Equipment

38 The following are the major pieces of equipment used to manage RH TRU mixed waste in the  
39 geologic repository. A summary of equipment capacities is included in Table A2-3.

## The Facility Cask Transfer Car

The Facility Cask Transfer Car is a self-propelled rail car (Figure A2-14) that operates between the Facility Cask Loading Room and the geologic repository. After the Facility Cask is loaded, the Facility Cask Transfer Car moves onto the waste shaft conveyance and is then transported underground. At the underground waste shaft station, the Facility Cask Transfer Car proceeds away from the waste shaft conveyance to provide forklift access to the Facility Cask.

## Horizontal Emplacement and Retrieval Equipment or Functionally Equivalent Equipment

The Horizontal Emplacement and Retrieval Equipment (**HERE**) or functionally equivalent equipment (Figure A2-15) emplaces canisters into a borehole in a room wall of an Underground HWDU. Once the canisters have been emplaced, the HERE then fills the borehole opening with a shield plug.

## A2-2b Geologic Repository Process Description

Prior to receipt of TRU mixed waste at the WIPP facility, waste operators will be thoroughly trained in the safe use of TRU mixed waste handling and transport equipment. The training will include both classroom training and on-the-job training.

## RH TRU Mixed Waste Emplacement

The Facility Cask Transfer Car is loaded onto the waste shaft conveyance and is lowered to the waste shaft station underground. At the waste shaft station underground, the Facility Cask is moved from the waste shaft conveyance by the Facility Cask Transfer Car (Figure A2-16). A forklift is used to remove the Facility Cask from the Facility Cask Transfer Car and to transport the Facility Cask to the Underground HWDU. There, the Facility Cask is placed on the HERE (Figure A2-17). The HERE is used to emplace the RH TRU mixed waste canister into the borehole. The borehole will be visually inspected for obstructions prior to aligning the HERE and emplacement of the RH TRU mixed waste canister. The Facility Cask is moved forward to mate with the shield collar, and the transfer carriage is advanced to mate with the rear Facility Cask shield valve. The shield valves on the Facility Cask are opened, and the transfer mechanism advances to push the canister into the borehole. After retracting the transfer mechanism into the Facility Cask, the forward shield valve is closed, and the transfer mechanism is further retracted into its housing. The transfer mechanism is moved to the rear, and the shield plug carriage containing a shield plug is placed on the emplacement machine. The transfer mechanism is used to push the shield plug into the Facility Cask. The front shield valve is opened, and the shield plug is pushed into the borehole (Figure A2-18). The transfer mechanism is retracted, the shield valves close on the Facility Cask, and the Facility Cask is removed from the HERE.

A shield plug is a concrete filled cylindrical steel shell (Figure A2-21) approximately 61 in. long and 29 in. in diameter, made of concrete shielding material inside a 0.24 in. thick steel shell with a removable pintle at one end. Each shield plug has integral forklift pockets and weighs approximately 3,750 lbs. The shield plug is inserted with the pintle end closest to the HERE to provide the necessary shielding, limiting the borehole radiation dose rate at 30 cm to less than 10 mrem per hour for a canister surface dose rate of 100 rem/hr. Additional shielding is provided at the direction of the Radiological Control Technician based on dose rate surveys following shield plug emplacement. This additional shielding is provided by the manual

1 emplacement of one or more shield plug supplemental shielding plates and a retainer (Figures  
2 A2-19 and A2-20).

3 The amount of RH TRU mixed waste disposal in each panel is limited based on thermal and  
4 geomechanical considerations and shall not exceed 10 kilowatts per acre as described in Permit  
5 Attachment A2-1. RH TRU mixed waste emplacement boreholes shall be drilled in the ribs of  
6 the panels at a nominal spacing of 8 ft (2.4 m) center-to-center, horizontally.

7 Figures A1-26 and A1-27 are flow diagrams of the RH TRU mixed waste handling process for  
8 the RH-TRU 72-B and CNS 10-160B casks, respectively.

### 9 CH TRU Mixed Waste Emplacement

10 CH TRU mixed waste containers and shielded containers will arrive by tractor-trailer at the  
11 WIPP facility in sealed shipping containers. Prior to unloading the packages from the trailer,  
12 they will undergo security and radiological checks and shipping documentation reviews. The  
13 trailers carrying the shipping containers will be stored temporarily at the Parking Area Container  
14 Storage Unit (Parking Area Unit). A forklift will remove the Contact Handled Packages from the  
15 transport trailers and a forklift or Yard Transfer Vehicle will transport them into the Waste  
16 Handling Building Container Storage Unit for unloading of the waste containers. Each  
17 TRUPACT-II may hold up to two 7-packs, two 4-packs, two 3-packs, two SWBs, or one TDOP.  
18 Each HalfPACT may hold up to seven 55-gal (208 L) drums, one SWB, one three-pack of  
19 shielded containers or four 85-gal (322 L) drums. Each TRUPACT-III will hold one SLB2. An  
20 overhead bridge crane or Facility Transfer Vehicle with transfer table will be used to remove the  
21 waste containers from the Contact Handled Packaging and place them on a facility or  
22 containment pallet. Each facility pallet has two recessed pockets to accommodate two sets of 7-  
23 packs, two sets of 3-packs, two sets of 4-packs, two SWBs stacked two-high, two TDOPs, or  
24 one SLB2. Each stack of waste containers will be secured prior to transport underground (see  
25 Figure A2-3). A forklift or the facility transfer vehicle will transport the loaded facility pallet to the  
26 conveyance loading room adjacent to the Waste Shaft. The facility transfer vehicle will be driven  
27 onto the waste shaft conveyance deck, where the loaded facility pallet will be transferred to the  
28 waste shaft conveyance, and the facility transfer vehicle will be backed off. Containers of CH  
29 TRU mixed waste (55-gal (208 L) drums, SWBs, 85-gal (322 L) drums, 100-gal (379 L) drums,  
30 and TDOPs) or shielded containers can be handled individually, if needed, using the forklift and  
31 lifting attachments (i.e., drum handlers, parrot beaks).

32 The waste shaft conveyance will lower the loaded facility pallet to the underground. At the waste  
33 shaft station, the CH TRU underground transporter will back up to the waste shaft conveyance,  
34 and the facility pallet will be transferred from the waste shaft conveyance onto the transporter  
35 (see Figure A2-6). The transporter will then move the facility pallet to the appropriate  
36 Underground HWDU for emplacement. The underground waste transporter is equipped with a  
37 fire suppression system, rupture-resistant diesel fuel tanks, and reinforced fuel lines to minimize  
38 the potential for a fire involving the fuel system.

39 A forklift in the HWDU near the waste stack will be used to remove the waste containers from  
40 the facility pallets and to place them in the waste stack using a push-pull attachment or, in the  
41 case of an SLB2, the SLB2 will be lifted from the facility pallet and placed directly on the floor of  
42 the emplacement room. The waste will be emplaced room by room in Panels 1 through 8. Each  
43 panel will be closed off when filled. If a waste container is damaged during the Disposal Phase,  
44 it will be immediately overpacked or repaired. CH TRU mixed waste containers will be

1 continuously vented. The filter vents will allow aspiration, preventing internal pressurization of  
2 the container and minimizing the buildup of flammable gas concentrations.

3 Once a waste panel is mined and any initial ground control established, flow control devices will  
4 be constructed to assure adequate control over ventilation during waste emplacement activities.  
5 The first room to be filled with waste will be Room 7, which is the one that is farthest from the  
6 main access ways. A ventilation control point will be established for Room 7 either just outside  
7 the exhaust side of Room 6 or at the inlet side of Room 7. This ventilation control point will  
8 consist of a flow control device (e.g., bulkhead with a ventilation regulator, or brattice cloth  
9 barricade). When RH TRU mixed waste canister emplacement is completed in a room, CH TRU  
10 mixed waste emplacement can begin in that room. Stacking of CH waste will begin at the  
11 exhaust side of the room and proceed down the access drift, through the room and up the  
12 intake access drift until the entrance of Room 6 is reached. At that point, a brattice cloth and  
13 chain link barricade and, if necessary, bulkheads will be emplaced. This process will be  
14 repeated for Room 6, and so on until Room 1 is filled. At that point, the panel closure system will  
15 be constructed.

16 The emplacement of CH TRU mixed waste into the HWDUs will typically be in the order  
17 received and unloaded from the Contact Handled Packaging. There is no specification for the  
18 amount of space to be maintained between the waste containers themselves, or between the  
19 waste containers and the walls. Containers will be stacked in the best manner to provide  
20 stability for the stack (which is up to three containers high) and to make best use of available  
21 space. It is anticipated that the space between the wall and the container could be from 8 to 18  
22 in. (20 to 46 cm). This space is a function of disposal room wall irregularities, container type,  
23 and sequence of emplacement. Bags of backfill will occupy some of this space. Space is  
24 required over the stacks of containers to assure adequate ventilation for waste handling  
25 operations. A minimum of 16 in. (41 cm) was specified in the Final Design Validation Report  
26 (Appendix D1, Chapter 12 of the WIPP RCRA Part B Permit Application (DOE, 1997)) to  
27 maintain air flow. Typically, the space above a stack of containers will be 36 to 48 in. (90 to 122  
28 cm). However 18 in. (0.45 m) will contain backfill material consisting of bags of Magnesium  
29 Oxide (MgO). Figure A2-8 shows a typical container configuration, although this figure does not  
30 mix containers on any row. Such mixing, while inefficient, will be allowed to assure timely  
31 movement of waste into the underground. No aisle space will be maintained for personnel  
32 access to emplaced waste containers. No roof maintenance behind stacks of waste is planned.

33 The anticipated schedule for the filling of each of the Underground HWDUs known as Panels 1  
34 through 8 is shown in Permit Attachment G, Table G-1. Panel closure in accordance with the  
35 Closure Plan in Permit Attachment G and Permit Attachment G1 is estimated to require an  
36 additional 150 days.

37 Figure A2-12 is a flow diagram of the CH TRU mixed waste handling process.

### 38 A2-3 Waste Characterization

39 TRU mixed waste characterization is described in Permit Attachment C.

### 40 A2-4 Treatment Effectiveness

41 TRU mixed waste treatment, as defined in 20.4.1.101 NMAC (incorporating 40 CFR §260.10),  
42 for which a permit is required, will not be performed at the WIPP facility.

1 A2-5 Maintenance, Monitoring, and Inspection

2 A2-5a Maintenance

3 A2-5a(1) Ground-Control Program

4 The ground-control program at the WIPP facility will ensure that any room in an HWDU in which  
5 waste will be placed will be sufficiently supported to assure compliance with the applicable  
6 portions of the Land Withdrawal Act (**LWA**), which requires a regular review of roof-support  
7 plans and practices by the Mine Safety and Health Administration (**MSHA**). Support is installed  
8 to the requirements of 30 CFR §57, Subpart B.

9 A2-5b Monitoring

10 A2-5b(1) Groundwater Monitoring

11 Groundwater monitoring for the WIPP Underground HWDUs will be conducted in accordance  
12 with Part 5 and Permit Attachment L of this permit.

13 A2-5b(2) Geomechanical Monitoring

14 The geomechanical monitoring program at the WIPP facility is an integral part of the ground-  
15 control program (See Figure A2-13). HWDUs, drifts, and geomechanical test rooms will be  
16 monitored to provide confirmation of structural integrity. Geomechanical data on the  
17 performance of the repository shafts and excavated areas will be collected as part of the  
18 geotechnical field-monitoring program. The results of the geotechnical investigations will be  
19 reported annually. The report will describe monitoring programs and geomechanical data  
20 collected during the previous year.

21 A2-5b(2)(a) Description of the Geomechanical Monitoring System

22 The Geomechanical Monitoring System (**GMS**) provides in situ data to support the continuous  
23 assessment of the design for underground facilities. Specifically, the GMS provides for:

- 24
- 25 • Early detection of conditions that could affect operational safety
  - 26 • Evaluation of disposal room closure that ensures adequate access
  - 27 • Guidance for design modifications and remedial actions
  - 28 • Data for interpreting the behavior of underground openings, in comparison with  
29 established design criteria

29 The instrumentation in Table A2-2 is available for use in support of the geomechanical program.

30 The minimum instrumentation for each of the eight panels will be one borehole extensometer  
31 installed in the roof at the center of each disposal room. The roof extensometers will monitor the  
32 dilation of the immediate salt roof beam and possible bed separations along clay seams.  
33 Additional instrumentation will be installed as conditions warrant.

1 Remote polling of the geomechanical instrumentation will be performed at least once every  
2 month. This frequency may be increased to accommodate any changes that may develop.

3 The results from the remotely read instrumentation will be evaluated after each scheduled  
4 polling. Documentation of the results will be provided annually in the Geotechnical Analysis  
5 Report.

6 Data from remotely read instrumentation will be maintained as part of a geotechnical  
7 instrumentation system. The instrumentation system provides for data maintenance, retrieval,  
8 and presentation. The Permittees will retrieve the data from the instrumentation system and  
9 verify data accuracy by confirming the measurements were taken in accordance with applicable  
10 instructions and equipment calibration is known. Next, the Permittees will review the data after  
11 each polling to assess the performance of the instrument and of the excavation. Anomalous  
12 data will be investigated to determine the cause (instrumentation problem, error in recording,  
13 changing rock conditions). The Permittees will calculate various parameters such as the change  
14 between successive readings and deformation rates. This assessment will be reported to the  
15 Permittees' cognizant ground control engineer and operations personnel. The Permittees will  
16 investigate unexpected deformation to determine if remediation is needed.

17 The stability of an open panel excavation is generally determined by the rock deformation rate.  
18 The excavation may be unstable when there is a continuous increase in the deformation rate  
19 that cannot be controlled by the installed support system. The Permittees will evaluate the  
20 performance of the excavation. These evaluations assess the effectiveness of the roof support  
21 system and estimate the stand-up time of the excavation. If an open panel shows the trend is  
22 toward adverse (unstable) conditions, the results will be reported to determine if it is necessary  
23 to terminate waste disposal activities in the open panel. This report of the trend toward adverse  
24 conditions in an open HWDU will also be provided to the Secretary of the NMED within seven  
25 (7) calendar days of issuance of the report.

#### 26 A2-5b(2)(b) System Experience

27 Much experience in the use of geomechanical instrumentation was gained as the result of  
28 performance monitoring of Panel 1, which began at the time of completion of the panel  
29 excavation in 1988. The monitoring system installed at that time involved simple measurements  
30 and observations (e.g., vertical and horizontal convergence rates, and visual inspections).  
31 Minimal maintenance of instrumentation is required, and the instrumentation is easily replaced if  
32 it malfunctions. Conditions throughout Panel 1 are well known. The monitoring program  
33 continues to provide data to compare the performance of Panel 1 with that established  
34 elsewhere in the underground. Panel 1 performance is characterized by the following:

- 35 • The development of bed separations and lateral shifts at the interfaces of the salt  
36 and the clays underlying the anhydrites "a" and "b."
- 37 • Room closures. A closure due only to the roof movement will be separated from  
38 the total closure.
- 39 • The behavior of the pillars.
- 40 • Fracture development in the roof and floor.

- Distribution of load on the support system.

Roof conditions are assessed from observation boreholes and extensometer measurements. Measurements of room closure, rock displacements, and observations of fracture development in the immediate roof beam are made and used to evaluate the performance of a panel. A description of the Panel 1 monitoring program was presented to the members of the Geotechnical Experts Panel (in 1991) who concurred that it was adequate to determine deterioration within the rooms and that it will provide early warning of deteriorating conditions.

The assessment and evaluation of the condition of WIPP excavations is an interactive, continuous process using the data from the monitoring programs. Criteria for corrective action are continually reevaluated and reassessed based on total performance to date. Actions taken are based on these analyses and planned utilization of the excavation. Because WIPP excavations are in a natural geologic medium, there is inherent variability from point to point. The principle adopted is to anticipate potential ground control requirements and implement them in a timely manner rather than to wait until a need arises.

#### A2-5b(3) Volatile Organic Compound Monitoring

The volatile organic compound monitoring for the WIPP Underground HWDUs will be conducted in accordance with Part 4 and Permit Attachment N of this permit.

#### A2-5c Inspection

The inspection of the WIPP Underground HWDUs will be conducted in accordance with Part 2 and Permit Attachment E of this permit.

#### References

DOE, 1997. Resource Conservation and Recovery Act Part B Permit Application, Waste Isolation Pilot Plant (WIPP), Carlsbad, New Mexico, Revision 6.5, 1997.

DOE, 2009. WIPP Hazardous Waste Facility Permit Amended Renewal Application, Carlsbad, New Mexico, September 2009.

(This page intentionally blank)



1

## TABLES

(This page intentionally blank)

**Table A2-1**  
**CH TRU Mixed Waste Handling Equipment Capacities**

| <b>Capacities for Equipment</b>               |             |
|---|-------------|
| Facility Pallet                               | 25,000 lbs. |
| Facility Transfer Vehicle                     | 26,000 lbs. |
| Underground transporter                       | 28,000 lbs. |
| Underground forklift                          | 12,000 lbs. |
| <b>Maximum Gross Weights of Containers</b>    |             |
| Seven-pack of 55-gallon drums                 | 7,000 lbs.  |
| Four-pack of 85-gallon drums                  | 4,500 lbs.  |
| Three-pack of 100-gallon drums                | 3,000 lbs.  |
| Ten-drum overpack                             | 6,700 lbs.  |
| Standard waste box                            | 4,000 lbs.  |
| Standard large box 2                          | 10,500 lbs. |
| Shielded container                            | 2,260 lbs.  |
| Three-pack of shielded containers             | 7,000 lbs.  |
| <b>Maximum Net Empty Weights of Equipment</b> |             |
| TRUPACT-II                                    | 13,140 lbs. |
| HalfPACT                                      | 10,500 lbs. |
| TRUPACT-III                                   | 43,600 lbs. |
| Facility pallet                               | 4,120 lbs.  |

**Table A2-2  
 Instrumentation Used in Support of the Geomechanical Monitoring System**

| <b>Instrument Type</b>                    | <b>Features</b>  | <b>Parameter Measured</b> | <b>Range</b>  |
|---|--|---------------------------|---|
| Borehole Extensometer                     | The extensometer provides for monitoring the deformation parallel to the borehole axis. Units suitable for up to 5 measurements anchors in addition to the reference head. Maximum borehole depths shall be 50 feet. | Cumulative Deformation    | 0-2 inches  |
| Borehole Television Camera                | Closed circuit television may be used for monitoring areas otherwise inaccessible, such as boreholes or shafts.  | Video Image               | N/A   |
| Convergence Points and Tape Extensometers | Mechanically anchored eyebolts to which a portable tape extensometer is attached.  | Cumulative Deformation    | 2-50 feet   |
| Convergence Meters                        | Includes wire and sonic meters. Mounted on rigid plates anchored to the rock surface.  | Cumulative Deformation    | 2-50 feet   |
| Inclinometers                             | Both vertical and horizontal inclinometers are used. Traversing type of system in which a probe is moved periodically through casing located in the borehole whose inclination is being measured.                    | Cumulative Deformation    | 0-30 degrees  |
| Rock Bolt Load Cells                      | Spool type units suitable for use with rock bolts. Tensile stress is inferred from strain gauges mounted on the surface of the spool.  | Load                      | 0-300 kips  |
| Earth Pressure Cells                      | Installed between concrete keys and rock. Preferred type is a hydraulic pressure plate connected to a vibrating wire transmitter.  | Lithostatic Pressure      | 0-1000 psi  |
| Piezometer Pressure Transducers           | Located in shafts and of robust design and construction. Periodic checks on operability required.  | Fluid Pressure            | 0-500 psi   |
| Strain Gauges                             | Installed within the concrete shaft key. Suitably sealed for the environment. Two types used-- surface mounted and embedded.   | Cumulative Deformation    | 0-3000 $\mu$ in/in (embedded)<br>0-2500 $\mu$ in/in (surface) |

**Table A2-3**  
**RH TRU Mixed Waste Handling Equipment Capacities**

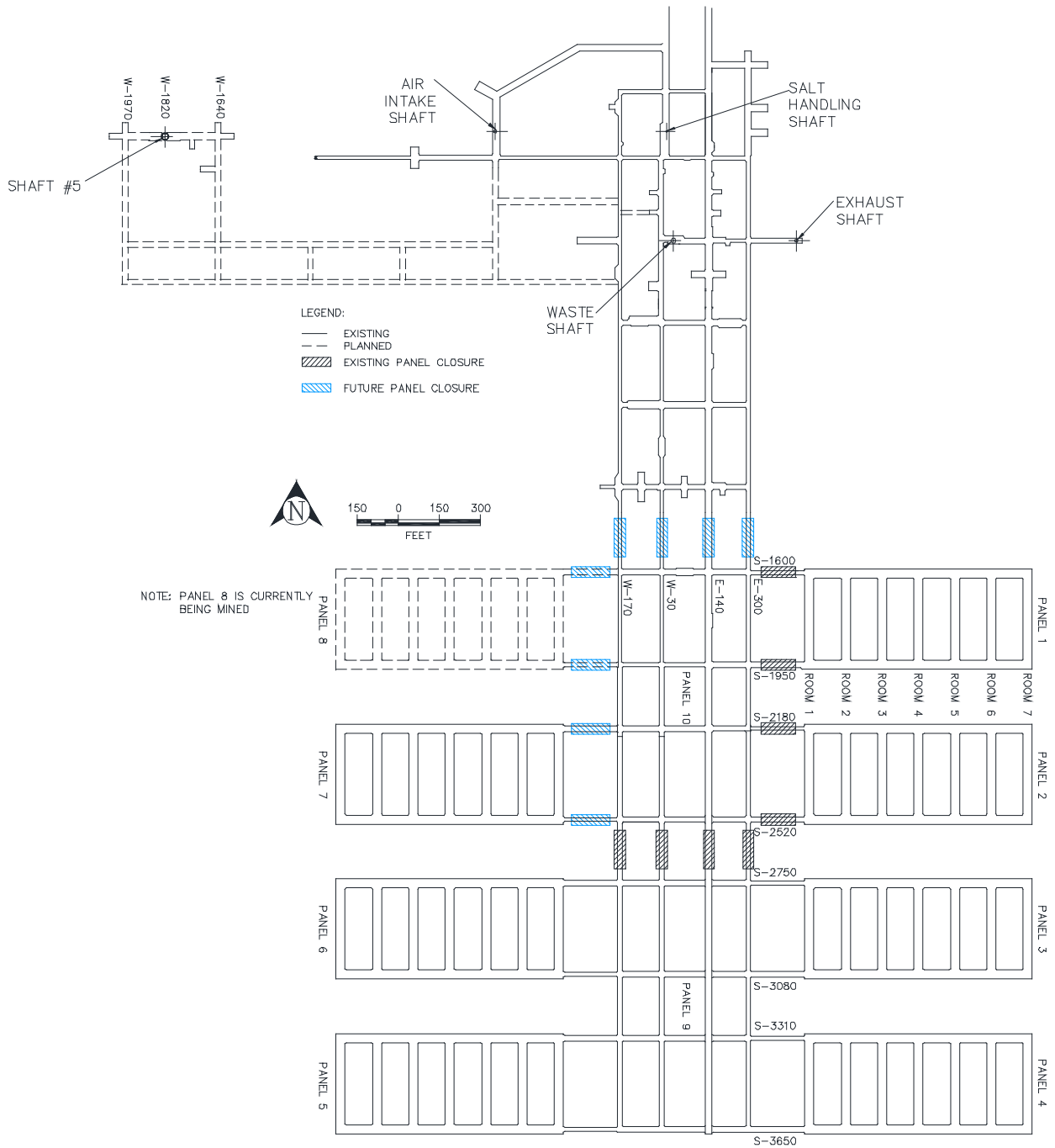
| <b>Capacities for Equipment</b>                   |            |
|---|------------|
| 41-Ton Forklift                                   | 82,000 lbs |
| <b>Maximum Gross Weights of RH TRU Containers</b> |            |
| RH TRU Facility Canister                          | 10,000 lbs |
| 55-Gallon Drum                                    | 1,000 lbs  |
| RH TRU Canister                                   | 8,000 lbs  |
| <b>Maximum Net Empty Weights of Equipment</b>     |            |
| Facility Cask                                     | 67,700 lbs |

(This page intentionally blank)

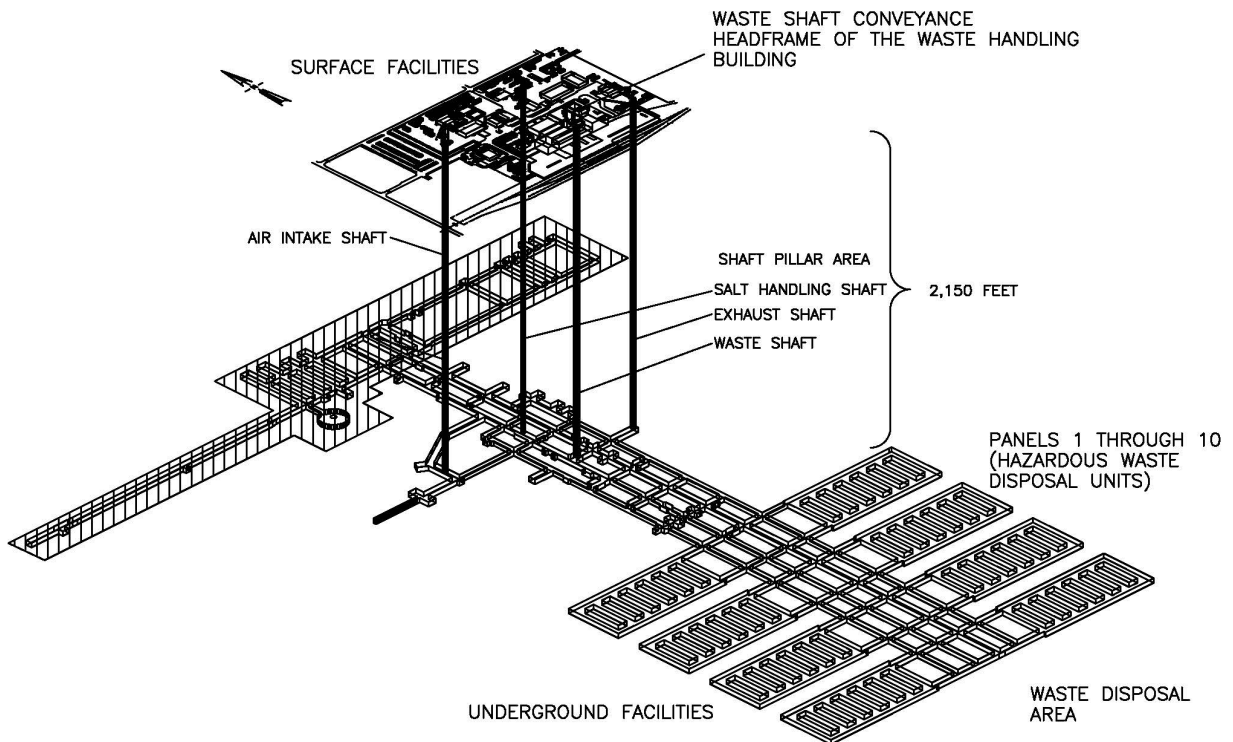
## FIGURES

(This page intentionally blank)

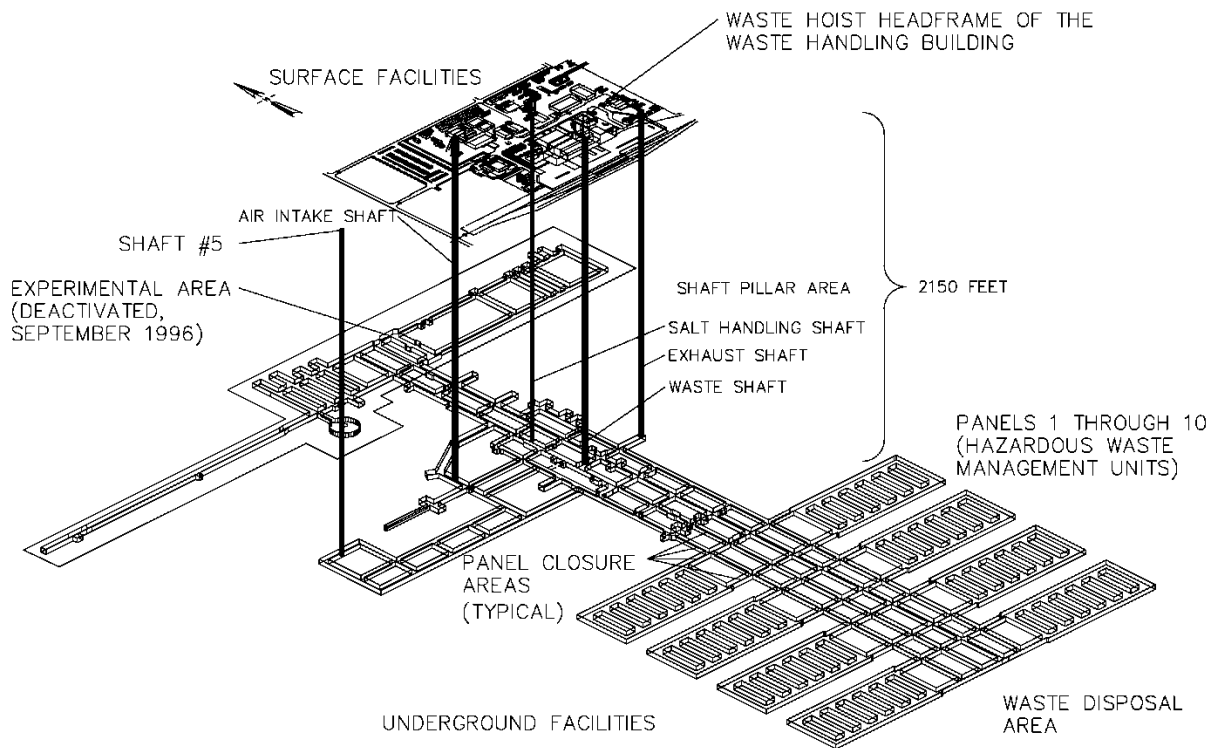




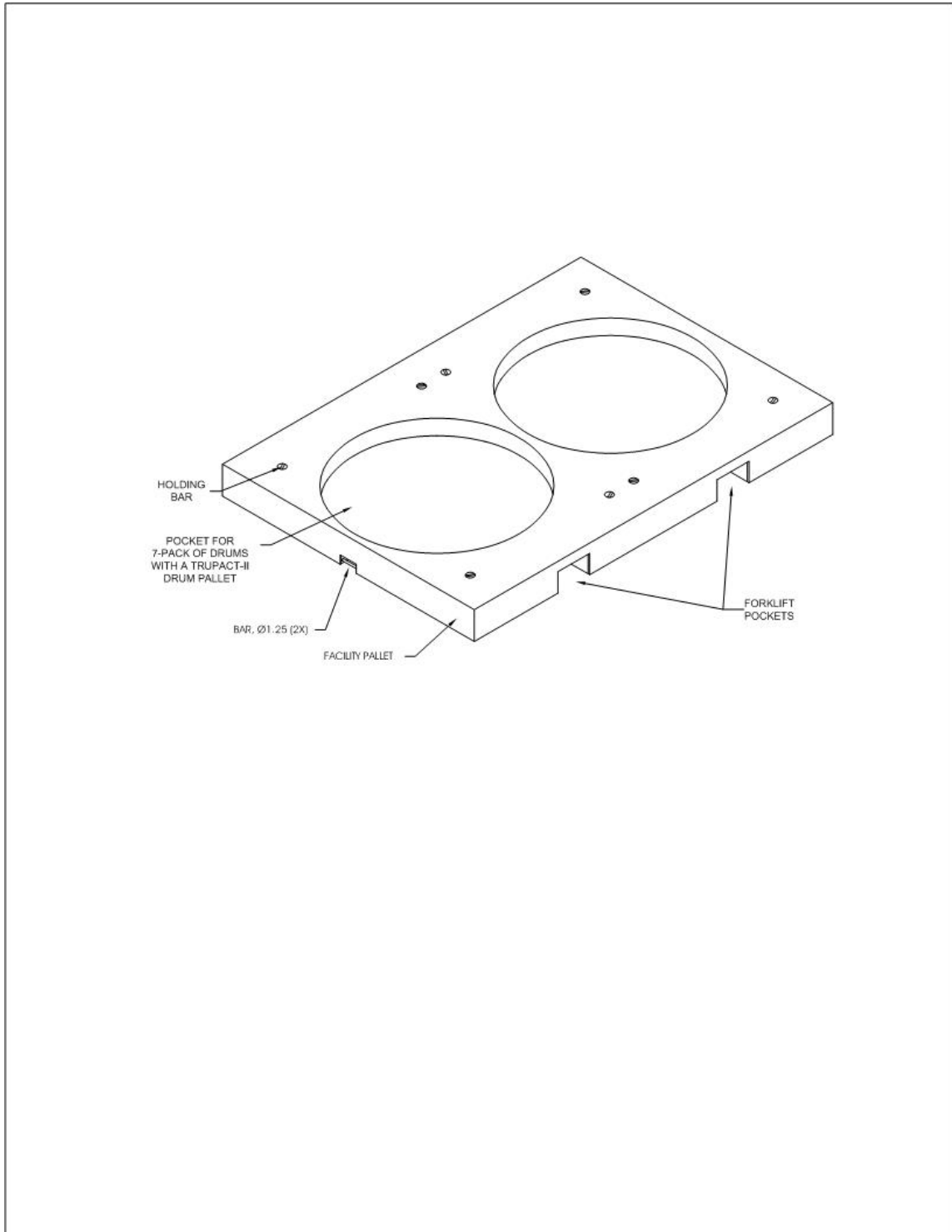
**Figure A2-1  
 Repository Horizon**



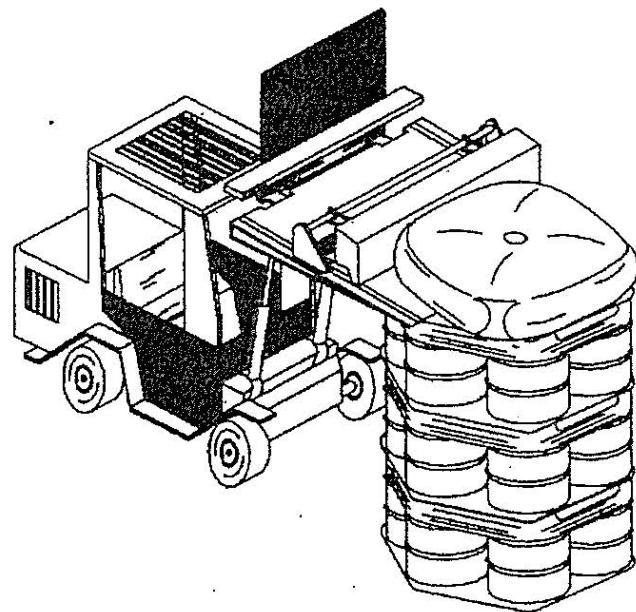
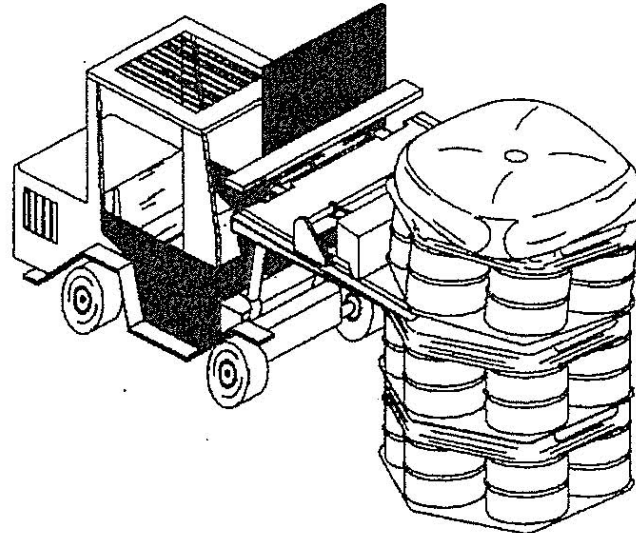
**Figure A2-2**  
**Spatial View of the Miscellaneous Unit and Waste Handling Facility**



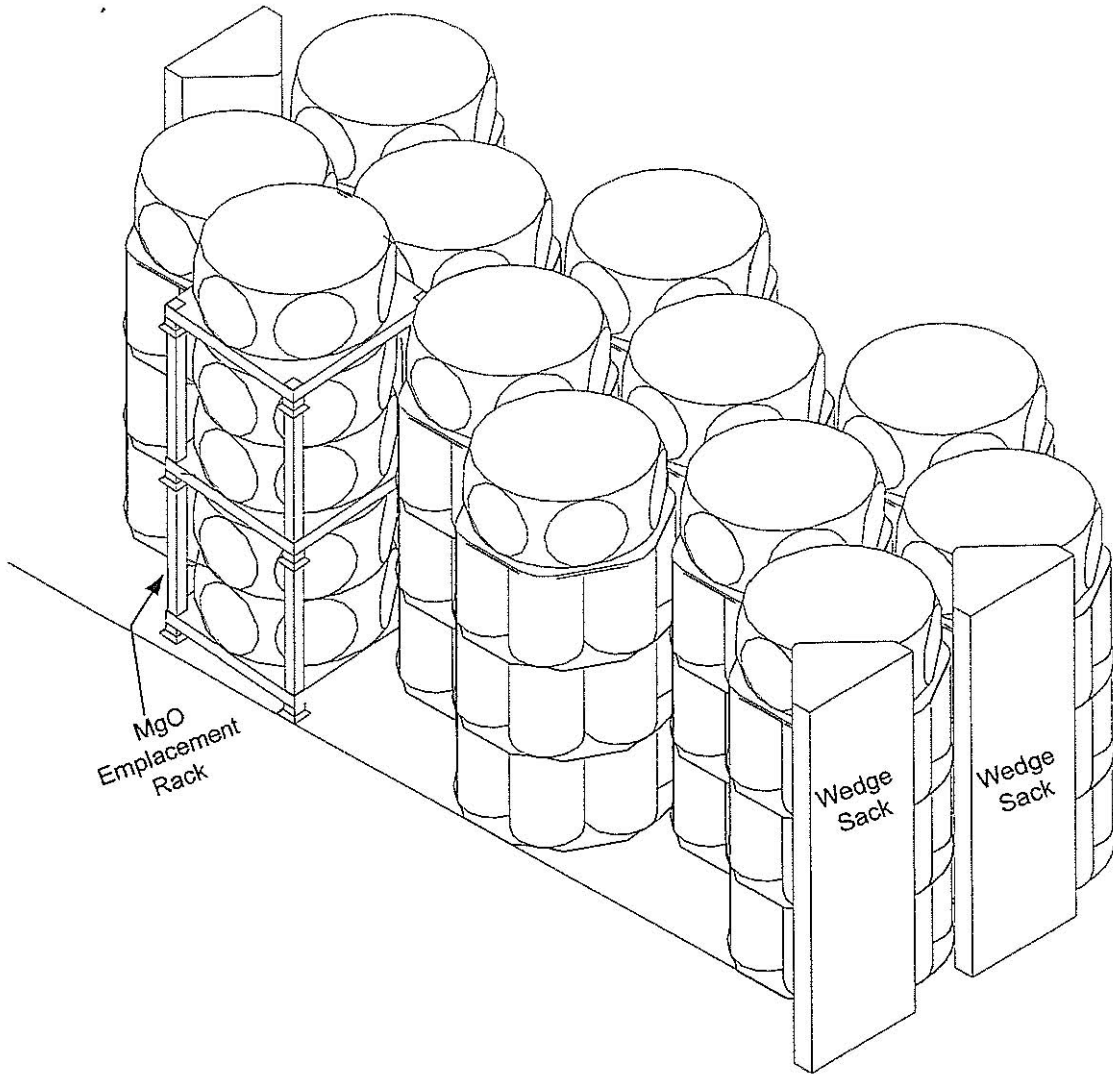
**Figure A2-2-S#5**  
**Spatial View of the Miscellaneous Unit and Waste Handling Facility (with S#5)**



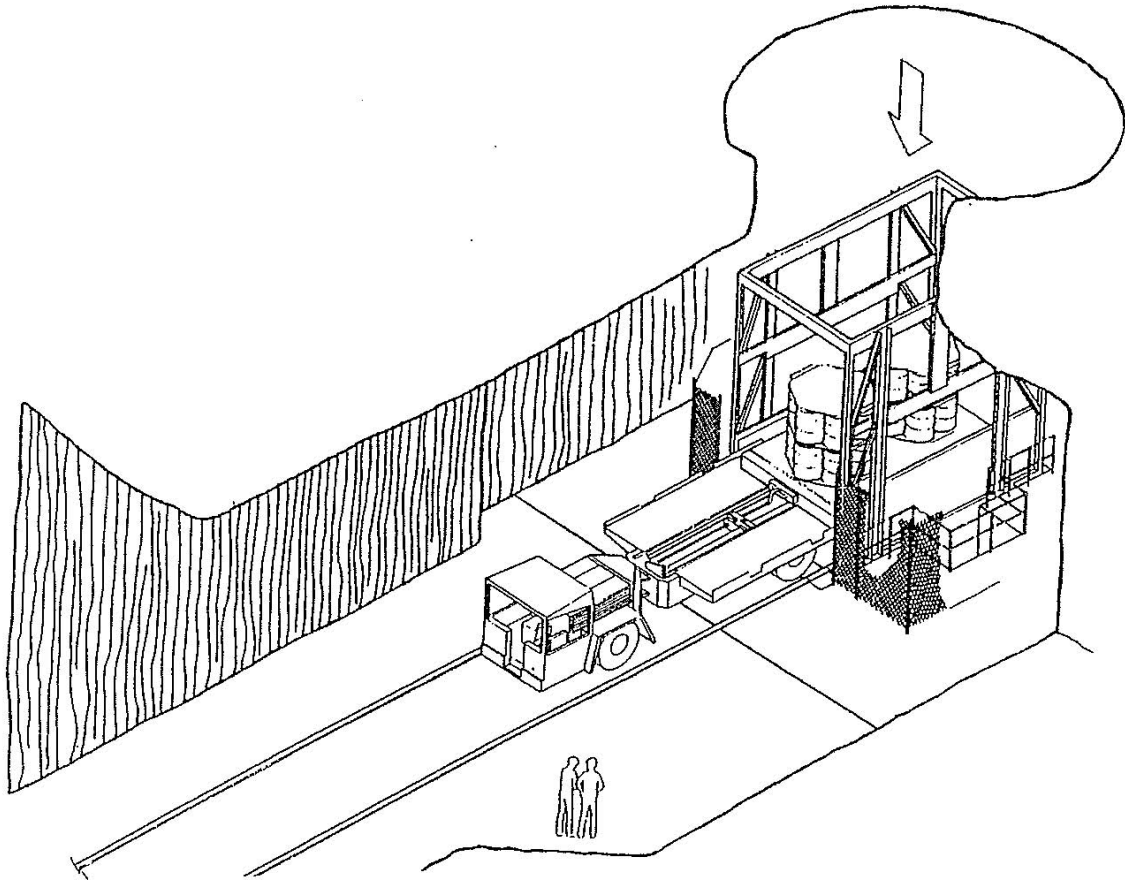
**Figure A2-3**  
**Facility Pallet for Seven-Pack of Drums**



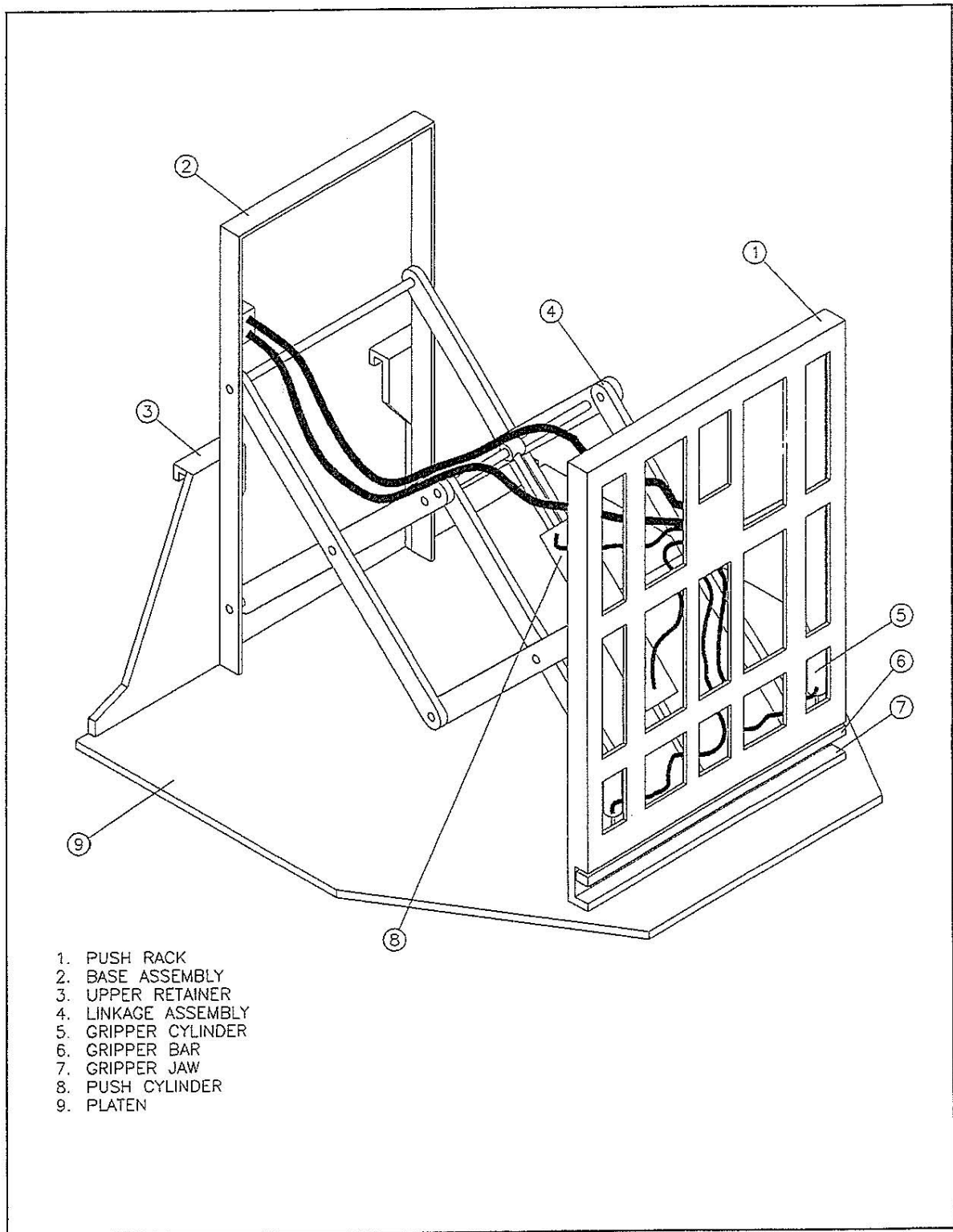
**Figure A2-5**  
**Typical Backfill Sacks Emplaced on Drum Stacks**



**Figure A2-5a**  
**Potential MgO Emplacement Configurations**

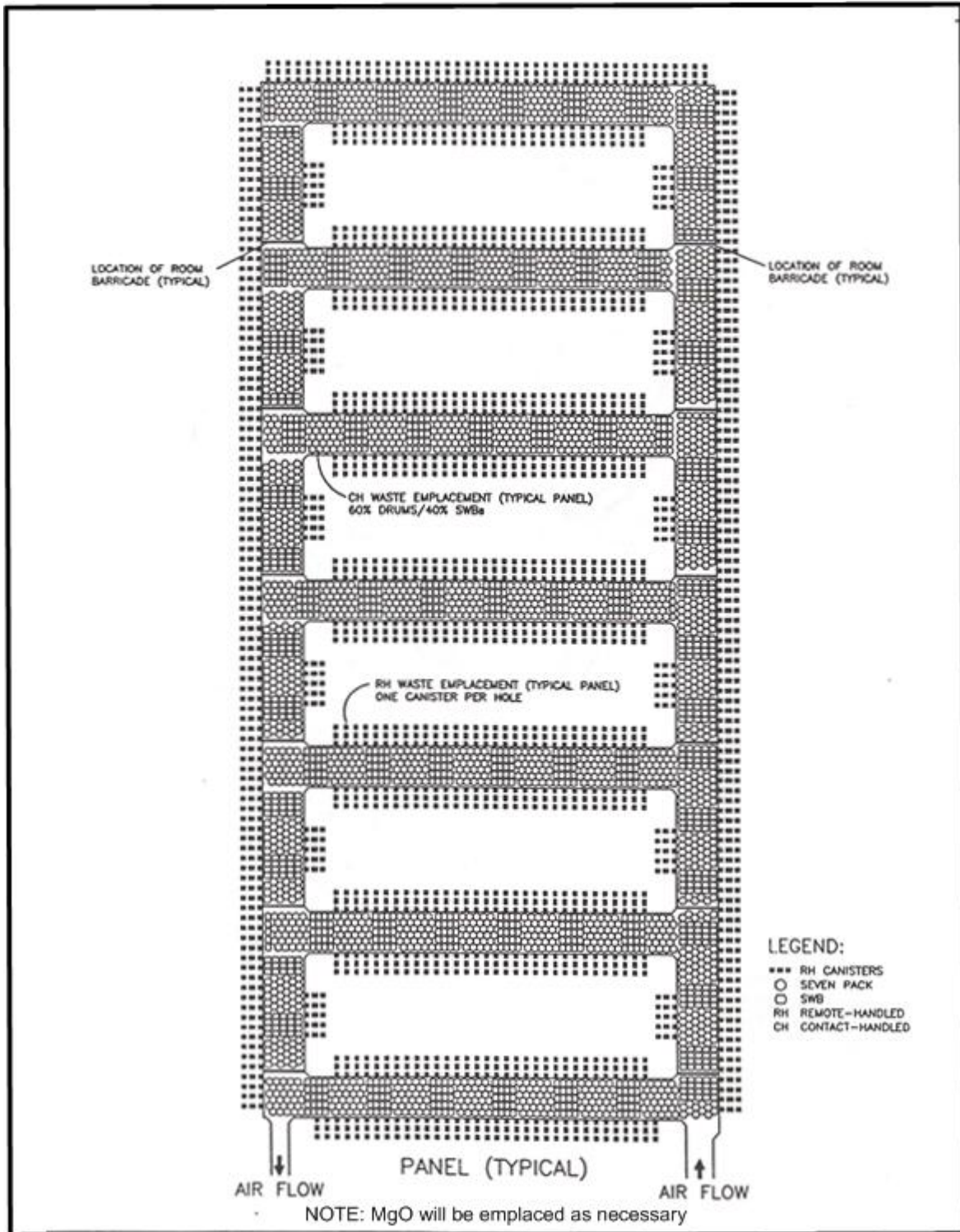


**Figure A2-6**  
**Waste Transfer Cage to Transporter**

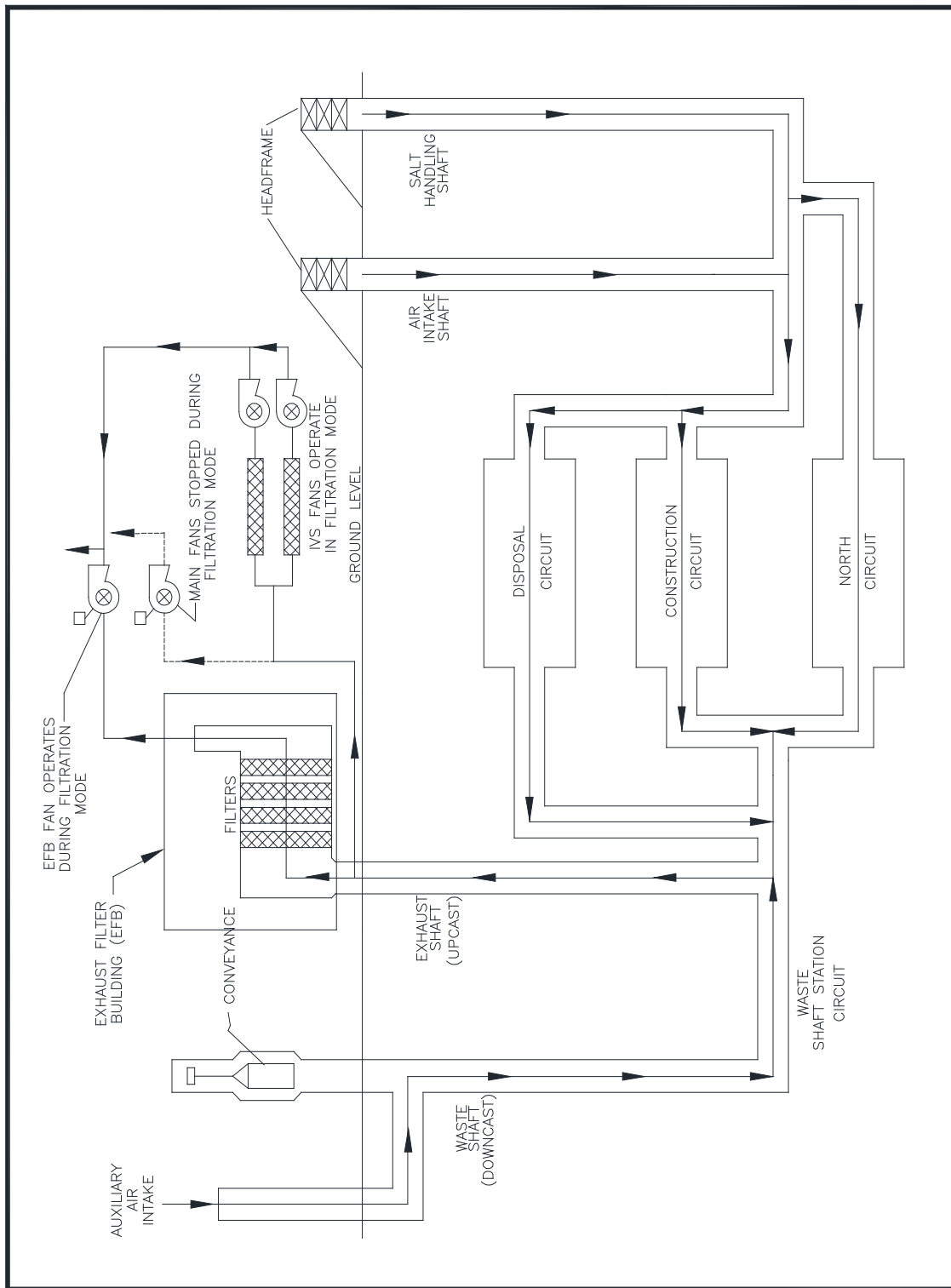


**Figure A2-7**  
**Push-Pull Attachment to Forklift to Allow Handling of Waste Containers**

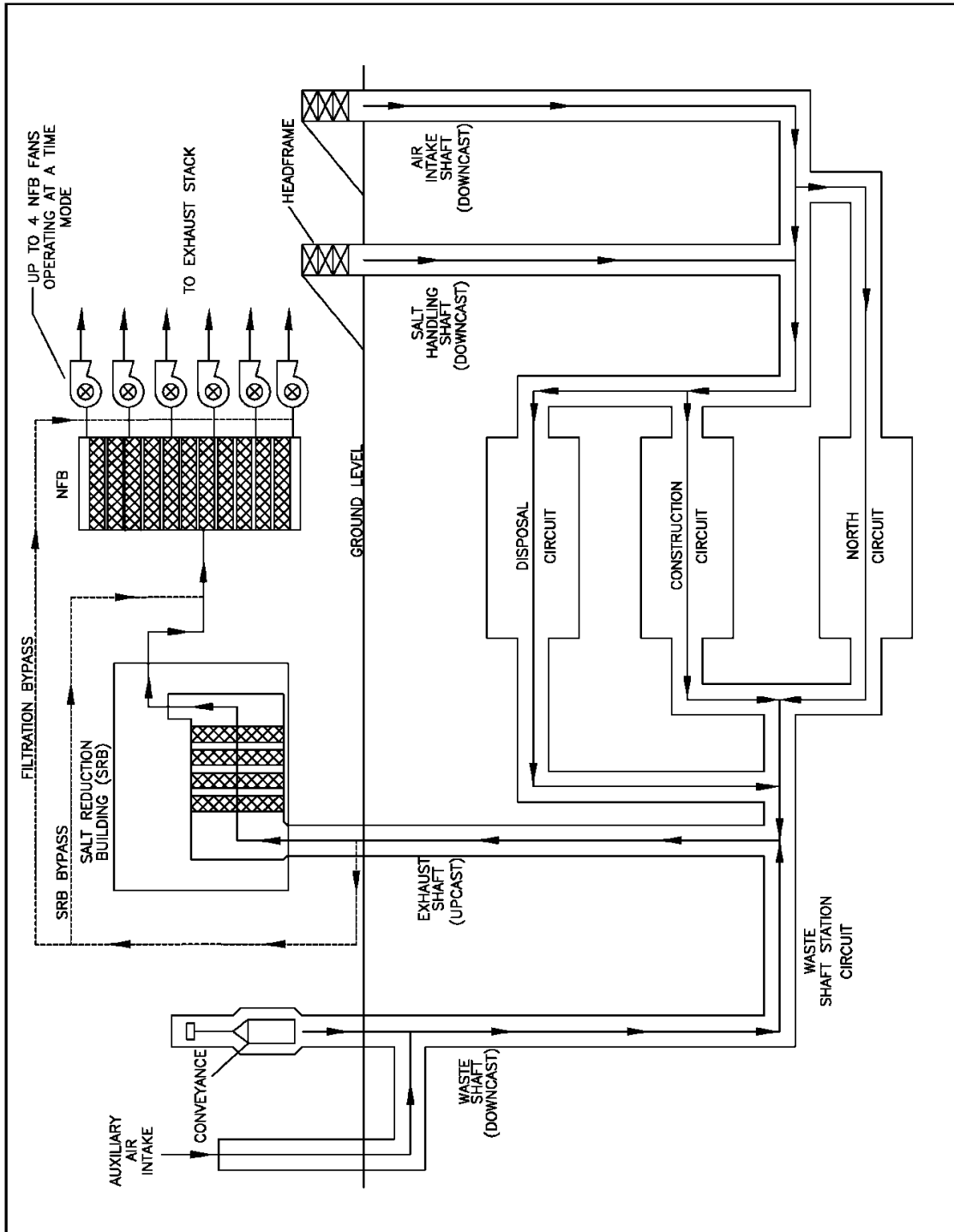




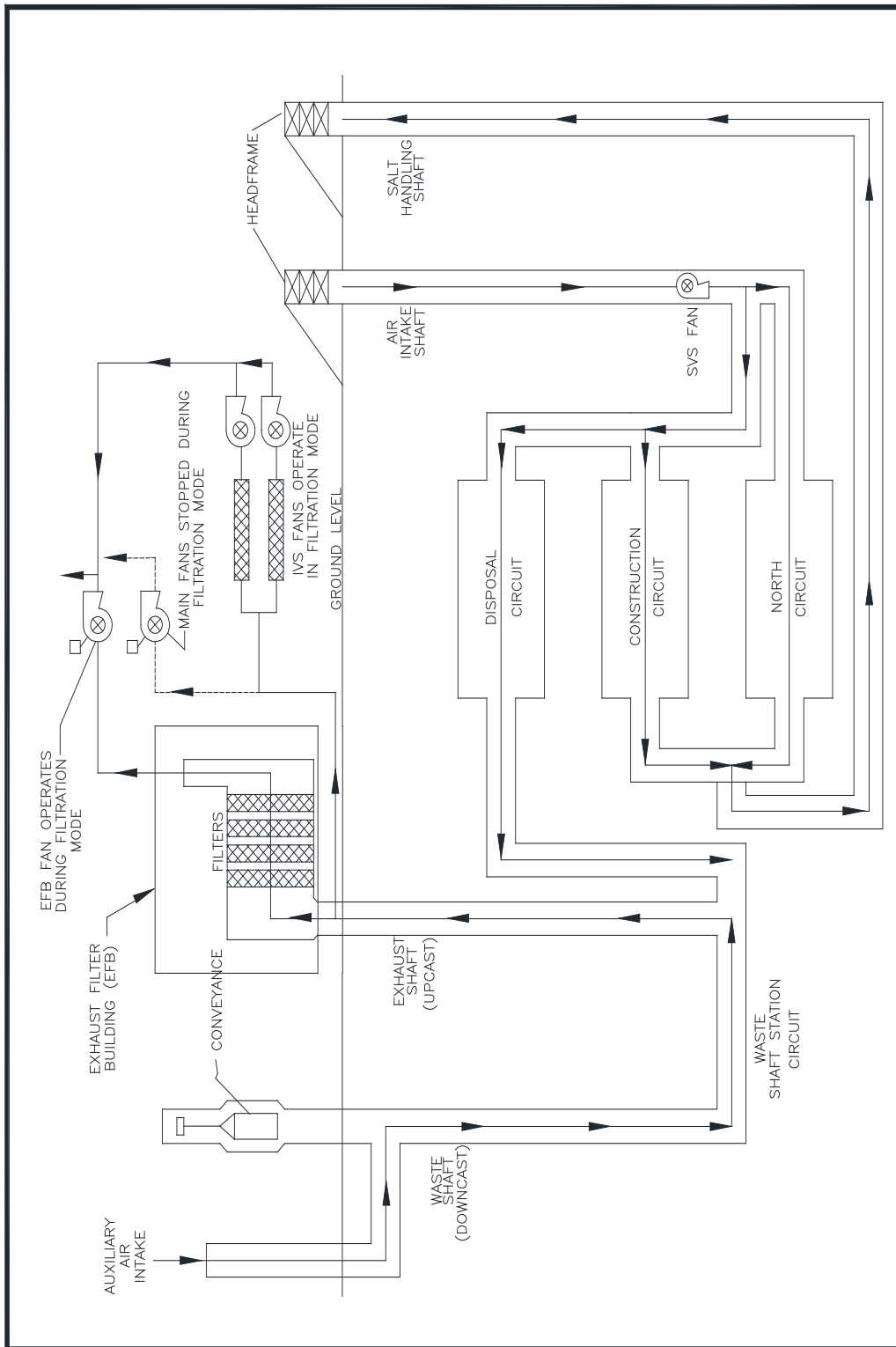
**Figure A2-8**  
**Typical RH and CH Transuranic Mixed Waste Container Disposal Configuration**



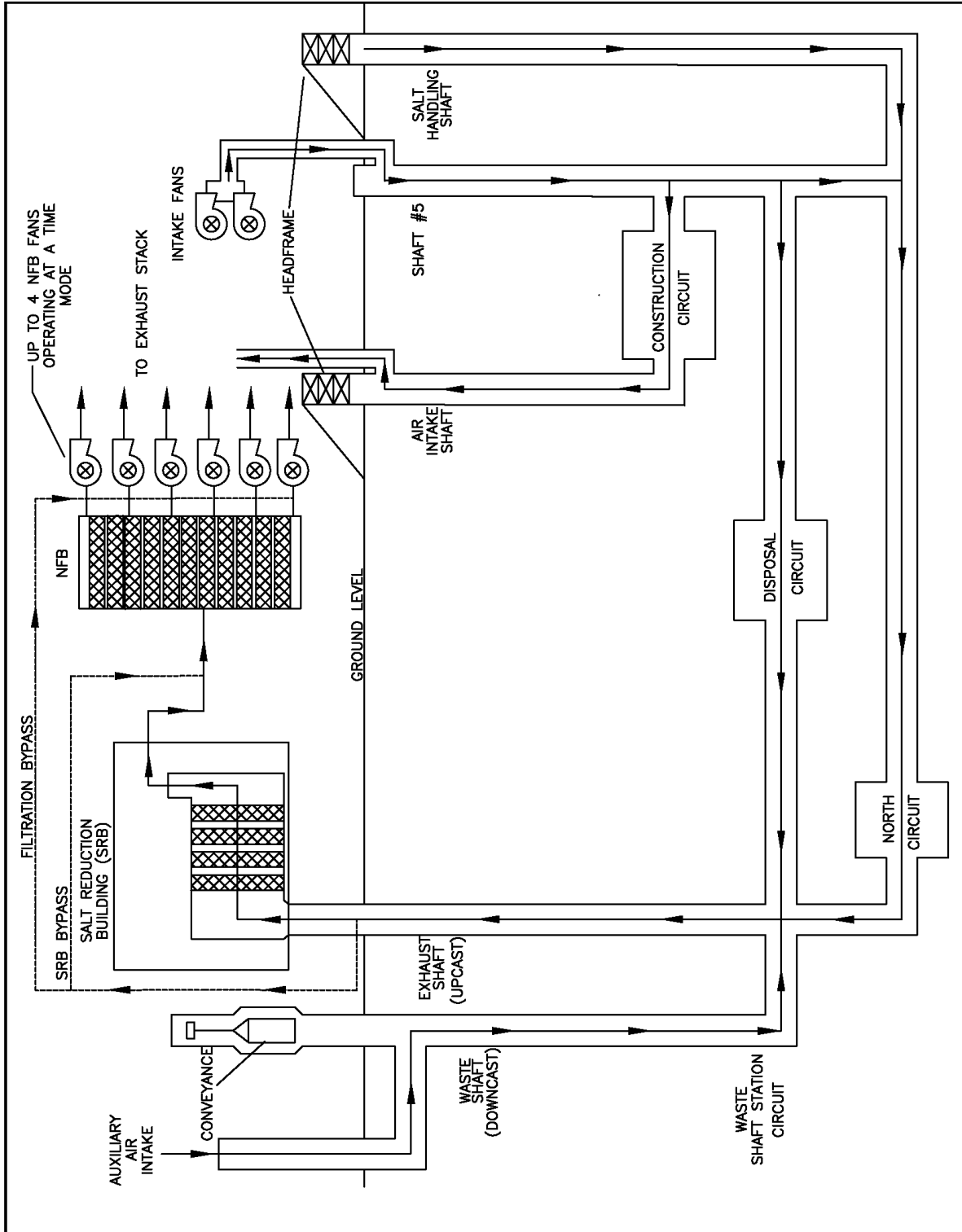
**Figure A2-9a**  
**Underground Ventilation System Airflow**



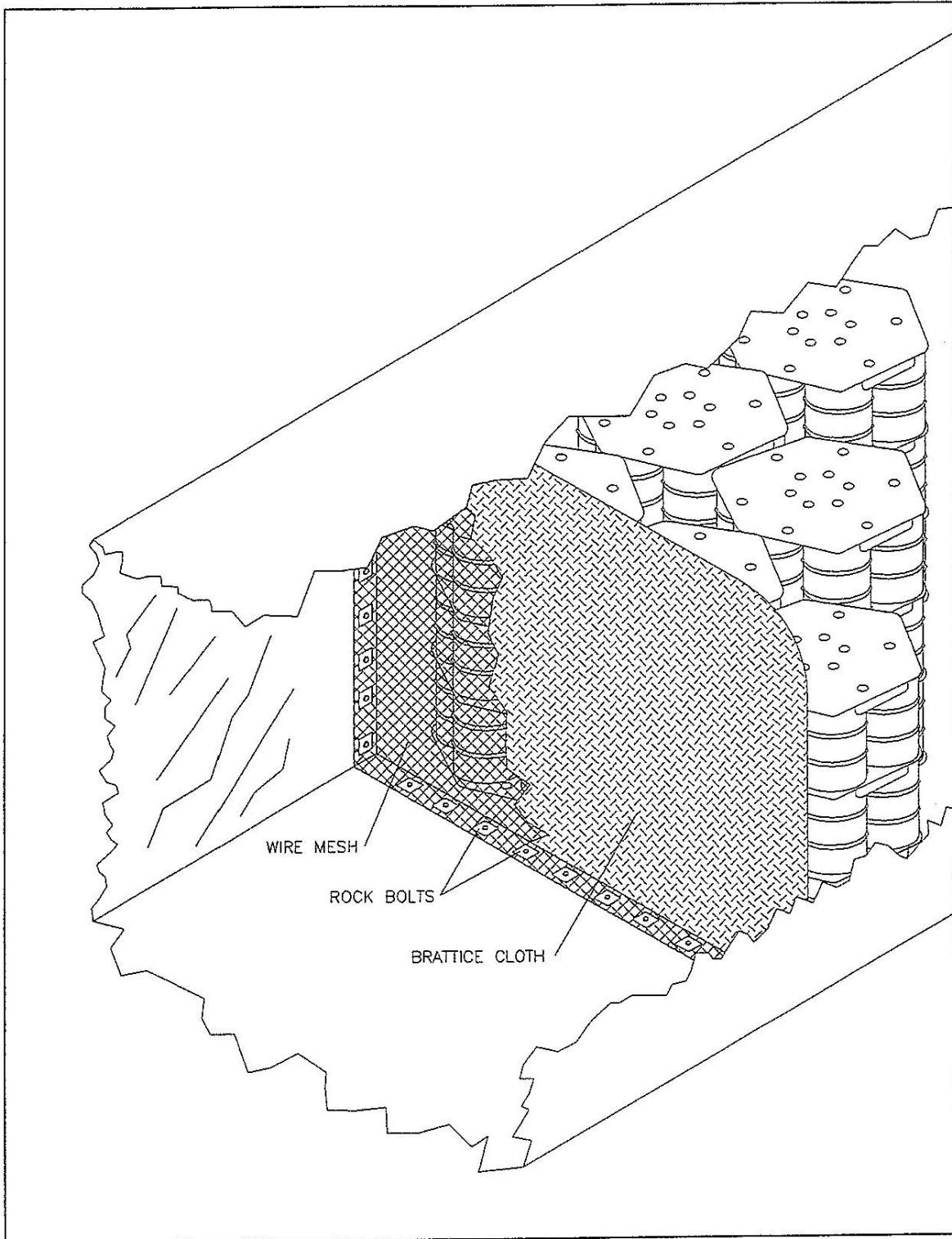
**Figure A2-9a-NFB**  
**Underground Ventilation System Airflow (with Building 416)**



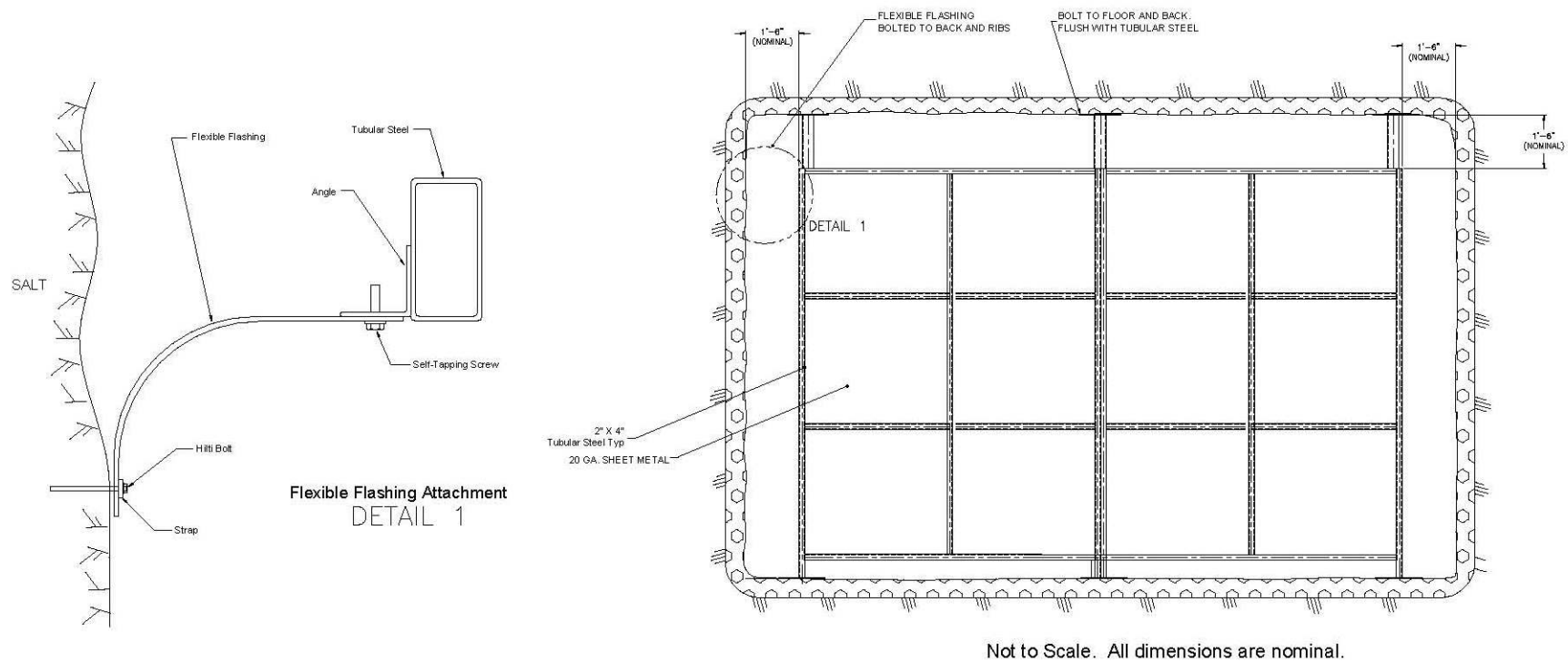
**Figure A2-9b**  
**Underground Ventilation System Airflow (with SVS)**



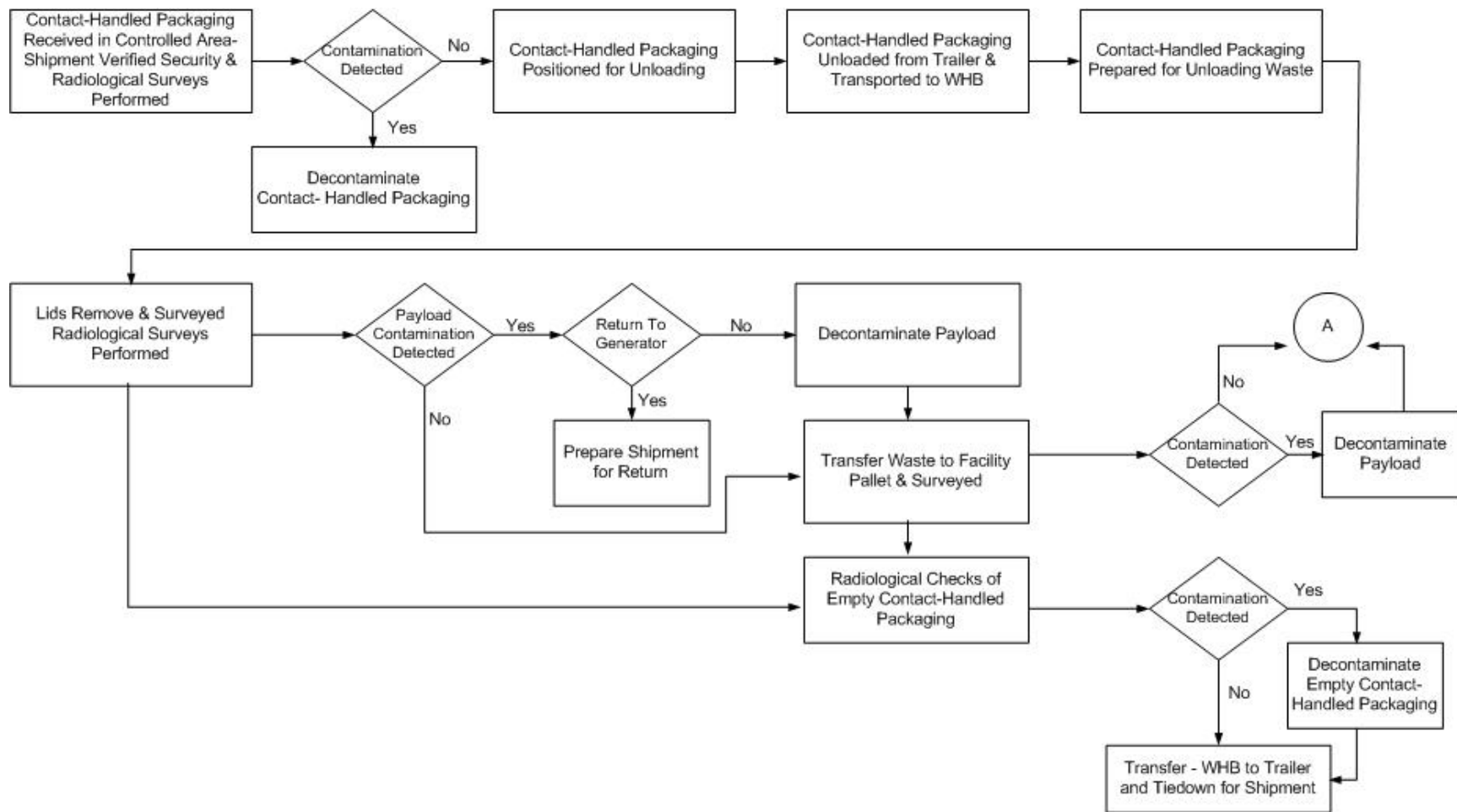
**Figure A2-9c**  
**Underground Ventilation System Airflow (with S#5)**



**Figure A2-11**  
**Typical Room Barricade**

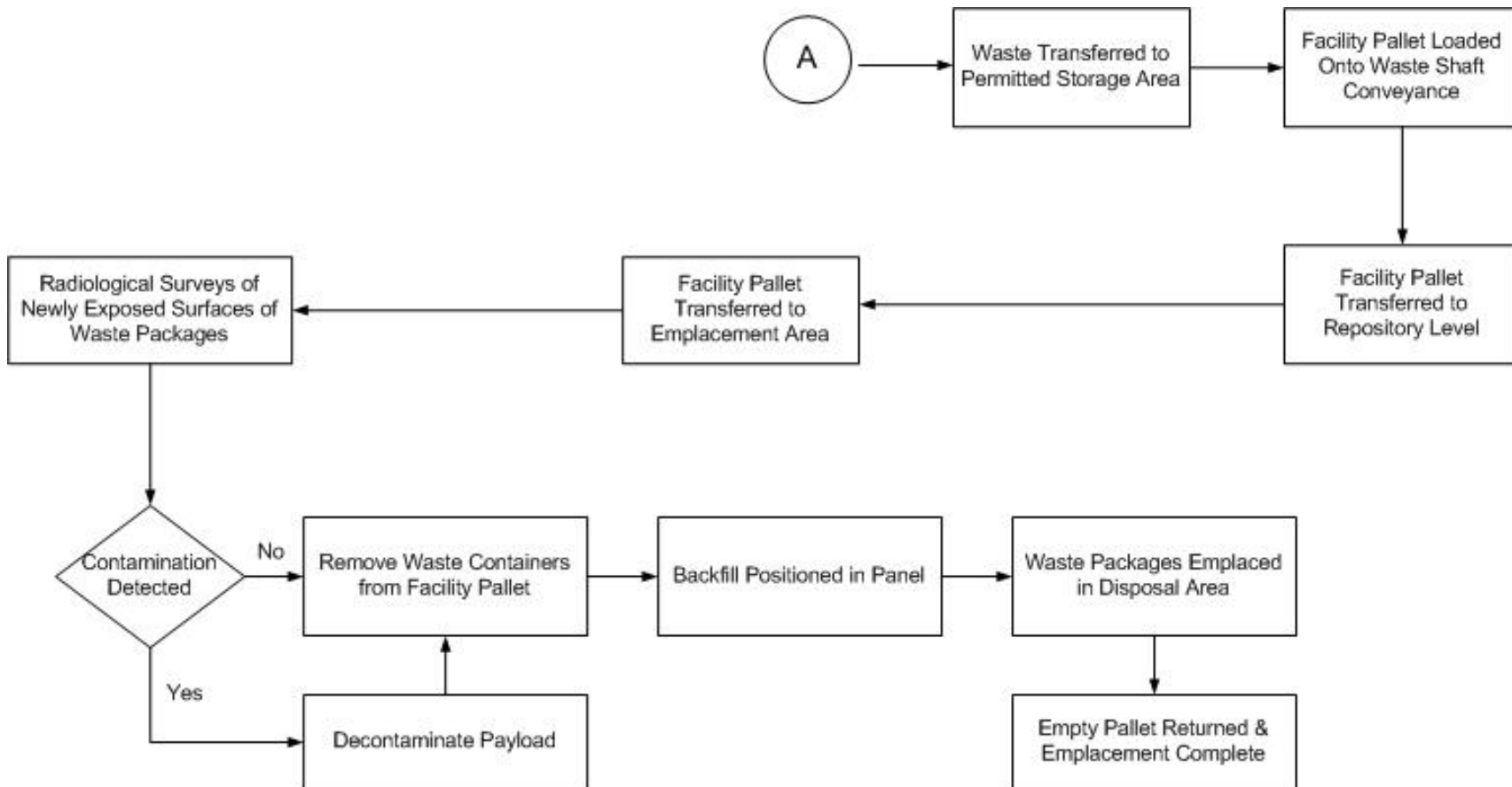


**Figure A2-11a**  
**Typical Bulkhead**



**Figure A2-12**  
**WIPP Facility Surface and Underground CH Transuranic Mixed Waste Process Flow Diagram**





**Figure A2-12**  
**WIPP Facility Surface and Underground CH Transuranic Mixed Waste Process Flow Diagram (Continued)**

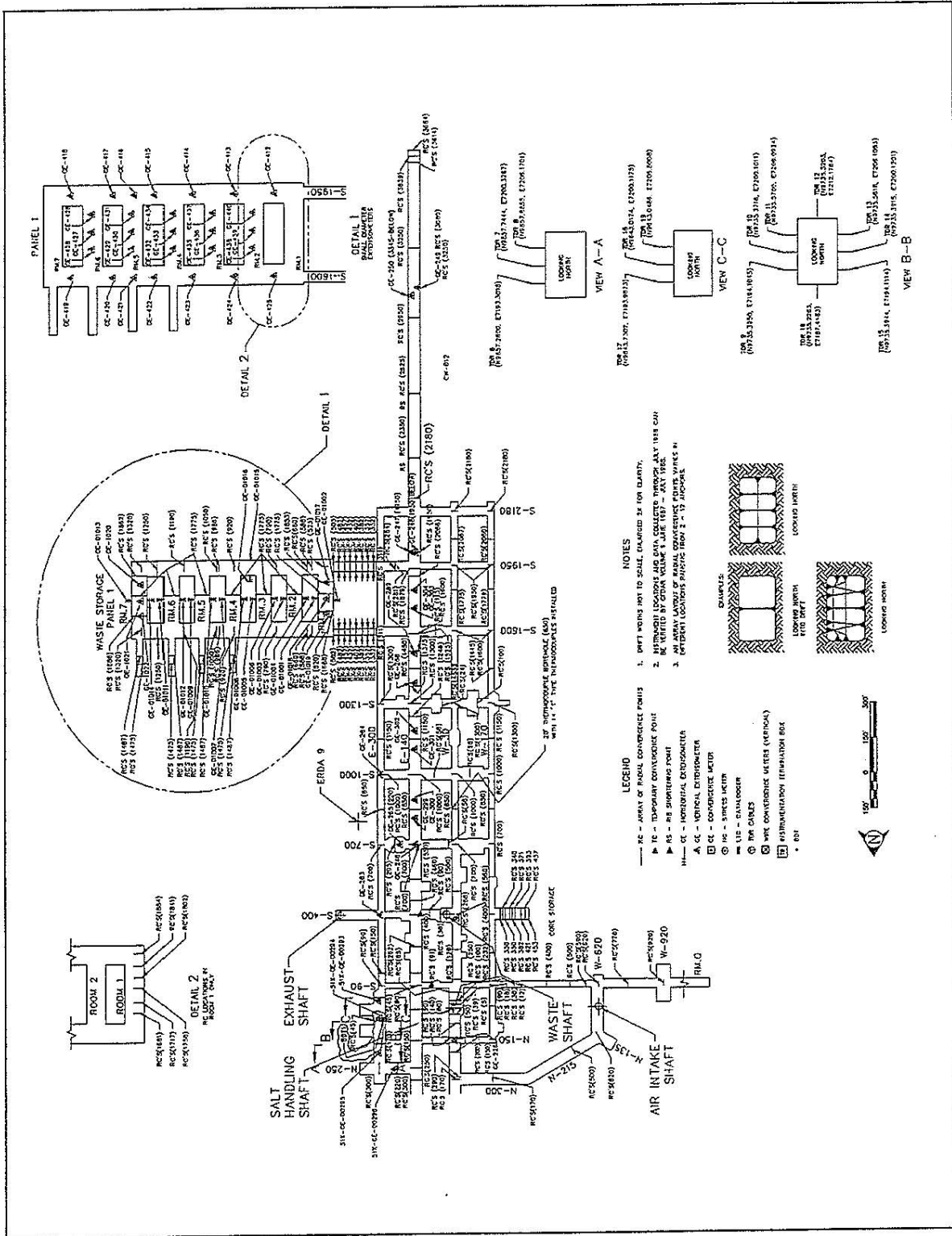
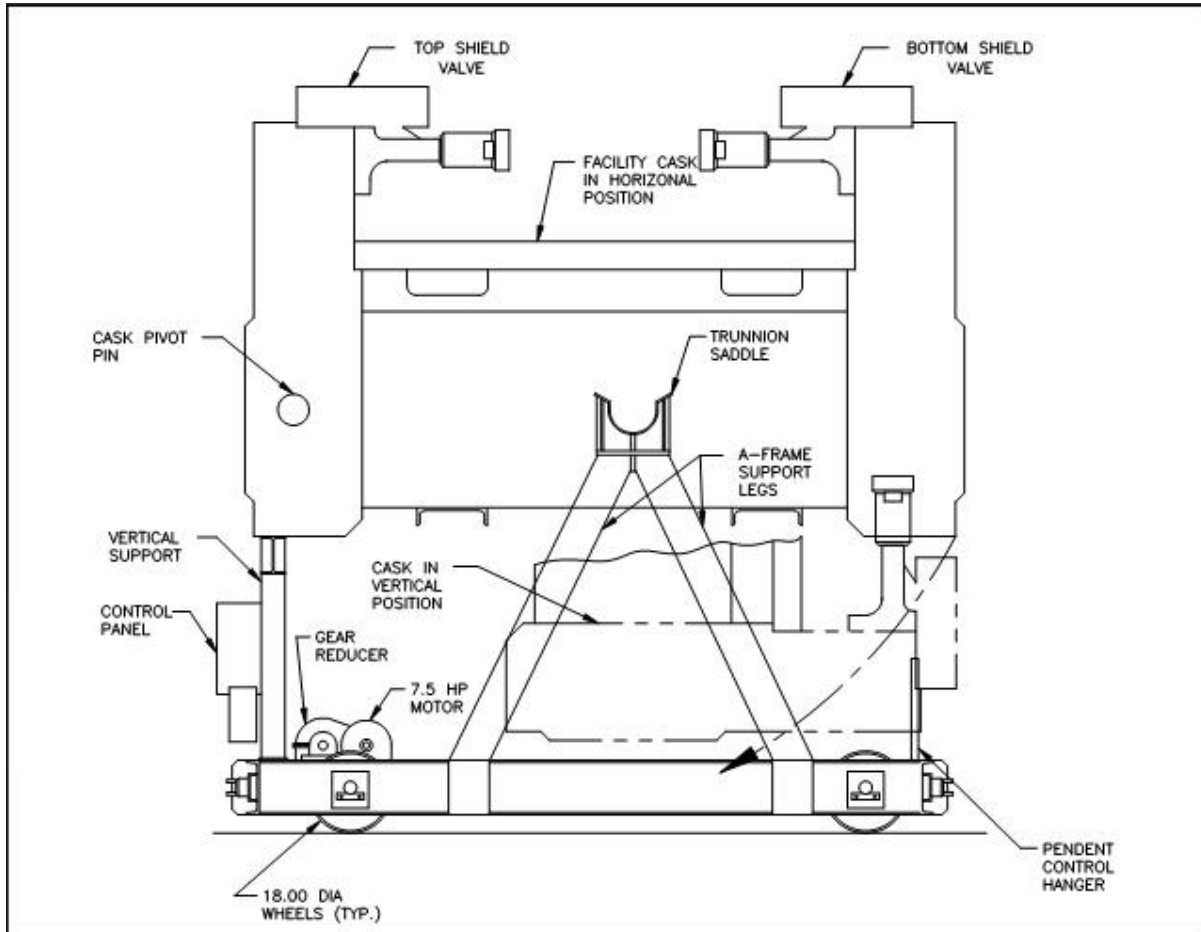
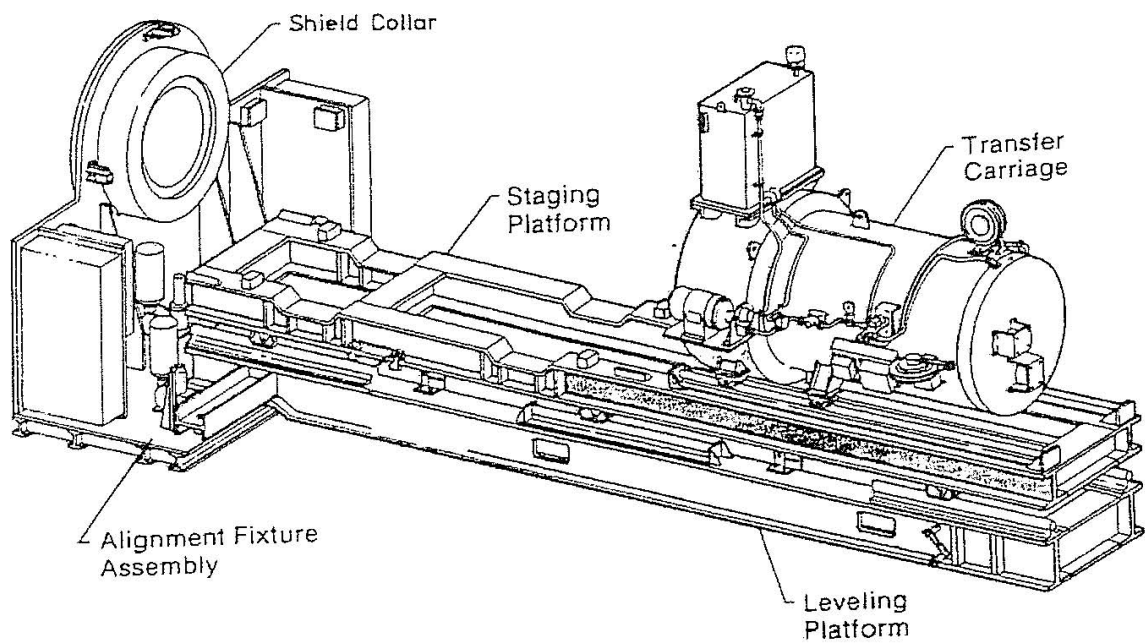


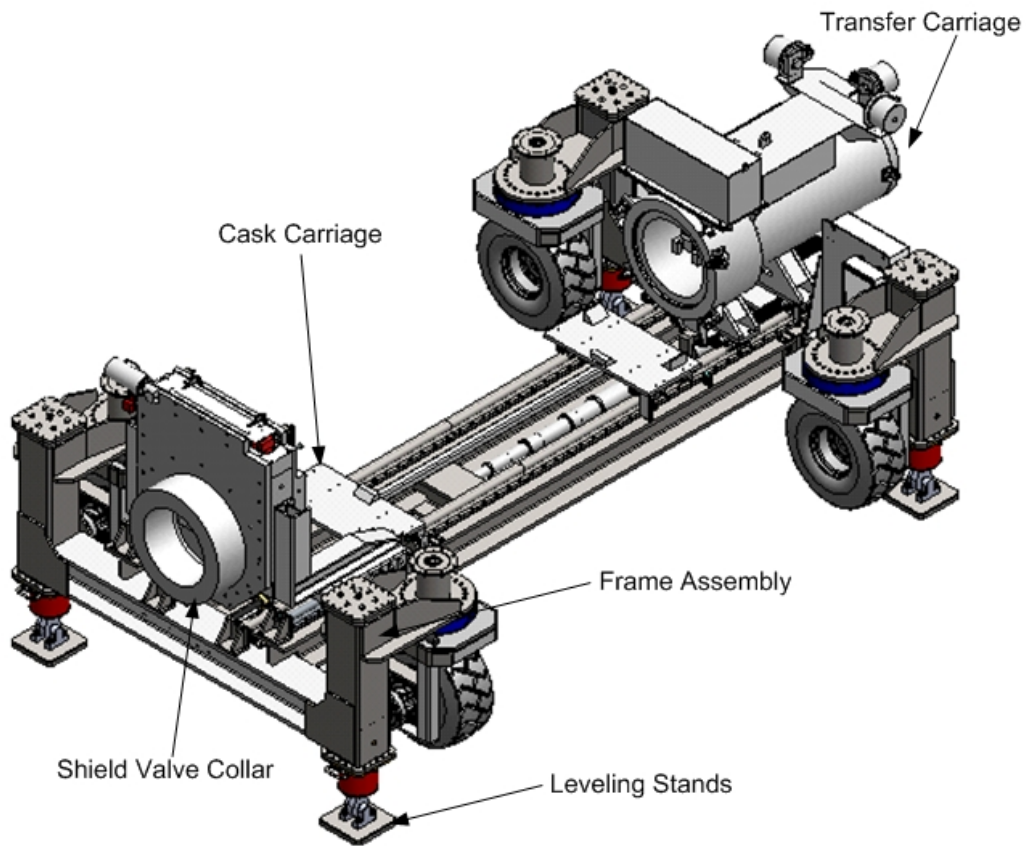
Figure A2-13  
 Layout and Instrumentation - As of 1/96



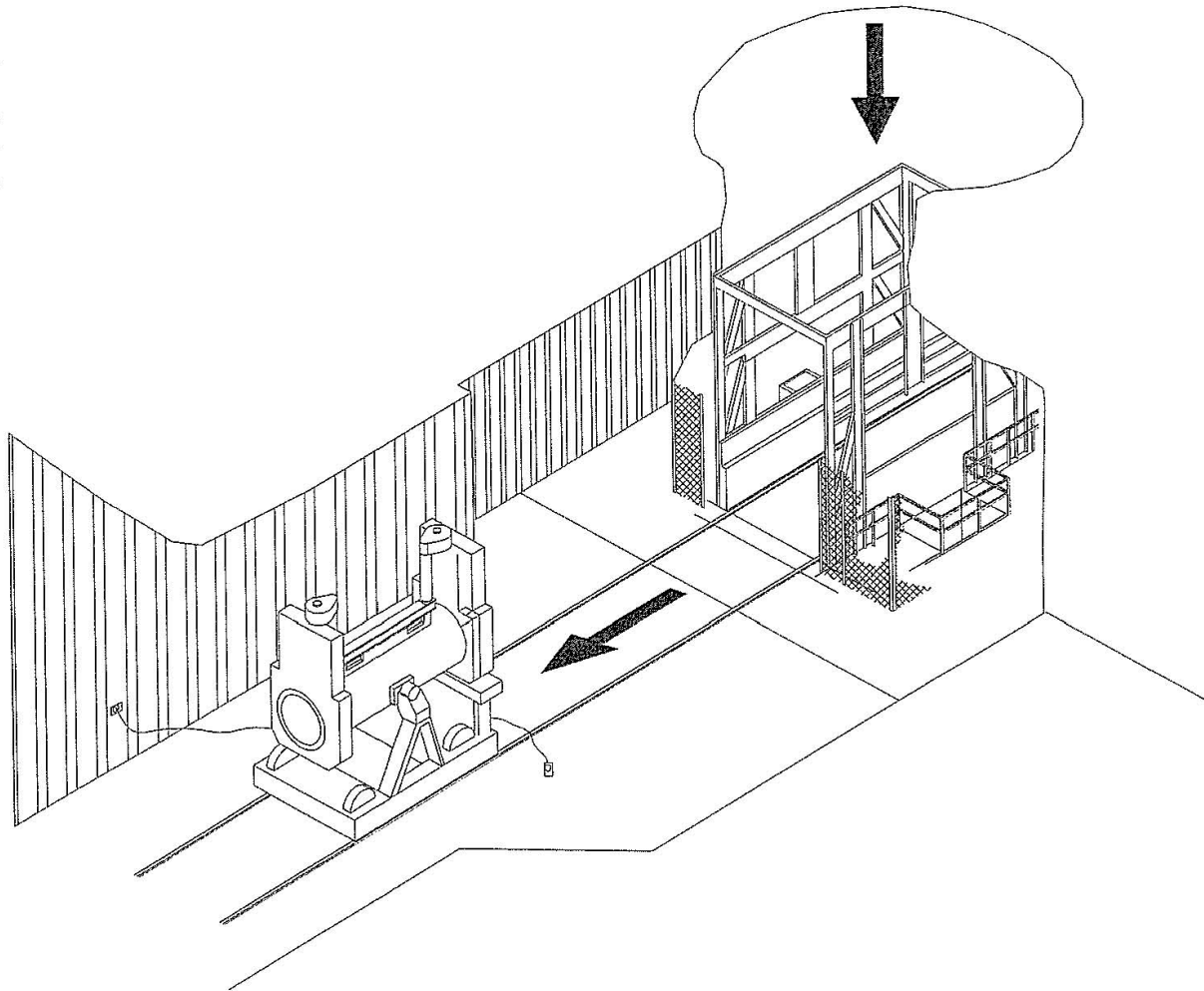
**Figure A2-14**  
**Facility Cask Transfer Car (Side View)**



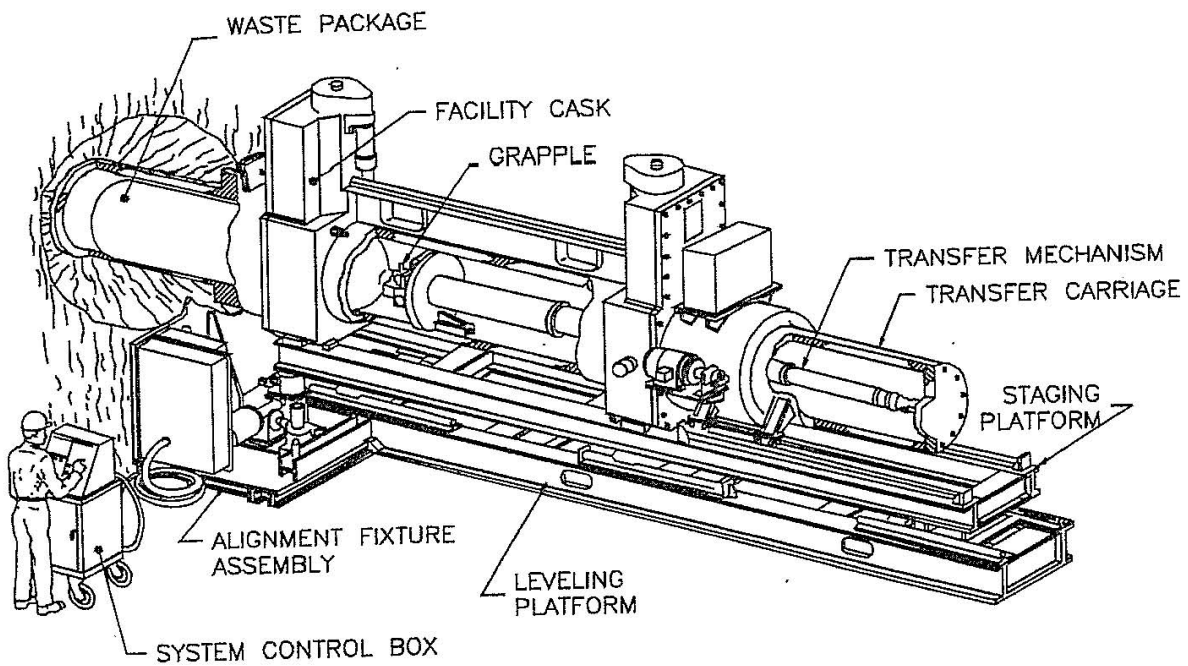
**Figure A2-15**  
**Typical Emplacement Equipment**



**Figure A2-15a**  
**Typical Emplacement Equipment**

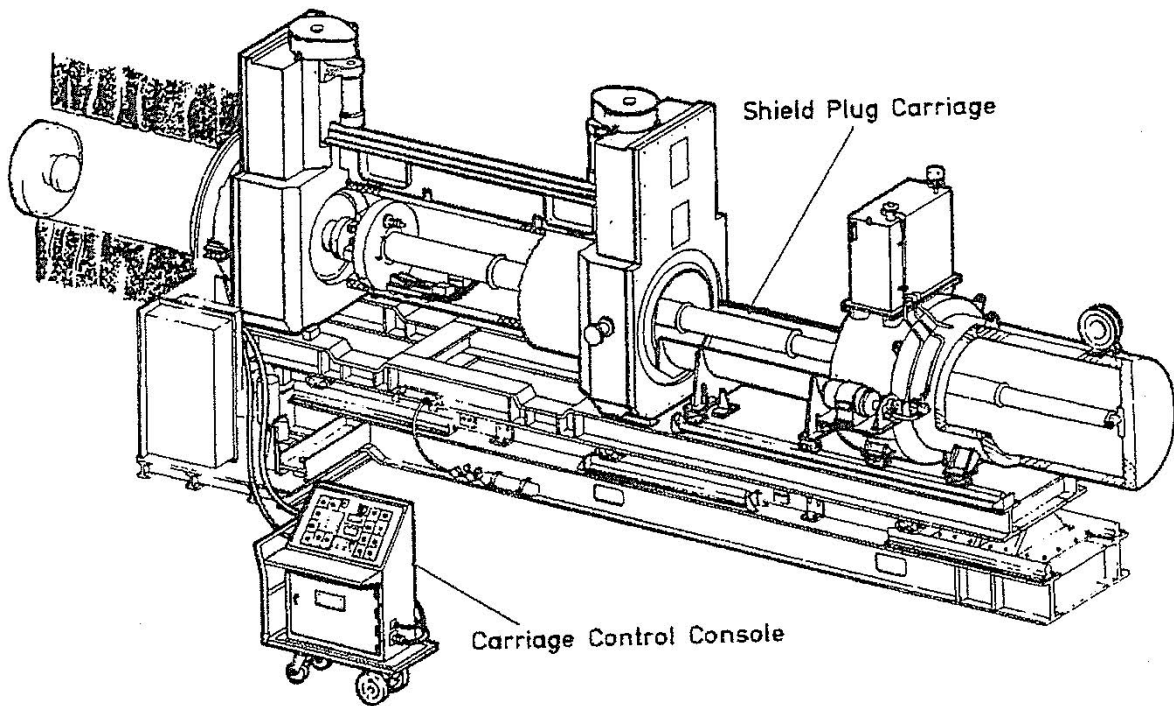


**Figure A2-16**  
**RH TRU Waste Facility Cask Unloading from Waste Shaft Conveyance**



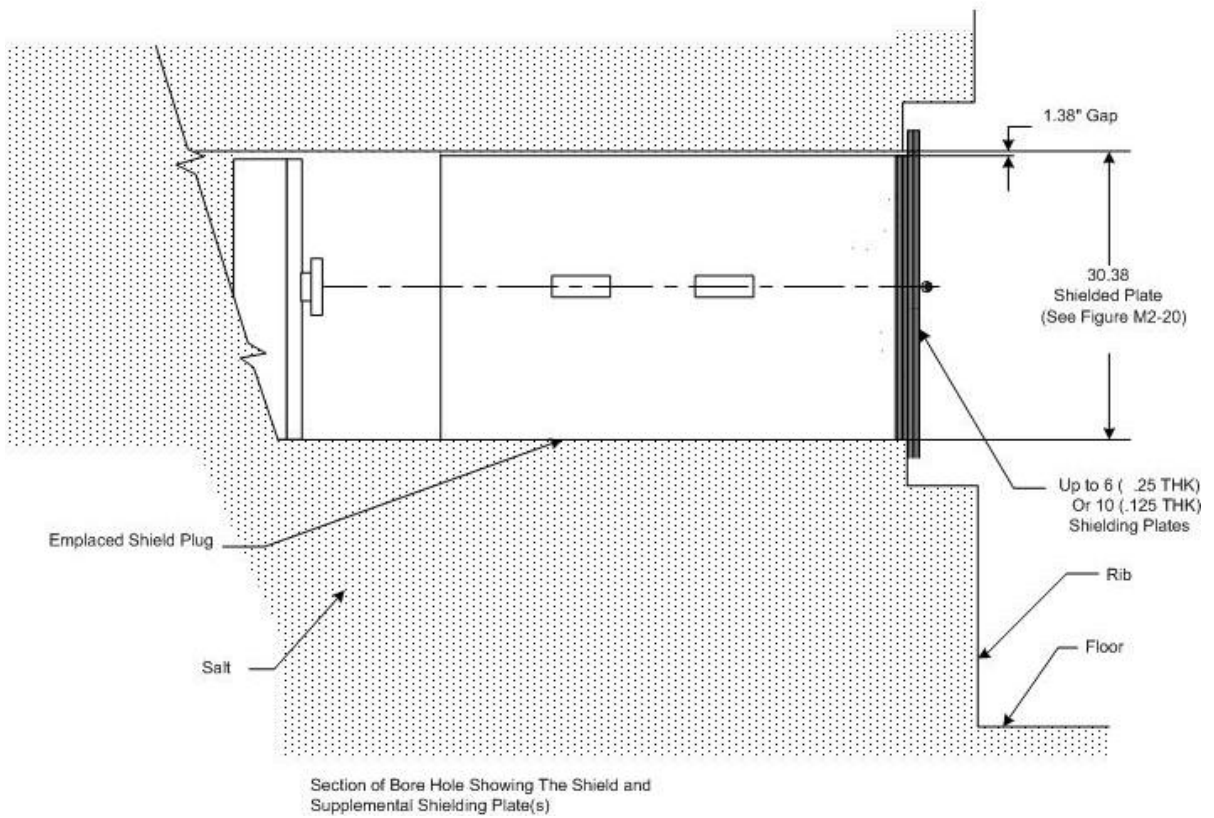
**Figure A2-17**  
**Facility Cask Installed on the Typical Emplacement Equipment**

FACILITY CASK AGAINST SHIELD COLLAR, TRANSFER CARRIAGE RETRACTED,  
SHIELD PLUG CARRIAGE ON STAGING PLATFORM, SHIELD PLUG BEING INSTALLED

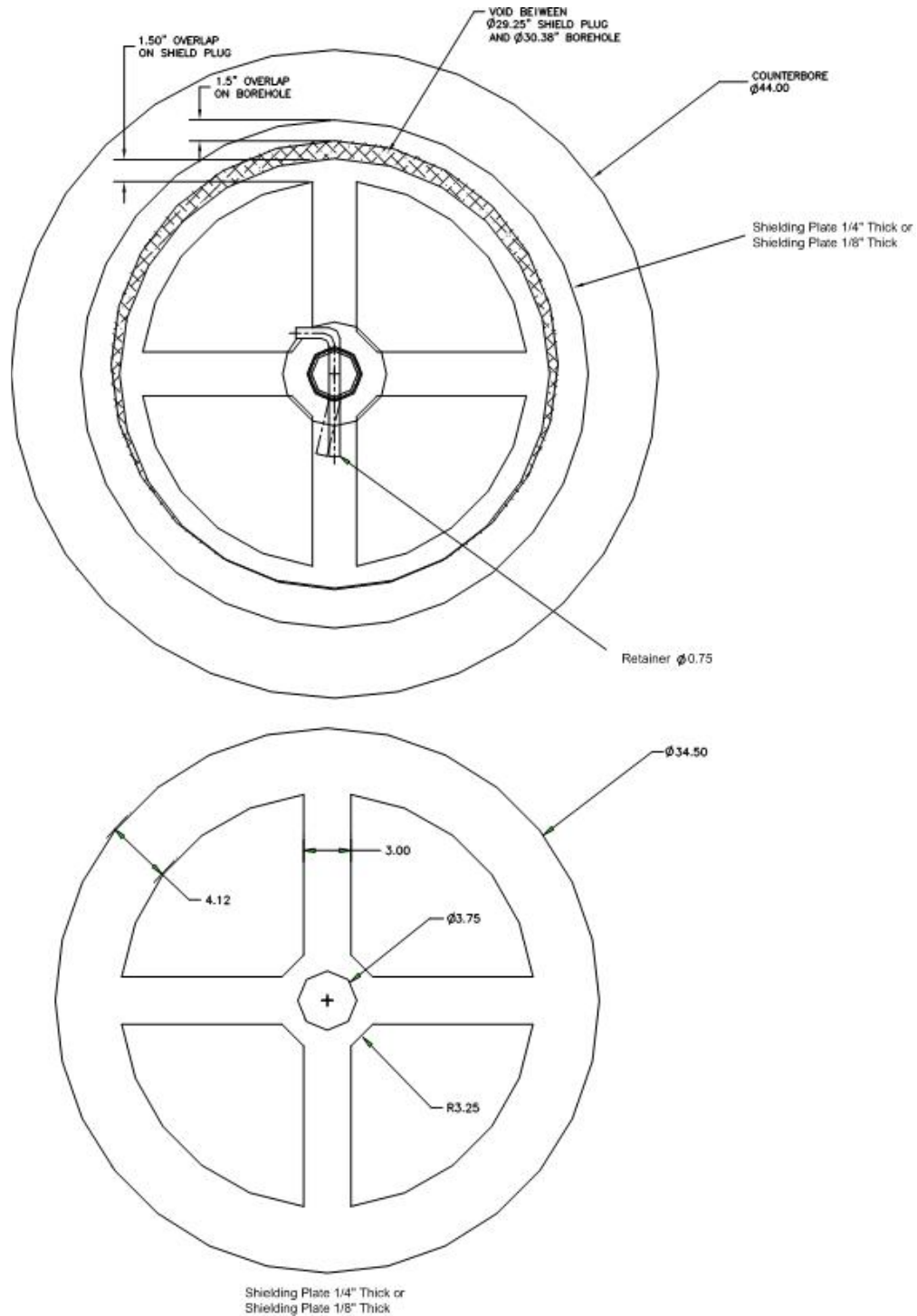


**Figure A2-18**  
**Installing Shield Plug**

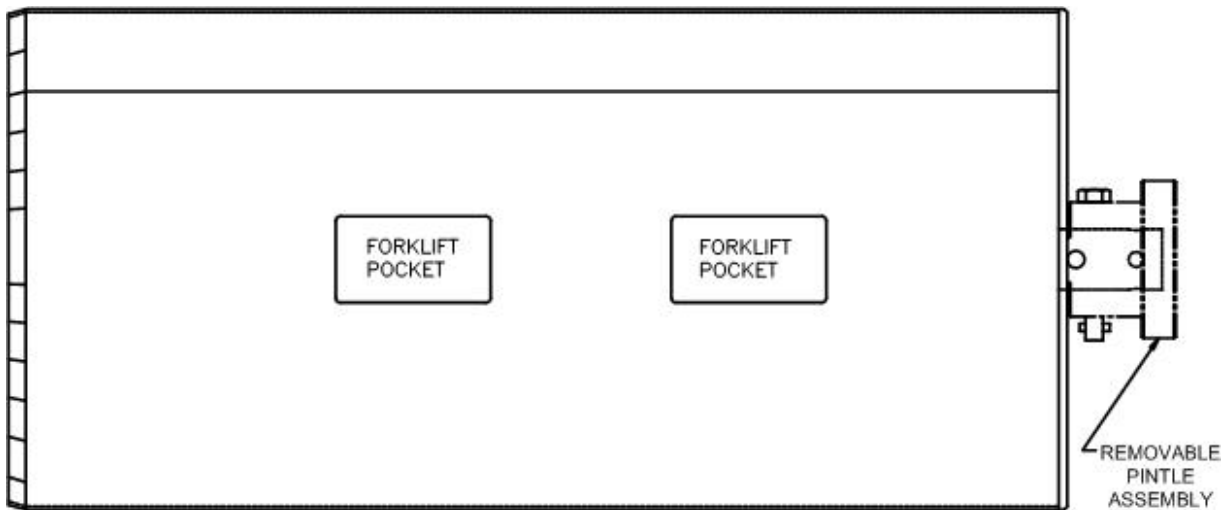




**Figure A2-19**  
**Shield Plug Supplemental Shielding Plate(s)**



**Figure A2-20**  
**Shielding Layers to Supplement RH Borehole Shield Plugs**



TYPICAL DIMENSION: APPROXIMATELY 29 INCHES DIAMETER X 61 INCHES SHIELDING LENGTH

Composition: Cylindrical steel shell filled with concrete  
Weight: Approximately 3750 pounds

**Figure A2-21**  
**Shield Plug Configuration**