

**CONOCOPHILLIPS COMPANY
EAST VACUUM/LIQUIDS RECOVERY PLANT
Title V Modification and Renewal Application
Permit P092**



**PREPARED FOR:
JIM DOBSON
CONOCOPHILLIPS COMPANY
December 2020**

EAST VACUUM/LIQUIDS RECOVERY PLANT

Title V Modification and Renewal Application

Table of Contents

Tab 1	UA1 Form - Company and Facility Information
Tab 2	UA2 Form - Application Tables
Tab 3	Section 3 - Application Summary
Tab 4	Section 4 - Process Flow Sheet
Tab 5	Section 5 - Plot Plan Drawn To Scale
Tab 6	Section 6 - All Calculations
Tab 7	Section 7 - Information Used To Determine Emissions
Tab 8	Section 8 - Map(s)
Tab 9	Section 9 - Proof of Public Notice
Tab 10	Section 10 - Written Description of the Routine Operations of the Facility
Tab 11	Section 11 -Source Determination
Tab 12	Section 12 - PSD Applicability Determination for All Sources
Tab 13	Section 13 - Determination of State & Federal Air Quality Regulations
Tab 14	Section 14 - Operational Plan to Mitigate Emissions
Tab 15	Section 15 - Alternative Operating Scenarios
Tab 16	Section 16 - Air Dispersion Modeling
Tab 17	Section 17 - Compliance Test History
Tab 18	Section 18 - Addendum for Streamline Applications (Not Applicable)
Tab 19	Section 19 - Requirements for Title V Program
Tab 20	Section 20 - Other Relevant Information
Tab 21	Section 21 - Addendum for Landfill Applications (Not Applicable)
Tab 22	Section 22 - Certification

Tab 1

UA1 Form - Company and Facility Information

<p>Application To:</p> <p>New Mexico Environment Department Air Quality Bureau Permits Section 525 Camino de los Marquez, Suite 1 Santa Fe, New Mexico, 87505</p> <p>Phone: (505) 476-4300 Fax: (505) 476-4375 www.env.nm.gov/aqb</p>		<p>For Department use only:</p> <p>AIRS No.:</p>
--	--	--

Universal Air Quality Permit Application

Use this application for NOI, NSR, or Title V sources.

Use this application for: the initial application, modifications, technical revisions, and renewals. For technical revisions, complete Sections, 1-A, 1-B, 2-E, 3, 9 and any other sections that are relevant to the requested action; coordination with the Air Quality Bureau permit staff prior to submittal is encouraged to clarify submittal requirements and to determine if more or less than these sections of the application are needed. Use this application for streamline permits as well. See Section 1-I for submittal instructions for other permits.

This application is submitted as (check all that apply): Request for a No Permit Required Determination (no fee) **Updating** an application currently under NMED review. Include this page and all pages that are being updated (no fee required).
 Construction Status: Not Constructed Existing Permitted (or NOI) Facility Existing Non-permitted (or NOI) Facility
 Minor Source: a NOI 20.2.73 NMAC 20.2.72 NMAC application or revision 20.2.72.300 NMAC Streamline application
 Title V Source: Title V (new) Title V renewal TV minor mod. TV significant mod. TV Acid Rain: New Renewal
 PSD Major Source: PSD major source (new) minor modification to a PSD source a PSD major modification

Acknowledgements:

I acknowledge that a pre-application meeting is available to me upon request. Title V Operating, Title IV Acid Rain, and NPR applications have no fees.

\$500 NSR application Filing Fee enclosed **OR** The full permit fee associated with 10 fee points (required w/ streamline applications).

Check No.: _____ in the amount of \$ _____

I acknowledge the required submittal format for the hard copy application is printed double sided 'head-to-toe', 2-hole punched (except the Sect. 2 landscape tables is printed 'head-to-head'), numbered tab separators. Incl. a copy of the check on a separate page.

This facility qualifies to receive assistance from the Small Business Environmental Assistance program (SBEAP) and qualifies for 50% of the normal application and permit fees. Enclosed is a check for 50% of the normal application fee which will be verified with the Small Business Certification Form for your company.

This facility qualifies to receive assistance from the Small Business Environmental Assistance Program (SBEAP) but does not qualify for 50% of the normal application and permit fees. To see if you qualify for SBEAP assistance and for the small business certification form go to https://www.env.nm.gov/aqb/sbap/small_business_criteria.html).

Citation: Please provide the **low level citation** under which this application is being submitted: **20.2.70.404.C.1.a and 20.2.70.201.A.2 NMAC** (e.g. application for a new minor source would be 20.2.72.200.A NMAC, one example for a Technical Permit Revision is 20.2.72.219.B.1.b NMAC, a Title V acid rain application would be: 20.2.70.200.C NMAC)

Section 1 – Facility Information

Section 1-A: Company Information

		AI # if known (see 1 st 3 to 5 #s of permit IDEA ID No.): 638	Updating Permit/NOI #: P-092
1	Facility Name: East Vacuum Liquids Recovery / CO ₂ Plant	Plant primary SIC Code (4 digits): 1311	
		Plant NAIC code (6 digits): 211120	
a	Facility Street Address (If no facility street address, provide directions from a prominent landmark): See Section 1-D.4		
2	Plant Operator Company Name: ConocoPhillips Company	Phone/Fax: (832) 486-2000	
a	Plant Operator Address: 935 N. Eldridge Parkway; EC3; Houston, TX 77079		
b	Plant Operator's New Mexico Corporate ID or Tax ID: 02181990004		

3	Plant Owner(s) name(s): ConocoPhillips Company	Phone/Fax: (832) 486-2000
a	Plant Owner(s) Mailing Address(s): 935 N. Eldridge Parkway; EC3; Houston, TX 77079	
4	Bill To (Company): ConocoPhillips Company	Phone/Fax: (832) 486-2614
a	Mailing Address: 935 N. Eldridge Parkway; SP2-12-12W184; Houston, TX 77079	E-mail: myke.k.lane@conocophillips.com
5	<input type="checkbox"/> Preparer: <input checked="" type="checkbox"/> Consultant: Evan Tullos - PEI	Phone/Fax: (865) 850-2007
a	Mailing Address: 5 Cardinal Court; Edwardsville, IL 62025	E-mail: etullos@pei-tx.com
6	Plant Operator Contact: Chris Wood	Phone/Fax: (575) 391-3106
a	Mailing Address: 29 Vacuum Complex Lane; Lovington, NM 88260	E-mail: chris.wood@conocophillips.com
7	Air Permit Contact: Myke Lane	Title: Senior Environmental Coordinator
a	E-mail: myke.k.lane@conocophillips.com	Phone/Fax: (832) 486-2614
b	Mailing Address: 935 N. Eldridge Parkway; SP2-12-12W184; Houston, TX 77079	
c	The designated Air permit Contact will receive all official correspondence (i.e. letters, permits) from the Air Quality Bureau.	

Section 1-B: Current Facility Status

1.a	Has this facility already been constructed? <input checked="" type="checkbox"/> Yes <input type="checkbox"/> No	1.b If yes to question 1.a, is it currently operating in New Mexico? <input checked="" type="checkbox"/> Yes <input type="checkbox"/> No
2	If yes to question 1.a, was the existing facility subject to a Notice of Intent (NOI) (20.2.73 NMAC) before submittal of this application? <input type="checkbox"/> Yes <input checked="" type="checkbox"/> No	If yes to question 1.a, was the existing facility subject to a construction permit (20.2.72 NMAC) before submittal of this application? <input checked="" type="checkbox"/> Yes <input type="checkbox"/> No
3	Is the facility currently shut down? <input type="checkbox"/> Yes <input checked="" type="checkbox"/> No	If yes, give month and year of shut down (MM/YY):
4	Was this facility constructed before 8/31/1972 and continuously operated since 1972? <input type="checkbox"/> Yes <input checked="" type="checkbox"/> No	
5	If Yes to question 3, has this facility been modified (see 20.2.72.7.P NMAC) or the capacity increased since 8/31/1972? <input type="checkbox"/> Yes <input type="checkbox"/> No <input checked="" type="checkbox"/> N/A	
6	Does this facility have a Title V operating permit (20.2.70 NMAC)? <input checked="" type="checkbox"/> Yes <input type="checkbox"/> No	If yes, the permit No. is: P-092
7	Has this facility been issued a No Permit Required (NPR)? <input type="checkbox"/> Yes <input checked="" type="checkbox"/> No	If yes, the NPR No. is:
8	Has this facility been issued a Notice of Intent (NOI)? <input type="checkbox"/> Yes <input checked="" type="checkbox"/> No	If yes, the NOI No. is:
9	Does this facility have a construction permit (20.2.72 NMAC)? <input checked="" type="checkbox"/> Yes <input type="checkbox"/> No	If yes, the permit No. is: 0218
10	Is this facility registered under a General permit (GCP-1, GCP-2, etc.)? <input type="checkbox"/> Yes <input checked="" type="checkbox"/> No	If yes, the register No. is:

Section 1-C: Facility Input Capacity & Production Rate

1	What is the facility's maximum input capacity, specify units (reference here and list capacities in Section 20, if more room is required)			
a	Current	Hourly: 1.875mmscf	Daily: 45 mmscf	Annually: 16,425 mmscf
b	Proposed	Hourly: 1.875mmscf	Daily: 45 mmscf	Annually: 16,425 mmscf
2	What is the facility's maximum production rate, specify units (reference here and list capacities in Section 20, if more room is required)			
a	Current	Hourly: 1.875mmscf	Daily: 45 mmscf	Annually: 16,425 mmscf
b	Proposed	Hourly: 1.875mmscf	Daily: 45 mmscf	Annually: 16,425 mmscf

Section 1-D: Facility Location Information

1	Section: 33	Range: 35E	Township: 17S	County: Lea	Elevation (ft): 3948
2	UTM Zone: <input type="checkbox"/> 12 or <input checked="" type="checkbox"/> 13			Datum: <input checked="" type="checkbox"/> NAD 27 <input type="checkbox"/> NAD 83 <input type="checkbox"/> WGS 84	
a	UTM E (in meters, to nearest 10 meters): 644460			UTM N (in meters, to nearest 10 meters): 3629590	
b	AND Latitude (deg., min., sec.): 32° 47' 41"			Longitude (deg., min., sec.): -103° 27' 26"	
3	Name and zip code of nearest New Mexico town: Buckeye, 88260				
4	Detailed Driving Instructions from nearest NM town (attach a road map if necessary): From Hwy. 283 and CR 50 in Buckeye, travel east on CR 50 for 2.9 miles. Turn right on Vacuum Complex Lane to facility.				
5	The facility is 2.7 (distance) miles east (direction) of Buckeye, NM (nearest town).				
6	Status of land at facility (check one): <input type="checkbox"/> Private <input type="checkbox"/> Indian/Pueblo <input checked="" type="checkbox"/> Federal BLM <input type="checkbox"/> Federal Forest Service <input type="checkbox"/> Other (specify)				
7	List all municipalities, Indian tribes, and counties within a ten (10) mile radius (20.2.72.203.B.2 NMAC) of the property on which the facility is proposed to be constructed or operated: Hobbs, Lovington, Lea				
8	20.2.72 NMAC applications only: Will the property on which the facility is proposed to be constructed or operated be closer than 50 km (31 miles) to other states, Bernalillo County, or a Class I area (see www.nmenv.state.nm.us/aqb/modeling/class1areas.html)? <input type="checkbox"/> Yes <input checked="" type="checkbox"/> No (20.2.72.206.A.7 NMAC) If yes, list all with corresponding distances in kilometers:				
9	Name nearest Class I area: Carlsbad Caverns National Park				
10	Shortest distance (in km) from facility boundary to the boundary of the nearest Class I area (to the nearest 10 meters): 107.40				
11	Distance (meters) from the perimeter of the Area of Operations (AO is defined as the plant site inclusive of all disturbed lands, including mining overburden removal areas) to nearest residence, school or occupied structure: 321.9				
12	Method(s) used to delineate the Restricted Area: None "Restricted Area" is an area to which public entry is effectively precluded. Effective barriers include continuous fencing, continuous walls, or other continuous barriers approved by the Department, such as rugged physical terrain with steep grade that would require special equipment to traverse. If a large property is completely enclosed by fencing, a restricted area within the property may be identified with signage only. Public roads cannot be part of a Restricted Area.				
13	Does the owner/operator intend to operate this source as a portable stationary source as defined in 20.2.72.7.X NMAC? <input type="checkbox"/> Yes <input checked="" type="checkbox"/> No A portable stationary source is not a mobile source, such as an automobile, but a source that can be installed permanently at one location or that can be re-installed at various locations, such as a hot mix asphalt plant that is moved to different job sites.				
14	Will this facility operate in conjunction with other air regulated parties on the same property? <input checked="" type="checkbox"/> No <input type="checkbox"/> Yes If yes, what is the name and permit number (if known) of the other facility?				

Section 1-E: Proposed Operating Schedule (The 1-E.1 & 1-E.2 operating schedules may become conditions in the permit.)

1	Facility maximum operating ($\frac{\text{hours}}{\text{day}}$): 24	($\frac{\text{days}}{\text{week}}$): 7	($\frac{\text{weeks}}{\text{year}}$): 52	($\frac{\text{hours}}{\text{year}}$): 8760
2	Facility's maximum daily operating schedule (if less than 24 $\frac{\text{hours}}{\text{day}}$)? Start:		<input type="checkbox"/> AM <input type="checkbox"/> PM	End: <input type="checkbox"/> AM <input type="checkbox"/> PM
3	Month and year of anticipated start of construction: N/A			
4	Month and year of anticipated construction completion: N/A			
5	Month and year of anticipated startup of new or modified facility: N/A			
6	Will this facility operate at this site for more than one year? <input checked="" type="checkbox"/> Yes <input type="checkbox"/> No			

Section 1-F: Other Facility Information

1	Are there any current Notice of Violations (NOV), compliance orders, or any other compliance or enforcement issues related to this facility? <input type="checkbox"/> Yes <input checked="" type="checkbox"/> No If yes, specify:
---	---

a	If yes, NOV date or description of issue:	NOV Tracking No:
b	Is this application in response to any issue listed in 1-F, 1 or 1a above? <input type="checkbox"/> Yes <input type="checkbox"/> No If Yes, provide the 1c & 1d info below:	
c	Document Title:	Date: Requirement # (or page # and paragraph #):
d	Provide the required text to be inserted in this permit:	
2	Is air quality dispersion modeling or modeling waiver being submitted with this application? <input type="checkbox"/> Yes <input checked="" type="checkbox"/> No	
3	Does this facility require an "Air Toxics" permit under 20.2.72.400 NMAC & 20.2.72.502, Tables A and/or B? <input type="checkbox"/> Yes <input checked="" type="checkbox"/> No	
4	Will this facility be a source of federal Hazardous Air Pollutants (HAP)? <input checked="" type="checkbox"/> Yes <input type="checkbox"/> No	
a	If Yes, what type of source? <input type="checkbox"/> Major (<input type="checkbox"/> ≥10 tpy of any single HAP OR <input type="checkbox"/> ≥25 tpy of any combination of HAPS) OR <input checked="" type="checkbox"/> Minor (<input checked="" type="checkbox"/> <10 tpy of any single HAP AND <input checked="" type="checkbox"/> <25 tpy of any combination of HAPS)	
5	Is any unit exempt under 20.2.72.202.B.3 NMAC? <input type="checkbox"/> Yes <input checked="" type="checkbox"/> No	
a	If yes, include the name of company providing commercial electric power to the facility: _____ Commercial power is purchased from a commercial utility company, which specifically does not include power generated on site for the sole purpose of the user.	

Section 1-G: Streamline Application

(This section applies to 20.2.72.300 NMAC Streamline applications only)

1	<input type="checkbox"/> I have filled out Section 18, "Addendum for Streamline Applications." <input checked="" type="checkbox"/> N/A (This is not a Streamline application.)
---	--

Section 1-H: Current Title V Information - Required for all applications from TV Sources

(Title V-source required information for all applications submitted pursuant to 20.2.72 NMAC (Minor Construction Permits), or 20.2.74/20.2.79 NMAC (Major PSD/NNSR applications), and/or 20.2.70 NMAC (Title V))

1	Responsible Official (R.O.) (20.2.70.300.D.2 NMAC): Stephen Bradley	Phone: (281) 293-1000
a	R.O. Title: Senior Operations Manager	R.O. e-mail: stephen.bradley@conocophillips.com
b	R. O. Address: P.O. Box 2197; Houston, TX 77252-2197	
2	Alternate Responsible Official (20.2.70.300.D.2 NMAC):	Phone:
a	A. R.O. Title:	A. R.O. e-mail:
b	A. R. O. Address:	
3	Company's Corporate or Partnership Relationship to any other Air Quality Permittee (List the names of any companies that have operating (20.2.70 NMAC) permits and with whom the applicant for this permit has a corporate or partnership relationship): Not applicable	
4	Name of Parent Company ("Parent Company" means the primary name of the organization that owns the company to be permitted wholly or in part.): ConocoPhillips Company	
a	Address of Parent Company: 935 N. Eldridge Parkway; Houston, TX 77079	
5	Names of Subsidiary Companies ("Subsidiary Companies" means organizations, branches, divisions or subsidiaries, which are owned, wholly or in part, by the company to be permitted.):	
6	Telephone numbers & names of the owners' agents and site contacts familiar with plant operations: Kile Wright (575) 391-5595	
7	Affected Programs to include Other States, local air pollution control programs (i.e. Bernalillo) and Indian tribes: Will the property on which the facility is proposed to be constructed or operated be closer than 80 km (50 miles) from other states, local pollution control programs, and Indian tribes and pueblos (20.2.70.402.A.2 and 20.2.70.7.B)? If yes, state which ones and provide the distances in kilometers: Bernalillo – No; Tribes – No; States – Yes, Texas 60 km	

Section 1-I – Submittal Requirements

Each 20.2.73 NMAC (NOI), a 20.2.70 NMAC (Title V), a 20.2.72 NMAC (NSR minor source), or 20.2.74 NMAC (PSD) application package shall consist of the following:

Hard Copy Submittal Requirements:

- 1) One hard copy **original signed and notarized application package printed double sided ‘head-to-toe’ 2-hole punched** as we bind the document on top, not on the side; except Section 2 (landscape tables), which should be **head-to-head**. Please use **numbered tab separators** in the hard copy submittal(s) as this facilitates the review process. For NOI submittals only, hard copies of UA1, Tables 2A, 2D & 2F, Section 3 and the signed Certification Page are required. **Please include a copy of the check on a separate page.**
- 2) If the application is for a minor NSR, PSD, NNSR, or Title V application, include one working hard **copy** for Department use. This **copy** should be printed in book form, 3-hole punched, and **must be double sided**. Note that this is in addition to the head-to-toe 2-hole punched copy required in 1) above. Minor NSR Technical Permit revisions (20.2.72.219.B NMAC) only need to fill out Sections 1-A, 1-B, 3, and should fill out those portions of other Section(s) relevant to the technical permit revision. TV Minor Modifications need only fill out Sections 1-A, 1-B, 1-H, 3, and those portions of other Section(s) relevant to the minor modification. NMED may require additional portions of the application to be submitted, as needed.
- 3) The entire NOI or Permit application package, including the full modeling study, should be submitted electronically. Electronic files for applications for NOIs, any type of General Construction Permit (GCP), or technical revisions to NSRs must be submitted with compact disk (CD) or digital versatile disc (DVD). For these permit application submittals, **two CD** copies are required (in sleeves, not crystal cases, please), with additional CD copies as specified below. NOI applications require only a **single CD** submittal. Electronic files for other New Source Review (construction) permits/permit modifications or Title V permits/permit modifications can be submitted on CD/DVD or sent through AQB’s secure file transfer service.

Electronic files sent by (check one):

CD/DVD attached to paper application

secure electronic transfer. Air Permit Contact Name Evan Tullos

Email etullos@pei-tx.com

Phone number (865) 850-2007

a. If the file transfer service is chosen by the applicant, after receipt of the application, the Bureau will email the applicant with instructions for submitting the electronic files through a secure file transfer service. Submission of the electronic files through the file transfer service needs to be completed within 3 business days after the invitation is received, so the applicant should ensure that the files are ready when sending the hard copy of the application. The applicant will not need a password to complete the transfer. **Do not use the file transfer service for NOIs, any type of GCP, or technical revisions to NSR permits.**

- 4) Optionally, the applicant may submit the files with the application on compact disk (CD) or digital versatile disc (DVD) following the instructions above and the instructions in 5 for applications subject to PSD review.
- 5) If **air dispersion modeling** is required by the application type, include the **NMED Modeling Waiver** and/or electronic air dispersion modeling report, input, and output files. The dispersion modeling **summary report only** should be submitted as hard copy(ies) unless otherwise indicated by the Bureau.
- 6) If the applicant submits the electronic files on CD and the application is subject to PSD review under 20.2.74 NMAC (PSD) or NNSR under 20.2.79 NMC include,
 - a. one additional CD copy for US EPA,
 - b. one additional CD copy for each federal land manager affected (NPS, USFS, FWS, USDI) and,
 - c. one additional CD copy for each affected regulatory agency other than the Air Quality Bureau.

If the application is submitted electronically through the secure file transfer service, these extra CDs do not need to be submitted.

Electronic Submittal Requirements [in addition to the required hard copy(ies)]:

- 1) All required electronic documents shall be submitted as 2 separate CDs or submitted through the AQB secure file transfer service. Submit a single PDF document of the entire application as submitted and the individual documents comprising the application.
- 2) The documents should also be submitted in Microsoft Office compatible file format (Word, Excel, etc.) allowing us to access the text and formulas in the documents (copy & paste). Any documents that cannot be submitted in a Microsoft Office compatible format shall be saved as a PDF file from within the electronic document that created the file. If you are unable to provide

Microsoft office compatible electronic files or internally generated PDF files of files (items that were not created electronically: i.e. brochures, maps, graphics, etc.), submit these items in hard copy format. We must be able to review the formulas and inputs that calculated the emissions.

- 3) It is preferred that this application form be submitted as 4 electronic files (**3 MSWord docs**: Universal Application section 1 [UA1], Universal Application section 3-19 [UA3], and Universal Application 4, the modeling report [UA4]) and **1 Excel file** of the tables (Universal Application section 2 [UA2]). Please include as many of the 3-19 Sections as practical in a single MS Word electronic document. Create separate electronic file(s) if a single file becomes too large or if portions must be saved in a file format other than MS Word.
- 4) The **electronic file names** shall be a maximum of 25 characters long (including spaces, if any). The format of the electronic Universal Application shall be in the format: "A-3423-FacilityName". The "A" distinguishes the file as an application submittal, as opposed to other documents the Department itself puts into the database. Thus, all electronic application submittals should begin with "A-". Modifications to existing facilities should use the **core permit number** (i.e. '3423') the Department assigned to the facility as the next 4 digits. Use 'XXXX' for new facility applications. The format of any separate electronic submittals (additional submittals such as non-Word attachments, re-submittals, application updates) and Section document shall be in the format: "A-3423-9-description", where "9" stands for the **section #** (in this case Section 9-Public Notice). Please refrain, as much as possible, from submitting any scanned documents as this file format is extremely large, which uses up too much storage capacity in our database. Please take the time to fill out the **header information** throughout all submittals as this will identify any loose pages, including the Application Date (date submitted) & Revision number (0 for original, 1, 2, etc.; which will help keep track of subsequent partial update(s) to the original submittal. Do not use special symbols (#, @, etc.) in file names. The footer information should not be modified by the applicant.

Table of Contents

Section 1:	General Facility Information
Section 2:	Tables
Section 3:	Application Summary
Section 4:	Process Flow Sheet
Section 5:	Plot Plan Drawn to Scale
Section 6:	All Calculations
Section 7:	Information Used to Determine Emissions
Section 8:	Map(s)
Section 9:	Proof of Public Notice
Section 10:	Written Description of the Routine Operations of the Facility
Section 11:	Source Determination
Section 12:	PSD Applicability Determination for All Sources & Special Requirements for a PSD Application
Section 13:	Discussion Demonstrating Compliance with Each Applicable State & Federal Regulation
Section 14:	Operational Plan to Mitigate Emissions
Section 15:	Alternative Operating Scenarios
Section 16:	Air Dispersion Modeling
Section 17:	Compliance Test History
Section 18:	Addendum for Streamline Applications (streamline applications only)
Section 19:	Requirements for the Title V (20.2.70 NMAC) Program (Title V applications only)
Section 20:	Other Relevant Information
Section 21:	Addendum for Landfill Applications
Section 22:	Certification Page

Tab 2
UA2 Form - Application Tables

Table 2-A: Regulated Emission Sources

Unit and stack numbering must correspond throughout the application package. If applying for a NOI under 20.2.73 NMAC, equipment exemptions under 2.72.202 NMAC do not apply.

Unit Number ¹	Source Description	Make	Model #	Serial #	Manufacturer's Rated Capacity ³ (Specify Units)	Requested Permitted Capacity ³ (Specify Units)	Date of Manufacture ²	Controlled by Unit #	Source Classification Code (SCC)	For Each Piece of Equipment, Check One	RICE Ignition Type (CI, SI, 4SLB, 4SRB, 2SLB) ⁴	Replacing Unit No.
							Date of Construction/Reconstruction ²	Emissions vented to Stack #				
1	Natural Gas Fired Turbine	Solar Saturn	T1202	0646513	1160 hp	1160 hp	1980	N/A	20200201	<input checked="" type="checkbox"/> Existing (unchanged) <input type="checkbox"/> To be Removed <input type="checkbox"/> New/Additional <input type="checkbox"/> Replacement Unit <input type="checkbox"/> To Be Modified <input type="checkbox"/> To be Replaced	N/A	N/A
							2007	1				
2	Natural Gas Fired Turbine	Solar Saturn	T1202	10109	1160 hp	1160 hp	1980	N/A	20200201	<input checked="" type="checkbox"/> Existing (unchanged) <input type="checkbox"/> To be Removed <input type="checkbox"/> New/Additional <input type="checkbox"/> Replacement Unit <input type="checkbox"/> To Be Modified <input type="checkbox"/> To be Replaced	N/A	N/A
							2007	2				
3	Natural Gas Fired Turbine	Solar Saturn	T1202	30137-2	1160 hp	1160 hp	1980	N/A	20200201	<input checked="" type="checkbox"/> Existing (unchanged) <input type="checkbox"/> To be Removed <input type="checkbox"/> New/Additional <input type="checkbox"/> Replacement Unit <input type="checkbox"/> To Be Modified <input type="checkbox"/> To be Replaced	N/A	N/A
							2009	3				
4	Natural Gas Fired Turbine	Solar Saturn	T1202	0242S21	1160 hp	1160 hp	1980	N/A	20200201	<input checked="" type="checkbox"/> Existing (unchanged) <input type="checkbox"/> To be Removed <input type="checkbox"/> New/Additional <input type="checkbox"/> Replacement Unit <input type="checkbox"/> To Be Modified <input type="checkbox"/> To be Replaced	N/A	N/A
							2009	3				
7	Hot Oil Heater	National Airoil Company	N/A	J91512	15 MMbtu/hr	15 MMbtu/hr	1991	N/A	31000404	<input checked="" type="checkbox"/> Existing (unchanged) <input type="checkbox"/> To be Removed <input type="checkbox"/> New/Additional <input type="checkbox"/> Replacement Unit <input type="checkbox"/> To Be Modified <input type="checkbox"/> To be Replaced	N/A	N/A
							1991	7				
16	4 SRB RICE	Waukesha	L7042 GU	WPI658	636 hp	636 hp	1992	16	20200202	<input checked="" type="checkbox"/> Existing (unchanged) <input type="checkbox"/> To be Removed <input type="checkbox"/> New/Additional <input type="checkbox"/> Replacement Unit <input type="checkbox"/> To Be Modified <input type="checkbox"/> To be Replaced	4SRB	N/A
							1992	16				
17	4 SRB RICE	Waukesha	L7042 GU	339381	636 hp	636 hp	1992	17	20200202	<input checked="" type="checkbox"/> Existing (unchanged) <input type="checkbox"/> To be Removed <input type="checkbox"/> New/Additional <input type="checkbox"/> Replacement Unit <input type="checkbox"/> To Be Modified <input type="checkbox"/> To be Replaced	4SRB	N/A
							1992	17				
19	Process Flare	Flare King	N/A	N/A	5 mmscfd	5 mmscfd	1997	N/A	31000205	<input type="checkbox"/> Existing (unchanged) <input type="checkbox"/> To be Removed <input type="checkbox"/> New/Additional <input type="checkbox"/> Replacement Unit <input checked="" type="checkbox"/> To Be Modified <input type="checkbox"/> To be Replaced	N/A	N/A
							1997	19				
T-11	Skim Tank	J&J Steel & Supply Co.	N/A	9157	10,000 bbl	10,000 bbl	1979	20/21 ³	40400311	<input checked="" type="checkbox"/> Existing (unchanged) <input type="checkbox"/> To be Removed <input type="checkbox"/> New/Additional <input type="checkbox"/> Replacement Unit <input type="checkbox"/> To Be Modified <input type="checkbox"/> To be Replaced	N/A	N/A
							1979	20/21 ³				
T-12	Overflow Tank	J&J Steel & Supply Co.	N/A	9160	10,000 bbl	10,000 bbl	1979	20/21 ³	40400311	<input checked="" type="checkbox"/> Existing (unchanged) <input type="checkbox"/> To be Removed <input type="checkbox"/> New/Additional <input type="checkbox"/> Replacement Unit <input type="checkbox"/> To Be Modified <input type="checkbox"/> To be Replaced	N/A	N/A
							1979	20/21 ³				
T-13	Sales Tank	J&J Steel & Supply Co.	N/A	9156	5,000 bbl	5,000 bbl	1979	20/21 ³	40400311	<input checked="" type="checkbox"/> Existing (unchanged) <input type="checkbox"/> To be Removed <input type="checkbox"/> New/Additional <input type="checkbox"/> Replacement Unit <input type="checkbox"/> To Be Modified <input type="checkbox"/> To be Replaced	N/A	N/A
							1979	20/21 ³				
T-14	Surge Tank	J&J Steel & Supply Co.	N/A	9158	10,000 bbl	10,000 bbl	1979	20/21 ³	40400311	<input checked="" type="checkbox"/> Existing (unchanged) <input type="checkbox"/> To be Removed <input type="checkbox"/> New/Additional <input type="checkbox"/> Replacement Unit <input type="checkbox"/> To Be Modified <input type="checkbox"/> To be Replaced	N/A	N/A
							1979	20/21 ³				
T-15	Produced Water Tank	J&J Steel & Supply Co.	N/A	22113266	10,000 bbl	10,000 bbl	2004	20/21 ³	40400315	<input checked="" type="checkbox"/> Existing (unchanged) <input type="checkbox"/> To be Removed <input type="checkbox"/> New/Additional <input type="checkbox"/> Replacement Unit <input type="checkbox"/> To Be Modified <input type="checkbox"/> To be Replaced	N/A	N/A
							2004	20/21 ³				
T-36	Fresh Water Tank (No emissions)	J&J Steel & Supply Co.	N/A	N/A	10,000 bbl	10,000 bbl	1980	N/A	N/A	<input checked="" type="checkbox"/> Existing (unchanged) <input type="checkbox"/> To be Removed <input type="checkbox"/> New/Additional <input type="checkbox"/> Replacement Unit <input type="checkbox"/> To Be Modified <input type="checkbox"/> To be Replaced	N/A	N/A
							1980	N/A				
T-40	Product Tank	J&J Steel & Supply Co.	N/A	N/A	1,000 bbl	1,000 bbl	2000	20/21 ³	40400315	<input type="checkbox"/> Existing (unchanged) <input checked="" type="checkbox"/> To be Removed <input type="checkbox"/> New/Additional <input type="checkbox"/> Replacement Unit <input type="checkbox"/> To Be Modified <input type="checkbox"/> To be Replaced	N/A	N/A
							2000	20/21 ³				

Unit Number ¹	Source Description	Make	Model #	Serial #	Manufacturer's Rated Capacity ³ (Specify Units)	Requested Permitted Capacity ³ (Specify Units)	Date of Manufacture ²		Controlled by Unit #	Source Classification Code (SCC)	For Each Piece of Equipment, Check One	RICE Ignition Type (CI, SI, 4SLB, 4SRB, 2SLB) ⁴	Replacing Unit No.
							Date of Construction/ Reconstruction ²	Emissions vented to Stack #					
T-41	Product Tank	J&J Steel & Supply Co.	N/A	N/A	1,000 bbl	1,000 bbl	2000	20/21 ³	40400315	<input type="checkbox"/> Existing (unchanged) <input checked="" type="checkbox"/> To be Removed <input type="checkbox"/> New/Additional <input type="checkbox"/> Replacement Unit <input type="checkbox"/> To Be Modified <input type="checkbox"/> To be Replaced	N/A	N/A	
							2000	20/21 ³					
T-42	Emergency Overflow Tank	J&J Steel & Supply Co.	N/A	22113267	15,000 bbl	15,000 bbl	2004	20/21 ³	40400311	<input checked="" type="checkbox"/> Existing (unchanged) <input type="checkbox"/> To be Removed <input type="checkbox"/> New/Additional <input type="checkbox"/> Replacement Unit <input type="checkbox"/> To Be Modified <input type="checkbox"/> To be Replaced	N/A	N/A	
							2004	20/21 ³					
FUG1	Process Fugitives	N/A	N/A	N/A	N/A	N/A	N/A	N/A	31088811	<input checked="" type="checkbox"/> Existing (unchanged) <input type="checkbox"/> To be Removed <input type="checkbox"/> New/Additional <input type="checkbox"/> Replacement Unit <input type="checkbox"/> To Be Modified <input type="checkbox"/> To be Replaced	N/A	N/A	
							N/A	N/A					
FUG2	Tank Fugitives	N/A	N/A	N/A	N/A	N/A	N/A	N/A	31088811	<input checked="" type="checkbox"/> Existing (unchanged) <input type="checkbox"/> To be Removed <input type="checkbox"/> New/Additional <input type="checkbox"/> Replacement Unit <input type="checkbox"/> To Be Modified <input type="checkbox"/> To be Replaced	N/A	N/A	
							N/A	N/A					
NGL / CO ₂	Natural Gas Liquids / Carbon Dioxide Plant	Unknown	N/A	N/A	45 MMscf/d	45 MMscf/d	N/A	N/A	31088811	<input checked="" type="checkbox"/> Existing (unchanged) <input type="checkbox"/> To be Removed <input type="checkbox"/> New/Additional <input type="checkbox"/> Replacement Unit <input type="checkbox"/> To Be Modified <input type="checkbox"/> To be Replaced	N/A	N/A	
							Jan-92	FUG1					
DEHY1	TEG Dehydrator: Still Vent and Flash Tank	Unknown	N/A	N/A	35 MMscf/d	35 MMscf/d	N/A	N/A	31000227	<input checked="" type="checkbox"/> Existing (unchanged) <input type="checkbox"/> To be Removed <input type="checkbox"/> New/Additional <input type="checkbox"/> Replacement Unit <input type="checkbox"/> To Be Modified <input type="checkbox"/> To be Replaced	N/A	N/A	
							Jan-92	DEHY1 ⁴					
20	VRU1	J&J Steel & Supply Co.	N/A	9156, 9157, 9158, 9160, 22113266	Varies	Varies	N/A	N/A	N/A	<input checked="" type="checkbox"/> Existing (unchanged) <input type="checkbox"/> To be Removed <input type="checkbox"/> New/Additional <input type="checkbox"/> Replacement Unit <input type="checkbox"/> To Be Modified <input type="checkbox"/> To be Replaced	N/A	N/A	
							3/31/2016	N/A					
21	VRU2	J&J Steel & Supply Co.	N/A	9156, 9157, 9158, 9160, 22113266	Varies	Varies	N/A	N/A	N/A	<input checked="" type="checkbox"/> Existing (unchanged) <input type="checkbox"/> To be Removed <input type="checkbox"/> New/Additional <input type="checkbox"/> Replacement Unit <input type="checkbox"/> To Be Modified <input type="checkbox"/> To be Replaced	N/A	N/A	
							3/31/2016	N/A					
22	Temporary Flare	Varies	Varies	N/A	500 Mscf/d	500 Mscf/d	2013	N/A	31000205	<input type="checkbox"/> Existing (unchanged) <input type="checkbox"/> To be Removed <input type="checkbox"/> New/Additional <input type="checkbox"/> Replacement Unit <input checked="" type="checkbox"/> To Be Modified <input type="checkbox"/> To be Replaced	N/A	N/A	
							2013	22 ⁵					
DEHY2	TEG Dehydrator: Still Vent and Flash Tank	Unknown	N/A	N/A	20 MMscf/d	20 MMscf/d	N/A	N/A	31000227	<input checked="" type="checkbox"/> Existing (unchanged) <input type="checkbox"/> To be Removed <input type="checkbox"/> New/Additional <input type="checkbox"/> Replacement Unit <input type="checkbox"/> To Be Modified <input type="checkbox"/> To be Replaced	N/A	N/A	
							10/1/2016	DEHY2 ⁴					
23	Flare 2	Hero	N/A	N/A	5 mmscfd	5 mmscfd	N/A	N/A	31000205	<input type="checkbox"/> Existing (unchanged) <input type="checkbox"/> To be Removed <input type="checkbox"/> New/Additional <input type="checkbox"/> Replacement Unit <input checked="" type="checkbox"/> To Be Modified <input type="checkbox"/> To be Replaced	N/A	N/A	
							10/1/2016	23					
24	Glycol Reboiler: DEHY2	N/A	N/A	N/A	1.5 MMBtu/hr	1.5 MMBtu/hr	N/A	N/A	31000228	<input checked="" type="checkbox"/> Existing (unchanged) <input type="checkbox"/> To be Removed <input type="checkbox"/> New/Additional <input type="checkbox"/> Replacement Unit <input type="checkbox"/> To Be Modified <input type="checkbox"/> To be Replaced	N/A	N/A	
							10/1/2016	24					

¹ Unit numbers must correspond to unit numbers in the previous permit unless a complete cross reference table of all units in both permits is provided.

² Specify dates required to determine regulatory applicability.

Table 2-B: Insignificant Activities¹ (20.2.70 NMAC) OR Exempted Equipment (20.2.72 NMAC)

All 20.2.70 NMAC (Title V) applications must list all Insignificant Activities in this table. All 20.2.72 NMAC applications must list Exempted Equipment in this table. If equipment listed on this table is exempt under 20.2.72.202.B.5, include emissions calculations and emissions totals for 20.2.B.5 "similar functions" units, operations, and activities in Section 6, Calculations. Equipment and activities exempted under 20.2.72.202 NMAC may not necessarily be Insignificant under 20.2.70 NMAC (and vice versa). Unit & stack numbering must be consistent throughout the application package. Per Exemptions Policy 02-012.00 (see http://www.env.nm.gov/aqb/permit/aqb_pol.html), 20.2.72.202.B NMAC Exemptions do not apply, but 20.2.72.202.A NMAC exemptions do apply to NOI facilities under 20.2.73 NMAC. List 20.2.72.301.D.4 NMAC Auxiliary Equipment for Streamline applications in Table 2-A. The List of Insignificant Activities (for TV) can be found online at <http://www.env.nm.gov/aqb/forms/InsignificantListTitleV.pdf>. TV sources may elect to enter both TV Insignificant Activities and Part 72 Exemptions on this form.

Unit Number	Source Description	Manufacturer	Model No.	Max Capacity	List Specific 20.2.72.202 NMAC Exemption (e.g. 20.2.72.202.B.5)	Date of Manufacture /Reconstruction ²	For Each Piece of Equipment, Check One	
			Serial No.	Capacity Units	Insignificant Activity citation (e.g. IA List Item #1.a)	Date of Installation /Construction ²		
ACENG	Standby Engine for Air Compressor	Kohler	CH745S	25		2010	<input type="checkbox"/> Existing (unchanged)	<input type="checkbox"/> To be Removed
			Not Specified	HP	IA List Item #7	2010	<input checked="" type="checkbox"/> New/Additional	<input type="checkbox"/> Replacement Unit
6	TEG Reboiler	CE Natco	HLT-1N30805-01	0.5		N/A	<input checked="" type="checkbox"/> Existing (unchanged)	<input type="checkbox"/> To be Removed
			HLT-1N30805-01	MMBtu/hr	IA List Item #1.a	N/A	<input type="checkbox"/> New/Additional	<input type="checkbox"/> Replacement Unit
T36	Freshwater Tank	J&J Steel & Supply Co.	N/A	10000		N/A	<input checked="" type="checkbox"/> Existing (unchanged)	<input type="checkbox"/> To be Removed
			N/A	bb1	IA List Item #1.a	N/A	<input type="checkbox"/> New/Additional	<input type="checkbox"/> Replacement Unit
12	Fire Pump	Caterpillar	3408	166		N/A	<input checked="" type="checkbox"/> Existing (unchanged)	<input type="checkbox"/> To be Removed
			67U10702	hp	IA List Item #1.a	N/A	<input type="checkbox"/> New/Additional	<input type="checkbox"/> Replacement Unit
13	Fire Pump	Caterpillar	3408	166		N/A	<input checked="" type="checkbox"/> Existing (unchanged)	<input type="checkbox"/> To be Removed
			67U10723	hp	IA List Item #1.a	N/A	<input type="checkbox"/> New/Additional	<input type="checkbox"/> Replacement Unit
T-1	TEG Tank	N/A	N/A	1690		1991	<input checked="" type="checkbox"/> Existing (unchanged)	<input type="checkbox"/> To be Removed
			N/A	gal	IA List Item #5	1991	<input type="checkbox"/> New/Additional	<input type="checkbox"/> Replacement Unit
T-2	Methanol Tank	N/A	N/A	1030		1991	<input checked="" type="checkbox"/> Existing (unchanged)	<input type="checkbox"/> To be Removed
			N/A	gal	IA List Item #1.a	1991	<input type="checkbox"/> New/Additional	<input type="checkbox"/> Replacement Unit
T-3	Solvent Tank	N/A	N/A	200		2000	<input checked="" type="checkbox"/> Existing (unchanged)	<input type="checkbox"/> To be Removed
			N/A	gal	IA List Item #5	2000	<input type="checkbox"/> New/Additional	<input type="checkbox"/> Replacement Unit
T-4	Methanol Tank	N/A	N/A	8820		1991	<input checked="" type="checkbox"/> Existing (unchanged)	<input type="checkbox"/> To be Removed
			N/A	gal	IA List Item #1.a	1991	<input type="checkbox"/> New/Additional	<input type="checkbox"/> Replacement Unit
T-5	Lubrication Oil Tank	N/A	N/A	1000		1991	<input checked="" type="checkbox"/> Existing (unchanged)	<input type="checkbox"/> To be Removed
			N/A	gal	IA List Item #5	1991	<input type="checkbox"/> New/Additional	<input type="checkbox"/> Replacement Unit
T-6	Lubrication Oil Tank	N/A	N/A	8820		1985	<input checked="" type="checkbox"/> Existing (unchanged)	<input type="checkbox"/> To be Removed
			N/A	gal	IA List Item #5	1985	<input type="checkbox"/> New/Additional	<input type="checkbox"/> Replacement Unit
T-7	Degreaser Tank	N/A	N/A	325		2000	<input checked="" type="checkbox"/> Existing (unchanged)	<input type="checkbox"/> To be Removed
			N/A	gal	IA List Item #5	2000	<input type="checkbox"/> New/Additional	<input type="checkbox"/> Replacement Unit
T-8	Lubrication Oil Tank	N/A	N/A	1030		1985	<input checked="" type="checkbox"/> Existing (unchanged)	<input type="checkbox"/> To be Removed
			N/A	gal	IA List Item #5	1985	<input type="checkbox"/> New/Additional	<input type="checkbox"/> Replacement Unit
T-9	Antifreeze Tank	N/A	N/A	1000		1991	<input checked="" type="checkbox"/> Existing (unchanged)	<input type="checkbox"/> To be Removed
			N/A	gal	IA List Item #5	1991	<input type="checkbox"/> New/Additional	<input type="checkbox"/> Replacement Unit
T-10	Corrosion Inhibitor Tank	N/A	N/A	800		2000	<input checked="" type="checkbox"/> Existing (unchanged)	<input type="checkbox"/> To be Removed
			N/A	gal	IA List Item #1.a	2000	<input type="checkbox"/> New/Additional	<input type="checkbox"/> Replacement Unit
T-16	Turbine oil Tank	N/A	N/A	470		1979	<input checked="" type="checkbox"/> Existing (unchanged)	<input type="checkbox"/> To be Removed
			N/A	gal	IA List Item #5	1979	<input type="checkbox"/> New/Additional	<input type="checkbox"/> Replacement Unit
T-17	Diesel fuel Tank	N/A	N/A	720		1980	<input checked="" type="checkbox"/> Existing (unchanged)	<input type="checkbox"/> To be Removed
			N/A	gal	IA List Item #5	1980	<input type="checkbox"/> New/Additional	<input type="checkbox"/> Replacement Unit
T-18	Diesel fuel Tank	N/A	N/A	720		1980	<input checked="" type="checkbox"/> Existing (unchanged)	<input type="checkbox"/> To be Removed
			N/A	gal	IA List Item #5	1980	<input type="checkbox"/> New/Additional	<input type="checkbox"/> Replacement Unit
T-19	Emulsion breaker Tank	N/A	0.5"	840		1980	<input checked="" type="checkbox"/> Existing (unchanged)	<input type="checkbox"/> To be Removed
			N/A	gal	IA List Item #1.a	1980	<input type="checkbox"/> New/Additional	<input type="checkbox"/> Replacement Unit
T-20	Corrosion Inhibitor Tank	N/A	N/A	6300		1982	<input checked="" type="checkbox"/> Existing (unchanged)	<input type="checkbox"/> To be Removed
			N/A	gal	IA List Item #1.a	1982	<input type="checkbox"/> New/Additional	<input type="checkbox"/> Replacement Unit
T-21	Scale inhibitor Tank	N/A	N/A	750		1980	<input checked="" type="checkbox"/> Existing (unchanged)	<input type="checkbox"/> To be Removed
			N/A	gal	IA List Item #1.a	1980	<input type="checkbox"/> New/Additional	<input type="checkbox"/> Replacement Unit
T-22	Toluene Tank	N/A	N/A	2000		1980	<input checked="" type="checkbox"/> Existing (unchanged)	<input type="checkbox"/> To be Removed
			N/A	gal	IA List Item #1.a	1980	<input type="checkbox"/> New/Additional	<input type="checkbox"/> Replacement Unit

Table 2-B: Insignificant Activities¹ (20.2.70 NMAC) OR Exempted Equipment (20.2.72 NMAC)

All 20.2.70 NMAC (Title V) applications must list all Insignificant Activities in this table. All 20.2.72 NMAC applications must list Exempted Equipment in this table. If equipment listed on this table is exempt under 20.2.72.202.B.5, include emissions calculations and emissions totals for 20.2.B.5 "similar functions" units, operations, and activities in Section 6, Calculations. Equipment and activities exempted under 20.2.72.202 NMAC may not necessarily be Insignificant under 20.2.70 NMAC (and vice versa). Unit & stack numbering must be consistent throughout the application package. Per Exemptions Policy 02-012.00 (see http://www.env.nm.gov/aqb/permit/aqb_pol.html), 20.2.72.202.B NMAC Exemptions do not apply, but 20.2.72.202.A NMAC exemptions do apply to NOI facilities under 20.2.73 NMAC. List 20.2.72.301.D.4 NMAC Auxiliary Equipment for Streamline applications in Table 2-A. The List of Insignificant Activities (for TV) can be found online at <http://www.env.nm.gov/aqb/forms/InsignificantListTitleV.pdf>. TV sources may elect to enter both TV Insignificant Activities and Part 72 Exemptions on this form.

Unit Number	Source Description	Manufacturer	Model No.	Max Capacity	List Specific 20.2.72.202 NMAC Exemption (e.g. 20.2.72.202.B.5)	Date of Manufacture /Reconstruction ²	For Each Piece of Equipment, Check One
			Serial No.	Capacity Units	Insignificant Activity citation (e.g. IA List Item #1.a)	Date of Installation /Construction ²	
T-23	Scale inhibitor Tank	N/A	N/A	750		1980	X Existing (unchanged) <input type="checkbox"/> To be Removed
			N/A	gal	IA List Item #5	1980	<input type="checkbox"/> New/Additional <input type="checkbox"/> Replacement Unit
T-24	Packing Fluid Tank	N/A	N/A	750		2000	X Existing (unchanged) <input type="checkbox"/> To be Removed
			N/A	gal	IA List Item #1.a	2000	<input type="checkbox"/> New/Additional <input type="checkbox"/> Replacement Unit
T-25	Paraffin dispersant Tank	N/A	N/A	190		1980	X Existing (unchanged) <input type="checkbox"/> To be Removed
			N/A	gal	IA List Item #5	1980	<input type="checkbox"/> New/Additional <input type="checkbox"/> Replacement Unit
T-26	Corrosion Inhibitor Tank	N/A	N/A	80		1980	X Existing (unchanged) <input type="checkbox"/> To be Removed
			N/A	gal	IA List Item #5	1980	<input type="checkbox"/> New/Additional <input type="checkbox"/> Replacement Unit
T-27	Surfactant Tank	N/A	N/A	400		1980	X Existing (unchanged) <input type="checkbox"/> To be Removed
			N/A	gal	IA List Item #5	1980	<input type="checkbox"/> New/Additional <input type="checkbox"/> Replacement Unit
T-28	Oxygen scavenger Tank	N/A	N/A	80		1980	X Existing (unchanged) <input type="checkbox"/> To be Removed
			N/A	gal	IA List Item #5	1980	<input type="checkbox"/> New/Additional <input type="checkbox"/> Replacement Unit
T-29	Emulsion breaker Tank	N/A	N/A	180		1980	X Existing (unchanged) <input type="checkbox"/> To be Removed
			N/A	gal	IA List Item #5	1980	<input type="checkbox"/> New/Additional <input type="checkbox"/> Replacement Unit
T-30	Methanol Tank	N/A	N/A	130		2000	X Existing (unchanged) <input type="checkbox"/> To be Removed
			N/A	gal	IA List Item #1.a	2000	<input type="checkbox"/> New/Additional <input type="checkbox"/> Replacement Unit
T-31	Scale Remover Tank	N/A	N/A	750		1980	X Existing (unchanged) <input type="checkbox"/> To be Removed
			N/A	gal	IA List Item #1.a	1980	<input type="checkbox"/> New/Additional <input type="checkbox"/> Replacement Unit
T-32	Wetting Agent Tank	N/A	N/A	225		2000	X Existing (unchanged) <input type="checkbox"/> To be Removed
			N/A	gal	IA List Item #5	2000	<input type="checkbox"/> New/Additional <input type="checkbox"/> Replacement Unit
T-33	Scale inhibitor Tank	N/A	N/A	535		2001	X Existing (unchanged) <input type="checkbox"/> To be Removed
			N/A	gal	IA List Item #1.a	2001	<input type="checkbox"/> New/Additional <input type="checkbox"/> Replacement Unit
T-34	Surfactant Tank	N/A	N/A	130		2001	X Existing (unchanged) <input type="checkbox"/> To be Removed
			N/A	gal	IA List Item #5	2001	<input type="checkbox"/> New/Additional <input type="checkbox"/> Replacement Unit
T-35	Turbine oil Tank	N/A	N/A	200		2000	X Existing (unchanged) <input type="checkbox"/> To be Removed
			N/A	gal	IA List Item #5	2000	<input type="checkbox"/> New/Additional <input type="checkbox"/> Replacement Unit
T-37	Sour NGL (pressurized)	N/A	N/A	12000		1980	X Existing (unchanged) <input type="checkbox"/> To be Removed
			N/A	gal	IA List Item #1.a	1980	<input type="checkbox"/> New/Additional <input type="checkbox"/> Replacement Unit
T-38	Sour NGL (pressurized)	N/A	N/A	12000		1980	X Existing (unchanged) <input type="checkbox"/> To be Removed
			N/A	gal	IA List Item #1.a	1980	<input type="checkbox"/> New/Additional <input type="checkbox"/> Replacement Unit
T-39	Refrigerant Tank	N/A	N/A	11000		1980	X Existing (unchanged) <input type="checkbox"/> To be Removed
			N/A	gal	IA List Item #5	1980	<input type="checkbox"/> New/Additional <input type="checkbox"/> Replacement Unit
T-43	Emulsion breaker Tank	N/A	N/A	80		1980	X Existing (unchanged) <input type="checkbox"/> To be Removed
			N/A	gal	IA List Item #5	1980	<input type="checkbox"/> New/Additional <input type="checkbox"/> Replacement Unit
T-44	Paraffin Tank	N/A	N/A	80		1980	X Existing (unchanged) <input type="checkbox"/> To be Removed
			N/A	gal	IA List Item #5	1980	<input type="checkbox"/> New/Additional <input type="checkbox"/> Replacement Unit
T-45	Paraffin Tank	N/A	N/A	80		1980	X Existing (unchanged) <input type="checkbox"/> To be Removed
			N/A	gal	IA List Item #5	1980	<input type="checkbox"/> New/Additional <input type="checkbox"/> Replacement Unit
T-46	Paraffin Tank	N/A	N/A	600		2000	X Existing (unchanged) <input type="checkbox"/> To be Removed
			N/A	gal	IA List Item #5	2000	<input type="checkbox"/> New/Additional <input type="checkbox"/> Replacement Unit
T-47	Surfactant Tank	N/A	N/A	190		1980	X Existing (unchanged) <input type="checkbox"/> To be Removed
			N/A	gal	IA List Item #5	1980	<input type="checkbox"/> New/Additional <input type="checkbox"/> Replacement Unit

¹ Insignificant activities exempted due to size or production rate are defined in 20.2.70.300.D.6, 20.2.70.7.Q NMAC, and the NMED/AQB List of Insignificant Activities, dated September 15, 2008. Emissions from these insignificant activities do not need to be reported, unless specifically requested.

² Specify date(s) required to determine regulatory applicability.

Table 2-D: Maximum Emissions (under normal operating conditions)

☐ This Table was intentionally left blank because it would be identical to Table 2-E.

Maximum Emissions are the emissions at maximum capacity and prior to (in the absence of) pollution control, emission-reducing process equipment, or any other emission reduction. Calculate the hourly emissions using the worst case hourly emissions for each pollutant. For each pollutant, calculate the annual emissions as if the facility were operating at maximum plant capacity without pollution controls for 8760 hours per year, unless otherwise approved by the Department. List Hazardous Air Pollutants (HAP) & Toxic Air Pollutants (TAPs) in Table 2-I. Unit & stack numbering must be consistent throughout the application package. Fill all cells in this table with the emission numbers or a "-" symbol. A "--" symbol indicates that emissions of this pollutant are not expected. Numbers shall be expressed to at least 2 decimal points (e.g. 0.41, 1.41, or 1.41E-4).

Unit No.	NOx		CO		VOC		SOx		PM ¹		PM10 ¹		PM2.5 ¹		H ₂ S		Lead	
	lb/hr	ton/yr	lb/hr	ton/yr	lb/hr	ton/yr	lb/hr	ton/yr	lb/hr	ton/yr	lb/hr	ton/yr	lb/hr	ton/yr	lb/hr	ton/yr	lb/hr	ton/yr
1	3.3	14.4	4.6	20.2	0.6	2.5	0.2	0.9	0.1	0.4	0.1	0.4	0.1	0.4	-	-	-	-
2	3.3	14.4	4.6	20.2	0.6	2.5	0.2	0.9	0.1	0.4	0.1	0.4	0.1	0.4	-	-	-	-
3	3.3	14.4	4.6	20.2	0.6	2.5	0.2	0.9	0.1	0.4	0.1	0.4	0.1	0.4	-	-	-	-
4	3.3	14.4	4.6	20.2	0.6	2.5	0.2	0.9	0.1	0.4	0.1	0.4	0.1	0.4	-	-	-	-
7	1.7	7.3	1.4	6.1	0.09	0.40	0.2	1.0	0.1	0.6	0.1	0.6	0.1	0.6	-	-	-	-
16	23.4	102.5	36.4	159.4	0.39	1.71	0.1	0.3	0.0	0.2	0.0	0.2	0.0	0.2	-	-	-	-
17	23.4	102.5	36.4	159.4	0.39	1.71	0.1	0.3	0.0	0.2	0.0	0.2	0.0	0.2	-	-	-	-
19	-	-	-	-	2705.8	6172.6	-	-	-	-	-	-	-	-	526.9	2308.0	-	-
20 or 21	-	-	-	-	-	-	-	-	-	-	-	-	-	-	-	-	-	-
FUG1	-	-	-	-	12.2	53.6	-	-	-	-	-	-	-	-	0.0	0.1	-	-
FUG2	-	-	-	-	0.1	0.4	-	-	-	-	-	-	-	-	-	-	-	-
22	-	-	-	-	808.3	3540.5	-	-	-	-	-	-	-	-	27.6	120.7	-	-
24	0.2	0.7	0.1	0.6	0.0	0.0	0.0	0.1	0.0	0.1	0.0	0.1	0.0	0.1	-	-	-	-
23	Emissions for Units 19 and 23 are combined, with a maximum daily flare volume of 5 mmscf and 1.5% H2S. Annual limits are also combined. Both units can operate at the same time.																	
T-11	-	-	-	-	90.8	397.5	-	-	-	-	-	-	-	-	13.4	58.9	-	-
T-12	-	-	-	-	54.2	237.4	-	-	-	-	-	-	-	-	0.2	0.7	-	-
T-13	-	-	-	-	369.6	1618.7	-	-	-	-	-	-	-	-	1.1	4.9	-	-
T-14	-	-	-	-	401.8	1760.0	-	-	-	-	-	-	-	-	1.2	5.3	-	-
T-15	-	-	-	-	10.3	45.0	-	-	-	-	-	-	-	-	7.6	33.3	-	-
NGL/CO2	-	-	-	-	-	-	-	-	-	-	-	-	-	-	-	-	-	-
T-42	Emergency Use Only																	
DEHY1	Closed loop system with vent routed to inlet.																	
DEHY2	Closed loop system with vent routed to inlet.																	
Totals²	61.8	270.7	92.7	406.2	3647.8	13839.4	1.2	5.2	0.6	2.5	0.6	2.5	0.6	2.5	550.5	2532.0		

¹ **Condensable Particulate Matter:** Include condensable particulate matter emissions for PM10 and PM2.5 if the source is a combustion source. Do not include condensable particulate matter for PM unless PM is set equal to PM10 and PM2.5. Particulate matter (PM) is not subject to an ambient air quality standard, but PM is a regulated air pollutant under PSD (20.2.74 NMAC) and Title V (20.2.70 NMAC).

² Hourly rates do not include Unit 22 as this unit is not operated while the plant is fully operating. Unit 22 operates only when the plant is shutdown for a turnaround.

Table 2-E: Requested Allowable Emissions

Unit & stack numbering must be consistent throughout the application package. Fill all cells in this table with the emission numbers or a "-" symbol. A "--" symbol indicates that emissions of this pollutant are not expected. Numbers shall be expressed to at least 2 decimal points (e.g. 0.41, 1.41, or 1.41E⁻⁴).

Unit No.	NOx		CO		VOC		SOx		PM ¹		PM10 ¹		PM2.5 ¹		H ₂ S		Lead	
	lb/hr	ton/yr	lb/hr	ton/yr	lb/hr	ton/yr	lb/hr	ton/yr	lb/hr	ton/yr	lb/hr	ton/yr	lb/hr	ton/yr	lb/hr	ton/yr	lb/hr	ton/yr
1	3.3	14.4	4.6	20.2	0.6	2.5	0.2	0.9	0.1	0.4	0.1	0.4	0.1	0.4	-	-		
2	3.3	14.4	4.6	20.2	0.6	2.5	0.2	0.9	0.1	0.4	0.1	0.4	0.1	0.4	-	-		
3	3.3	14.4	4.6	20.2	0.6	2.5	0.2	0.9	0.1	0.4	0.1	0.4	0.1	0.4	-	-		
4	3.3	14.4	4.6	20.2	0.6	2.5	0.2	0.9	0.1	0.4	0.1	0.4	0.1	0.4	-	-		
7	1.7	7.3	1.4	6.1	0.1	0.4	0.2	1.0	0.1	0.6	0.1	0.6	0.1	0.6	-	-		
16	2.5	11.1	3.9	17.1	0.2	0.7	0.1	0.3	0.0	0.2	0.0	0.2	0.0	0.2	-	-		
17	2.5	11.1	3.9	17.1	0.2	0.7	0.1	0.3	0.0	0.2	0.0	0.2	0.0	0.2	-	-		
19	0.0	0.1	0.1	0.5	0.0	0.0	0.0	0.0	-	-	-	-	-	-	0.0	0.0	-	-
20 or 21	-	-	-	-	-	-	-	-	-	-	-	-	-	-	-	-	-	-
FUG1	-	-	-	-	12.2	53.6	-	-	-	-	-	-	-	-	0.0	0.1	-	-
FUG2	-	-	-	-	0.1	0.4	-	-	-	-	-	-	-	-	-	-	-	-
NGL/CO ₂	-	-	-	-	-	-	-	-	-	-	-	-	-	-	-	-	-	-
22	0.0	0.0	0.0	0.0	0.0	0.0	0.0	0.0	-	-	-	-	-	-	0.0	0.0	-	-
24	0.2	0.7	0.1	0.6	0.0	0.0	0.0	0.1	0.0	0.1	0.01	0.06	0.01	0.06	-	-	-	-
23	Emissions for Units 19 and 23 are combined, with a maximum daily flare volume of 5 mmsecf and 1.5% H2S. Annual limits are also combined. Both units can operate at the same time.																	
T-15	Emissions are controlled using a redundant VRU system. During plant turnarounds, any emissions would be routed to Flare Unit 22.																	
T-12	Emissions are controlled using a redundant VRU system. During plant turnarounds, any emissions would be routed to Flare Unit 22.																	
T-11	Emissions are controlled using a redundant VRU system. During plant turnarounds, any emissions would be routed to Flare Unit 22.																	
T-14	Emissions are controlled using a redundant VRU system. During plant turnarounds, any emissions would be routed to Flare Unit 22.																	
T-13	Emissions are controlled using a redundant VRU system. During plant turnarounds, any emissions would be routed to Flare Unit 22.																	
NGL/CO ₂	-	-	-	-	-	-	-	-	-	-	-	-	-	-	-	-	-	-
T-42	Emergency Use Only																	
DEHY1	Closed loop system with vent routed to inlet.																	
DEHY2	Closed loop system with vent routed to inlet.																	
Totals²	20.1	88.0	27.9	122.1	15.0	65.7	1.2	5.2	0.6	2.5	0.6	2.5	0.6	2.5	0.0	0.1		

¹Condensable Particulate Matter: Include condensable particulate matter emissions for PM10 and PM2.5 if the source is a combustion source. Do not include condensable particulate matter for PM unless PM is set equal to PM10 and PM2.5. Particulate matter (PM) is not subject to an ambient air quality standard, but PM is a regulated air pollutant under PSD (20.2.74 NMAC) and Title V (20.2.70 NMAC).

²Annual totals include Temporary Flare Unit 22 during which the Process Flares (Units 19/23) are shutdown and the facility inlet shut-in for planned maintenance. Hourly totals do not since the two cannot occur at the same time.

Table 2-F: Additional Emissions during Startup, Shutdown, and Routine Maintenance (SSM)

□ This table is intentionally left blank since all emissions at this facility due to routine or predictable startup, shutdown, or scheduled maintenance are no higher than those listed in Table 2-E and a malfunction emission limit is not already permitted or requested. If you are required to report GHG emissions as described in Section 6a, include any GHG emissions during Startup, Shutdown, and/or Scheduled Maintenance (SSM) in Table 2-P. Provide an explanation of SSM emissions in Section 6 and 6a.

All applications for facilities that have emissions during routine or predictable startup, shutdown or scheduled maintenance (SSM)¹, including NOI applications, must include in this table the Maximum Emissions during routine or predictable startup, shutdown and scheduled maintenance (20.2.7 NMAC, 20.2.72.203.A.3 NMAC, 20.2.73.200.D.2 NMAC). In Section 6 and 6a, provide emissions calculations for all SSM emissions reported in this table. Refer to "Guidance for Submittal of Startup, Shutdown, Maintenance Emissions in Permit Applications (https://www.env.nm.gov/aqb/permit/aqb_pol.html) for more detailed instructions. Numbers shall be expressed to at least 2 decimal points (e.g. 0.41, 1.41, or 1.41E-4).

Unit No.	NOx		CO		VOC		SOx		PM ¹		PM10 ¹		PM2.5 ¹		H ₂ S		Lead	
	lb/hr	ton/yr	lb/hr	ton/yr	lb/hr	ton/yr	lb/hr	ton/yr	lb/hr	ton/yr	lb/hr	ton/yr	lb/hr	ton/yr	lb/hr	ton/yr	lb/hr	ton/yr
19/23	8.3	2.2	71.1	19.1	54.1	11.6	990.6	212.8	-	-	-	-	-	-	10.5	2.3		
22	0.5	0.3	2.9	1.6	5.5	3.0	51.80	28.00	-	-	-	-	-	-	0.6	0.3		
Totals	8.3	2.5	71.1	20.7	54.1	14.6	990.6	240.8	-	-	-	-	-	-	10.54	2.56		

¹ For instance, if the short term steady-state Table 2-E emissions are 5 lb/hr and the SSM rate is 12 lb/hr, enter 7 lb/hr in this table. If the annual steady-state Table 2-E emissions are 21.9 TPY, and the number of scheduled SSM events result in annual emissions of 31.9 TPY, enter 10.0 TPY in the table below.

² **Condensable Particulate Matter:** Include condensable particulate matter emissions for PM10 and PM2.5 if the source is a combustion source. Do not include condensable particulate matter for PM unless PM is set equal to PM10 and PM2.5. Particulate matter (PM) is not subject to an ambient air quality standard, but it is a regulated air pollutant under PSD (20.2.74 NMAC) and Title V (20.2.70 NMAC).

Table 2-J: Fuel

Specify fuel characteristics and usage. Unit and stack numbering must correspond throughout the application package.

Unit No.	Fuel Type (low sulfur Diesel, ultra low sulfur diesel, Natural Gas, Coal, ...)	Fuel Source: purchased commercial, pipeline quality natural gas, residue gas, raw/field natural gas, process gas (e.g. SRU tail gas) or other	Specify Units				
			Lower Heating Value (Btu/scf)	Hourly Usage (Mscf)	Annual Usage (MMscf)	% Sulfur	% Ash
1	Natural Gas	Purchased Commercial	905	14.1	123.5	5 gr/100 scf	Negligible
2	Natural Gas	Purchased Commercial	905	14.1	123.5	5 gr/100 scf	Negligible
3	Natural Gas	Purchased Commercial	905	14.1	123.5	5 gr/100 scf	Negligible
4	Natural Gas	Purchased Commercial	905	14.1	123.5	5 gr/100 scf	Negligible
7	Natural Gas	Purchased Commercial	905	16.6	145.2	5 gr/100 scf	Negligible
16	Natural Gas	Purchased Commercial	905	5.0	43.4	5 gr/100 scf	Negligible
17	Natural Gas	Purchased Commercial	905	5.0	43.4	5 gr/100 scf	Negligible
19	Natural Gas	Purchased Commercial	905	0.1	0.0	5 gr/100 scf	Negligible
22	Natural Gas	Purchased Commercial	905	0.1	0.0	5 gr/100 scf	Negligible
6	Natural Gas	Purchased Commercial	905	0.6	4.8	5 gr/100 scf	Negligible
24	Natural Gas	Purchased Commercial	905	1.7	14.5	5 gr/100 scf	Negligible
23	Natural Gas	Purchased Commercial	905	0.1	0.0	5 gr/100 scf	Negligible

Table 2-K: Liquid Data for Tanks Listed in Table 2-L

For each tank, list the liquid(s) to be stored in each tank. If it is expected that a tank may store a variety of hydrocarbon liquids, enter "mixed hydrocarbons" in the Composition column for that tank and enter the corresponding data of the most volatile liquid to be stored in the tank. If tank is to be used for storage of different materials, list all the materials in the "All Calculations" attachment, run the newest version of TANKS on each, and use the material with the highest emission rate to determine maximum uncontrolled and requested allowable emissions rate. The permit will specify the most volatile category of liquids that may be stored in each tank. Include appropriate tank-flashing modeling input data. Use additional sheets if necessary. Unit and stack numbering must correspond throughout the application package.

Tank No.	SCC Code	Material Name	Composition	Liquid Density (lb/gal)	Vapor Molecular Weight (lb/lb*mol)	Average Storage Conditions		Max Storage Conditions	
						Temperature (°F)	True Vapor Pressure (psia)	Temperature (°F)	True Vapor Pressure (psia)
T-11	40400311	Oil/Water Mixture	Oil/Water Mixture	8.3	42.5	49.3	10.5	77.2	13.3
T-12	40400311	Produced water	Water, trace hydrocarbons	6.9	51.2	49.3	9.1	77.2	12.1
T-13	40400311	Produced water	Water, trace hydrocarbons	8.3	49.5	49.3	9.1	77.2	12.1
T-14	40400311	Produced water	Water, trace hydrocarbons	6.6	49.5	49.3	9.1	77.2	12.1
T-15	40400315	Produced water	Water, trace hydrocarbons	8.3	42.0	49.3	10.6	77.2	13.3
T-36	N/A	Fresh Water	Fresh Water	N/A	N/A	N/A	N/A	N/A	N/A
T-42	N/A	Produce Water/Oil	Water, trace hydrocarbons	Emergency Use Only					

Table 2-L: Tank Data

Include appropriate tank-flashing modeling input data. Use an addendum to this table for unlisted data categories. Unit and stack numbering must correspond throughout the application package. Use additional sheets if necessary. See reference Table 2-L2. Note: 1.00 bbl = 10.159 M3 = 42.0 gal

Tank No.	Date Installed	Materials Stored	Seal Type (refer to Table 2-LR below)	Roof Type (refer to Table 2-LR below)	Capacity		Diameter (M)	Vapor Space (M)	Color (from Table VI-C)		Paint Condition (from Table VI-C)	Annual Throughput (gal/yr)	Turn-overs (per year)
					(bbl)	(M ³)			Roof	Shell			
T-11	1979	Crude Oil	N/A	FX	10,000	1,590	16.8	7.3	WH	WH	Good	936,862,290	2230.6
T-12	1979	Produced Water	N/A	FX	10,000	1,590	16.8	7.3	WH	WH	Good	2,381,516	5.7
T-13	1979	Crude Oil	N/A	FX	5,000	795	11.8	7.3	WH	WH	Good	21,790,062	103.8
T-14	1979	Crude Oil	N/A	FX	10,000	1,590	16.8	7.3	WH	WH	Good	23,546,880	56.1
T-15	2004	Produced water	N/A	FX	10,000	1,590	16.8	7.3	WH	WH	Good	935,130,000	2226.5
T-42	2004	Oil or Produced Water	N/A	FX	15,000	2,385	18.3	9.75	WH	WH	Good	Emergency Use Only	

Table 2-P: Green House Gas Emissions

Applications submitted under 20.2.70, 20.2.72, & 20.2.74 NMAC are required to complete this Table. Power plants, Title V major sources, and PSD major sources must report and calculate all GHG emissions for each unit. Applicants must report potential emission rates in short tons per year (see Section 6.a for assistance). Include GHG emissions during Startup, Shutdown, and Scheduled Maintenance in this table. For minor source facilities that are not power plants, are not Title V, or are not PSD, there are three options for reporting GHGs 1) report GHGs for each individual piece of equipment; 2) report all GHGs from a group of unit types, for example report all combustion source GHGs as a single unit and all venting GHG as a second separate unit; OR 3) check the following box By checking this box, the applicant acknowledges the total CO2e emissions are less than 75,000 tons per year.

		CO ₂ ton/yr	N ₂ O ton/yr	CH ₄ ton/yr	SF ₆ ton/yr	PFC/HFC ton/yr ²										Total GHG Mass Basis ton/yr ⁴	Total CO ₂ e ton/yr ⁵
Unit No.	GWPs¹	1	298	25	22,800	footnote 3											
1	mass GHG	6537.65	0.01	0.03												6538	
	CO ₂ e	6537.65	3.67	0.70													6542
2	mass GHG	6537.65	0.01	0.03												6538	
	CO ₂ e	6537.65	3.67	0.70													6542
3	mass GHG	6537.65	0.01	0.03												6538	
	CO ₂ e	6537.65	3.67	0.70													6542
4	mass GHG	6537.65	0.01	0.03												6538	
	CO ₂ e	6537.65	3.67	0.70													6542
7	mass GHG	7686.72	0.01	0.14												7687	
	CO ₂ e	7686.72	4.32	3.62													7695
16	mass GHG	2295.66	0.00	0.04												2296	
	CO ₂ e	2295.66	1.29	1.08													2298
17	mass GHG	2295.66	0.00	0.04												2296	
	CO ₂ e	2295.66	1.29	1.08													2298
19/23	mass GHG	10004.49	0.00	7.35												10012	
	CO ₂ e	10004.49	0.00	183.68													10188
22	mass GHG	2004.52	0.00	0.32												2005	
	CO ₂ e	2004.52	0.00	7.90													2012
19/23 (Pilot)	mass GHG	56.09	0.00	0.04												56	
	CO ₂ e	56.09	0.00	1.03													57
24	mass GHG	768.67	0.00	0.01												769	
	CO ₂ e	768.67	0.43	0.36													769
22 (Pilot)	mass GHG	85.85	0.00	0.01												86	
	CO ₂ e	85.85	0.00	0.34													86
	mass GHG																
	CO ₂ e																
Total	mass GHG															51356	
	CO ₂ e																51572

¹ GWP (Global Warming Potential): Applicants must use the most current GWPs codified in Table A-1 of 40 CFR part 98. GWPs are subject to change, therefore, applicants need to check 40 CFR 98 to confirm GWP value

² For HFCs or PFCs describe the specific HFC or PFC compound and use a separate column for each individual compound.

³ For each new compound, enter the appropriate GWP for each HFC or PFC compound from Table A-1 in 40 CFR 98.

⁴ Green house gas emissions on a mass basis is the ton per year green house gas emission before adjustment with its GWP.

⁵ CO₂e means Carbon Dioxide Equivalent and is calculated by multiplying the TPY mass emissions of the green house gas by its GWP.

Tab 3
Section 3 - Application Summary

Section 3

Application Summary

The **Application Summary** shall include a brief description of the facility and its process, the type of permit application, the applicable regulation (i.e. 20.2.72.200.A.X, or 20.2.73 NMAC) under which the application is being submitted, and any air quality permit numbers associated with this site. If this facility is to be collocated with another facility, provide details of the other facility including permit number(s). In case of a revision or modification to a facility, provide the lowest level regulatory citation (i.e. 20.2.72.219.B.1.d NMAC) under which the revision or modification is being requested. Also describe the proposed changes from the original permit, how the proposed modification will affect the facility's operations and emissions, de-bottlenecking impacts, and changes to the facility's major/minor status (both PSD & Title V).

The **Process Summary** shall include a brief description of the facility and its processes.

Startup, Shutdown, and Maintenance (SSM) routine or predictable emissions: Provide an overview of how SSM emissions are accounted for in this application. Refer to "Guidance for Submittal of Startup, Shutdown, Maintenance Emissions in Permit Applications (http://www.env.nm.gov/aqb/permit/app_form.html) for more detailed instructions on SSM emissions.

This application is submitted as a Significant Modification to Title V Operating Permit P092 in accordance with 20.2.70.404.C.1.b. ConocoPhillips (COP) is requesting the changed made with NSR Permits 218-M9 and 218-M9R1 be incorporated into the Title V Operating Permit. COP is also requesting this application be used for renewal of the Title V Operating Permit.

On May 29, 2020, COP submitted applications to revise NSR Permit 218-M9 and modify/renew Title V Permit P092. The NSR application requested replacement of several storage tanks at the EVLRP Battery. COP subsequently decided to make repairs on the existing tanks instead of replacing the tanks. During the Air Quality Bureau's review of the application, COP was asked to update flare calculations for Units 19/23 and 22. This was not done in past applications as COP has not requested modifications to the flare limitations. Emissions from Units 19/23 were updated using recent analytical data and safety factors that were more aligned with current Bureau policy. Flare 22 emissions were not updated in the recent NSR revisions since the change from AP-42 factors to TCEQ factors could not be made without a significant revision to the permit; therefore, the existing limitations for Unit 22 were retained and updated calculations are not provided in this application. Note there has been no change in the method of operation, only an update to the gas analyses used.

In addition, COP added a standby engine used to power an air compressor at the tank battery. The unit would only be used in the event of a power outage or for maintenance. This unit is on the List of Insignificant Activities dated March 24, 2005.

Other combustion-related routine SSM emissions are included with emissions from normal operation of the facility.

Tab 4
Section 4 - Process Flow Sheet

Section 4

Process Flow Sheet

A **process flow sheet** and/or block diagram indicating the individual equipment, all emission points and types of control applied to those points. The unit numbering system should be consistent throughout this application.

A process flow diagram is included.

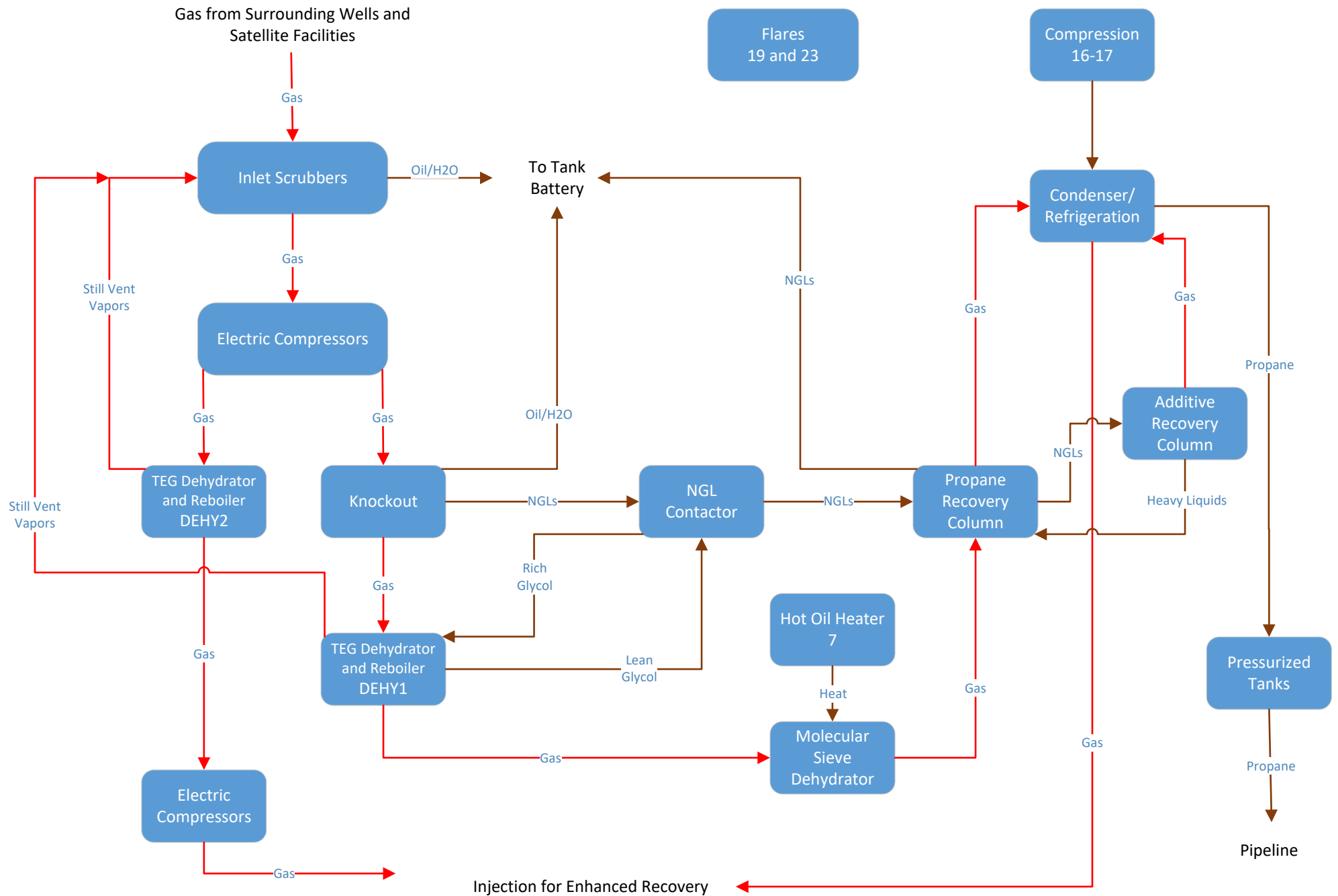

Tab 5
Section 5 - Plot Plan Drawn To Scale

Section 5

Plot Plan Drawn To Scale

A **plot plan drawn to scale** showing emissions points, roads, structures, tanks, and fences of property owned, leased, or under direct control of the applicant. This plot plan must clearly designate the restricted area as defined in UA1, Section 1-D.12. The unit numbering system should be consistent throughout this application.

A plot plan is included.

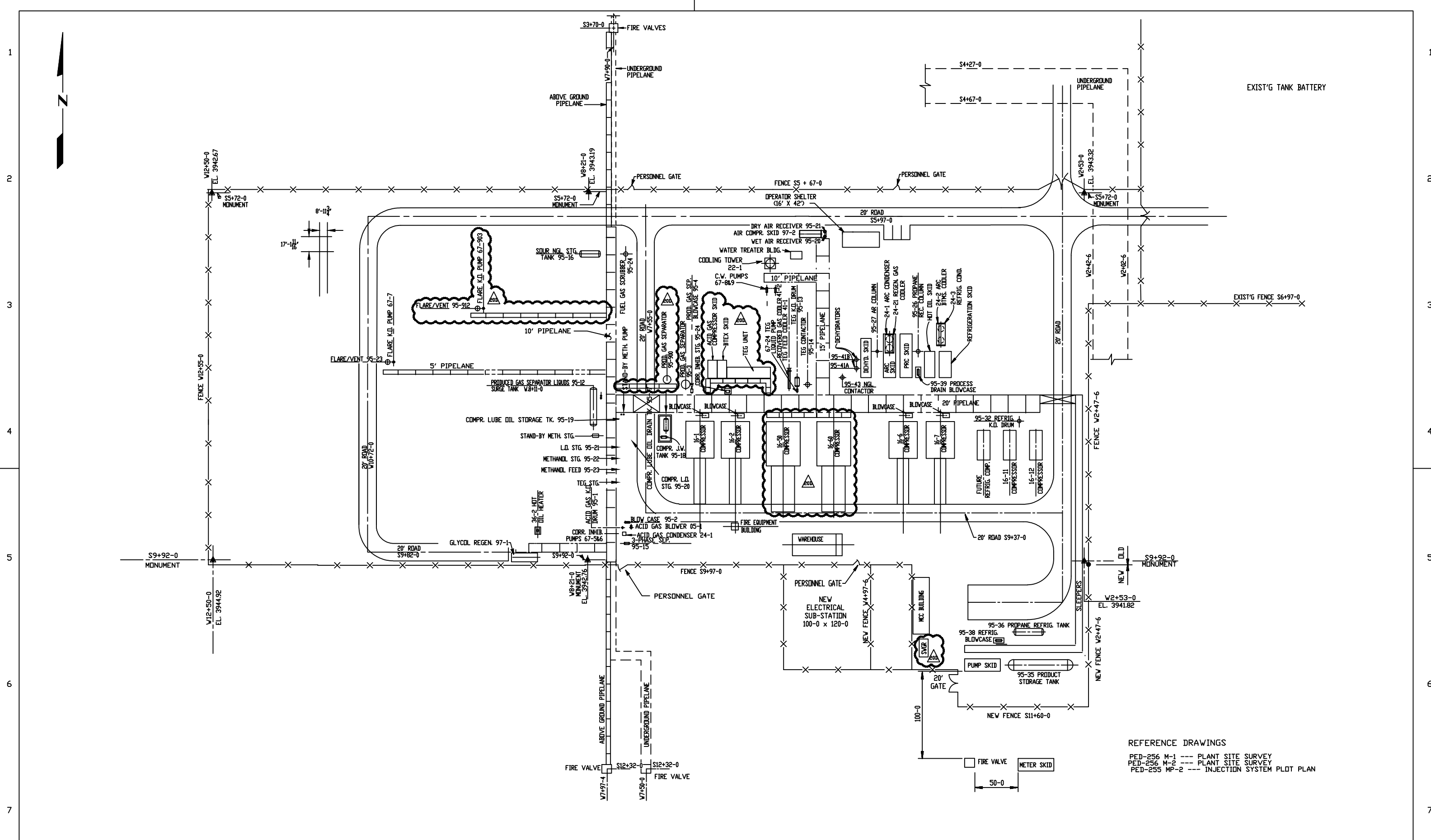

REFERENCE DRAWINGS
 PED-256 M-1 --- PLANT SITE SURVEY
 PED-256 M-2 --- PLANT SITE SURVEY
 PED-255 MP-2 --- INJECTION SYSTEM PLOT PLAN

NO.	REVISION	BY	DATE	10	11	12	13	14	15	16	17	18	19	20	21
	REVISED PER AS BUILT.	P-KNS1	DMG	6/86	ELR	6/86	DMG	14	CFD	2-9-91	18	ADDED COMP. #16-6 AND BLOWCASE	wrt	3/12/92	
	RELOCATED 16-3 & 95-7 AND SHOWED AS NEW.	P-C131	JF	11/87	ELR	11/87	JF	15	CFD	9-19-91	19	ADDED COMP. #16-7 AND BLOWCASE	JAM	4/8/93	
8	REMOVED ACCESS WALKWAY, MOVED COOLING TWR & WTR. TREATER BLDG.	P-KNS1	RDB	12/19/85	JHM	11/88	JHM	16	CFD	2-24-92	20	AS-BUILT	wrt	7/27/93	
9	REV. & ADDED NEW PERSONNEL GATE	P-KNS1	DMG	2/86	JAM	5/91	JAM	17	CFD	9-22-92	20	ISSUED FOR RFQ	JW	12/31/13	

ABBR JOB 80110 9-22-92

FDR BIDS		PHILLIPS PETROLEUM COMPANY BARTLESVILLE, OKLAHOMA PLOT PLAN EAST VACUUM CO2 REINJECTION PLANT	JA NO.	569241	FILE CODE	S07
FDR APPR			AFE NO.	P-KNS1	SCALE	1"=50'-0"
FDR CONST	1-9-4-84 RAE.		DWG NO.	PED-256	SH NO.	MP-2-20
DRAWNR.	BARRINGER		3/84			
CHECKED	JAT	8/84				
APP'D	RE	8/84				

EAST VACUUM PLANT LEA COUNTY, NEW MEXICO
 HCAD # MP2N COORDINATE REV. W/ CAD SUPV

Tab 6
Section 6 - All Calculations

Section 6

All Calculations

Show all calculations used to determine both the hourly and annual controlled and uncontrolled emission rates. All calculations shall be performed keeping a minimum of three significant figures. Document the source of each emission factor used (if an emission rate is carried forward and not revised, then a statement to that effect is required). If identical units are being permitted and will be subject to the same operating conditions, submit calculations for only one unit and a note specifying what other units to which the calculations apply. All formulas and calculations used to calculate emissions must be submitted. The "Calculations" tab in the UA2 has been provided to allow calculations to be linked to the emissions tables. Add additional "Calc" tabs as needed. If the UA2 or other spread sheets are used, all calculation spread sheet(s) shall be submitted electronically in Microsoft Excel compatible format so that formulas and input values can be checked. Format all spread sheets and calculations such that the reviewer can follow the logic and verify the input values. Define all variables. If calculation spread sheets are not used, provide the original formulas with defined variables. Additionally, provide subsequent formulas showing the input values for each variable in the formula. All calculations, including those calculations are imbedded in the Calc tab of the UA2 portion of the application, the printed Calc tab(s), should be submitted under this section.

Tank Flashing Calculations: The information provided to the AQB shall include a discussion of the method used to estimate tank-flashing emissions, relative thresholds (i.e., NOI, permit, or major source (NSPS, PSD or Title V)), accuracy of the model, the input and output from simulation models and software, all calculations, documentation of any assumptions used, descriptions of sampling methods and conditions, copies of any lab sample analysis. If Hysis is used, all relevant input parameters shall be reported, including separator pressure, gas throughput, and all other relevant parameters necessary for flashing calculation.

SSM Calculations: It is the applicant's responsibility to provide an estimate of SSM emissions or to provide justification for not doing so. In this Section, provide emissions calculations for Startup, Shutdown, and Routine Maintenance (SSM) emissions listed in the Section 2 SSM and/or Section 22 GHG Tables and the rationale for why the others are reported as zero (or left blank in the SSM/GHG Tables). Refer to "Guidance for Submittal of Startup, Shutdown, Maintenance Emissions in Permit Applications (http://www.env.nm.gov/aqb/permit/app_form.html) for more detailed instructions on calculating SSM emissions. If SSM emissions are greater than those reported in the Section 2, Requested Allowables Table, modeling may be required to ensure compliance with the standards whether the application is NSR or Title V. Refer to the Modeling Section of this application for more guidance on modeling requirements.

Glycol Dehydrator Calculations: The information provided to the AQB shall include the manufacturer's maximum design recirculation rate for the glycol pump. If GRI-Glycalc is used, the full input summary report shall be included as well as a copy of the gas analysis that was used.

Road Calculations: Calculate fugitive particulate emissions and enter haul road fugitives in Tables 2-A, 2-D and 2-E for:

1. If you transport raw material, process material and/or product into or out of or within the facility and have PER emissions greater than 0.5 tpy.
2. If you transport raw material, process material and/or product into or out of the facility more frequently than one round trip per day.

Significant Figures:

A. All emissions standards are deemed to have at least two significant figures, but not more than three significant figures.

B. At least 5 significant figures shall be retained in all intermediate calculations.

C. In calculating emissions to determine compliance with an emission standard, the following rounding off procedures shall be used:

- (1) If the first digit to be discarded is less than the number 5, the last digit retained shall not be changed;
- (2) If the first digit discarded is greater than the number 5, or if it is the number 5 followed by at least one digit other than the number zero, the last figure retained shall be increased by one unit; **and**
- (3) If the first digit discarded is exactly the number 5, followed only by zeros, the last digit retained shall be rounded upward if it is an odd number, but no adjustment shall be made if it is an even number.
- (4) The final result of the calculation shall be expressed in the units of the standard.

Control Devices: In accordance with 20.2.72.203.A(3) and (8) NMAC, 20.2.70.300.D(5)(b) and (e) NMAC, and 20.2.73.200.B(7) NMAC, the permittee shall report all control devices and list each pollutant controlled by the control device

regardless if the applicant takes credit for the reduction in emissions. The applicant can indicate in this section of the application if they chose to not take credit for the reduction in emission rates. For notices of intent submitted under 20.2.73 NMAC, only uncontrolled emission rates can be considered to determine applicability unless the state or federal Acts require the control. This information is necessary to determine if federally enforceable conditions are necessary for the control device, and/or if the control device produces its own regulated pollutants or increases emission rates of other pollutants.

Calculations are provided.

Section 6.a

Green House Gas Emissions

(Submitting under 20.2.70, 20.2.72 20.2.74 NMAC)

Title V (20.2.70 NMAC), Minor NSR (20.2.72 NMAC), and PSD (20.2.74 NMAC) applicants must estimate and report greenhouse gas (GHG) emissions to verify the emission rates reported in the public notice, determine applicability to 40 CFR 60 Subparts, and to evaluate Prevention of Significant Deterioration (PSD) applicability. GHG emissions that are subject to air permit regulations consist of the sum of an aggregate group of these six greenhouse gases: carbon dioxide (CO₂), nitrous oxide (N₂O), methane (CH₄), hydrofluorocarbons (HFCs), perfluorocarbons (PFCs), and sulfur hexafluoride (SF₆).

Calculating GHG Emissions:

1. Calculate the ton per year (tpy) GHG mass emissions and GHG CO₂e emissions from your facility.
2. GHG mass emissions are the sum of the total annual tons of greenhouse gases without adjusting with the global warming potentials (GWPs). GHG CO₂e emissions are the sum of the mass emissions of each individual GHG multiplied by its GWP found in Table A-1 in 40 CFR 98 Mandatory Greenhouse Gas Reporting.
3. Emissions from routine or predictable start up, shut down, and maintenance must be included.
4. Report GHG mass and GHG CO₂e emissions in Table 2-P of this application. Emissions are reported in **short** tons per year and represent each emission unit's Potential to Emit (PTE).
5. All Title V major sources, PSD major sources, and all power plants, whether major or not, must calculate and report GHG mass and CO₂e emissions for each unit in Table 2-P.
6. For minor source facilities that are not power plants, are not Title V, and are not PSD there are three options for reporting GHGs in Table 2-P: 1) report GHGs for each individual piece of equipment; 2) report all GHGs from a group of unit types, for example report all combustion source GHGs as a single unit and all venting GHGs as a second separate unit; 3) or check the following By checking this box, the applicant acknowledges the total CO₂e emissions are less than 75,000 tons per year.

Sources for Calculating GHG Emissions:

- Manufacturer's Data
- AP-42 Compilation of Air Pollutant Emission Factors at <http://www.epa.gov/ttn/chief/ap42/index.html>
- EPA's Internet emission factor database WebFIRE at <http://cfpub.epa.gov/webfire/>
- 40 CFR 98 Mandatory Green House Gas Reporting except that tons should be reported in short tons rather than in metric tons for the purpose of PSD applicability.
- API Compendium of Greenhouse Gas Emissions Methodologies for the Oil and Natural Gas Industry. August 2009 or most recent version.
- Sources listed on EPA's NSR Resources for Estimating GHG Emissions at <http://www.epa.gov/nsr/clean-air-act-permitting-greenhouse-gases>:

Global Warming Potentials (GWP):

Applicants must use the Global Warming Potentials codified in Table A-1 of the most recent version of 40 CFR 98 Mandatory Greenhouse Gas Reporting. The GWP for a particular GHG is the ratio of heat trapped by one unit mass of the GHG to that of one unit mass of CO₂ over a specified time period.

"Greenhouse gas" for the purpose of air permit regulations is defined as the aggregate group of the following six gases: carbon dioxide, nitrous oxide, methane, hydrofluorocarbons, perfluorocarbons, and sulfur hexafluoride. **(20.2.70.7 NMAC, 20.2.74.7 NMAC)**. You may also find GHGs defined in 40 CFR 86.1818-12(a).

Metric to Short Ton Conversion:

Short tons for GHGs and other regulated pollutants are the standard unit of measure for PSD and title V permitting programs. 40 CFR 98 Mandatory Greenhouse Reporting requires metric tons.

1 metric ton = 1.10231 short tons (per Table A-2 to Subpart A of Part 98 – Units of Measure Conversions)

CONOCOPHILLIPS COMPANY
EAST VACUUM/LIQUIDS RECOVERY PLANT
FACILITY EMISSIONS SUMMARY

SOURCE DESCRIPTION	UNIT NUMBER	STACK NUMBER	NOx		CO		VOC (INCLUDES HAPs)		SO ₂		PM _{10 & 2.5}		HAPs		CO _{2e}
			lb/hr	TPY	lb/hr	TPY	lb/hr	TPY	lb/hr	TPY	lb/hr	TPY	lb/hr	TPY	TPY
SOLAR T1202 TURBINE	1	1	3.30	14.44	4.61	20.18	0.56	2.45	0.20	0.88	0.08	0.37	0.01	0.04	6,542
SOLAR T1202 TURBINE	2	2	3.30	14.44	4.61	20.18	0.56	2.45	0.20	0.88	0.08	0.37	0.01	0.04	6,542
SOLAR T1202 TURBINE	3	3	3.30	14.44	4.61	20.18	0.56	2.45	0.20	0.88	0.08	0.37	0.01	0.04	6,542
SOLAR T1202 TURBINE	4	4	3.30	14.44	4.61	20.18	0.56	2.45	0.20	0.88	0.08	0.37	0.01	0.04	6,542
HOT OIL HEATER	7	7	1.66	7.26	1.39	6.10	0.09	0.40	0.22	0.98	0.13	0.55	0.03	0.13	7,695
WAUKESHA L7042 GU	16	16	2.53	11.10	3.90	17.08	0.16	0.71	0.07	0.29	0.04	0.20	0.12	0.53	2,298
WAUKESHA L7042 GU	17	17	2.53	11.10	3.90	17.08	0.16	0.71	0.07	0.29	0.04	0.20	0.12	0.53	2,298
FLARES 19 AND 23: PILOT EMISSIONS ⁴	19/23	19/23	0.01	0.06	0.11	0.50	0.00	0.00	0.00	0.00	0.00	0.00	0.00	0.00	57
FLARES 19 AND 23: FLARING EMISSIONS	19/23	19/23	8.29	2.23	71.10	19.09	54.12	11.63	990.65	212.83	---	---	1.12	0.46	10,188
FLARE 22: PILOT EMISSIONS	22	22	0.01	0.00	0.01	0.00	0.00	0.00	0.00	0.00	0.00	0.00	0.00	-	86
FLARE 22: FLARING EMISSIONS ⁴	22	22	0.50	0.30	2.90	1.60	5.50	3.00	51.80	28.00	---	---	2.84	0.15	2,012
TRIETHYLENE GLYCOL DEHYDRATOR ²	DEHY1	DEHY1	Emissions are routed back to the inlet of the system.												
TRIETHYLENE GLYCOL DEHYDRATOR ²	DEHY2	DEHY2	Emissions are routed back to the inlet of the system.												
GLYCOL REGENERATOR (1.5 MMBTU/HR)	24	24	0.17	0.73	0.14	0.61	0.01	0.04	0.02	0.10	0.01	0.06	0.00	0.01	769
INLET SKIM TANK	T-11	T-11	Emissions are controlled using a redundant VRU system. During plant turnarounds, any emissions would be routed to Flare Unit 22.												
OVERFLOW TANK	T-12	T-12	Emissions are controlled using a redundant VRU system. During plant turnarounds, any emissions would be routed to Flare Unit 22.												
OIL SALES TANK	T-13	T-13	Emissions are controlled using a redundant VRU system. During plant turnarounds, any emissions would be routed to Flare Unit 22.												
OIL SURGE TANK	T-14	T-14	Emissions are controlled using a redundant VRU system. During plant turnarounds, any emissions would be routed to Flare Unit 22.												
PRODUCED WATER TANK	T-15	T-15	Emissions are controlled using a redundant VRU system. During plant turnarounds, any emissions would be routed to Flare Unit 22.												
FUGITIVE EMISSIONS: EQUIPMENT LEAKS AT PLANT	FUG1	FUG1	---	---	---	---	12.20	53.60	---	---	---	---	---	7.70	---
FUGITIVE EMISSIONS: EQUIPMENT LEAKS AT TANK BATTERY	FUG2	FUG2	---	---	---	---	0.10	0.40	---	---	---	---	---	0.00	---
TOTAL FACILITY EMISSIONS ³			NOx		CO		VOC (INCLUDES HAPs)		SO ₂		PM _{10 & 2.5}		HAPs		CO _{2e}
			lb/hr	TPY	lb/hr	TPY	lb/hr	TPY	lb/hr	TPY	lb/hr	TPY	lb/hr	TPY	TPY
			28.4	90.6	99.0	142.8	69.1	80.3	991.8	246.0	0.6	2.5	1.4	9.7	51,572

1 A "---" symbol indicates the pollutant is not emitted.

2 The dehydrators are closed loop systems.

3 The total NOx, CO, VOC, SO₂, and HAP hourly values do not include Unit 22 since it cannot be used at the same time as Units 19/23.

4 The pilot emissions for 19/23 and all emission rates for Unit 22 were obtained from NSR permit 218-M9R1.

CONOCOPHILLIPS COMPANY
EAST VACUUM/LIQUIDS RECOVERY PLANT
UNCONTROLLED FACILITY EMISSIONS SUMMARY

SOURCE DESCRIPTION	EMISSION UNIT NUMBER	STACK NUMBER	NOx		CO		VOC (INCLUDES HAPs)		SO ₂		PM _{10 & 2.5}		HAPs	
			lb/hr	TPY	lb/hr	TPY	lb/hr	TPY	lb/hr	TPY	lb/hr	TPY	lb/hr	TPY
SOLAR T1202 TURBINE	1	1	3.30	14.44	4.61	20.18	0.56	2.45	0.20	0.88	0.08	0.37	0.01	0.04
SOLAR T1202 TURBINE	2	2	3.30	14.44	4.61	20.18	0.56	2.45	0.20	0.88	0.08	0.37	0.01	0.04
SOLAR T1202 TURBINE	3	3	3.30	14.44	4.61	20.18	0.56	2.45	0.20	0.88	0.08	0.37	0.01	0.04
SOLAR T1202 TURBINE	4	4	3.30	14.44	4.61	20.18	0.56	2.45	0.20	0.88	0.08	0.37	0.01	0.04
HOT OIL HEATER	7	7	1.66	7.26	1.39	6.10	0.09	0.40	0.22	0.98	0.13	0.55	0.03	0.13
WAUKESHA L7042 GU	16	16	23.39	102.45	36.39	159.37	0.39	1.71	0.07	0.29	0.04	0.20	0.24	1.06
WAUKESHA L7042 GU	17	17	23.39	102.45	36.39	159.37	0.39	1.71	0.07	0.29	0.04	0.20	0.24	1.06
FLARES 19 AND 23: COMBINED EMISSION RATE	19/23	19/23	---	---	---	---	2705.79	6172.57	---	---	---	---	55.92	23.07
FLARE 22	22	22	---	---	---	---	808.34	3540.51	---	---	---	---	2.84	0.15
TRIETHYLENE GLYCOL DEHYDRATOR ²	DEHY1	DEHY1	Closed Loop System											
TRIETHYLENE GLYCOL DEHYDRATOR ²	DEHY2	DEHY2	Closed Loop System											
GLYCOL REGENERATOR (1.5 MMBTU/HR)	24	24	0.17	0.73	0.14	0.61	0.01	0.04	0.02	0.10	0.01	0.06	---	---
INLET SKIM TANK	T-11	T-11	---	---	---	---	90.76	397.51	---	---	---	---	16.88	73.94
OVERFLOW TANK	T-12	T-12	---	---	---	---	54.21	237.45	---	---	---	---	1.42	6.24
OIL SALES TANK	T-13	T-13	---	---	---	---	369.56	1618.67	---	---	---	---	10.18	44.61
OIL SURGE TANK	T-14	T-14	---	---	---	---	401.83	1760.00	---	---	---	---	11.04	48.37
PRODUCED WATER TANK	T-15	T-15	---	---	---	---	10.28	45.01	---	---	---	---	8.77	38.41
FUGITIVE EMISSIONS: EQUIPMENT LEAKS AT PLANT	FUG1	FUG1	---	---	---	---	12.20	53.60	---	---	---	---	---	7.70
FUGITIVE EMISSIONS: EQUIPMENT LEAKS AT TANK BATTERY	FUG2	FUG2	---	---	---	---	0.10	0.40	---	---	---	---	---	0.00
TOTAL FACILITY EMISSIONS			NOx		CO		VOC (INCLUDES HAPs)		SO ₂		PM _{10 & 2.5}		HAPs	
			lb/hr	TPY	lb/hr	TPY	lb/hr	TPY	lb/hr	TPY	lb/hr	TPY	lb/hr	TPY
			61.8	270.7	92.7	406.2	3647.8	13839.4	1.2	5.2	0.6	2.5	107.6	244.9

1 A "—" symbol indicates the pollutant is not emitted.

2 The dehydrators are closed loop systems.

3 The total NOx, CO, VOC, SO₂, and HAP hourly values do not include Unit 22 since it cannot be used at the same time as Units 19/23.

CONOCOPHILLIPS COMPANY
EAST VACUUM/LIQUIDS RECOVERY PLANT
TURBINE EMISSIONS

Emission Units:	1-4	
Source Description:	Natural gas turbine	
Manufacturer:	Solar	
Model:	T1202	
	Maximum Rating	
	<u>100%</u>	
Rated hp	1160	Manufacturer
Heat Rate	10998	Manufacturer, Btu/hp-hr
Fuel heat value	905	Nominal pipeline natural gas, HHV
Heat Input	12.8	Heat Rate * hp (MMBtu/hr)
Fuel consumption	14.1	Heat input / fuel heat value (mscf/hr)
Annual fuel usage	123.5	8760 hrs/yr operation (MMscf/yr)

Exhaust Parameters

Exhaust temp	818	Manufacturer
Stack diameter	1.50	Site
Stack height	16	Site
Exhaust flow	29,741	Calculated in 2009 NSR application, cfm
Stack velocity	280.5	Exhaust flow / stack area, cfs

Emission Calculations

Maximum Uncontrolled Emissions

	NOx ¹	CO ¹	VOC ¹	SO ₂ ²	PM ³	CH ₂ O	
	0.235	0.26	0.0399	14.29	6.60E-03	7.10E-04	lb/MMscf or lb/MMBtu
	10%	40%	10%				safety factor
	3.3	4.6	0.6	0.2	0.08	0.01	lb/hr
	14.4	20.2	2.5	0.9	0.37	0.04	tpy 8760 hrs/yr

Maximum Controlled Emissions

	NOx ¹	CO ¹	VOC ¹	SO ₂ ²	PM ³	CH ₂ O	
	3.3	4.6	0.6	0.2	0.08	0.01	Nominal % reduction lb/hr
	14.4	20.2	2.5	0.9	0.37	0.04	tpy 8760 hrs/yr

<i>GHG Emissions</i>	CO ₂ ⁴	CH ₄ ⁴	CH ₄ as CO ₂ e ⁴	N ₂ O ⁴	N ₂ O as CO ₂ e ⁴	CO ₂ e ⁴	
		117.0	0.0022		0.0002		
	1492.6	0.03	0.06	0.00	0.84	1493.5	lb/hr
	6537.6	0.12	0.70	0.01	3.67	6542.0	tpy 8760 hrs/yr

¹ Manufacturer specifications plus operational flexibility factors

² Based on 5 gr S/ 100 scf

³ AP-42, Table 3.1-2a

⁴ 40 CFR 98 Emission Factors

CONOCOPHILLIPS COMPANY
EAST VACUUM/LIQUIDS RECOVERY PLANT
HOT OIL HEATER EMISSIONS

Emission Unit: 7
Source Description: Hot oil heater

Fuel Data

Input heat rate 15.0 MMBtu/hr
Fuel heat value 905 Btu/scf
Fuel rate 16.6 Mscf/hr Heat rate / fuel heat value * 1000
Annual fuel usage 145.2 MMsfc/yr Assumes 8760 hrs/yr operation

Exhaust Parameters

Exhaust temp (Ta) 850 °F As permitted
Stack height 40 ft Measured
Stack diameter 2 ft Measured
Fuel F factor 10610 wscf/MMBtu 40 CFR 60 Appendix A Method 19
Exhaust flow (Vs) 2652.5 scfm Heat input*F factor/60
Exhaust flow (Va) 7721 acfm Va = Vs*(Ps/Pa)*(Ta/Ts)
Exhaust velocity 41.0 ft/sec Exhaust flow / stack area

Site Data

Site Elevation 3940 ft MSL
Standard Pressure (Ps) 29.92 in Hg
Pressure at Elevation (Pa) 25.90 in Hg Hess, Introduction to Theoretical Meteorology, eqn. 6.8
Standard Temperature (Ts) 520 R

Emission Rates

Uncontrolled/Controlled Emissions

NOx ¹	CO ¹	VOC ¹	SO ₂ ²	PM ¹	Units	
100	84	5.5		7.6	lb/MMscf	AP-42 Tables 1.4-1 & 2 based on 5 grains S /100 scf 8760 hrs/yr
1.7	1.4	0.1	0.22	0.1	lb/hr	
7.3	6.1	0.4	1.0	0.6	tpy	
Hexane¹						
1.80					lb/MMscf	AP-42 Table 1.4-1 & 2 8760 hrs/yr
0.03					lb/hr	
0.13					tpy	

GHG Emissions	CO ₂ ³	CH ₄ ³	CH ₄ as CO ₂ e ³	N ₂ O CO ₂ e ³	N ₂ O as CO ₂ e ³	CO ₂ e ³	
		117.0	0.0022		0.000221		
	1755.0	0.03	0.83	0.00	0.99	1756.8	lb/hr
	7686.7	0.14	3.62	0.01	4.32	7694.7	tpy

¹ USEPA AP-42, Section 1.4-1 and 2

² 5 gr S/100 scf. SO₂ calculation assumes 100% conversion of fuel elemental sulfur to SO₂.

³ 40 CFR 98 Emission Factors

CONOCOPHILLIPS COMPANY
EAST VACUUM/LIQUIDS RECOVERY PLANT
ENGINE (UNITS 16 & 17) EMISSIONS

Emission Units: 16 and 17
Source Description: Natural gas reciprocating engine
Manufacturer: Waukesha
Model: L7042 GU
Type: Four-stroke, rich burn naturally-aspirated engine

Sea level hp 636 hp Manufacturer
Elevation 3940 msl
Derate 7.3% 3% per 1000 ft over 1500 ft
Site hp 589 hp

Fuel Consumption

Heat Rate 7600 Btu/hp-hr Mfg data
Fuel heat value 905 Btu/scf
Heat Input 4.5 MMBtu/hr Heat Rate * hp
Fuel consumption 5.0 Mscf/hr Heat input / fuel heat value
Annual fuel usage 43.4 MMcf/yr 8760 hrs/yr operation

Exhaust Parameters

Exhaust temp 920 deg F As permitted
Stack diameter 0.83 ft As permitted
Stack height 40 ft As permitted
Stack flow 2435 acfm As permitted
Stack velocity 75.0 ft/s As permitted

Emission Calculations

Uncontrolled Emissions

NOx ¹	CO ¹	VOC ¹	SO ₂ ²	PM ³	CH ₂ O	n-Hexane	
18	28	0.3					g/hp-hr Mfg data
				9.99E-03	5.28E-02	1.11E-03	lb/MMBtu
23.4	36.4	0.4	0.07	0.04	0.24	0.00	lb/hr Hourly emission rate
102.5	159.4	1.7	0.29	0.20	1.04	0.02	tpy 8760 hrs/yr

Controlled Emissions

NOx ¹	CO ¹	VOC ¹	SO ₂ ²	PM ³	CH ₂ O	n-Hexane	
15.0	15.0	0.25					g/hp-hr Mfg data
87%	80%	50%			50%	50%	Control efficiency
2.0	3	0.13					g/hp-hr Catalyst controlled unit emissions
2.5	3.9	0.2	0.07	0.04	0.12	0.00	lb/hr Hourly emission rate
11.1	17.1	0.7	0.29	0.20	0.52	0.01	tpy 8760 hrs/yr

GHG Emissions	CH ₄ as		N ₂ O as		CO ₂ e ⁴	CO ₂ e ⁴	lb/MMBtu
	CO ₂ ⁴	CH ₄ ⁴	CO ₂ e ⁴	N ₂ O ⁴			
	117.0	0.0022		0.0002			
	524.1	0.01	0.25	0.00	0.29	524.7	lb/hr
	2295.7	0.04	1.08	0.00	1.29	2298.0	tpy

¹ Manufacturer specifications plus operational flexibility factors

² Based on 5 gr S/ 100 scf

³ USEPA AP-42, Section 3.2-2

⁴ 40 CFR 98 Emission Factors

CONOCOPHILLIPS COMPANY
EAST VACUUM/LIQUIDS RECOVERY PLANT
FLARE (UNITS 19 & 23) HOURLY LIMIT BASIS

Flare Gas Composition

Flow Rate: 0.40 MMscf 3 hour average
400 Mscf MMscf/d * 1000
400 Mscf/hr Mcf/hr over 3 hours
323.4 MMBtu/hr Sample taken 10/24/19
129.36 MMBtu/hr scfh * mixture heating value / 1000

Produced Gas Composition (based on a 10/24/19 gas analysis, then normalized for 1.5% H2S):

Component	MW	Mol %	Normalized Mol%	MW * Mol %	Mass Fraction
Water	18.02	0.000%			
Nitrogen	28.01	2.230%	2.21%	0.620	1.53%
CO ₂	44.01	77.551%	77.02%	33.896	83.58%
H₂S	34.08	1.500%	1.49%	0.508	1.25%
Methane	16.04	11.296%	11.22%	1.800	4.44%
Ethane	30.07	3.757%	3.73%	1.122	2.77%
Propane	44.10	2.058%	2.04%	0.901	2.22%
I-Butane	58.12	0.275%	0.27%	0.159	0.39%
N-Butane	58.12	0.760%	0.75%	0.439	1.08%
I-Pentane	72.15	0.254%	0.25%	0.182	0.45%
N-Pentane	72.15	0.306%	0.30%	0.219	0.54%
Hexanes	86.18	0.311%	0.31%	0.266	0.66%
n-hexane	86.18	0.064%	0.06%	0.054	0.13%
Benzene	78.11	0.029%	0.03%	0.022	0.06%
Heptanes	100.21	0.085%	0.08%	0.085	0.21%
Toluene	92.14	0.021%	0.02%	0.019	0.05%
Octanes	114.23	0.030%	0.03%	0.034	0.08%
Ethylbenzene	106.17	0.002%	0.00%	0.002	0.01%
Xylenes	106.17	0.005%	0.00%	0.005	0.01%
Nonanes	128.26	0.039%	0.04%	0.050	0.12%
C10+	142.29	0.120%	0.12%	0.170	0.42%
Total		100.7%	100%	40.55	100.00%

NMEHC (VOC) MOL % 4.36% NMEHC (VOC) WT. % 6.43%

Fuel Data

Flare Pilot and Purge 110 scf/hr Engineering estimate
0.11 Mscf/hr
986 Btu/scf Analysis
108.5 MBtu/hr Pilot heat input Btu/scf * dscf/hr / 1000
0.11 MMBtu/hr MBtu/hr / 1000

Flaring

400000 scf/hr Hourly volumetric throughput
129.4 MMBtu/hr Max total hourly plant throughput (dry)
13.8 MMscf/yr Annual volume
825.0 equivalent hrs for annual calculation

NOTE: Not a limit; used only to estimate annual emissions at maximum H2S concentration

Total

129.5 MMBtu/hr Pilot + Flare

CONOCOPHILLIPS COMPANY
EAST VACUUM/LIQUIDS RECOVERY PLANT
FLARE (UNITS 19 & 23) HOURLY LIMIT BASIS

Flare Emissions Calculations

Emission Rates

Flaring

	NOx	CO	VOC	H₂S	SO₂	Units	
	0.0641	0.5496				lb/MMBtu	TNRCC RG-109 (< 1000 Btu factors)
			6.43%	1.25%		wt%	
	8.29	71.10				lb/hr	lb/MMBtu * MMBtu/hr
			2705.79	526.9		lb/hr	Uncontrolled emissions
			11851.34	2308.0		tpy	Uncontrolled emissions
<i>total</i>	8.3	71.1	54.1	10.5	990.6	lb/hr	98% H ₂ S and VOC; 100% conversion to SO ₂
<i>Requested Flaring Limit</i>	8.3	71.1	54.1	10.5	990.6	lb/hr	

CONOCOPHILLIPS COMPANY
EAST VACUUM/LIQUIDS RECOVERY PLANT
FLARE (UNITS 19 & 23) ANNUAL LIMIT BASIS

Flare Gas Composition

Flow Rate: 5.00 MMscf/d Daily (Current Permit Limit)
5,000 Mscf/d MMscf/d * 1000
208 Mscf/hr Mcf/d / 24
323.4 Btu/sch Sample taken 10/24/19
67.38 MMBtu/hr scfh * mixture heating value / 1000

Produced Gas Composition (based on a 10/24/19 gas analysis, then normalized for 1.5% H2S):

Component	MW	Mol %	Normalized Mol%	MW * Mol %	Mass Fraction
Water	18.02	0.000%			
Nitrogen	28.01	2.230%	2.21%	0.620	1.53%
CO ₂	44.01	77.551%	77.02%	33.896	83.58%
H₂S	34.08	1.500%	1.49%	0.508	1.25%
Methane	16.04	11.296%	11.22%	1.800	4.44%
Ethane	30.07	3.757%	3.73%	1.122	2.77%
Propane	44.10	2.058%	2.04%	0.901	2.22%
I-Butane	58.12	0.275%	0.27%	0.159	0.39%
N-Butane	58.12	0.760%	0.75%	0.439	1.08%
I-Pentane	72.15	0.254%	0.25%	0.182	0.45%
N-Pentane	72.15	0.306%	0.30%	0.219	0.54%
Hexanes	86.18	0.311%	0.31%	0.266	0.66%
n-hexane	86.18	0.064%	0.06%	0.054	0.13%
Benzene	78.11	0.029%	0.03%	0.022	0.06%
Heptanes	100.21	0.085%	0.08%	0.085	0.21%
Toluene	92.14	0.021%	0.02%	0.019	0.05%
Octanes	114.23	0.030%	0.03%	0.034	0.08%
Ethylbenzene	106.17	0.002%	0.00%	0.002	0.01%
Xylenes	106.17	0.005%	0.00%	0.005	0.01%
Nonanes	128.26	0.039%	0.04%	0.050	0.12%
C10+	142.29	0.120%	0.12%	0.170	0.42%
Total		100.7%	100%	40.55	100.00%

NMEHC (VOC) MOL % 4.36% NMEHC (VOC) WT. % 6.43%

Fuel Data

Flare Pilot and Purge 110 scf/hr Engineering estimate
0.11 Mscf/hr
986 Btu/scf Analysis
108.5 MBtu/hr Pilot heat input Btu/scf * dscf/hr / 1000
0.11 MMBtu/hr MBtu/hr / 1000

Flaring

208333 scf/hr Hourly volumetric throughput
67.4 MMBtu/hr Max total hourly plant throughput (dry)
171.9 MMscf/yr Annual volume
825.0 equivalent hrs for annual calculation

NOTE: Not a limit; used only to estimate annual emissions at maximum H2S concentration

Total

67.5 MMBtu/hr Pilot + Flare

CONOCOPHILLIPS COMPANY
EAST VACUUM/LIQUIDS RECOVERY PLANT
FLARE (UNITS 19 & 23) ANNUAL LIMIT BASIS

Flare Emissions Calculations

Emission Rates

Pilot

NOx	CO	VOC	H₂S	SO₂	Units	
0.0641	0.5496				lb/MMBtu	TNRCC RG-109 (< 1000 Btu factors)
			4E-04		lb H ₂ S/Mscf	Purchased fuel (0.25 gr/100scf)
			4E-05		lb H ₂ S/hr	H ₂ S rate * fuel usage
				7E-03	lb S/Mscf	Purchased fuel, 5 gr S/100scf
				8E-04	lb SO ₂ /hr*	SO ₂ rate * fuel usage
		0.14%			Wt%	Purchased fuel analysis
0.01	0.06				lb/hr	lb/MMBtu * MMBtu/hr
		0.00	0.00	0.00	lb/hr	98% H ₂ S; 100% conversion to SO ₂
0.03	0.26	0.00	0.00	0.00	tpy	8760 hrs/yr

Flaring

NOx	CO	VOC	H₂S	SO₂	Units		
0.0641	0.5496				lb/MMBtu	TNRCC RG-109 (< 1000 Btu factors)	
		6.43%	1.25%		wt%		
4.32	37.03				lb/hr	lb/MMBtu * MMBtu/hr	
		1409.26	274.5		lb/hr	Uncontrolled emissions	
		6172.57	1202.1		tpy	Uncontrolled emissions	
<i>total</i>	4.32	37.03	28.19	5.49	515.96	lb/hr	98% H ₂ S and VOC; 100% conversion to SO ₂
	18.9	162.2	123.5	24.0	2259.9	tpy	lb/hr * 8760 hrs/yr
	1.8	15.3	11.6	2.3	212.8	tpy	Based on annual volume
	25%	25%	0%	0%	0%		Annual safety factor
Requested Flaring Limit	2.2	19.1	11.6	2.3	212.8	tpy	

CONOCOPHILLIPS COMPANY
EAST VACUUM/LIQUIDS RECOVERY PLANT
FLARE (UNITS 19 & 23) HAP EMISSIONS

Flare Hazardous Air Pollutant Emissions

Flare & Pilot Parameters

Emission Unit: Flares
 Source Description: Units 19 and 23

Pilot Flow Rate: 110.00 scf/hr Engineering Estimate
 0.11 Mscf/hr
 986.10 Btu/scf Analysis
 108.5 MBtu/hr Pilot heat input Btu/scf * dscf/hr / 1000
 0.11 MMBtu/hr
 0.96 MMscf/yr
 8760.0 hrs pilot hours of operation

Flare Flow Rate: 208333 scf/hr (dry) volumetric throughput
 5 MMscf/day
 825 hrs flare hours of operation
 171.9 MMscf/yr
 323.40 Btu/scf

Total: 67.5 MMBtu/hr Pilot + Flare

HAP Emission Rates

	Wt %	Gas Molecular Weight lb/mol	Flare Volume scf/hr	Flare Volume scf/yr	Uncontrolled Emissions lb/hr	Uncontrolled Emissions tpy	Controlled Emissions @ 98% efficiency lb/hr	Controlled Emissions @ 98% efficiency tons/yr
n-Hexane	0.134%	40.553	208,333	171,875,000	29.38	12.12	0.59	0.24
Benzene	0.055%	40.553	208,333	171,875,000	12.16	5.02	0.24	0.10
Toluene	0.047%	40.553	208,333	171,875,000	10.39	4.28	0.21	0.09
Ethylbenzene	0.005%	40.553	208,333	171,875,000	1.14	0.47	0.02	0.01
Xylene	0.013%	40.553	208,333	171,875,000	2.85	1.18	0.06	0.02
					55.92	23.07	1.12	0.46

* Pollutant concentrations were obtained from the 10/24/2019 extended gas analysis. N-hexane was conservatively assumed to be 10% of hexane.

CONOCOPHILLIPS COMPANY
EAST VACUUM/LIQUIDS RECOVERY PLANT
UNITS 19 and 23- GHG EMISSIONS

1) $E_{a,CH_4} = V_a * X_{CH_4} * [(1-\eta)* Z_L + Z_U]$	=	2,162.00	SCF/Yr
$V_a = 963,600.00$			
$X_{CH_4} = 0.11$			
$N = 0.98$			
$Z_L = 1.00$			
$Z_U = 0.00$			
2) $E_{a,CO_2} \text{ (uncombusted)} = V_a * X_{CO_2}$	=	742,145.79	SCF/Yr
$V_a = 963,600.00$			
$X_{CO_2} = 0.7702$			
3) $E_{a,CO_2} \text{ (combusted)} = \Sigma (\eta * V_a * Y_j * R_j * Z_L)$			
$N = 0.98$			
$V_a = 963,600.00$			
$Y_j =$		$R_j =$	$E_{a,CO_2} =$
Methane	0.1122	1	105,938.20
Ethane	0.0373	2	70,469.16
Propane	0.0204	3	57,902.13
Butane	0.0103	4	38,826.50
Pentane +	0.0126	5	59,318.26
$Z_L = 1.00$			332,454.25 SCF/Yr
3) $E_{s,n} = E_{a,n} * (459.67 + T_a) * P_a$ $(459.67 + T_a) * P_s$			
$E_{a,n}(CH_4) = 2,162.00$	=	1,946.25	SCF/Yr
$E_{a,n}(CO_2) = 1,074,600.04$	=	967,362.43	SCF/Yr
$T_s = 60^\circ F$			
$T_a = 93.7^\circ F$	Roswell, AP-42		
$P_s = 13.28$			
$P_a = 12.73$	Roswell, AP-42		
4) $Mass_{s,i} = E_{s,i} * \rho_i * 10^3$			
$E_{s,i}(CH_4) = 1,946.25$			
$E_{s,i}(CO_2) = 967,362.43$			
$\rho_i(CH_4) = 0.0192$	kg/ft3	=	0.04 metric tons
$\rho_i(CO_2) = 0.0526$	kg/ft3	=	50.88 metric tons
5) $CO_2e = CO_2 + (CH_4 * GWP)$	short tons		CO_2e
$CO_2 = 50.88$	=	56.09	56.09
$CH_4 = 0.04$	=	0.04	1.03
$CH_4 GWP = 25$			57.12

CONOCOPHILLIPS COMPANY
EAST VACUUM/LIQUIDS RECOVERY PLANT
UNITS 19 and 23- GHG EMISSIONS

1) $E_{a,CH_4} = V_a * X_{CH_4} * [(1-\eta) * Z_L + Z_U]$	=	385,631.43	SCE/Yr
$V_a = 171,875,000.00$			
$X_{CH_4} = 0.11$			
$N = 0.98$			
$Z_L = 1.00$			
$Z_U = 0.00$			
2) $E_{a,CO_2} (uncombusted) = V_a * X_{CO_2}$	=	132,374,747.99	SCE/Yr
$V_a = 171,875,000.00$			
$X_{CO_2} = 0.7702$			
3) $E_{a,CO_2} (combusted) = \Sigma (\eta * V_a * Y_j * R_j * Z_L)$			
$N = 0.98$			
$V_a = 171,875,000.00$			
$Y_j =$		$R_j =$	$E_{a,CO_2} =$
Methane	0.1122	1	18,895,940.09
Ethane	0.0373	2	12,569,413.41
Propane	0.0204	3	10,327,862.44
Butane	0.0103	4	6,925,388.81
Pentane +	0.0126	5	10,580,455.13
$Z_L = 1.00$			59,299,059.88 SCE/Yr
3) $E_{s,n} = E_{a,n} * (459.67 + T_a) * P_a$ $(459.67 + T_a) * P_s$			
$E_{a,n}(CH_4) = 385,631.43$	=	347,148.10	SCE/Yr
$E_{a,n}(CO_2) = 191,673,807.87$	=	172,546,094.91	SCE/Yr
$T_s = 60^\circ F$			
$T_a = 93.7^\circ F$	Roswell, AP-42		
$P_s = 13.28$			
$P_a = 12.73$	Roswell, AP-42		
4) $Mass_{s,i} = E_{s,i} * \rho_i * 10^3$			
$E_{s,i}(CH_4) = 347,148.10$			
$E_{s,i}(CO_2) = 172,546,094.91$			
$\rho_i(CH_4) = 0.0192$	kg/ft3	=	6.67 metric tons
$\rho_i(CO_2) = 0.0526$	kg/ft3	=	9075.92 metric tons
5) $CO_2e = CO_2 + (CH_4 * GWP)$	short tons		CO_2e
$CO_2 = 9075.92$	=	10004.49	10004.49
$CH_4 = 6.67$	=	7.35	183.68
$CH_4 GWP = 25$			10188.17

* V_a is the estimated annual volume of gas burned in Flare 19.

**CONOCOPHILLIPS COMPANY
EAST VACUUM/LIQUIDS RECOVERY PLANT
GLYCOL REGENERATOR HEATER (UNIT 24)**

Emission Unit: 24
Source Description: Glycol Regeneration Heater

Fuel Data

Input heat rate 1.5 MMBtu/hr
Fuel heat value 905 Btu/scf
Fuel rate 1.7 Mscf/hr Heat rate / fuel heat value * 1000
Annual fuel usage 14.5 MMscf/yr Assumes 8760 hrs/yr operation

Exhaust Parameters

Exhaust temp (Ta) 850 °F As permitted
Stack height 10 ft As permitted
Stack diameter 0.83 ft As permitted
Fuel F factor 10610 wscf/MMBt 40 CFR 60 Appendix A Method 19
Exhaust flow (Vs) 265.3 scfm Heat input*F factor/60
Exhaust flow (Va) 772 acfm $V_a = V_s * (P_s/P_a) * (T_a/T_s)$
Exhaust velocity 23.8 ft/sec Exhaust flow / stack area

Site Data

Site Elevation 3940 ft MSL
Standard Pressure (Ps) 29.92 in Hg
Pressure at Elevation (Pa) 25.90 in Hg Hess, Introduction to Theoretical Meteorology, eqn. 6.8
Standard Temperature (Ts) 520 R

Emission Rates

Uncontrolled/Controlled Emissions

NO _x ¹	CO ¹	VOC ¹	SO ₂ ²	PM ¹	Units	
100	84	5.5		7.6	lb/MMscf	AP-42 Tables 1.4-1 & 2 based on 5 grains S /100 scf
0.17	0.14	0.01	0.02	0.01	lb/hr	
0.73	0.61	0.04	0.10	0.06	tpy	8760 hrs/yr

Hexane¹

1.80				lb/MMscf	AP-42 Table 1.4-1 & 2 8760 hrs/yr
0.00				lb/hr	
0.01				tpy	

GHG Emissions

CO ₂ ³	CH ₄ ³	CH ₄ as CO ₂ e ³	N ₂ O	N ₂ O as CO ₂ e ³	CO ₂ e ³	
117.0	0.0022		0.000221			lb/MMBtu
175.5	0.00	0.08	0.00	0.10	175.7	lb/hr
768.7	0.01	0.36	0.00	0.43	769.5	tpy

¹ USEPA AP-42, Section 1.4-1 and 2

² 5 gr S/100 scf. SO₂ calculation assumes 100% conversion of fuel elemental sulfur to SO₂.

³ 40 CFR 98 Emission Factors

CONOCOPHILLIPS COMPANY
EAST VACUUM/LIQUIDS RECOVERY PLANT
SKIM TANK (SKTK) - EMISSIONS SUMMARY

Component	Uncontrolled W&B Stream		Uncontrolled Flash Stream		Total Uncontrolled Stream		Stream Controlled By Redundant VRU	
	lb/hr	TPY	lb/hr	TPY	lb/hr	TPY	lb/hr	TPY
H2S	6.930	30.352	6.517	28.543	13.446	58.895	0.000	0.000
Nitrogen	0.060	0.262	3.603	15.780	3.662	16.042	0.000	0.000
Methane	0.511	2.238	14.951	65.486	15.462	67.724	0.000	0.000
CO2	724.796	3174.608	1087.220	4762.022	1812.016	7936.630	0.000	0.000
Ethane	0.377	1.651	7.723	33.828	8.100	35.479	0.000	0.000
Propane	1.102	4.827	31.517	138.044	32.619	142.871	0.000	0.000
Isobutane	0.115	0.505	4.668	20.444	4.783	20.949	0.000	0.000
n-Butane	0.406	1.778	11.571	50.683	11.977	52.460	0.000	0.000
Isopentane	0.062	0.270	2.023	8.862	2.085	9.132	0.000	0.000
n-Pentane	0.031	0.137	1.434	6.279	1.465	6.416	0.000	0.000
i-Hexane	0.088	0.384	2.245	9.835	2.333	10.219	0.000	0.000
n-Hexane	0.064	0.279	1.391	6.092	1.455	6.371	0.000	0.000
2,2,4-Trimethylpentane	0.005	0.021	0.053	0.232	0.058	0.253	0.000	0.000
Benzene	2.972	13.017	3.107	13.608	6.079	26.625	0.000	0.000
Heptane	0.645	2.823	5.889	25.794	6.534	28.617	0.000	0.000
Toluene	3.083	13.504	3.223	14.116	6.306	27.620	0.000	0.000
Octane	1.520	6.659	5.042	22.083	6.562	28.742	0.000	0.000
Ethylbenzene	1.005	4.404	1.110	4.864	2.116	9.268	0.000	0.000
o-Xylene	0.415	1.816	0.454	1.988	0.868	3.804	0.000	0.000
Nonane	2.473	10.832	3.021	13.231	5.494	24.062	0.000	0.000
Water	0.008	0.037	0.014	0.062	0.023	0.099	0.000	0.000
C10+ (Oil)	21.466	94.020	25.730	112.697	47.196	206.717	0.000	0.000

Component	Uncontrolled W&B Stream		Uncontrolled Flash Stream		Total Uncontrolled Stream		Stream Controlled By Redundant VRU	
	lb/hr	TPY	lb/hr	TPY	lb/hr	TPY	lb/hr	TPY
STREAM TOTAL	768.13	3364.42	1222.51	5354.57	1990.64	8718.99	0.00	0.00
VOC TOTAL	13.99	61.29	76.76	336.22	90.76	397.51	0.00	0.00
HAP TOTAL	7.54	33.04	9.34	40.90	16.88	73.94	0.00	0.00
H2S TOTAL	6.93	30.35	6.52	28.54	13.45	58.89	0.00	0.00

¹Uncontrolled emissions and gas volume are based on Promax Results. Tank vapors are controlled using a redundant VRU.

²Controlled Emissions Were Calculated by the Following: Uncontrolled Emissions * (1 - VRU Efficiency)

Redundant VRU Efficiency **100%**

Operating Time Hours 8760

³Annual controlled rate (tpy) calculated by multiplying hourly emission rate by 8760 hours.

CONOCOPHILLIPS COMPANY
EAST VACUUM/LIQUIDS RECOVERY PLANT
OVERFLOW OIL TANK (T42) - EMISSIONS SUMMARY

Component	Uncontrolled W&B Stream		Uncontrolled Flash Stream		Total Uncontrolled Stream		Stream Controlled By Redundant VRUs	
	lb/hr	TPY	lb/hr	TPY	lb/hr	TPY	lb/hr	TPY
H2S	0.054	0.238	0.111	0.486	0.165	0.724	0.000	0.000
Nitrogen	0.000	0.002	0.033	0.143	0.033	0.145	0.000	0.000
Methane	0.023	0.100	0.458	2.008	0.481	2.108	0.000	0.000
Carbon Dioxide	1.073	4.701	8.574	37.554	9.647	42.256	0.000	0.000
Ethane	0.323	1.416	1.142	5.002	1.465	6.418	0.000	0.000
Propane	7.958	34.858	16.025	70.190	23.984	105.048	0.000	0.000
i-Butane	2.039	8.931	4.538	19.875	6.577	28.805	0.000	0.000
n-Butane	4.176	18.290	9.329	40.861	13.505	59.151	0.000	0.000
i-Pentane	0.763	3.344	1.820	7.973	2.584	11.316	0.000	0.000
n-Pentane	0.649	2.843	1.557	6.820	2.206	9.663	0.000	0.000
i-Hexane	0.497	2.175	1.305	5.718	1.802	7.893	0.000	0.000
n-Hexane	0.252	1.103	0.642	2.813	0.894	3.916	0.000	0.000
2,2,4-Trimethylpentane	0.003	0.015	0.011	0.050	0.015	0.065	0.000	0.000
Benzene	0.049	0.214	0.150	0.657	0.199	0.871	0.000	0.000
Heptane	0.364	1.596	1.124	4.925	1.489	6.520	0.000	0.000
Toluene	0.054	0.238	0.167	0.731	0.221	0.968	0.000	0.000
Octane	0.106	0.463	0.397	1.737	0.502	2.200	0.000	0.000
Ethylbenzene	0.017	0.075	0.052	0.228	0.069	0.303	0.000	0.000
Xylene	0.006	0.026	0.020	0.089	0.026	0.115	0.000	0.000
Nonane	0.025	0.108	0.115	0.505	0.140	0.613	0.000	0.000
C10+	0.000	0.000	0.000	0.001	0.000	0.002	0.000	0.000
Water	0.000	0.001	0.209	0.915	0.209	0.915	0.000	0.000

Component	Uncontrolled W&B Stream		Uncontrolled Flash Stream		Total Uncontrolled Stream		Stream Controlled By Redundant VRUs	
	lb/hr	TPY	lb/hr	TPY	lb/hr	TPY	lb/hr	TPY
STREAM TOTAL	18.43	80.74	47.78	209.28	66.21	290.01	0.00	0.00
VOC TOTAL	16.96	74.28	37.25	163.17	54.21	237.45	0.00	0.00
HAP TOTAL	0.38	1.67	1.04	4.57	1.42	6.24	0.00	0.00
H2S TOTAL	0.05	0.24	0.11	0.49	0.17	0.72	0.00	0.00

¹Uncontrolled emissions and gas volume are based on Promax Results. Tank vapors are controlled using a redundant VRU.

²Controlled Emissions Were Calculated by the Following: Uncontrolled Emissions * (1 - VRU Efficiency)

Redundant VRU Efficiency **100%**

Operating Time Hours **8760**

³Annual controlled rate (tpy) calculated by multiplying hourly emission rate by 8760 hours.

CONOCOPHILLIPS COMPANY
EAST VACUUM/LIQUIDS RECOVERY PLANT
SALES OIL TANK (OT-SALES) - EMISSIONS SUMMARY

Component	Uncontrolled W&B Stream		Uncontrolled Flash Stream		Total Uncontrolled Stream		Stream Controlled By Redundant VRUs	
	lb/hr	TPY	lb/hr	TPY	lb/hr	TPY	lb/hr	TPY
H2S	0.096	0.421	1.015	4.445	1.111	4.866	0.000	0.000
Nitrogen	0.001	0.006	0.299	1.310	0.301	1.316	0.000	0.000
Methane	0.092	0.405	4.195	18.373	4.287	18.777	0.000	0.000
Carbon Dioxide	6.057	26.531	78.453	343.623	84.510	370.154	0.000	0.000
Ethane	1.113	4.874	10.450	45.772	11.563	50.646	0.000	0.000
Propane	13.487	59.073	146.630	642.238	160.117	701.312	0.000	0.000
i-Butane	3.449	15.106	41.519	181.853	44.968	196.959	0.000	0.000
n-Butane	7.058	30.915	85.360	373.877	92.418	404.792	0.000	0.000
i-Pentane	1.289	5.644	16.655	72.949	17.944	78.593	0.000	0.000
n-Pentane	1.095	4.797	14.247	62.400	15.342	67.197	0.000	0.000
i-Hexane	0.837	3.666	11.944	52.315	12.781	55.982	0.000	0.000
n-Hexane	0.424	1.859	5.877	25.741	6.301	27.600	0.000	0.000
2,2,4-Trimethylpentane	0.006	0.025	0.104	0.455	0.110	0.481	0.000	0.000
Benzene	0.082	0.360	1.372	6.011	1.455	6.371	0.000	0.000
Heptane	0.613	2.686	10.288	45.059	10.901	47.745	0.000	0.000
Toluene	0.091	0.400	1.526	6.684	1.617	7.084	0.000	0.000
Octane	0.178	0.778	3.628	15.892	3.806	16.670	0.000	0.000
Ethylbenzene	0.029	0.126	0.477	2.088	0.505	2.214	0.000	0.000
Xylene	0.010	0.044	0.185	0.812	0.196	0.857	0.000	0.000
Nonane	0.041	0.181	1.054	4.618	1.096	4.800	0.000	0.000
C10+	0.000	0.000	0.003	0.013	0.003	0.013	0.000	0.000
Water	0.000	0.001	1.911	8.368	1.911	8.369	0.000	0.000

Component	Uncontrolled W&B Stream		Uncontrolled Flash Stream		Total Uncontrolled Stream		Stream Controlled By Redundant VRUs	
	lb/hr	TPY	lb/hr	TPY	lb/hr	TPY	lb/hr	TPY
STREAM TOTAL	36.05	157.90	437.19	1914.90	473.24	2072.80	0.00	0.00
VOC TOTAL	28.69	125.66	340.87	1493.01	369.56	1618.67	0.00	0.00
HAP TOTAL	0.64	2.81	9.54	41.79	10.18	44.61	0.00	0.00
H2S TOTAL	0.10	0.42	1.01	4.44	1.11	4.87	0.00	0.00

¹Uncontrolled emissions and gas volume are based on Promax Results. Tank vapors are controlled using a redundant VRU.

²Controlled Emissions Were Calculated by the Following: Uncontrolled Emissions * (1 - VRU Efficiency)

Redundant VRU Efficiency **100%**

Operating Time	Hours	8760
----------------	-------	------

³Annual controlled rate (tpy) calculated by multiplying hourly emission rate by 8760 hours.

CONOCOPHILLIPS COMPANY
EAST VACUUM/LIQUIDS RECOVERY PLANT
SURGE OIL TANK (OT-SURGE) - EMISSIONS SUMMARY

Component	Uncontrolled W&B Stream		Uncontrolled Flash Stream		Total Uncontrolled Stream		Stream Controlled By Redundant VRUs	
	lb/hr	TPY	lb/hr	TPY	lb/hr	TPY	lb/hr	TPY
H2S	0.121	0.531	1.093	4.787	1.214	5.318	0.000	0.000
Nitrogen	0.002	0.008	0.322	1.411	0.324	1.418	0.000	0.000
Methane	0.115	0.506	4.515	19.776	4.631	20.282	0.000	0.000
Carbon Dioxide	7.619	33.373	84.528	370.231	92.147	403.604	0.000	0.000
Ethane	1.397	6.118	11.239	49.226	12.636	55.344	0.000	0.000
Propane	16.966	74.311	157.450	689.630	174.416	763.941	0.000	0.000
i-Butane	4.348	19.043	44.527	195.028	48.875	214.070	0.000	0.000
n-Butane	8.905	39.004	91.508	400.806	100.413	439.810	0.000	0.000
i-Pentane	1.629	7.135	17.843	78.153	19.472	85.288	0.000	0.000
n-Pentane	1.385	6.068	15.261	66.841	16.646	72.909	0.000	0.000
i-Hexane	1.060	4.645	12.794	56.038	13.854	60.682	0.000	0.000
n-Hexane	0.538	2.356	6.295	27.571	6.833	29.927	0.000	0.000
2,2,4-Trimethylpentane	0.007	0.032	0.111	0.488	0.119	0.520	0.000	0.000
Benzene	0.105	0.458	1.473	6.450	1.577	6.908	0.000	0.000
Heptane	0.779	3.412	11.023	48.281	11.802	51.693	0.000	0.000
Toluene	0.116	0.509	1.637	7.171	1.753	7.680	0.000	0.000
Octane	0.226	0.991	3.891	17.042	4.117	18.034	0.000	0.000
Ethylbenzene	0.037	0.160	0.512	2.241	0.548	2.401	0.000	0.000
Xylene	0.013	0.057	0.199	0.872	0.212	0.928	0.000	0.000
Nonane	0.053	0.231	1.132	4.960	1.185	5.191	0.000	0.000
C10+	0.000	0.001	0.003	0.014	0.003	0.014	0.000	0.000
Water	0.000	0.001	2.065	9.043	2.065	9.044	0.000	0.000

Component	Uncontrolled W&B Stream		Uncontrolled Flash Stream		Total Uncontrolled Stream		Stream Controlled By Redundant VRUs	
	lb/hr	TPY	lb/hr	TPY	lb/hr	TPY	lb/hr	TPY
STREAM TOTAL	45.42	198.95	469.42	2056.06	514.84	2255.01	0.00	0.00
VOC TOTAL	36.17	158.41	365.66	1601.59	401.83	1760.00	0.00	0.00
HAP TOTAL	0.82	3.57	10.23	44.79	11.04	48.37	0.00	0.00
H2S TOTAL	0.12	0.53	1.09	4.79	1.21	5.32	0.00	0.00

¹Uncontrolled emissions and gas volume are based on Promax Results. Tank vapors are controlled using a redundant VRU.

²Controlled Emissions Were Calculated by the Following: Uncontrolled Emissions * (1 - VRU Efficiency)

Redundant VRU Efficiency 100%

Operating Time	Hours	8760
----------------	-------	------

³Annual controlled rate (tpy) calculated by multiplying hourly emission rate by 8760 hours.

CONOCOPHILLIPS COMPANY
EAST VACUUM/LIQUIDS RECOVERY PLANT
PRODUCED WATER TANK (T15) - EMISSIONS SUMMARY

Component	Uncontrolled W&B Stream		Uncontrolled Flash Stream		Total Uncontrolled Stream		Stream Controlled By Redundant VRU	
	lb/hr	TPY	lb/hr	TPY	lb/hr	TPY	lb/hr	TPY
H2S	7.437	32.573	0.165	0.721	7.601	33.294	0.000	0.000
Nitrogen	0.018	0.077	0.038	0.166	0.056	0.244	0.000	0.000
Methane	0.240	1.050	0.226	0.989	0.466	2.039	0.000	0.000
Carbon Dioxide	704.818	3087.104	26.804	117.403	731.623	3204.507	0.000	0.000
Ethane	0.206	0.903	0.132	0.579	0.338	1.482	0.000	0.000
Propane	0.487	2.133	0.472	2.069	0.959	4.202	0.000	0.000
i-Butane	0.035	0.152	0.057	0.249	0.092	0.401	0.000	0.000
n-Butane	0.157	0.690	0.168	0.734	0.325	1.424	0.000	0.000
i-Pentane	0.014	0.062	0.024	0.106	0.038	0.167	0.000	0.000
n-Pentane	0.003	0.011	0.010	0.045	0.013	0.056	0.000	0.000
i-Hexane	0.006	0.027	0.019	0.085	0.025	0.112	0.000	0.000
n-Hexane	0.001	0.005	0.007	0.032	0.008	0.037	0.000	0.000
2,2,4-Trimethylpentane	0.000	0.000	0.000	0.001	0.000	0.001	0.000	0.000
Benzene	3.385	14.827	0.079	0.345	3.464	15.172	0.000	0.000
Heptane	0.002	0.010	0.023	0.102	0.026	0.112	0.000	0.000
Toluene	3.508	15.367	0.082	0.357	3.590	15.724	0.000	0.000
Octane	0.000	0.002	0.010	0.043	0.010	0.045	0.000	0.000
Ethylbenzene	1.180	5.166	0.028	0.123	1.208	5.289	0.000	0.000
Xylene	0.487	2.133	0.011	0.050	0.498	2.183	0.000	0.000
Nonane	0.000	0.001	0.005	0.022	0.005	0.023	0.000	0.000
C10+	0.014	0.060	0.000	0.002	0.014	0.061	0.000	0.000
Water	26.565	116.353	0.658	2.880	27.222	119.234	0.000	0.000

Component	Uncontrolled W&B Stream		Uncontrolled Flash Stream		Total Uncontrolled Stream		Stream Controlled By Redundant VRU	
	lb/hr	TPY	lb/hr	TPY	lb/hr	TPY	lb/hr	TPY
STREAM TOTAL	748.56	3278.71	29.02	127.10	777.58	3405.81	0.00	0.00
VOC TOTAL	9.28	40.64	1.00	4.36	10.28	45.01	0.00	0.00
HAP TOTAL	8.56	37.50	0.21	0.91	8.77	38.41	0.00	0.00
H2S TOTAL	7.44	32.57	0.16	0.72	7.60	33.29	0.00	0.00

¹Uncontrolled emissions and gas volume are based on Promax Results. Tank vapors are controlled using a redundant VRU.

²Controlled Emissions Were Calculated by the Following: Uncontrolled Emissions * (1 - VRU Efficiency)

Redundant VRU Efficiency 100%

Operating Time	Hours	8760
----------------	-------	------

³Annual controlled rate (tpy) calculated by multiplying hourly emission rate by 8760 hours.

CONOCOPHILLIPS COMPANY
EAST VACUUM/LIQUIDS RECOVERY PLANT
STANDBY ENGINE TO POWER AIR COMPRESSOR (ACENG) EMISSIONS

Emission Units: ACENG
Source Description: Gasoline Engine (Standby Power for Air Compressor)
Manufacturer: Kohler
Model: CH 745S
Type: Four-stroke, rich burn naturally-aspirated engine

Sea level hp 28 hp Manufacturer
Hours of Operation 500 Hours/yr

Fuel Consumption

Heat Rate 12714 Btu/hp-hr Estimated
Fuel heat value 130000 Btu/gal
Fuel consumption 2.7 Gal/hr Heat Rate * hp
Annual Fuel Use 1369.2 Gal/yr

Exhaust Parameters

Exhaust temp 1150 deg F Site
Stack diameter 0.30 ft Manufacturer
Stack height 9.2 ft Site
Stack flow 170 acfm Manufacturer
Stack velocity 40.1 ft/s Manufacturer

Emission Calculations

Uncontrolled Emissions

NOx ¹	CO ¹	VOC ¹	SO ₂ ¹	PM ¹	CH ₂₀ ¹		
0.011	0.00696	0.015	0.000591	7.21E-04	4.85E-04	lb/hp-hr	AP-42, Table 3.3-1
0.31	0.19	0.42	0.02	0.02	0.01	lb/hr	Hourly emission rate
1.35	0.85	1.84	0.07	0.09	0.06	tpy	500 hrs/yr

Controlled Emissions

NOx ¹	CO ¹	VOC ¹	SO ₂ ²	PM ³	CH ₂₀		
0.31	0.19	0.42	0.02	0.02	0.01	lb/hr	Hourly emission rate
1.35	0.85	1.84	0.07	0.09	0.06	tpy	500 hrs/yr

¹ USEPA AP-42, Section 3.3-1

**CONOCOPHILLIPS COMPANY
EAST VACUUM/LIQUIDS RECOVERY PLANT
GLYCOL REGENERATOR HEATER (UNIT 6)**

Emission Unit: 6
Source Description: Glycol Regeneration Heater

Fuel Data

Input heat rate 0.5 MMBtu/hr
Fuel heat value 905 Btu/scf
Fuel rate 0.6 Mscf/hr Heat rate / fuel heat value * 1000
Annual fuel usage 4.8 MMscf/yr Assumes 8760 hrs/yr operation

Exhaust Parameters

Exhaust temp (Ta) 850 °F As permitted
Stack height 10 ft Measured
Stack diameter 1 ft Measured
Fuel F factor 10610 wscf/MMBtu 40 CFR 60 Appendix A Method 19
Exhaust flow (Vs) 88.4 scfm Heat input*F factor/60
Exhaust flow (Va) 257 acfm $V_a = V_s * (P_s/P_a) * (T_a/T_s)$
Exhaust velocity 5.5 ft/sec Exhaust flow / stack area

Site Data

Site Elevation 3940 ft MSL
Standard Pressure (Ps) 29.92 in Hg
Pressure at Elevation (Pa) 25.90 in Hg Hess, Introduction to Theoretical Meteorology, eqn. 6.8
Standard Temperature (Ts) 520 R

Emission Rates

Uncontrolled/Controlled Emissions

NO _x ¹	CO ¹	VOC ¹	SO ₂ ²	PM ¹	Units	
100	84	5.5		7.6	lb/MMscf	AP-42 Tables 1.4-1 & 2 based on 5 grains S /100 scf
0.06	0.05	0.00	0.01	0.00	lb/hr	
0.24	0.20	0.01	0.03	0.02	tpy	

Hexane¹

1.80				lb/MMscf	AP-42 Table 1.4-1 & 2
0.00				lb/hr	
0.00				tpy	

GHG Emissions

CO ₂ ³	CH ₄ ³	CH ₄ as CO ₂ e ³	N ₂ O	N ₂ O as CO ₂ e ³	CO ₂ e ³	
117.0	0.0022		0.000221			lb/MMBtu
58.5	0.00	0.03	0.00	0.03	58.6	lb/hr
256.2	0.00	0.12	0.00	0.14	256.5	tpy

¹ USEPA AP-42, Section 1.4-1 and 2

² 5 gr S/100 scf. SO₂ calculation assumes 100% conversion of fuel elemental sulfur to SO₂.

³ 40 CFR 98 Emission Factors

Tab 7
Section 7 - Information Used To Determine
Emissions

Section 7

Information Used To Determine Emissions

Information Used to Determine Emissions shall include the following:

- If manufacturer data are used, include specifications for emissions units and control equipment, including control efficiencies specifications and sufficient engineering data for verification of control equipment operation, including design drawings, test reports, and design parameters that affect normal operation.
 - If test data are used, include a copy of the complete test report. If the test data are for an emissions unit other than the one being permitted, the emission units must be identical. Test data may not be used if any difference in operating conditions of the unit being permitted and the unit represented in the test report significantly effect emission rates.
 - If the most current copy of AP-42 is used, reference the section and date located at the bottom of the page. Include a copy of the page containing the emissions factors, and clearly mark the factors used in the calculations.
 - If an older version of AP-42 is used, include a complete copy of the section.
 - If an EPA document or other material is referenced, include a complete copy.
 - Fuel specifications sheet.
 - If computer models are used to estimate emissions, include an input summary (if available) and a detailed report, and a disk containing the input file(s) used to run the model. For tank-flashing emissions, include a discussion of the method used to estimate tank-flashing emissions, relative thresholds (i.e., permit or major source (NSPS, PSD or Title V)), accuracy of the model, the input and output from simulation models and software, all calculations, documentation of any assumptions used, descriptions of sampling methods and conditions, copies of any lab sample analysis.
-

Backup documentation is provided. The oil and gas samples used for the Promax simulation were collected at the free water knockout, which is the first stage of separation at the inlet to the tank battery.



Oil Sample for
Promax
Certificate of Analysis
Number: 5030-20040927-001A

Midland Laboratory
2200 East I-20
Midland, TX 79706
Phone 432-689-7252

Andy Hartman
SPL-Artesia
200 E Main St
Artesia, NM 88210

Apr. 29, 2020

Station Name: EVG SAU CTB
Station Location: Buckeye
Sample Point: FWKO Oil Outlet
Cylinder No: 000904
Analyzed: 04/29/2020 11:53:40 by JS

Sampled By: DEREK SAUDER
Sample Of: Oil Spot
Sample Date: 04/28/2020 10:00
Sample Conditions: 31.7 psig, @ 70 °F
Method: GPA 2103M

Analytical Data

Components	Mol. %	MW	Wt. %	Sp. Gravity	L.V. %
Hydrogen Sulfide	NIL	NIL	NIL	NIL	NIL
Nitrogen	0.006	28.013	0.001	0.8069	0.001
Methane	0.031	16.043	0.003	0.3000	0.008
Carbon Dioxide	1.347	44.010	0.363	0.8172	0.361
Ethane	0.130	30.069	0.024	0.3563	0.055
Propane	1.944	44.096	0.525	0.5072	0.842
Iso-Butane	1.107	58.122	0.394	0.5628	0.569
n-Butane	3.610	58.122	1.285	0.5842	1.789
Iso-Pentane	1.711	72.149	0.756	0.6251	0.984
n-Pentane	2.028	72.149	0.896	0.6307	1.155
i-Hexanes	3.447	85.388	1.803	0.6661	2.201
n-Hexane	2.495	86.175	1.317	0.6641	1.613
2,2,4-Trimethylpentane	0.080	114.229	0.056	0.6964	0.065
Benzene	0.938	78.112	0.449	0.8844	0.413
Heptanes	10.330	100.202	6.340	0.6882	7.492
Toluene	2.748	92.138	1.551	0.8719	1.447
Octanes	9.299	114.229	6.506	0.7066	7.489
Ethylbenzene	2.222	106.165	1.445	0.8716	1.348
Xylenes	1.123	106.167	0.730	0.8761	0.678
Nonanes	7.245	128.255	5.691	0.7222	6.409
Decanes Plus	48.159	235.212	69.865	0.8505	65.081
	100.000		100.000		100.000

Calculated Physical Properties	Total	C10+
Specific Gravity at 60°F	0.8133	0.8505
API Gravity at 60°F	42.483	34.870
Molecular Weight	163.268	235.212
Pounds per Gallon (in Vacuum)	6.781	7.091
Pounds per Gallon (in Air)	6.773	7.083
Cu. Ft. Vapor per Gallon @ 14.696 psia	15.761	11.440

Hydrocarbon Laboratory Manager

Quality Assurance: The above analyses are performed in accordance with ASTM, UOP, GPA guidelines for quality assurance, unless otherwise stated.



Certificate of Analysis
 Number: 5030-20040927-001A

Midland Laboratory
 2200 East I-20
 Midland, TX 79706
 Phone 432-689-7252

Andy Hartman
 SPL-Artesia
 200 E Main St
 Artesia, NM 88210

Apr. 29, 2020

Station Name: EVG SAU CTB
 Station Location: Buckeye
 Sample Point: FWKO Oil Outlet
 Cylinder No: 000904

Sampled By: DEREK SAUDER
 Sample Of: Oil Spot
 Sample Date: 04/28/2020 10:00
 Sample Conditions: 31.7 psig, @ 70 °F

Analytical Data

Test	Method	Result	Units	Detection Limit	Lab Tech.	Analysis Date
API Gravity @ 60° F	ASTM D-5002	39.65	°		NF	04/29/2020
Specific Gravity @ 60/60° F	ASTM D-5002	0.8267			NF	04/29/2020
Density @ 60° F	ASTM D-5002	0.8259	g/ml		NF	04/29/2020
ASTM D323 RVPE @ 100° F	ASTM D-6377	13.06	psi		NF	04/29/2020
VP of Crude Oil: V/L = 4:1 @ 100 °F	ASTM D-6377	15.65	psi		NF	04/29/2020
Shrinkage Factor	API 20.1 M	0.9995			NF	04/29/2020
Flash Factor	API 20.1 M	38.1571	Cu.Ft./STBbl.		NF	04/29/2020
Color Visual	API 20.1 M	Dark Amber			NF	04/29/2020

Hydrocarbon Laboratory Manager

Quality Assurance: The above analyses are performed in accordance with ASTM, UOP, GPA guidelines for quality assurance, unless otherwise stated.



Gas Sample for
 Promax
 Certificate of Analysis
 Number: 6030-20040197-001A

Artesia Laboratory
 200 E Main St.
 Artesia, NM 88210
 Phone 575-746-3481

Myke Lane
 ConocoPhillips
 935 N. Eldridge Parkway
 Houston, TX 77079

Apr. 29, 2020

Station Name: EVG SAU CTB
 Station Number: FWKO
 Station Location: Conoco
 Sample Point: FWKO GAS OUTLET
 Analyzed: 04/28/2020 14:40:36 by User1

Sampled By: DEREK SAUDER
 Sample Of: Gas Spot
 Sample Date: 04/28/2020 10:15
 Sample Conditions: 32.1 psig, @ 70 °F
 Method: GPA 2286
 Cylinder No: 5030-01060

Analytical Data

Components	Mol. %	Wt. %	GPM at 14.73 psia	
Hydrogen Sulfide	0.923	0.683		GPM TOTAL C2+
Nitrogen	0.590	0.359		10.609
Methane	3.637	1.267		
Carbon Dioxide	60.460	57.767		
Ethane	1.588	1.037	0.429	
Propane	15.083	14.440	4.200	
Iso-Butane	4.027	5.082	1.332	
n-Butane	9.173	11.575	2.923	
Iso-Pentane	1.513	2.370	0.559	
n-Pentane	1.312	2.055	0.481	
i-Hexanes	0.535	0.982	0.215	
n-Hexane	0.243	0.463	0.103	
Benzene	0.067	0.114	0.019	
Cyclohexane	0.138	0.254	0.048	
i-Heptanes	0.322	0.644	0.129	
n-Heptane	0.060	0.131	0.028	
Toluene	0.064	0.127	0.021	
i-Octanes	0.156	0.357	0.069	
n-Octane	0.016	0.037	0.008	
Ethylbenzene	0.016	0.036	0.006	
Xylenes	0.017	0.041	0.007	
i-Nonanes	0.034	0.087	0.017	
n-Nonane	0.006	0.019	0.004	
i-Decanes	0.004	0.016	0.002	
n-Decane	0.002	0.004	0.001	
Undecanes	0.007	0.023	0.004	
Dodecanes	0.005	0.018	0.003	
Tridecanes	NIL	0.003	NIL	
Tetradecanes Plus	0.002	0.009	0.001	
	100.000	100.000	10.609	



Certificate of Analysis
Number: 6030-20040197-001A

Artesia Laboratory
200 E Main St.
Artesia, NM 88210
Phone 575-746-3481

Myke Lane
ConocoPhillips
935 N. Eldridge Parkway
Houston, TX 77079

Apr. 29, 2020

Station Name: EVG SAU CTB
Station Number: FWKO
Station Location: Conoco
Sample Point: FWKO GAS OUTLET
Analyzed: 04/28/2020 14:40:36 by User1

Sampled By: DEREK SAUDER
Sample Of: Gas Spot
Sample Date: 04/28/2020 10:15
Sample Conditions: 32.1 psig, @ 70 °F
Method: GPA 2286
Cylinder No: 5030-01060

Calculated Physical Properties	Total	C14+
Calculated Molecular Weight	46.060	212.419
GPA 2172 Calculation:		
Calculated Gross BTU per ft³ @ 14.73 psia & 60°F		
Real Gas Dry BTU	1090.6	11627.8
Water Sat. Gas Base BTU	1071.6	11301.7
Relative Density Real Gas	1.6067	7.3343
Compressibility Factor	0.9892	

Comments: H2S Field Content 9234 ppm

Hydrocarbon Laboratory Manager

Quality Assurance: The above analyses are performed in accordance with ASTM, UOP, GPA guidelines for quality assurance, unless otherwise stated.



Certificate of Analysis
 Number: 6030-20040197-001A

Artesia Laboratory
 200 E Main St.
 Artesia, NM 88210
 Phone 575-746-3481

Myke Lane
 ConocoPhillips
 935 N. Eldridge Parkway
 Houston, TX 77079

Apr. 29, 2020

Station Name: EVG SAU CTB
 Station Number: FWKO
 Station Location: Conoco
 Sample Point: FWKO GAS OUTLET
 Analyzed: 04/28/2020 14:40:36 by User1

Sampled By: DEREK SAUDER
 Sample Of: Gas Spot
 Sample Date: 04/28/2020 10:15
 Sample Conditions: 32.1 psig, @ 70 °F
 Method: GPA 2286
 Cylinder No: 5030-01060

Components	Mol %	Wt %
Unknown Iso-Hexane	0.025	0.048
Hydrogen Sulfide	0.923	0.683
Nitrogen	0.590	0.359
Methane	3.637	1.267
Carbon Dioxide	60.460	57.767
Ethane	1.588	1.037
Propane	15.083	14.440
Iso-Butane	4.027	5.082
n-Butane	9.173	11.575
Iso-Pentane	1.513	2.370
n-Pentane	1.312	2.055
2,2-Dimethylbutane	0.006	0.012
2,3-Dimethylbutane	0.054	0.102
Cyclopentane	0.067	0.102
2-Methylpentane	0.232	0.434
3-Methylpentane	0.151	0.284
n-Hexane	0.243	0.463
2,2-Dimethylpentane	0.002	0.003
Methylcyclopentane	0.157	0.290
Benzene	0.067	0.114
3,3-Dimethylpentane	0.002	0.003
Cyclohexane	0.138	0.254
2-Methylhexane	0.028	0.062
2,3-Dimethylpentane	0.016	0.034
3-Methylhexane	0.045	0.098
1,t-3-Dimethylcyclopentane	0.023	0.049
1,c-3-Dimethylcyclopentane	0.016	0.034
3-Ethylpentane	0.002	0.004
1,t-2-Dimethylcyclopentane	0.028	0.060
2,2,4-Trimethylpentane	0.003	0.007
n-Heptane	0.060	0.131
1,1,3-Trimethylcyclopentane	0.005	0.013
2,2-Dimethylhexane	0.002	0.006
Methylcyclohexane	0.078	0.167
2,5-Dimethylhexane	0.002	0.005
Unknown Iso-Octane	0.026	0.065
2,2,3-Trimethylpentane	NIL	0.001
2,4-Dimethylhexane	0.002	0.004
Ethylcyclopentane	0.005	0.011
1,t-2,c-4-Trimethylcyclopentane	0.006	0.014
3,3-Dimethylhexane	NIL	0.001
2,3,4-Trimethylpentane	0.006	0.017



Certificate of Analysis
 Number: 6030-20040197-001A

Artesia Laboratory
 200 E Main St.
 Artesia, NM 88210
 Phone 575-746-3481

Myke Lane
 ConocoPhillips
 935 N. Eldridge Parkway
 Houston, TX 77079

Apr. 29, 2020

Station Name: EVG SAU CTB
 Station Number: FWKO
 Station Location: Conoco
 Sample Point: FWKO GAS OUTLET
 Analyzed: 04/28/2020 14:40:36 by User1

Sampled By: DEREK SAUDER
 Sample Of: Gas Spot
 Sample Date: 04/28/2020 10:15
 Sample Conditions: 32.1 psig, @ 70 °F
 Method: GPA 2286
 Cylinder No: 5030-01060

Components	Mol %	Wt %
Toluene	0.064	0.127
2-Methylheptane	0.005	0.010
3-Methylheptane	0.008	0.019
1,c-3-Dimethylcyclohexane	0.009	0.022
1,t-2-Dimethylcyclohexane	0.002	0.002
n-Octane	0.016	0.037
1,c-4-Dimethylcyclohexane	0.003	0.006
1,t-3-Dimethylcyclohexane	0.003	0.006
Unknown Iso-Nonane	0.014	0.040
1,c-2-Dimethylcyclohexane	0.003	0.006
2,6-Dimethylheptane	NIL	0.002
Ethylcyclohexane	0.009	0.021
Ethylbenzene	0.016	0.036
3,4-Dimethylheptane	NIL	0.001
m-Xylene	0.006	0.015
p-Xylene	0.006	0.015
o-Xylene	0.005	0.011
n-Nonane	0.006	0.019
n-Butylcyclopentane	NIL	0.001
n-Propylcyclohexane	NIL	0.001
Unknown Iso-Decane	0.002	0.003
n-Propylbenzene	NIL	0.001
1,2,4-Trimethylbenzene	0.002	0.003
Methylcyclooctane	NIL	0.001
tert-Butylbenzene	NIL	0.001
n-Decane	0.002	0.004
Isobutylbenzene	NIL	0.002
sec-Butylbenzene	NIL	0.001
Unknown Iso-Undecane	0.005	0.017
1,2,3-Trimethylbenzene	0.002	0.005
n-Butylcyclohexane	NIL	0.001
n-Butylbenzene	NIL	0.001
n-Undecane	0.002	0.006
Unknown Iso-Dodecane	0.005	0.015
n-Dodecane	NIL	0.003
Unknown Iso-Tridecane	NIL	0.002
n-Tridecane	NIL	0.001
Tetradecanes Plus	0.002	0.009
	<u>100.000</u>	<u>100.000</u>

Annual tank loss calculations for "P Water".
 Total working and breathing losses are 61.29 ton/yr.
 * Only Non-Exempt VOCs are reported.
 Vapor adjusted to ensure mass balance

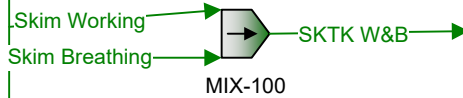

Skim Tank (T-11)

Annual tank loss calculations for "To H2O Tank".
 Total working and breathing losses are 40.64 ton/yr.
 * Only Non-Exempt VOCs are reported.
 Vapor adjusted to ensure mass balance



Produced Water Tank (T-15)

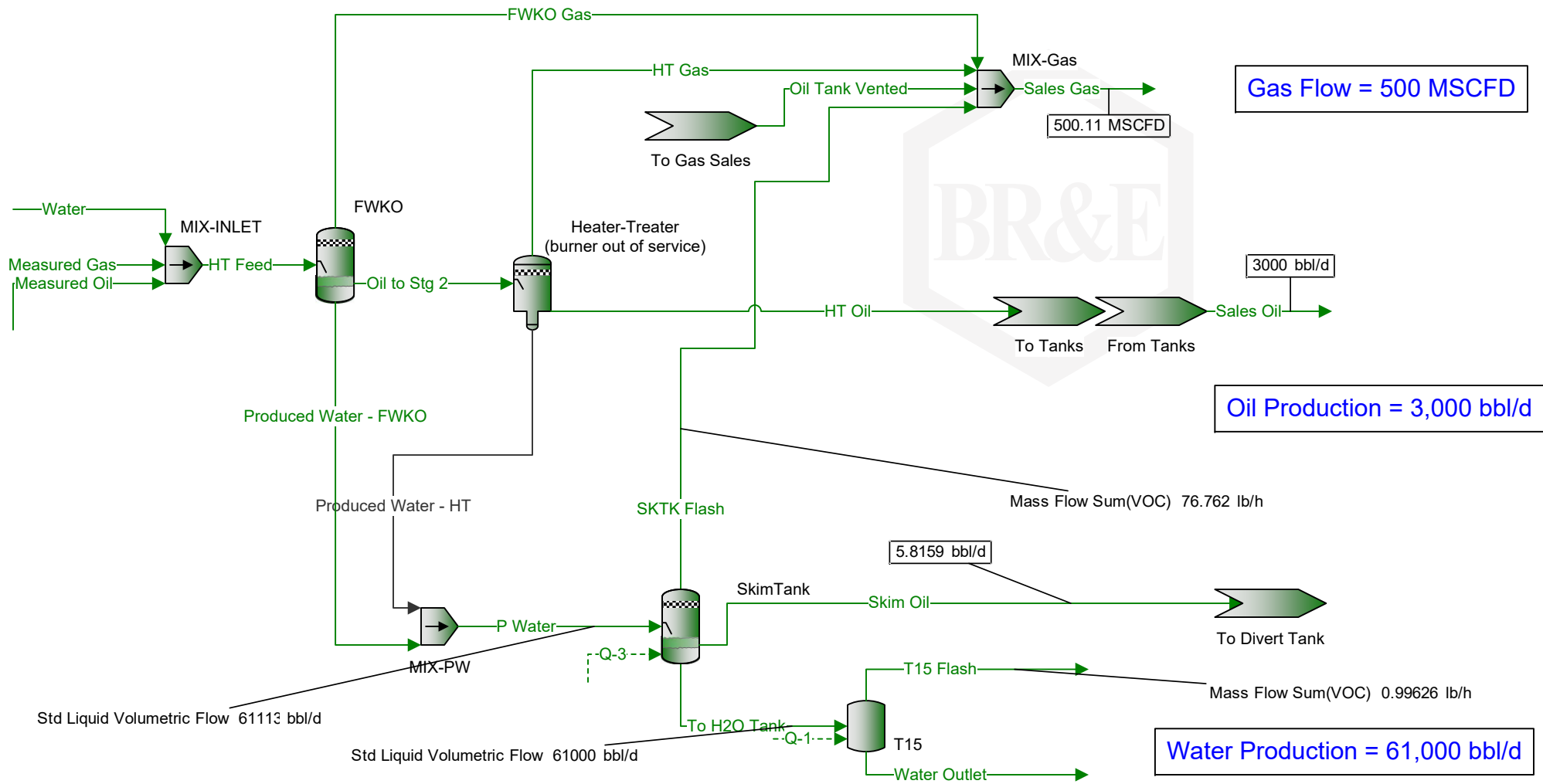

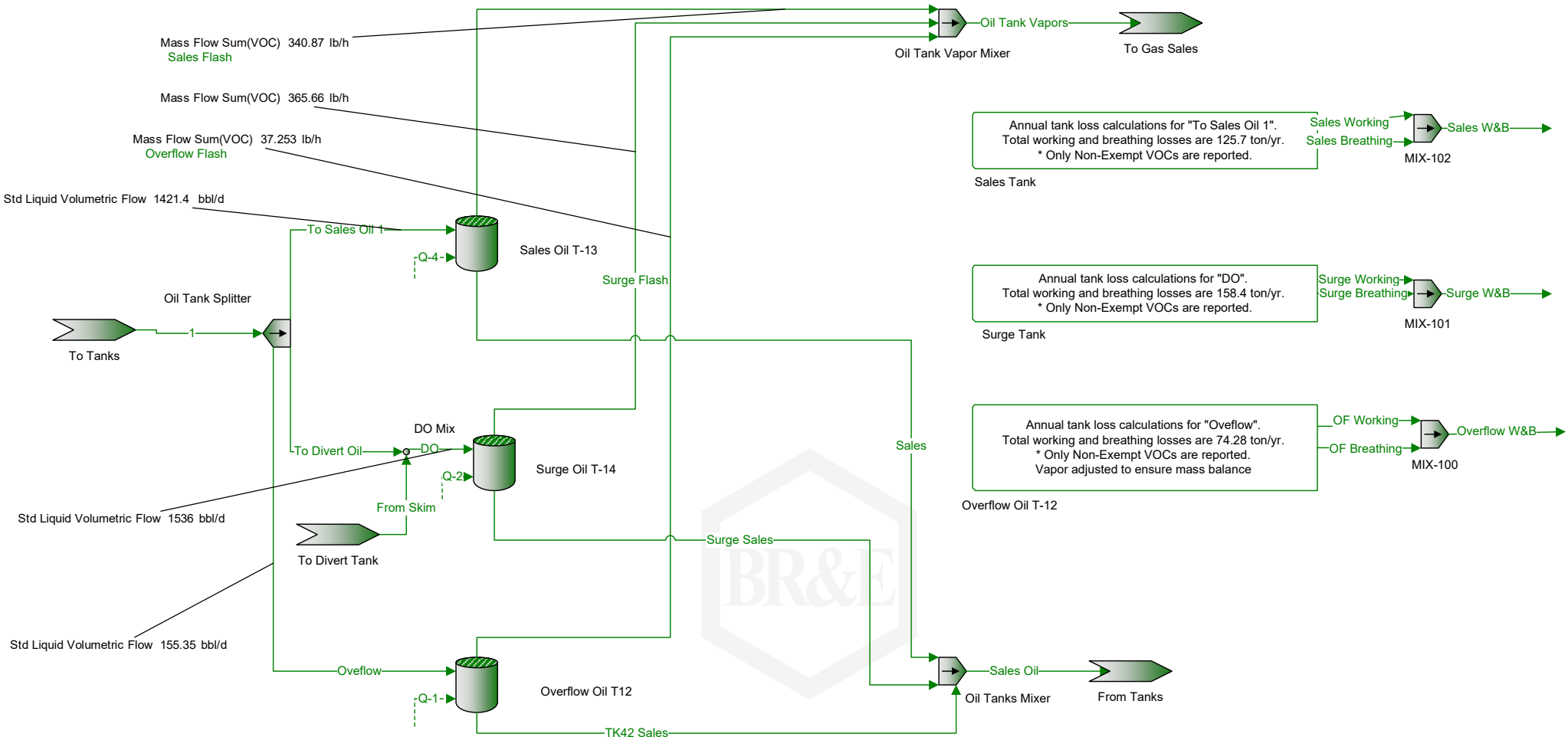

Process Streams Report
All Streams
 Tabulated by Total Phase

Client Name:	ConocoPhillips	Job: Tank Battery Emissions
Location:		
Flowsheet:	Oil Tanks	

Connections

	Overflow Flash	Overflow W&B	Sales Flash	Sales W&B	Surge Flash
From Block	Overflow Oil T12	MIX-100	Sales Oil T-13	MIX-102	Surge Oil T-14
To Block	Oil Tank Vapor Mixer	--	Oil Tank Vapor Mixer	--	Oil Tank Vapor Mixer

Stream Composition

Mole Fraction	Overflow Flash %	Overflow W&B %	Sales Flash %	Sales W&B %	Surge Flash %
H2S	0.335866	0.443516	0.335866	0.387651	0.336748
Nitrogen	0.12046	0.0045428	0.12046	0.0067138	0.120735
Methane	2.94933	0.395442	2.94933	0.790895	2.95557
CO2	20.1077	6.77316	20.1077	18.9047	20.1693
Ethane	3.92019	2.98545	3.92019	5.08334	3.92501
Propane	37.5082	50.1241	37.5082	42.0103	37.496
Isobutane	8.05757	9.74273	8.05757	8.14996	8.04487
n-Butane	16.5658	19.9528	16.5658	16.6796	16.5332
Isopentane	2.60386	2.93873	2.60386	2.45299	2.59705
n-Pentane	2.22731	2.4987	2.22731	2.08479	2.22116
i-Hexane	1.5634	1.60051	1.5634	1.33417	1.55905
n-Hexane	0.769264	0.811742	0.769264	0.676401	0.767071
2,2,4-Trimethylpentane	0.0102685	0.00833502	0.0102685	0.00693993	0.010244
Benzene	0.198164	0.173751	0.198164	0.144716	0.197967
Heptane	1.15807	1.00983	1.15807	0.840561	1.15522
Toluene	0.18683	0.163476	0.18683	0.136035	0.186602
Octane	0.358283	0.256983	0.358283	0.213657	0.3577
Ethylbenzene	0.0506526	0.0446684	0.0506526	0.0371361	0.0506027
o-Xylene	0.0197032	0.0157968	0.0197032	0.0131297	0.0196861
Nonane	0.0927335	0.0533284	0.0927335	0.0443311	0.0927104
C10+ (Oil)	0.000142233	6.63645E-05	0.000142233	5.4772E-05	0.000142488
Water	1.19623	0.00228704	1.19623	0.00190953	1.20344

Molar Flow	Overflow Flash lbmol/h	Overflow W&B lbmol/h	Sales Flash lbmol/h	Sales W&B lbmol/h	Surge Flash lbmol/h
H2S	0.00325421	0.00159696	0.029776	0.00282232	0.0320676
Nitrogen	0.00116713	1.63572E-05	0.0106793	4.88804E-05	0.0114973
Methane	0.0285761	0.00142386	0.261472	0.00575818	0.281452
CO2	0.194823	0.024388	1.78263	0.137637	1.92067
Ethane	0.0379827	0.0107497	0.347542	0.0370097	0.373769
Propane	0.363417	0.180481	3.32527	0.30586	3.57064
Isobutane	0.0780699	0.0350805	0.714339	0.0593364	0.766092
n-Butane	0.160506	0.0718438	1.46863	0.121437	1.57441
Isopentane	0.0252288	0.0105814	0.230843	0.0178592	0.247311
n-Pentane	0.0215804	0.00899705	0.197461	0.0151785	0.211515
i-Hexane	0.0151478	0.00576295	0.138603	0.00971352	0.148464
n-Hexane	0.0074534	0.00292283	0.0681986	0.00492459	0.0730461
2,2,4-Trimethylpentane	9.94915E-05	3.00118E-05	0.000910347	5.05267E-05	0.000975505
Benzene	0.00192002	0.000625621	0.0175682	0.00105362	0.0188519
Heptane	0.0112206	0.00363607	0.102668	0.00611977	0.110009
Toluene	0.0018102	0.000588627	0.0165633	0.000990412	0.0177697
Octane	0.0034714	0.000925314	0.0317633	0.00155555	0.0340629
Ethylbenzene	0.000490773	0.000160837	0.00449057	0.000270373	0.00481877
o-Xylene	0.000190904	5.68792E-05	0.00174677	9.5592E-05	0.00187466
Nonane	0.000898496	0.000192019	0.00822123	0.000322756	0.00882857
C10+ (Oil)	1.3781E-06	2.38958E-07	1.26096E-05	3.98772E-07	1.35688E-05
Water	0.0115903	8.23489E-06	0.106051	1.39025E-05	0.114601

Process Streams Report All Streams Tabulated by Total Phase

Client Name:	ConocoPhillips	Job: Tank Battery Emissions
Location:		
Flowsheet:	Oil Tanks	

Mass Fraction	Overflow Flash %	Overflow W&B %	Sales Flash %	Sales W&B %	Surge Flash %
H2S	0.232116	0.295264	0.232116	0.266816	0.232818
Nitrogen	0.0684283	0.00248588	0.0684283	0.00379835	0.0686117
Methane	0.959453	0.123921	0.959453	0.256242	0.961863
CO2	17.9447	5.82275	17.9447	16.8026	18.0068
Ethane	2.39031	1.75356	2.39031	3.08695	2.3942
Propane	33.539	43.175	33.539	37.4121	33.5414
Isobutane	9.49675	11.0615	9.49675	9.5666	9.48552
n-Butane	19.5246	22.6536	19.5246	19.5788	19.4939
Isopentane	3.80956	4.14171	3.80956	3.57425	3.80111
n-Pentane	3.25865	3.52155	3.25865	3.03774	3.25094
i-Hexane	2.73201	2.69422	2.73201	2.32196	2.72548
n-Hexane	1.34427	1.36644	1.34427	1.17719	1.34097
2,2,4-Trimethylpentane	0.0237854	0.0185982	0.0237854	0.0160099	0.0237379
Benzene	0.313886	0.265115	0.313886	0.228294	0.313697
Heptane	2.3531	1.97658	2.3531	1.70101	2.34824
Toluene	0.349073	0.29423	0.349073	0.253134	0.348786
Octane	0.829906	0.573415	0.829906	0.492893	0.828885
Ethylbenzene	0.109046	0.0926344	0.109046	0.0796229	0.108982
o-Xylene	0.0424176	0.0327597	0.0424176	0.0281512	0.0423977
Nonane	0.241179	0.133605	0.241179	0.114827	0.241215
C10+ (Oil)	0.000673372	0.000302658	0.000673372	0.000258253	0.000674846
Water	0.437004	0.00080483	0.437004	0.00069475	0.439812

Mass Flow	Overflow Flash lb/h	Overflow W&B lb/h	Sales Flash lb/h	Sales W&B lb/h	Surge Flash lb/h
H2S	0.110906	0.0544259	1.01479	0.0961872	1.09289
Nitrogen	0.0326954	0.00045822	0.299163	0.00136931	0.322077
Methane	0.458431	0.0228423	4.19465	0.0923753	4.51518
CO2	8.57407	1.0733	78.4528	6.05736	84.5276
Ethane	1.1421	0.323232	10.4502	1.11284	11.2389
Propane	16.0251	7.95843	146.63	13.4871	157.45
Isobutane	4.53759	2.03896	41.519	3.44876	44.5269
n-Butane	9.32896	4.17572	85.36	7.05818	91.5082
Isopentane	1.82023	0.763438	16.6551	1.28852	17.8432
n-Pentane	1.557	0.649126	14.2466	1.09511	15.2605
i-Hexane	1.30537	0.496624	11.9441	0.837066	12.794
n-Hexane	0.6423	0.251876	5.87704	0.424378	6.29478
2,2,4-Trimethylpentane	0.0113648	0.0034282	0.103988	0.00577159	0.111443
Benzene	0.149976	0.0488684	1.37228	0.0822999	1.47256
Heptane	1.12432	0.364341	10.2875	0.613213	11.0231
Toluene	0.166789	0.0542352	1.52612	0.091255	1.63727
Octane	0.396533	0.105697	3.62828	0.177688	3.89095
Ethylbenzene	0.0521029	0.0170752	0.476742	0.0287041	0.511584
o-Xylene	0.0202674	0.00603858	0.185446	0.0101485	0.199023
Nonane	0.115237	0.0246274	1.05442	0.0413951	1.13231
C10+ (Oil)	0.000321741	5.57887E-05	0.00294393	9.31001E-05	0.00316786
Water	0.208803	0.000148354	1.91054	0.000250457	2.06456

Stream Properties						
Property	Units	Overflow Flash	Overflow W&B	Sales Flash	Sales W&B	Surge Flash
Temperature	°F	90 *	86.651	90 *	86.4121	90 *
Pressure	psia	13.28 *	17.3649	13.28 *	20.9329	13.28 *
Mole Fraction Vapor	%	100	100	100	100	100
Mole Fraction Light Liquid	%	0	0	0	0	0
Mole Fraction Heavy Liquid	%	0	0	0	0	0
Molecular Weight	lb/lbmol	49.3141	51.1929	49.3141	49.5153	49.2946
Mass Density	lb/ft^3	0.112603	0.155201	0.112603	0.181078	0.112556

* User Specified Values
? Extrapolated or Approximate Values

Process Streams Report
All Streams
 Tabulated by Total Phase

Client Name:	ConocoPhillips	Job: Tank Battery Emissions
Location:		
Flowsheet:	Oil Tanks	

Stream Properties

Property	Units	Overflow Flash	Overflow W&B	Sales Flash	Sales W&B	Surge Flash
Molar Flow	lbmol/h	0.968901	0.360068	8.86544	0.728058	9.52274
Mass Flow	lb/h	47.7805	18.4329	437.191	36.05	469.42
Vapor Volumetric Flow	ft ³ /h	424.326	118.768	3882.58	199.086	4170.53
Liquid Volumetric Flow	gpm	52.903	14.8074	484.062	24.8211	519.962
Std Vapor Volumetric Flow	MMSCFD	0.00882438	0.00327937	0.080743	0.00663087	0.0867295
Std Liquid Volumetric Flow	sgpm	0.1647	0.0661173	1.50701	0.125796	1.61792
Compressibility		0.985946	0.976955	0.985946	0.976749	0.985966
Specific Gravity		1.70269	1.76756	1.70269	1.70964	1.70202
API Gravity						
Enthalpy	Btu/h	-71761.5	-20843.6	-656617	-52361.9	-705959
Mass Enthalpy	Btu/lb	-1501.9	-1130.78	-1501.9	-1452.48	-1503.9
Mass Cp	Btu/(lb*°F)	0.373226	0.396315	0.373226	0.374789	0.373101
Ideal Gas CpCv Ratio		1.12183	1.10966	1.12183	1.1213	1.12193
Dynamic Viscosity	cP	0.00924122	0.00836906	0.00924122	0.00909528	0.00924607
Kinematic Viscosity	cSt	5.12339	3.36636	5.12339	3.13567	5.12821
Thermal Conductivity	Btu/(h*ft*°F)	0.0101634	0.00995215	0.0101634	0.00999193	0.0101644
Surface Tension	lbf/ft					
Net Ideal Gas Heating Value	Btu/ft ³	2087.62	2501.96	2087.62	2139.51	2085.14
Net Liquid Heating Value	Btu/lb	15917.6	18391.4	15917.6	16251.7	15904.9
Gross Ideal Gas Heating Value	Btu/ft ³	2265.07	2713.75	2265.07	2321.09	2262.39
Gross Liquid Heating Value	Btu/lb	17283.2	19961.4	17283.2	17643.4	17269.5

Remarks

Process Streams Report All Streams Tabulated by Total Phase					
Client Name:	ConocoPhillips			Job: Tank Battery Emissions	
Location:					
Flowsheet:	Oil Tanks				
Connections					
	From Block	Surge W&B			
	To Block	MIX-101			
		--			
Stream Composition					
	Mole Fraction	Surge W&B %			
	H2S	0.387891			
	Nitrogen	0.00667225			
	Methane	0.785258			
	CO2	18.8841			
	Ethane	5.06664			
	Propane	41.9664			
	Isobutane	8.15885			
	n-Butane	16.7116			
	Isopentane	2.4626			
	n-Pentane	2.09426			
	i-Hexane	1.34219			
	n-Hexane	0.680921			
	2,2,4-Trimethylpentane	0.00699692			
	Benzene	0.146122			
	Heptane	0.847957			
	Toluene	0.137547			
	Octane	0.216134			
	Ethylbenzene	0.0376177			
	o-Xylene	0.013308			
	Nonane	0.0449159			
	C10+ (Oil)	5.63615E-05			
	Water	0.00193534			
	Molar Flow	Surge W&B lbmol/h			
	H2S	0.00355623			
	Nitrogen	6.11719E-05			
	Methane	0.00719933			
	CO2	0.173131			
	Ethane	0.0464515			
	Propane	0.384753			
	Isobutane	0.0748012			
	n-Butane	0.153214			
	Isopentane	0.0225774			
	n-Pentane	0.0192004			
	i-Hexane	0.0123054			
	n-Hexane	0.00624275			
	2,2,4-Trimethylpentane	6.41485E-05			
	Benzene	0.00133967			
	Heptane	0.00777416			
	Toluene	0.00126105			
	Octane	0.00198154			
	Ethylbenzene	0.000344883			
	o-Xylene	0.000122009			
	Nonane	0.000411794			
	C10+ (Oil)	5.16728E-07			
	Water	1.77434E-05			
	Mass Fraction	Surge W&B %			
	H2S	0.266829			
	Nitrogen	0.00377268			
	Methane	0.25427			

Process Streams Report
All Streams
 Tabulated by Total Phase

Client Name:	ConocoPhillips	Job: Tank Battery Emissions
Location:		
Flowsheet:	Oil Tanks	

Mass Fraction	Surge W&B %			
CO2	16.7747			
Ethane	3.07504			
Propane	37.3516			
Isobutane	9.57157			
n-Butane	19.6052			
Isopentane	3.58621			
n-Pentane	3.0498			
i-Hexane	2.33459			
n-Hexane	1.18438			
2,2,4-Trimethylpentane	0.0161322			
Benzene	0.23038			
Heptane	1.71499			
Toluene	0.255802			
Octane	0.498322			
Ethylbenzene	0.0806093			
o-Xylene	0.028517			
Nonane	0.116275			
C10+ (Oil)	0.000265595			
Water	0.000703736			

Mass Flow	Surge W&B lb/h			
H2S	0.121199			
Nitrogen	0.00171363			
Methane	0.115495			
CO2	7.61942			
Ethane	1.39675			
Propane	16.9659			
Isobutane	4.34761			
n-Butane	8.90512			
Isopentane	1.62893			
n-Pentane	1.38529			
i-Hexane	1.06042			
n-Hexane	0.537971			
2,2,4-Trimethylpentane	0.00732759			
Benzene	0.104644			
Heptane	0.778986			
Toluene	0.116191			
Octane	0.226349			
Ethylbenzene	0.0366145			
o-Xylene	0.0129531			
Nonane	0.0528147			
C10+ (Oil)	0.000120639			
Water	0.000319652			

Stream Properties

Property	Units	Surge W&B		
Temperature	°F	86.8281		
Pressure	psia	20.9346		
Mole Fraction Vapor	%	100		
Mole Fraction Light Liquid	%	0		
Mole Fraction Heavy Liquid	%	0		
Molecular Weight	lb/lbmol	49.5437		
Mass Density	lb/ft^3	0.181055		
Molar Flow	lbmol/h	0.916811		
Mass Flow	lb/h	45.4222		
Vapor Volumetric Flow	ft^3/h	250.875		
Liquid Volumetric Flow	gpm	31.2779		
Std Vapor Volumetric Flow	MMSCFD	0.00834996		
Std Liquid Volumetric Flow	sgpm	0.158468		

* User Specified Values
 ? Extrapolated or Approximate Values

ProMax 5.0.20169.0
 Copyright © 2002-2020 BRE Group, Ltd.

Licensed to Portnoy Environmental, Inc. and Affiliates

Process Streams Report All Streams Tabulated by Total Phase						
Client Name:	ConocoPhillips				Job: Tank Battery Emissions	
Location:						
Flowsheet:	Oil Tanks					
Stream Properties						
Property	Units	Surge W&B				
Compressibility		0.976765				
Specific Gravity		1.71061				
API Gravity						
Enthalpy	Btu/h	-65920.3				
Mass Enthalpy	Btu/lb	-1451.28				
Mass Cp	Btu/(lb*°F)	0.375042				
Ideal Gas CpCv Ratio		1.12112				
Dynamic Viscosity	cP	0.00909896				
Kinematic Viscosity	cSt	3.13733				
Thermal Conductivity	Btu/(h*ft*°F)	0.0100034				
Surface Tension	lbf/ft					
Net Ideal Gas Heating Value	Btu/ft^3	2141.37				
Net Liquid Heating Value	Btu/lb	16256.5				
Gross Ideal Gas Heating Value	Btu/ft^3	2323.1				
Gross Liquid Heating Value	Btu/lb	17648.6				
Remarks						

Separations Plant Schematic

Client Name:	ConocoPhillips	Job: Tank Battery Emissions
Location:		
Flowsheet:	Separations	

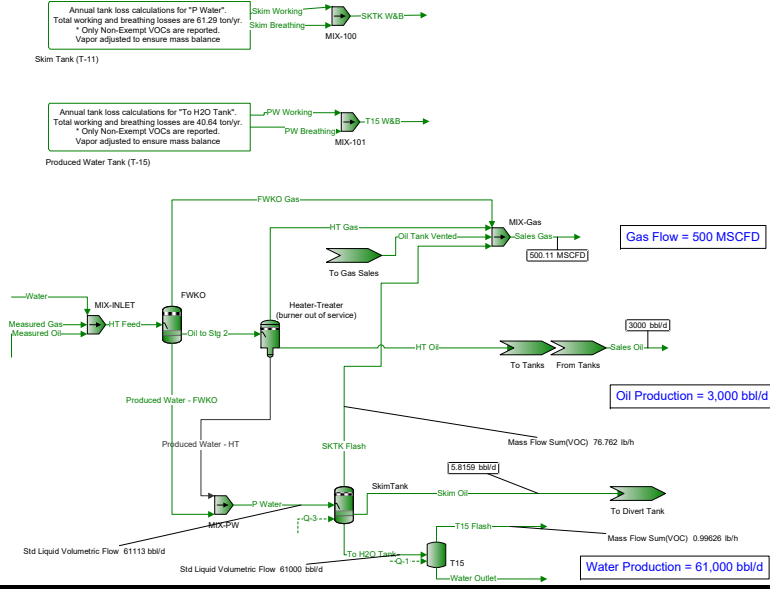

* User Specified Values
 ? Extrapolated or Approximate Values

Process Streams Report
All Streams
 Tabulated by Total Phase

Client Name:	ConocoPhillips	Job: Tank Battery Emissions
Location:		
Flowsheet:	Separations	

Connections

	Measured Gas	Measured Oil	Sales Gas	Sales Oil	SKTK Flash
From Block	--	--	MIX-Gas	From Tanks	SkimTank
To Block	MIX-INLET	MIX-INLET	--	--	MIX-Gas

Stream Composition

Mole Fraction	Measured Gas %	Measured Oil %	Sales Gas %	Sales Oil %	SKTK Flash %
H2S	0.923018 *	0 *	0.494129	0.0131759	0.660669
Nitrogen	0.590012 *	0.006 *	0.84149	0.000134961	0.444363
Methane	3.63707 *	0.031 *	5.08107	0.011669	3.22015
CO2	60.4612 *	1.347 *	57.6525	0.199129	85.3582
Ethane	1.58803 *	0.13 *	2.3496	0.0880888	0.887483
Propane	15.0833 *	1.944 *	16.4489	2.98064	2.46958
Isobutane	4.02708 *	1.107 *	3.25997	1.64349	0.277476
n-Butane	9.17318 *	3.61 *	6.70396	4.97832	0.687891
Isopentane	1.51303 *	1.711 *	1.03588	1.92714	0.096897
n-Pentane	1.31203 *	2.028 *	0.87651	2.20786	0.0686581
i-Hexane	0.673013 *	3.447 *	0.634922	3.43749	0.0900308
n-Hexane	0.243005 *	2.495 *	0.317973	2.44057	0.0557698
2,2,4-Trimethylpentane	0 *	0.08 *	0.00469061	0.0769719	0.00159965
Benzene	0.0670013 *	0.938 *	0.146827	0.831622	0.137425
Heptane	0.382008 *	10.33 *	0.540635	10.0823	0.203071
Toluene	0.0640013 *	2.748 *	0.133657	2.62435	0.120856
Octane	0.172003 *	9.299 *	0.214345	9.08397	0.152507
Ethylbenzene	0.0160003 *	2.222 *	0.0379874	2.1533	0.0361416
o-Xylene	0.0170003 *	1.123 *	0.0151516	1.09092	0.0147729
Nonane	0.0400008 *	7.245 *	0.0775152	7.06753	0.0813774
C10+ (Oil)	0.0180004 *	48.159 *	0.000162326	47.02	0.000207979
Water	0 *	0 *	3.13207	0.0413911	4.93484

Molar Flow	Measured Gas lbmol/h	Measured Oil lbmol/h	Sales Gas lbmol/h	Sales Oil lbmol/h	SKTK Flash lbmol/h
H2S	0.705992 *	0 *	0.271333	0.030159	0.19121
Nitrogen	0.451285 *	0.0134073 *	0.462074	0.000308919	0.128607
Methane	2.7819 *	0.0692709 *	2.79008	0.0267099	0.931969
CO2	46.2452 *	3.00993 *	31.6578	0.455797	24.7042
Ethane	1.21464 *	0.290491 *	1.2902	0.201631	0.256854
Propane	11.5368 *	4.34395 *	9.03232	6.82254	0.714741
Isobutane	3.08021 *	2.47364 *	1.79009	3.76188	0.0803065
n-Butane	7.01632 *	8.0667 *	3.68123	11.3951	0.199088
Isopentane	1.15728 *	3.8233 *	0.568815	4.41114	0.0280437
n-Pentane	1.00354 *	4.53165 *	0.481304	5.05369	0.0198709
i-Hexane	0.51477 *	7.70247 *	0.348644	7.86826	0.0260565
n-Hexane	0.185868 *	5.57519 *	0.174604	5.58634	0.0161408
2,2,4-Trimethylpentane	0 *	0.178764 *	0.00257568	0.176185	0.000462969
Benzene	0.0512475 *	2.096 *	0.0806249	1.90354	0.0397732
Heptane	0.292188 *	23.0828 *	0.29687	23.0779	0.0587725
Toluene	0.0489529 *	6.14053 *	0.0733931	6.00702	0.0349778
Octane	0.131561 *	20.779 *	0.1177	20.7928	0.0441383
Ethylbenzene	0.0122382 *	4.96516 *	0.0208594	4.9288	0.01046
o-Xylene	0.0130031 *	2.50939 *	0.00831996	2.49706	0.00427554
Nonane	0.0305956 *	16.1893 *	0.0425646	16.1773	0.0235521
C10+ (Oil)	0.013768 *	107.613 *	8.91352E-05	107.627	6.01928E-05
Water	0 *	0 *	1.71986	0.0947424	1.42823

Mass Fraction	Measured Gas %	Measured Oil %	Sales Gas %	Sales Oil %	SKTK Flash %
H2S	0.682083 *	0 *	0.380194	0.00281959	0.533052
Nitrogen	0.358379 *	0.00103969 *	0.532194	2.37393E-05	0.294699
Methane	1.26514 *	0.00307625 *	1.84027	0.00117544	1.22299
CO2	57.6952 *	0.366693 *	57.2822	0.055027	88.9337

* User Specified Values

? Extrapolated or Approximate Values

ProMax 5.0.20169.0
Copyright © 2002-2020 BRE Group, Ltd.

Licensed to Portnoy Environmental, Inc. and Affiliates

Process Streams Report
All Streams
 Tabulated by Total Phase

Client Name:	ConocoPhillips	Job: Tank Battery Emissions
Location:		
Flowsheet:	Separations	

Mass Fraction	Measured Gas %	Measured Oil %	Sales Gas %	Sales Oil %	SKTK Flash %
Ethane	1.03537 *	0.0241797 *	1.59503	0.0166316	0.631763
Propane	14.4214 *	0.530249 *	16.3752	0.825276	2.57806
Isobutane	5.07515 *	0.397995 *	4.2777	0.599798	0.381805
n-Butane	11.5605 *	1.29789 *	8.79687	1.81685	0.946534
Isopentane	2.36697 *	0.763603 *	1.6873	0.873047	0.165506
n-Pentane	2.05253 *	0.905077 *	1.42771	1.00022	0.117272
i-Hexane	1.25754 *	1.83744 *	1.23526	1.86003	0.183675
n-Hexane	0.454061 *	1.32997 *	0.618627	1.32059	0.113778
2,2,4-Trimethylpentane	0 *	0.0565266 *	0.0120965	0.0552079	0.00432589
Benzene	0.113479 *	0.453219 *	0.258928	0.407885	0.25413
Heptane	0.829975 *	6.40273 *	1.22302	6.34351	0.481725
Toluene	0.127863 *	1.5662 *	0.278028	1.5183	0.263623
Octane	0.426017 *	6.57051 *	0.552768	6.51546	0.41242
Ethylbenzene	0.036832 *	1.4592 *	0.0910492	1.43542	0.0908372
o-Xylene	0.039134 *	0.737479 *	0.0363158	0.727223	0.0371297
Nonane	0.11124 *	5.7478 *	0.224448	5.69164	0.247089
C10+ (Oil)	0.0911222 *	69.5491 *	0.000855594	68.9292	0.00114953
Water	0 *	0 *	1.27388	0.00468213	2.10469

Mass Flow	Measured Gas lb/h	Measured Oil lb/h	Sales Gas lb/h	Sales Oil lb/h	SKTK Flash lb/h
H2S	24.0608 *	0 *	9.24726	1.02784	6.51659
Nitrogen	12.642 *	0.375583 *	12.9443	0.00865387	3.60271
Methane	44.6285 *	1.11127 *	44.7598	0.428492	14.9511
CO2	2035.23 *	132.466 *	1393.24	20.0594	1087.22
Ethane	36.5231 *	8.73478 *	38.7951	6.06286	7.72334
Propane	508.723 *	191.549 *	398.286	300.844	31.5169
Isobutane	179.028 *	143.773 *	104.044	218.649	4.66759
n-Butane	407.804 *	468.855 *	213.961	662.31	11.5714
Isopentane	83.4961 *	275.847 *	41.0393	318.258	2.02332
n-Pentane	72.404 *	326.953 *	34.7255	364.617	1.43366
i-Hexane	44.3605 *	663.763 *	30.0446	678.05	2.24543
n-Hexane	16.0173 *	480.444 *	15.0465	481.405	1.39094
2,2,4-Trimethylpentane	0 *	20.4199 *	0.294216	20.1254	0.0528842
Benzene	4.00304 *	163.723 *	6.29776	148.689	3.10676
Heptane	29.2778 *	2312.95 *	29.7469	2312.45	5.88912
Toluene	4.51044 *	565.778 *	6.76233	553.477	3.2228
Octane	15.028 *	2373.56 *	13.4447	2375.13	5.04186
Ethylbenzene	1.29927 *	527.126 *	2.21454	523.266	1.11049
o-Xylene	1.38047 *	266.41 *	0.883288	265.1	0.453913
Nonane	3.92404 *	2076.36 *	5.45913	2074.82	3.02067
C10+ (Oil)	3.21438 *	25124.2 *	0.0208101	25127.3	0.014053
Water	0 *	0 *	30.9838	1.70681	25.73

Stream Properties

Property	Units	Measured Gas	Measured Oil	Sales Gas	Sales Oil	SKTK Flash
Temperature	°F	78 *	78 *	87.9379	90	90 *
Pressure	psia	68.28 *	68.28 *	13.28	13.28	14.28 *
Mole Fraction Vapor	%	99.1647	0	100	0	100
Mole Fraction Light Liquid	%	0.83526	100	0	100	0
Mole Fraction Heavy Liquid	%	0	0	0	0	0
Molecular Weight	lb/lbmol	46.1194	161.663	44.294	159.259	42.2401
Mass Density	lb/ft^3	0.574852	52.4019	0.10085	51.6845	0.102816
Molar Flow	lbmol/h	76.4874	223.454	54.9114	228.895	28.9418
Mass Flow	lb/h	3527.55	36124.4	2432.24	36453.8	1222.51
Vapor Volumetric Flow	ft^3/h	6136.46	689.371	24117.5	705.313	11890.2
Liquid Volumetric Flow	gpm	765.065	85.9476	3006.85	87.9351	1482.42
Std Vapor Volumetric Flow	MMSCFD	0.696618 *	2.03514	0.500112	2.08469	0.263591
Std Liquid Volumetric Flow	sgpm	10.4597	86.1978 *	7.26826	87.499	3.13971
Compressibility		0.949385	0.0365072	0.992509	0.00693709	0.994552

* User Specified Values

? Extrapolated or Approximate Values

ProMax 5.0.20169.0
Copyright © 2002-2020 BRE Group, Ltd.

Licensed to Portnoy Environmental, Inc. and Affiliates

Process Streams Report
All Streams
 Tabulated by Total Phase

Client Name:	ConocoPhillips	Job: Tank Battery Emissions
Location:		
Flowsheet:	Separations	

Stream Properties

Property	Units	Measured Gas	Measured Oil	Sales Gas	Sales Oil	SKTK Flash
Specific Gravity			0.840195	1.52936	0.828693	1.45844
API Gravity			35.3345		36.5503	
Enthalpy	Btu/h	-9.2869E+06	-2.8167E+07	-6.51703E+06	-2.80775E+07	-4.42827E+06
Mass Enthalpy	Btu/lb	-2632.67	-779.723	-2679.43	-770.222	-3622.29
Mass Cp	Btu/(lb*°F)	0.296476	0.433964	0.292043	0.4428	0.227355
Ideal Gas CpCv Ratio		1.1777	1.03775	1.18251	1.03737	1.2625
Dynamic Viscosity	cP		1.46223	0.0121125	1.23199	0.0147222
Kinematic Viscosity	cSt		1.742	7.49784	1.48808	8.93907
Thermal Conductivity	Btu/(h*ft*°F)		0.0713455	0.0102827	0.0703464	0.0101879
Surface Tension	lbf/ft		0.00200963	?	0.00189857	
Net Ideal Gas Heating Value	Btu/ft^3	996.111	7800.22	939.251	7715.08	183.502
Net Liquid Heating Value	Btu/lb	8087.76	18153.8	7927.81	18227	1547.45
Gross Ideal Gas Heating Value	Btu/ft^3	1080.86	8312.69	1021.18	8224.02	201.806
Gross Liquid Heating Value	Btu/lb	8785.18	19356.8	8629.76	19439.7	1711.92

Remarks

Process Streams Report
All Streams
 Tabulated by Total Phase

Client Name:	ConocoPhillips	Job: Tank Battery Emissions
Location:		
Flowsheet:	Separations	

Connections

	SKTK W&B	T15 Flash	T15 W&B		
From Block	MIX-100	T15	MIX-101		
To Block	--	--	--		

Stream Composition

Mole Fraction	SKTK W&B %	T15 Flash %	T15 W&B %		
H2S	1.12514	0.701609	1.22301		
Nitrogen	0.0118073	0.197159	0.00352749		
Methane	0.176244	2.04508	0.0837532		
CO2	91.1332	88.5	89.7599		
Ethane	0.0693492	0.638667	0.0384188		
Propane	0.138292	1.55635	0.0618946		
Isobutane	0.0109704	0.142176	0.00334309		
n-Butane	0.0386381	0.41885	0.0151867		
Isopentane	0.00472103	0.0485299	0.00109173		
n-Pentane	0.00239515	0.0208562	0.000194947		
i-Hexane	0.00562809	0.0325864	0.000399354		
n-Hexane	0.00408636	0.0123762	7.28691E-05		
2,2,4-Trimethylpentane	0.000236993	0.000325308	1.60295E-06		
Benzene	0.21054	0.146571	0.242898		
Heptane	0.0355948	0.0336255	0.000133257		
Toluene	0.185162	0.128593	0.21341		
Octane	0.0736489	0.0124005	2.15129E-05		
Ethylbenzene	0.0524042	0.0383838	0.0622693		
o-Xylene	0.0216063	0.0157387	0.0257056		
Nonane	0.106696	0.00567976	7.9459E-06		
C10+ (Oil)	0.000201001	0.000221606	0.000327694		
Water	6.59344	5.30427	8.26446		

Molar Flow	SKTK W&B lbmol/h	T15 Flash lbmol/h	T15 W&B lbmol/h		
H2S	0.20333	0.00482848	0.218212		
Nitrogen	0.00213375	0.00135685	0.000629382		
Methane	0.0318498	0.0140743	0.0149434		
CO2	16.4691	0.609058	16.0151		
Ethane	0.0125324	0.00439531	0.00685475		
Propane	0.0249914	0.0107108	0.0110434		
Isobutane	0.0019825	0.00097846	0.000596481		
n-Butane	0.00698246	0.00288253	0.00270965		
Isopentane	0.000853159	0.000333983	0.00019479		
n-Pentane	0.000432839	0.000143533	3.47829E-05		
i-Hexane	0.00101708	0.00022426	7.12535E-05		
n-Hexane	0.000738464	8.5173E-05	1.30015E-05		
2,2,4-Trimethylpentane	4.28282E-05	2.23877E-06	2.86002E-07		
Benzene	0.0380476	0.0010087	0.0433384		
Heptane	0.0064325	0.000231411	2.3776E-05		
Toluene	0.0334615	0.000884978	0.0380771		
Octane	0.0133094	8.53402E-05	3.83838E-06		
Ethylbenzene	0.0094702	0.000264158	0.0111102		
o-Xylene	0.00390458	0.000108314	0.00458645		
Nonane	0.0192815	3.90882E-05	1.41772E-06		
C10+ (Oil)	3.63237E-05	1.5251E-06	5.84678E-05		
Water	1.19153	0.036504	1.47456		

Mass Fraction	SKTK W&B %	T15 Flash %	T15 W&B %		
H2S	0.902142	0.567078	0.993483		
Nitrogen	0.00778168	0.130984	0.00235533		
Methane	0.0665184	0.778068	0.0320252		

Process Streams Report
All Streams
 Tabulated by Total Phase

Client Name:	ConocoPhillips	Job: Tank Battery Emissions
Location:		
Flowsheet:	Separations	

Mass Fraction	SKTK W&B %	T15 Flash %	T15 W&B %		
CO2	94.3582	92.369	94.1562		
Ethane	0.0490589	0.45544	0.0275349		
Propane	0.143466	1.62757	0.0650532		
Isobutane	0.015001	0.195978	0.00463138		
n-Butane	0.0528341	0.577348	0.0210391		
Isopentane	0.00801351	0.0830377	0.00187744		
n-Pentane	0.00406555	0.0356863	0.000335248		
i-Hexane	0.0114104	0.0665973	0.000820278		
n-Hexane	0.00828469	0.0252934	0.000149674		
2,2,4-Trimethylpentane	0.000636895	0.000881264	4.3643E-06		
Benzene	0.386908	0.27152	0.452232		
Heptane	0.0839112	0.0799065	0.000318264		
Toluene	0.401375	0.280992	0.468679		
Octane	0.197924	0.033593	5.85725E-05		
Ethylbenzene	0.130889	0.0966421	0.157571		
o-Xylene	0.0539658	0.0396267	0.0650474		
Nonane	0.321944	0.0172759	2.42906E-05		
C10+ (Oil)	0.00110403	0.001227	0.00182354		
Water	2.79453	2.26623	3.54875		

Mass Flow	SKTK W&B lb/h	T15 Flash lb/h	T15 W&B lb/h		
H2S	6.92965	0.164559	7.43685		
Nitrogen	0.0597736	0.03801	0.0176311		
Methane	0.510949	0.225786	0.239729		
CO2	724.796	26.8043	704.818		
Ethane	0.376838	0.132163	0.206116		
Propane	1.10201	0.4723	0.486964		
Isobutane	0.115227	0.0568703	0.0346688		
n-Butane	0.405836	0.167539	0.157491		
Isopentane	0.0615544	0.0240965	0.0140538		
n-Pentane	0.0312288	0.0103557	0.00250954		
i-Hexane	0.0876471	0.0193257	0.00614029		
n-Hexane	0.0636374	0.00733981	0.0011204		
2,2,4-Trimethylpentane	0.0048922	0.000255732	3.26696E-05		
Benzene	2.97196	0.0787918	3.38524		
Heptane	0.644549	0.0231879	0.0023824		
Toluene	3.08309	0.0815405	3.50836		
Octane	1.52032	0.00974828	0.000438452		
Ethylbenzene	1.0054	0.0280443	1.17952		
o-Xylene	0.414529	0.0114992	0.486921		
Nonane	2.47295	0.00501326	0.00018183		
C10+ (Oil)	0.0084804	0.00035606	0.0136503		
Water	21.4657	0.65763	26.5647		

Stream Properties

Property	Units	SKTK W&B	T15 Flash	T15 W&B		
Temperature	°F	87.1752	90 *	93.8273		
Pressure	psia	9.75476	13.28 *	9.57979		
Mole Fraction Vapor	%	100	100	100		
Mole Fraction Light Liquid	%	0	0	0		
Mole Fraction Heavy Liquid	%	0	0	0		
Molecular Weight	lb/lbmol	42.5053	42.1661	41.9546		
Mass Density	lb/ft^3	0.0709201	0.0954001	0.0679068		
Molar Flow	lbmol/h	18.0714	0.688201	17.8422		
Mass Flow	lb/h	768.133	29.0187	748.563		
Vapor Volumetric Flow	ft^3/h	10831	304.179	11023.4		
Liquid Volumetric Flow	gpm	1350.35	37.9237	1374.34		
Std Vapor Volumetric Flow	MMSCFD	0.164588	0.00626787	0.1625		
Std Liquid Volumetric Flow	sgpm	1.87599	0.0730331	1.82093		

* User Specified Values

? Extrapolated or Approximate Values

ProMax 5.0.20169.0
Copyright © 2002-2020 BRE Group, Ltd.

Licensed to Portnoy Environmental, Inc. and Affiliates

Process Streams Report All Streams Tabulated by Total Phase						
Client Name:	ConocoPhillips				Job: Tank Battery Emissions	
Location:						
Flowsheet:	Separations					
Stream Properties						
Property	Units	SKTK W&B	T15 Flash	T15 W&B		
Compressibility		0.996237	0.995055	0.996422		
Specific Gravity		1.4676	1.45588	1.44858		
API Gravity						
Enthalpy	Btu/h	-2.91516E+06	-108137	-2.86108E+06		
Mass Enthalpy	Btu/lb	-3795.12	-3726.45	-3822.1		
Mass Cp	Btu/(lb*°F)	0.213649	0.219926	0.214887		
Ideal Gas CpCv Ratio		1.28133	1.2743	1.28386		
Dynamic Viscosity	cP	0.0151198	0.0149952	0.0153155		
Kinematic Viscosity	cSt	13.3093	9.81257	14.0798		
Thermal Conductivity	Btu/(h*ft*°F)	0.00975613	0.0100722	0.00994559		
Surface Tension	lbf/ft					
Net Ideal Gas Heating Value	Btu/ft^3	46.9089	106.799	32.8754		
Net Liquid Heating Value	Btu/lb	313.535	860.495	184.989		
Gross Ideal Gas Heating Value	Btu/ft^3	53.4258	118.588	38.988		
Gross Liquid Heating Value	Btu/lb	371.716	966.609	240.277		
Remarks						

User Value Sets Report		
-------------------------------	--	--

Client Name:	ConocoPhillips	Job: Tank Battery Emissions
Location:		

Sales Tank		
-------------------	--	--

User Value [MaxAvgT]		
-----------------------------	--	--

* Parameter	77.225 °F	Upper Bound	°F
Lower Bound	°F	* Enforce Bounds	False

User Value [MinAvgT]		
-----------------------------	--	--

* Parameter	49.325 °F	Upper Bound	°F
Lower Bound	°F	* Enforce Bounds	False

User Value [MaxVP]		
---------------------------	--	--

* Parameter	12.1026 psia	Upper Bound	psia
Lower Bound	psia	* Enforce Bounds	False

User Value [MinVP]		
---------------------------	--	--

* Parameter	9.0926 psia	Upper Bound	psia
Lower Bound	psia	* Enforce Bounds	False

Remarks
 This User Value Set was programmatically generated. GUID={8BEF1AFB-B2FB-4747-8315-70D75C99B65D}

Surge Tank		
-------------------	--	--

User Value [MaxAvgT]		
-----------------------------	--	--

* Parameter	77.225 °F	Upper Bound	°F
Lower Bound	°F	* Enforce Bounds	False

User Value [MinAvgT]		
-----------------------------	--	--

* Parameter	49.325 °F	Upper Bound	°F
Lower Bound	°F	* Enforce Bounds	False

User Value [MaxVP]		
---------------------------	--	--

* Parameter	12.1105 psia	Upper Bound	psia
Lower Bound	psia	* Enforce Bounds	False

User Value [MinVP]		
---------------------------	--	--

* Parameter	9.11098 psia	Upper Bound	psia
Lower Bound	psia	* Enforce Bounds	False

Remarks
 This User Value Set was programmatically generated. GUID={8B171106-31FC-41F9-BBB5-963DCAA72D5B}

Overflow Oil T12		
-------------------------	--	--

User Value [MaxAvgT]		
-----------------------------	--	--

* Parameter	77.225 °F	Upper Bound	°F
Lower Bound	°F	* Enforce Bounds	False

User Value [MinAvgT]		
-----------------------------	--	--

* Parameter	49.325 °F	Upper Bound	°F
Lower Bound	°F	* Enforce Bounds	False

User Value [MaxVP]		
---------------------------	--	--

* Parameter	12.1101 psia	Upper Bound	psia
-------------	--------------	-------------	------

* User Specified Values
 ? Extrapolated or Approximate Values

User Value Sets Report

Client Name:	ConocoPhillips	Job: Tank Battery Emissions
Location:		

User Value [MaxVP]

Lower Bound	psia	* Enforce Bounds	False
-------------	------	------------------	-------

User Value [MinVP]

* Parameter	9.10482	psia	Upper Bound	psia
Lower Bound			* Enforce Bounds	False

Remarks
 This User Value Set was programmatically generated. GUID={A0AE4492-FC19-4390-B4C3-8E57364ECBAF}

Skim Tank (T-11)

User Value [MaxAvgT]

* Parameter	77.225	°F	Upper Bound	°F
Lower Bound			* Enforce Bounds	False

User Value [MinAvgT]

* Parameter	49.325	°F	Upper Bound	°F
Lower Bound			* Enforce Bounds	False

User Value [MaxVP]

* Parameter	13.282	psia	Upper Bound	psia
Lower Bound			* Enforce Bounds	False

User Value [MinVP]

* Parameter	10.5332	psia	Upper Bound	psia
Lower Bound			* Enforce Bounds	False

Remarks
 This User Value Set was programmatically generated. GUID={4F977F4F-7D0C-4647-AAA0-6F79B1D38004}

Produced Water Tank (T-15)

User Value [MaxAvgT]

* Parameter	77.225	°F	Upper Bound	°F
Lower Bound			* Enforce Bounds	False

User Value [MinAvgT]

* Parameter	49.325	°F	Upper Bound	°F
Lower Bound			* Enforce Bounds	False

User Value [MaxVP]

* Parameter	13.282	psia	Upper Bound	psia
Lower Bound			* Enforce Bounds	False

User Value [MinVP]

* Parameter	10.5994	psia	Upper Bound	psia
Lower Bound			* Enforce Bounds	False

Remarks
 This User Value Set was programmatically generated. GUID={E1410EF7-AF52-4998-9066-0B20506999B8}

* User Specified Values
 ? Extrapolated or Approximate Values

Solar Turbines

A Caterpillar Company

Solar Turbines Incorporated

2626 John Ben Shepperd Parkway
Building B, Suite 110
Odessa, TX 79761-1947
(915) 367-5055
(915) 550-5070
1 (800) 851-6594
Fax: (915) 367-9523

April 28, 2000

Phillips Petroleum Company
4001 Penbrook Street
Odessa, Texas 79762

Attn: Mr. Henry Platt

SUBJECT: SOLAR SATURN T1200 EMISSIONS

Dear Mr. Platt:

The expect emission level provided for the T1200 turbine engines located at Buckeye, NM, does not list a maximum level, as the model engine is currently out of production.

The maximum level would normally be 120% of nominal levels.

If I can be further service, please do not hesitate to call.

Regards,

Russ Sylvester
District Manager
Customer Service Sales

SOLAR TURBINES INCORPORATED
 ENGINE PERFORMANCE CODE REV. 2.85
 CUSTOMER: Phillips Pet.Buckeye
 E ID: 0000

DATE RUN: 24-APR-00
 RUN BY: Russ Sylvester

NEW EQUIPMENT PREDICTED EMISSION PERFORMANCE
 DATA FOR POINT NUMBER 1

Fuel: SD NATURAL GAS Customer: Phillips Pet.Buckeye
 Water Injection: NO Inquiry Number: 0000
 Number of Engines Tested: 5
 Model: SATURN 10-T1200 CS/MD STANDARD GAS
 Emissions Data: REV. 0.0

CRITICAL WARNINGS IN USE OF DATA FOR PERMITTING

1. Short term permitting values such as PPMV or lbs/hr should be based on worst case actual operating conditions specific to the application and the site. Worst case for one pollutant is not necessarily the same for another. The values on this form are only predicted emissions at one specific operating condition; not necessarily the worst case.
2. Long term reference emission units (e.g. tons/yr) should reference the average conditions at the site (e.g. ISO). That number should not be derived from the worst case value referenced above, or conversely this average must not be used to calculate worst case.
3. Nominal values are based on actual test results, or predicted in the case of no actual engine tests. Expected maximum values should be referenced for permitting.
4. If a SoLoNOx model is planned to be installed in the future, use no less than 50 PPMV CO.

The following predicted emissions performance is based on the following specific single point: (see attached)

Hp= 1081, %Full Load= 100.0, Elev= 3000 ft, %RH= 60.0, Temperature= 40.0 F

NOX		CO		UHC		
NOM	MAX	NOM	MAX	NOM	MAX	
58.82	**	105.45	**	28.717	**	PPMvd at 15% O2
12.22	**	13.46	**	2.080	**	ton/yr
0.235	**	0.258	**	0.0399	**	lbm/MMBtu (Fuel LHV)
3.46	**	3.81	**	0.589	**	lbm/(MW-hr) (gas turbine shaft pwr)

** PLEASE SUBMIT SPECIAL ENGINE REQUEST FOR GUARANTEE EMISSION VALUES

 NO GUARANTEE EMISSION DATABASE AVAILABLE FOR THIS ENGINE

OTHER IMPORTANT NOTES

1. Solar does not provide maximum values for water-to-fuel ratio, SOX, particulates, or conditions outside those above without separate written approval.
2. Solar can optionally provide factory testing in San Diego to ensure the actual unit(s) meet the above values within the tolerances quoted. Pricing and schedule impact will be provided upon request.
3. Fuel must meet Solar standard fuel specification ES 9-98. Predicted

emissions are based on the attached fuel composition, or, San Diego natural gas or equivalent.

4. If the above information is being used regarding existing equipment, it should be verified by actual site testing.

SOLAR TURBINES INCORPORATED
 ENGINE PERFORMANCE CODE REV. 2.85
 CUSTOMER: Phillips Pet.Buckeye
 ID: 0000

DATE RUN: 24-APR-00
 RUN BY: Russ Sylvester

SATURN 10-T1200
 CS/MD
 STANDARD
 GAS
 TSB-2 REV. 0.0

DATA FOR NOMINAL PERFORMANCE

Fuel Type		SD	NATURAL	GAS
Elevation	Feet	3000		
Inlet Loss	in. H2O	3.0		
Exhaust Loss	in. H2O	3.0		
Engine Inlet Temp.	Deg. F	40.0	59.0	90.0
Relative Humidity	%	60.0	60.0	60.0
Elevation Loss	Hp	124	115	102
Inlet Loss	Hp	18	17	16
Exhaust Loss	Hp	10	9	9
Driven Equipment Speed	RPM	22300	22238	21870
Minimum Equipment Speed	RPM	22300	22238	21870
Generator Speed	RPM	22300	22300	22300
Specified Load	Hp	FULL	FULL	FULL
Net Output Power	Hp	1081	1045	956
Fuel Flow	MMBtu/hr	11.89	11.57	10.93
Heat Rate	Btu/Hp-hr	10998	11075	11433
Inlet Air Flow	lbm/hr	45236	43924	41064
Engine Exhaust Flow	lbm/hr	45732	44407	41520
PCD	psi(g)	68.9	67.2	62.6
PT Inlet Temp. (T5)	Deg. F	1041	1055	1078
Compensated PTIT	Deg. F	1041	1055	1078
Exhaust Temperature	Deg. F	818	840	876

Table 3.1-3. EMISSION FACTORS FOR HAZARDOUS AIR POLLUTANTS FROM NATURAL GAS-FIRED STATIONARY GAS TURBINES^a

Emission Factors ^b - Uncontrolled		
Pollutant	Emission Factor (lb/MMBtu) ^c	Emission Factor Rating
1,3-Butadiene ^d	< 4.3 E-07	D
Acetaldehyde	4.0 E-05	C
Acrolein	6.4 E-06	C
Benzene ^e	1.2 E-05	A
Ethylbenzene	3.2 E-05	C
Formaldehyde ^f	7.1 E-04	A
Naphthalene	1.3 E-06	C
PAH	2.2 E-06	C
Propylene Oxide ^d	< 2.9 E-05	D
Toluene	1.3 E-04	C
Xylenes	6.4 E-05	C

^a SCC for natural gas-fired turbines include 2-01-002-01, 2-02-002-01, 2-02-002-03, 2-03-002-02, and 2-03-002-03. Hazardous Air Pollutants as defined in Section 112 (b) of the *Clean Air Act*.

^b Factors are derived from units operating at high loads (≥ 80 percent load) only. For information on units operating at other loads, consult the background report for this chapter (Reference 16), available at “www.epa.gov/ttn/chief”.

^c Emission factors based on an average natural gas heating value (HHV) of 1020 Btu/scf at 60°F. To convert from (lb/MMBtu) to (lb/10⁶ scf), multiply by 1020. These emission factors can be converted to other natural gas heating values by multiplying the given emission factor by the ratio of the specified heating value to this heating value.

^d Compound was not detected. The presented emission value is based on one-half of the detection limit.

^e Benzene with SCONOX catalyst is 9.1 E-07, rating of D.

^f Formaldehyde with SCONOX catalyst is 2.0 E-05, rating of D.

FIG. 15-33 (Cont'd)
Mechanical Drives - 1982 Performance Specifications

series designation	1st year unit was available		output shaft speed		at continuous rating		Excerpted with Permission from Gas Turbine World				
	Year	ISO Rating Continuous (hp)	Heat Rate (Btu/shp-hr)	Air Flow (lb/sec)	Turbine Speed	Pressure Ratio	Turbine Inlet Temp	Exhaust Temp	Dry Weight (Approx)	Length x Width x Height (Approx)	Comments and Footnotes
Kvaerner Brug	1981	17600 hp	7940 Btu/shp-hr	125 lb/sec	3000 rpm	18.0	—	775°F	27500 kg	29 x 10 x 12 ft	gas fuel rating
	1978	27500 hp	6895 Btu/shp-hr	144 lb/sec	3600 rpm	18.0	2100°F	922°F	27500 kg	29 x 10 x 12 ft	gas fuel rating
	1972	26250 hp	9780 Btu/shp-hr	215 lb/sec	4670 rpm	6.9	1650°F	945°F	117000 kg	50 x 10 x 12 ft	gas fuel rating
	1972	25600 hp	9840 Btu/shp-hr	215 lb/sec	4670 rpm	6.9	1690°F	975°F	117000 kg	50 x 10 x 12 ft	distillate fuel rating
	1972	35000 hp	8830 Btu/shp-hr	268 lb/sec	4670 rpm	8.3	1700°F	915°F	117000 kg	50 x 10 x 12 ft	gas fuel rating
	1972	34050 hp	9010 Btu/shp-hr	268 lb/sec	4670 rpm	8.3	1700°F	915°F	117000 kg	50 x 10 x 12 ft	distillate fuel rating
Pratt & Whitney Aircraft Canada	1968	510 hp	12328 Btu/shp-hr	6.0 lb/sec	2200/6230	6.2	1555°F	928°F	350/317 lb	5 x 2 x 2 ft	"K" models w. 6230 rpm output
	1972	550 hp	12199 Btu/shp-hr	5.9 lb/sec	2200/6230	6.9	1605°F	983°F	369/340 lb	5 x 2 x 2 ft	
	1971	654 hp	11371 Btu/shp-hr	6.2 lb/sec	33000 rpm	7.1	1700°F	1022°F	306 lb	4 x 2 x 2 ft	
	1976	840 hp	11400 Btu/shp-hr	7.8 lb/sec	30000 rpm	8.5	1735°F	1015°F	360 lb	5 x 2 x 2 ft	
	1975	1440 hp	11960 Btu/shp-hr	12.7 lb/sec	6600 rpm	7.7	1765°F	1075°F	740 lb	6 x 4 x 3 ft	
	Rolls-Royce	1976	*19100 eghp	6405 Btu/ghp-hr	129 lb/sec	—	18.5	1810°F	1090°F	3250 lb	9 x 4 x 5 ft
1964		*19580 eghp	7634 Btu/ghp-hr	168 lb/sec	—	8.8	1490°F	1020°F	3560 lb	11.5 x 3 x 3 ft	gas generator only
1970		*21890 eghp	7570 Btu/ghp-hr	168 lb/sec	—	8.8	1620°F	1120°F	3560 lb	11.5 x 3 x 3 ft	gas generator only
1975		*23800 eghp	7506 Btu/ghp-hr	170 lb/sec	—	9.0	1690°F	1170°F	3560 lb	11.5 x 3 x 3 ft	gas generator only
1974		*34000 eghp	6325 Btu/ghp-hr	196 lb/sec	—	18.4	2015°F	1240°F	5700 lb	10 x 5 x 5 ft	gas generator only
1977		37800 eghp	8300 Btu/ghp-hr	238 lb/sec	3000/3600	11.0	*1455°F	1015°F	515000 lb	76 x 14 x 49 ft	packaged plant
Ruston Gas Turbines	1969	1875 hp	13950 Btu/hp-hr	25 lb/sec	6600 rpm	4.3	1516°F	979°F	22500 lb	16 x 8 x 8.5 ft	
	1978	2500 hp	12000 Btu/hp-hr	28 lb/sec	7950 rpm	4.9	1564°F	944°F	20000 lb	19 x 8 x 8.5 ft	
	1977	4900 hp	9980 Btu/hp-hr	46 lb/sec	7950 rpm	7.0	1633°F	944°F	30000 lb	19 x 8 x 8 ft	
	1982	8500 hp	8120 Btu/hp-hr	60 lb/sec	10000 rpm	12.0	1832°F	887°F	42000 lb	24 x 8 x 9.5 ft	
Solar turbines	1960	1160 hp	11500 Btu/hp-hr	19 lb/sec	22300 rpm	6.2	1450°F	860°F	8230 lb	13 x 6 x 6.5 ft	
	1968	3880 hp	9590 Btu/hp-hr	38 lb/sec	15700 rpm	8.3	1600°F	800°F	23000 lb	21 x 8 x 8.5 ft	
	1977	10600 hp	7770 Btu/hp-hr	80 lb/sec	9500 rpm	16.0	1826°F	785°F	60000 lb	34 x 8 x 9 ft	
	1976	7770 hp	9430 Btu/hp-hr	70 lb/sec	10600 rpm	8.9	970°C	505°C	60000 lb	24 x 10 x 9 ft	
Sulzer Brothers	1976	7460 hp	7710 Btu/hp-hr	70 lb/sec	10600 rpm	9.0	970°C	391°C	60000 lb	24 x 10 x 9 ft	
	1970	14200 hp	10180 Btu/hp-hr	140 lb/sec	6400 rpm	7.6	925°C	491°C	155000 lb	41 x 12 x 13 ft	
	1970	13600 hp	8030 Btu/hp-hr	140 lb/sec	6400 rpm	7.7	925°C	342°C	156000 lb	41 x 12 x 13 ft	
	1981	27800 hp	7690 Btu/hp-hr	158 lb/sec	7700 rpm	13.5	—	507°C	61700 lb	26 x 10 x 11 ft	
	1978	16350 hp	8990 Btu/hp-hr	166 lb/sec	6500 rpm	8.8	810°C	403°C	62000 lb	40 x 14 x 13 ft	Avon 1533 gas gen
	1978	18360 hp	8900 Btu/hp-hr	166 lb/sec	6500 rpm	8.8	883°C	440°C	62000 lb	40 x 14 x 13 ft	Avon 1534 gas gen
	1978	19970 hp	8840 Btu/hp-hr	168 lb/sec	6500 rpm	9.0	923°C	459°C	62000 lb	40 x 14 x 13 ft	Avon 1535 gas gen
	1979	28140 hp	7620 Btu/hp-hr	193 lb/sec	6500 rpm	18.4	1102°C	453°C	64000 lb	35 x 14 x 13 ft	RB.211 gas gen
	S3	7770 hp	9430 Btu/hp-hr	70 lb/sec	10600 rpm	8.9	970°C	505°C	60000 lb	24 x 10 x 9 ft	
	SR3	7460 hp	7710 Btu/hp-hr	70 lb/sec	10600 rpm	9.0	970°C	391°C	60000 lb	24 x 10 x 9 ft	
	S7	14200 hp	10180 Btu/hp-hr	140 lb/sec	6400 rpm	7.6	925°C	491°C	155000 lb	41 x 12 x 13 ft	

*Note: Multiply exhaust gas horsepower (eghp) by typical power turbine efficiency of 85% to estimate equivalent shaft horsepower (shp).

* power turbine inlet temp.

Table 3.2-2. UNCONTROLLED EMISSION FACTORS FOR 4-STROKE LEAN-BURN ENGINES
(Continued)

Pollutant	Emission Factor (lb/MMBtu) ^b (fuel input)	Emission Factor Rating
Acenaphthylene ^k	5.53 E-06	C
Acetaldehyde ^{k,l}	8.36 E-03	A
Acrolein ^{k,l}	5.14 E-03	A
Benzene ^k	4.40 E-04	A
Benzo(b)fluoranthene ^k	1.66 E-07	D
Benzo(e)pyrene ^k	4.15 E-07	D
Benzo(g,h,i)perylene ^k	4.14 E-07	D
Biphenyl ^k	2.12 E-04	D
Butane	5.41 E-04	D
Butyr/Isobutyraldehyde	1.01 E-04	C
Carbon Tetrachloride ^k	<3.67 E-05	E
Chlorobenzene ^k	<3.04 E-05	E
Chloroethane	1.87 E-06	D
Chloroform ^k	<2.85 E-05	E
Chrysene ^k	6.93 E-07	C
Cyclopentane	2.27 E-04	C
Ethane	1.05 E-01	C
Ethylbenzene ^k	3.97 E-05	B
Ethylene Dibromide ^k	<4.43 E-05	E
Fluoranthene ^k	1.11 E-06	C
Fluorene ^k	5.67 E-06	C
Formaldehyde ^{k,l}	5.28 E-02	A
Methanol ^k	2.50 E-03	B
Methylcyclohexane	1.23 E-03	C
Methylene Chloride ^k	2.00 E-05	C
n-Hexane ^k	1.11 E-03	C
n-Nonane	1.10 E-04	C

Table 1.4-1. EMISSION FACTORS FOR NITROGEN OXIDES (NO_x) AND CARBON MONOXIDE (CO)
FROM NATURAL GAS COMBUSTION^a

Combustor Type (MMBtu/hr Heat Input) [SCC]	NO _x ^b		CO	
	Emission Factor (lb/10 ⁶ scf)	Emission Factor Rating	Emission Factor (lb/10 ⁶ scf)	Emission Factor Rating
Large Wall-Fired Boilers (>100) [1-01-006-01, 1-02-006-01, 1-03-006-01]				
Uncontrolled (Pre-NSPS) ^c	280	A	84	B
Uncontrolled (Post-NSPS) ^c	190	A	84	B
Controlled - Low NO _x burners	140	A	84	B
Controlled - Flue gas recirculation	100	D	84	B
Small Boilers (<100) [1-01-006-02, 1-02-006-02, 1-03-006-02, 1-03-006-03]				
Uncontrolled	100	B	84	B
Controlled - Low NO _x burners	50	D	84	B
Controlled - Low NO _x burners/Flue gas recirculation	32	C	84	B
Tangential-Fired Boilers (All Sizes) [1-01-006-04]				
Uncontrolled	170	A	24	C
Controlled - Flue gas recirculation	76	D	98	D
Residential Furnaces (<0.3) [No SCC]				
Uncontrolled	94	B	40	B

^a Reference 11. Units are in pounds of pollutant per million standard cubic feet of natural gas fired. To convert from lb/10⁶ scf to kg/10⁶ m³, multiply by 16. Emission factors are based on an average natural gas higher heating value of 1,020 Btu/scf. To convert from lb/10⁶ scf to lb/MMBtu, divide by 1,020. The emission factors in this table may be converted to other natural gas heating values by multiplying the given emission factor by the ratio of the specified heating value to this average heating value. SCC = Source Classification Code. ND = no data. NA = not applicable.

^b Expressed as NO₂. For large and small wall fired boilers with SNCR control, apply a 24 percent reduction to the appropriate NO_x emission factor. For tangential-fired boilers with SNCR control, apply a 13 percent reduction to the appropriate NO_x emission factor.

^c NSPS=New Source Performance Standard as defined in 40 CFR 60 Subparts D and Db. Post-NSPS units are boilers with greater than 250 MMBtu/hr of heat input that commenced construction modification, or reconstruction after August 17, 1971, and units with heat input capacities between 100 and 250 MMBtu/hr that commenced construction modification, or reconstruction after June 19, 1984.

TABLE 1.4-2. EMISSION FACTORS FOR CRITERIA POLLUTANTS AND GREENHOUSE GASES FROM NATURAL GAS COMBUSTION^a

Pollutant	Emission Factor (lb/10 ⁶ scf)	Emission Factor Rating
CO ₂ ^b	120,000	A
Lead	0.0005	D
N ₂ O (Uncontrolled)	2.2	E
N ₂ O (Controlled-low-NO _x burner)	0.64	E
PM (Total) ^c	7.6	D
PM (Condensable) ^c	5.7	D
PM (Filterable) ^c	1.9	B
SO ₂ ^d	0.6	A
TOC	11	B
Methane	2.3	B
VOC	5.5	C

^a Reference 11. Units are in pounds of pollutant per million standard cubic feet of natural gas fired. Data are for all natural gas combustion sources. To convert from lb/10⁶ scf to kg/10⁶ m³, multiply by 16. To convert from lb/10⁶ scf to lb/MMBtu, divide by 1,020. The emission factors in this table may be converted to other natural gas heating values by multiplying the given emission factor by the ratio of the specified heating value to this average heating value. TOC = Total Organic Compounds.

VOC = Volatile Organic Compounds.

^b Based on approximately 100% conversion of fuel carbon to CO₂. CO₂[lb/10⁶ scf] = (3.67) (CON) (C)(D), where CON = fractional conversion of fuel carbon to CO₂, C = carbon content of fuel by weight (0.76), and D = density of fuel, 4.2x10⁴ lb/10⁶ scf.

^c All PM (total, condensable, and filterable) is assumed to be less than 1.0 micrometer in diameter. Therefore, the PM emission factors presented here may be used to estimate PM₁₀, PM_{2.5} or PM₁ emissions. Total PM is the sum of the filterable PM and condensable PM. Condensable PM is the particulate matter collected using EPA Method 202 (or equivalent). Filterable PM is the particulate matter collected on, or prior to, the filter of an EPA Method 5 (or equivalent) sampling train.

^d Based on 100% conversion of fuel sulfur to SO₂.

Assumes sulfur content is natural gas of 2,000 grains/10⁶ scf. The SO₂ emission factor in this table can be converted to other natural gas sulfur contents by multiplying the SO₂ emission factor by the ratio of the site-specific sulfur content (grains/10⁶ scf) to 2,000 grains/10⁶ scf.

EMISSION LEVELS

VHP:

MODEL	CARBURETOR SETTING	GRAMS/HP-HR				% OBSERVED DRY		MASS AFR**	VOLUME AFR**	EXCESS AIR RATIO
		NOX*	CO	NMHC	THC	CO	O2			
G,GSI	Lowest Manifold (Best Power)	7.0	28.0	0.30	2.0	1.15	0.30	15.5:1	9.3:1	0.97
G,GSI	Equal NOx & CO	10.0	10.0	0.30	2.0	0.45	0.30	15.9:1	9.6:1	0.99
G,GSI	Catalytic Conv. Input (3- way***)	11.0	8.0	0.25	1.7	0.38	0.30	15.95:1	9.6:1	0.99
G,GSI	Normal (Best Economy)	18.0	1.0	0.20	1.0	0.02	1.35	17.0:1	10.2:1	1.06
GL	Normal	1.5	2.65	1.0	5.5	0.06	9.8	28.0:1	16.8:1	1.74

ATGL:

MODEL	CARBURETOR SETTING	GRAMS/HP-HR				% OBSERVED DRY		MASS AFR**	VOLUME AFR**	EXCESS AIR RATIO
		NOX*	CO	NMHC	THC	CO	O2			
AT25GL	Normal	1.0	2.25	1.0	8.0	0.06	9.8	28.0:1	16.8:1	1.74
AT27GL	Normal	1.5	1.70	0.5	5.0	0.06	9.8	28.0:1	16.8:1	1.74
AT27GL	Ultra Lean	1.5	2.0	0.6	6.0	.005	11.4	32.0:1	19.2:1	2.00

Table 3.3-1. EMISSION FACTORS FOR UNCONTROLLED GASOLINE AND DIESEL INDUSTRIAL ENGINES^a

Pollutant	Gasoline Fuel (SCC 2-02-003-01, 2-03-003-01)		Diesel Fuel (SCC 2-02-001-02, 2-03-001-01)		EMISSION FACTOR RATING
	Emission Factor (lb/hp-hr) (power output)	Emission Factor (lb/MMBtu) (fuel input)	Emission Factor (lb/hp-hr) (power output)	Emission Factor (lb/MMBtu) (fuel input)	
NO _x	0.011	1.63	0.031	4.41	D
CO	0.439	62.7	6.68 E-03	0.95	D
SO _x	5.91 E-04	0.084	2.05 E-03	0.29	D
PM-10 ^b	7.21 E-04	0.10	2.20 E-03	0.31	D
CO ₂ ^c	1.08	154	1.15	164	B
Aldehydes	4.85 E-04	0.07	4.63 E-04	0.07	D
TOC					
Exhaust	0.015	2.10	2.47 E-03	0.35	D
Evaporative	6.61 E-04	0.09	0.00	0.00	E
Crankcase	4.85 E-03	0.69	4.41 E-05	0.01	E
Refueling	1.08 E-03	0.15	0.00	0.00	E

^a References 2,5-6,9-14. When necessary, an average brake-specific fuel consumption (BSFC) of 7,000 Btu/hp-hr was used to convert from lb/MMBtu to lb/hp-hr. To convert from lb/hp-hr to kg/kw-hr, multiply by 0.608. To convert from lb/MMBtu to ng/J, multiply by 430. SCC = Source Classification Code. TOC = total organic compounds.

^b PM-10 = particulate matter less than or equal to 10 µm aerodynamic diameter. All particulate is assumed to be ≤ 1 µm in size.

^c Assumes 99% conversion of carbon in fuel to CO₂ with 87 weight % carbon in diesel, 86 weight % carbon in gasoline, average BSFC of 7,000 Btu/hp-hr, diesel heating value of 19,300 Btu/lb, and gasoline heating value of 20,300 Btu/lb.

Table A-6. TCEQ Air Permits Flare Emission Factors

Contaminant	Assist Type	Waste Gas Stream Net Heating Value ^{a,b}	Emission Factor
NO _x	Steam	High Btu	0.0485 lb/MMBtu
		Low Btu	0.068 lb/MMBtu
	Air or Unassisted	High Btu	0.138 lb/MMBtu
		Low Btu	0.0641 lb/MMBtu
CO	Steam	High Btu	0.3503 lb/MMBtu
		Low Btu	0.3465 lb/MMBtu
	Air or Unassisted	High Btu	0.2755 lb/MMBtu
		Low Btu	0.5496 lb/MMBtu

^a High Btu: > 1000 Btu/scf

^b Low Btu: 192–1000 Btu/scf

Calculate emissions using the most accurate data for the gas flow rate and composition available. (See “Flared Gas Flow Rate and Composition” earlier in this supplement for more information on preferred data.)

Regardless of the data’s source, the determination methodology for NO_x and CO emissions must be reported as “A” for ‘TCEQ-approved factor.’

For flares subject to the HRVOC regulations in Chapter 115, Subchapter H, use the net heating value data required by 30 TAC 115.725 and 115.726 to determine NO_x and CO emissions for any portions of 2011 during which HRVOC monitors were installed and operational.

Uncombusted Flared Gas Emissions

Uncombusted flared gas emissions usually include VOCs, H₂S, or both. Emissions calculations for these contaminants are based on the flared gas flow rate and composition, and the appropriate destruction efficiency, which depends upon the actual flare operation.

Destruction Efficiencies

Flare destruction efficiency varies with flame stability, operating conditions, flare tip size and design, the specific compounds being combusted, and gas composition. The EPA has determined operating limits (see 40 CFR 60.18), that result in stable operation of flare flames. Therefore, emission determinations may vary depending on whether the criteria of 40 CFR 60.18 are satisfied. Chapter 115 HRVOC regulations address flare operational requirements in regard to 40 CFR 60.18. For

Tab 8
Section 8 - Map(s)

Section 8

Map(s)

A map such as a 7.5 minute topographic quadrangle showing the exact location of the source. The map shall also include the following:

The UTM or Longitudinal coordinate system on both axes	An indicator showing which direction is north
A minimum radius around the plant of 0.8km (0.5 miles)	Access and haul roads
Topographic features of the area	Facility property boundaries
The name of the map	The area which will be restricted to public access
A graphical scale	

A site location map and an aerial image are included. The property boundary is indicated by the black and red borders. The red border indicates an area with restricted access.

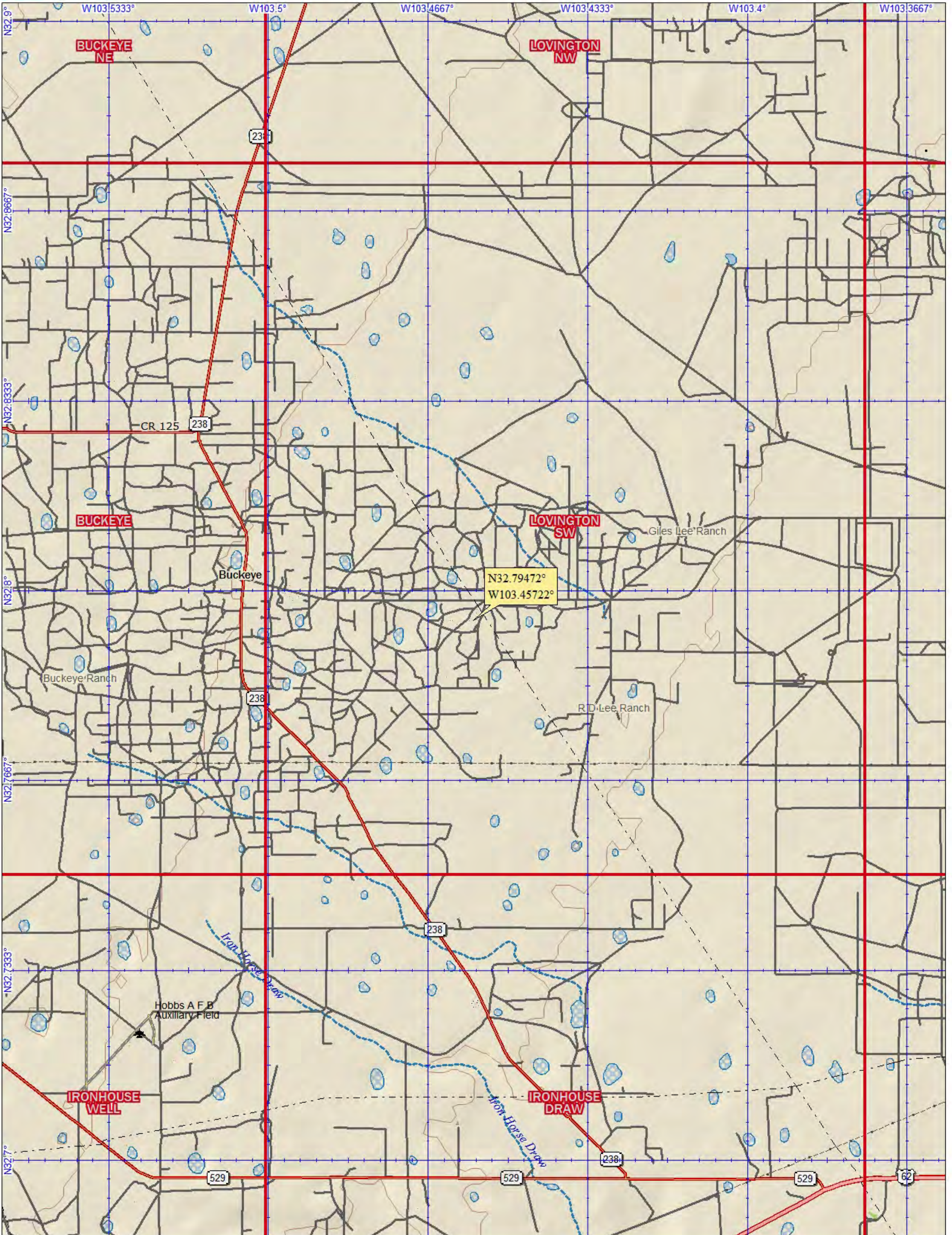

Data use subject to license.

© DeLorme. DeLorme Topo USA® 7.0.

www.delorme.com



Data Zoom 11-0

EVLRP

Aerial Image with 0.5 Mile Boundary and Access Roads

Legend

 EVLRP and CTB

Buckeye Rd

50

Vacuum Complex Ln

EVLRP and CTB

Google Earth

© 2020 Google

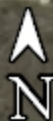

3000 ft

Tab 9
Section 9 - Proof of Public Notice

Section 9

Proof of Public Notice

(for NSR applications submitting under 20.2.72 or 20.2.74 NMAC)

(This proof is required by: 20.2.72.203.A.14 NMAC “Documentary Proof of applicant’s public notice”)

I have read the AQB “Guidelines for Public Notification for Air Quality Permit Applications”

This document provides detailed instructions about public notice requirements for various permitting actions. It also provides public notice examples and certification forms. Material mistakes in the public notice will require a re-notice before issuance of the permit.

Unless otherwise allowed elsewhere in this document, the following items document proof of the applicant’s Public Notification. Please include this page in your proof of public notice submittal with checkmarks indicating which documents are being submitted with the application.

New Permit and **Significant Permit Revision** public notices must include all items in this list.

Technical Revision public notices require only items 1, 5, 9, and 10.

Per the Guidelines for Public Notification document mentioned above, include:

1. A copy of the certified letter receipts with post marks (20.2.72.203.B NMAC)
2. A list of the places where the public notice has been posted in at least four publicly accessible and conspicuous places, including the proposed or existing facility entrance. (e.g: post office, library, grocery, etc.)
3. A copy of the property tax record (20.2.72.203.B NMAC). **SEE NOTE BELOW**
4. A sample of the letters sent to the owners of record.
5. A sample of the letters sent to counties, municipalities, and Indian tribes.
6. A sample of the public notice posted and a verification of the local postings.
7. A table of the noticed citizens, counties, municipalities and tribes and to whom the notices were sent in each group.
8. A copy of the public service announcement (PSA) sent to a local radio station and documentary proof of submittal.
9. A copy of the classified or legal ad including the page header (date and newspaper title) or its affidavit of publication stating the ad date, and a copy of the ad. When appropriate, this ad shall be printed in both English and Spanish.
10. A copy of the display ad including the page header (date and newspaper title) or its affidavit of publication stating the ad date, and a copy of the ad. When appropriate, this ad shall be printed in both English and Spanish.
11. A map with a graphic scale showing the facility boundary and the surrounding area in which owners of record were notified by mail. This is necessary for verification that the correct facility boundary was used in determining distance for notifying land owners of record.

Public notice is not required of COP for Title V applications.

Tab 10

**Section 10 - Written Description of the Routine
Operations of the Facility**

Section 10

Written Description of the Routine Operations of the Facility

A written description of the routine operations of the facility. Include a description of how each piece of equipment will be operated, how controls will be used, and the fate of both the products and waste generated. For modifications and/or revisions, explain how the changes will affect the existing process. In a separate paragraph describe the major process bottlenecks that limit production. The purpose of this description is to provide sufficient information about plant operations for the permit writer to determine appropriate emission sources.

EVL RP utilizes CO₂ injection as a recovery technique to enhance oil production. The produced gas from surrounding batteries and satellite facilities enters the plant at produced gas scrubbers that removes heavy hydrocarbons and water from the gas and transfers these liquids to the central tank battery. Additional heavy ends are separated from the produced gas in the suction scrubbers, which are also transferred to the central tank battery.

The plant has two operating trains, with one operating at up to 25 million standard cubic feet per day (MMscfd) and one operating at up to 20 MMscfd. The 25MMscfd train dehydrates the gas and extracts natural gas liquids (NGLs) from the gas, while the 20 MMscfd train only dehydrates the gas. In both trains, the gas is compressed via electric-drive compressors.

In the 25 MMscfd train, the compressor discharge flows to a glycol knockout vessel that separates it into three phases: water, natural gas liquids (NGL), and gas. Water from the knockout vessel dumps to the central tank battery. The NGL is pumped to a contactor vessel where glycol is used to remove excess moisture. Dry NGL flows to the propane recovery column (PRC). The gas stream from the glycol knockout vessel then flows to a contactor vessel to be further dehydrated. The overhead gas stream from the glycol contactor then flows to a molecular sieve dehydration system. Rich glycol from the gas contactor and rich glycol from the NGL contactor flow to the TEG regeneration system (DEHY1). Emissions from the dehydrator still vent will be routed back to the produced gas separator, with no emissions to the atmosphere. Emissions from DEHY1 in the application are associated with the glycol regenerator heater.

Dehydrated gas from the mole sieve dehydration system is fed to the propane recovery column (PRC). The PRC overhead stream consists of lighter components such as ethane, methane, carbon dioxide, and H₂S. This stream is cooled and condensed in the PRC condenser via propane from the refrigeration system and is then pumped to a scrubber. Refrigerant compression is provided by units 16 and 17. The overhead gas stream from the scrubber, which is primarily CO₂ is compressed and reinjected into the producing wells along with purchased CO₂. Reinjection compression is provided by electric-drive compressors. Scrubber liquids are diverted to the pressurized sour NGL storage tanks (Units 37 and 38). If the gas is not reinjected, it is flared (Unit 19).

Liquid bottoms from the PRC consist of propane and heavier hydrocarbons, which are pumped to the additive recovery column (ARC). The ARC separates butane and heavier components as the bottom stream from propane, which is the ARC overhead stream. The ARC bottoms are cooled and a portion is delivered to the PRC to enhance separation. The remainder of the ARC bottoms and the ARC overhead streams are combined and cooled to form NGL product.

In the 20 MMscfd train, gas will pass through a triethylene glycol dehydrator (DEHY2) before it is reinjected into the ground (via electric-drive compressors) to enhance oil recovery. Emissions from the dehydrator still vent will be routed back to the produced gas separator, with no emissions to the atmosphere. Emissions from DEHY2 in the application are associated with the glycol regenerator heater. A flare (Unit 23) is present to combust gas if it is not reinjected. The new flare may be used in conjunction with the existing flare (Unit 19), though the facility will maintain its current combined permitted limit for both flares.

Liquid bottoms from the PRC consist of propane and heavier hydrocarbons, which are pumped to the additive recovery column (ARC). The ARC separates butane and heavier components as the bottom stream from propane, which is the ARC overhead stream. The ARC bottoms are cooled and a portion is delivered to the PRC to enhance separation. The remainder of the ARC bottoms and the ARC overhead streams are combined and cooled to form NGL product.

Liquids from the produced gas inlet scrubber are transferred to the central tank battery. The central tank battery consists of a skim tank (T-11), an oil sales tank (T-13), an oil surge tank (T-14), a produced water tank (T-15), an overflow tank (T-12), and four (4) gas turbines (units 1-4) with glycol/water heat exchangers. The purpose of the tank battery is to separate the crude oil from the produced water that comes from the production wells. Liquids from the produced gas scrubber are first treated by glycol/water heat exchangers, then separated into crude oil and produced water. The crude oil produced in this separation is stored in an oil surge tank, then transferred to an oil sales tank. An overflow tank may also be utilized if the capacity of the oil sales tank is exceeded. The produced water enters the skim tank, where any residual crude oil in the liquid is skimmed and recycled to the glycol dehydration equipment for further separation. Produced water from the skim tank is stored in T15 before being reinjected into the production wells.

VOC vapors from the central tank battery are recovered by a redundant vapor recovery unit system (Unit 20 or 21). The recovered hydrocarbons are processed for reinjection. During turnarounds, tank vapors may be flared in a temporary flare (Unit 22) if the turbines shut down for any reason. During these periods, the other flare (Unit 19) will not be operating. Additionally, since half of the field is shut in, flaring volumes will be reduced.

Tab 11
Section 11 -Source Determination

Section 11

Source Determination

Source submitting under 20.2.70, 20.2.72, 20.2.73, and 20.2.74 NMAC

Sources applying for a construction permit, PSD permit, or operating permit shall evaluate surrounding and/or associated sources (including those sources directly connected to this source for business reasons) and complete this section. Responses to the following questions shall be consistent with the Air Quality Bureau’s permitting guidance, Single Source Determination Guidance, which may be found on the Applications Page in the Permitting Section of the Air Quality Bureau website.

Typically, buildings, structures, installations, or facilities that have the same SIC code, that are under common ownership or control, and that are contiguous or adjacent constitute a single stationary source for 20.2.70, 20.2.72, 20.2.73, and 20.2.74 NMAC applicability purposes. Submission of your analysis of these factors in support of the responses below is optional, unless requested by NMED.

A. Identify the emission sources evaluated in this section (list and describe):
See Table 2A

B. Apply the 3 criteria for determining a single source:

SIC Code: Surrounding or associated sources belong to the same 2-digit industrial grouping (2-digit SIC code) as this facility, OR surrounding or associated sources that belong to different 2-digit SIC codes are support facilities for this source.

Yes **No**

Common Ownership or Control: Surrounding or associated sources are under common ownership or control as this source.

Yes **No**

Contiguous or Adjacent: Surrounding or associated sources are contiguous or adjacent with this source.

Yes **No**

C. Make a determination:

The source, as described in this application, constitutes the entire source for 20.2.70, 20.2.72, 20.2.73, or 20.2.74 NMAC applicability purposes. If in “A” above you evaluated only the source that is the subject of this application, all “**YES**” boxes should be checked. If in “A” above you evaluated other sources as well, you must check **AT LEAST ONE** of the boxes “**NO**” to conclude that the source, as described in the application, is the entire source for 20.2.70, 20.2.72, 20.2.73, and 20.2.74 NMAC applicability purposes.

The source, as described in this application, **does not** constitute the entire source for 20.2.70, 20.2.72, 20.2.73, or 20.2.74 NMAC applicability purposes (A permit may be issued for a portion of a source). The entire source consists of the following facilities or emissions sources (list and describe):

Tab 12
Section 12 - PSD Applicability Determination for
All Sources

Section 12

Section 12.A

PSD Applicability Determination for All Sources

(Submitting under 20.2.72, 20.2.74 NMAC)

A PSD applicability determination for all sources. For sources applying for a significant permit revision, apply the applicable requirements of 20.2.74.AG and 20.2.74.200 NMAC and to determine whether this facility is a major or minor PSD source, and whether this modification is a major or a minor PSD modification. It may be helpful to refer to the procedures for Determining the Net Emissions Change at a Source as specified by Table A-5 (Page A.45) of the EPA New Source Review Workshop Manual to determine if the revision is subject to PSD review.

A. This facility is:

X a minor PSD source before and after this modification (if so, delete C and D below).

Tab 13

**Section 13 - Determination of State & Federal Air
Quality Regulations**

Section 13

Determination of State & Federal Air Quality Regulations

This section lists each state and federal air quality regulation that may apply to your facility and/or equipment that are stationary sources of regulated air pollutants.

Not all state and federal air quality regulations are included in this list. Go to the Code of Federal Regulations (CFR) or to the Air Quality Bureau's regulation page to see the full set of air quality regulations.

Required Information for Specific Equipment:

For regulations that apply to specific source types, in the 'Justification' column **provide any information needed to determine if the regulation does or does not apply. For example**, to determine if emissions standards at 40 CFR 60, Subpart IIII apply to your three identical stationary engines, we need to know the construction date as defined in that regulation; the manufacturer date; the date of reconstruction or modification, if any; if they are or are not fire pump engines; if they are or are not emergency engines as defined in that regulation; their site ratings; and the cylinder displacement.

Required Information for Regulations that Apply to the Entire Facility:

See instructions in the 'Justification' column for the information that is needed to determine if an 'Entire Facility' type of regulation applies (e.g. 20.2.70 or 20.2.73 NMAC).

Regulatory Citations for Regulations That Do Not, but Could Apply:

If there is a state or federal air quality regulation that does not apply, but you have a piece of equipment in a source category for which a regulation has been promulgated, you must **provide the low level regulatory citation showing why your piece of equipment is not subject to or exempt from the regulation. For example** if you have a stationary internal combustion engine that is not subject to 40 CFR 63, Subpart ZZZZ because it is an existing 2 stroke lean burn stationary RICE with a site rating of more than 500 brake HP located at a major source of HAP emissions, your citation would be 40 CFR 63.6590(b)(3)(i). **We don't want a discussion of every non-applicable regulation, but if it is possible a regulation could apply, explain why it does not. For example**, if your facility is a power plant, you do not need to include a citation to show that 40 CFR 60, Subpart OOO does not apply to your non-existent rock crusher.

Regulatory Citations for Emission Standards:

For each unit that is subject to an emission standard in a source specific regulation, such as 40 CFR 60, Subpart OOO or 40 CFR 63, Subpart HH, include the low level regulatory citation of that emission standard. Emission standards can be numerical emission limits, work practice standards, or other requirements such as maintenance. **Here are examples:** a glycol dehydrator is subject to the general standards at 63.764C(1)(i) through (iii); an engine is subject to 63.6601, Tables 2a and 2b; a crusher is subject to 60.672(b), Table 3 and all transfer points are subject to 60.672(e)(1)

Federally Enforceable Conditions:

All federal regulations are federally enforceable. All Air Quality Bureau State regulations are federally enforceable except for the following: affirmative defense portions at 20.2.7.6.B, 20.2.7.110(B)(15), 20.2.7.11 through 20.2.7.113, 20.2.7.115, and 20.2.7.116; 20.2.37; 20.2.42; 20.2.43; 20.2.62; 20.2.63; 20.2.86; 20.2.89; and 20.2.90 NMAC. Federally enforceable means that EPA can enforce the regulation as well as the Air Quality Bureau and federally enforceable regulations can count toward determining a facility's potential to emit (PTE) for the Title V, PSD, and nonattainment permit regulations.

INCLUDE ANY OTHER INFORMATION NEEDED TO COMPLETE AN APPLICABILITY DETERMINATION OR THAT IS RELEVANT TO YOUR FACILITY'S NOTICE OF INTENT OR PERMIT.

EPA Applicability Determination Index for 40 CFR 60, 61, 63, etc: <http://cfpub.epa.gov/adi/>

<u>STATE REGU- LATIONS CITATION</u>	Title	Applies? Enter Yes or No	Unit(s) or Facility	JUSTIFICATION: (You may delete instructions or statements that do not apply in the justification column to shorten the document.)
20.2.1 NMAC	General Provisions	Yes	Facility	General Provisions apply to Notice of Intent, Construction, and Title V permit applications.
20.2.3 NMAC	Ambient Air Quality Standards NMAAQs		Facility	If subject, this would normally apply to the entire facility. 20.2.3 NMAC is a State Implementation Plan (SIP) approved regulation that limits the maximum allowable concentration of, Sulfur Compounds, Carbon Monoxide and Nitrogen Dioxide. Title V applications, see exemption at 20.2.3.9 NMAC The TSP NM ambient air quality standard was repealed by the EIB effective November 30, 2018.
20.2.7 NMAC	Excess Emissions		Facility	If subject, this would normally apply to the entire facility. If your entire facility or individual pieces of equipment are subject to emissions limits in a permit or numerical emissions standards in a federal or state regulation, this applies. This would not apply to Notices of Intent since these are not permits.
20.2.23 NMAC	Fugitive Dust Control	No for permitted facilities, possible for NOIs	N/A	Sources exempt from 20.2.23 NMAC are activities and facilities subject to a permit issued pursuant to the NM Air Quality Control Act, the Mining Act, or the Surface Mining Act (20.2.23.108.B NMAC).
20.2.33 NMAC	Gas Burning Equipment - Nitrogen Dioxide	No	N/A	None of the equipment has a rating greater than 100 MMBtu/hr.
20.2.34 NMAC	Oil Burning Equipment: NO ₂	No	N/A	This facility has no oil burning equipment.
20.2.35 NMAC	Natural Gas Processing Plant – Sulfur	No	N/A	The facility is not a gas processing plant.
20.2.37 and 20.2.36 NMAC	Petroleum Processing Facilities and Petroleum Refineries	N/A	N/A	These regulations were repealed by the Environmental Improvement Board. If you had equipment subject to 20.2.37 NMAC before the repeal, your combustion emission sources are now subject to 20.2.61 NMAC.
20.2.38 NMAC	Hydrocarbon Storage Facility	Yes	T-11, T-12, T-13, T-14	A redundant VRU system is used to comply with the control requirements of 20.2.38.109.
20.2.39 NMAC	Sulfur Recovery Plant - Sulfur	No	N/A	The facility does not operate a sulfur recovery plant.
20.2.61.109 NMAC	Smoke & Visible Emissions	Yes	19, 22, 23, 6, 24, 16, 17	This regulation that limits opacity to 20% applies to Stationary Combustion Equipment, such as engines, boilers, heaters, and flares unless your equipment is subject to another state regulation that limits particulate matter such as 20.2.19 NMAC (see 20.2.61.109 NMAC).
20.2.70 NMAC	Operating Permits	Yes	Facility	The facility is a major source of criteria pollutants.
20.2.71 NMAC	Operating Permit Fees	Yes	Facility	The facility is a major source of criteria pollutants.
20.2.72 NMAC	Construction Permits	Yes	Facility	This application requests a permit in accordance with 20.2.72.
20.2.73 NMAC	NOI & Emissions Inventory Requirements	Yes	Facility	The site is subject to the emissions inventory requirements of 20.2.73 NMAC.

<u>STATE REGU- LATIONS CITATION</u>	Title	Applies? Enter Yes or No	Unit(s) or Facility	JUSTIFICATION: (You may delete instructions or statements that do not apply in the justification column to shorten the document.)
20.2.74 NMAC	Permits – Prevention of Significant Deterioration (PSD)	No	N/A	The facility is not a major PSD site.
20.2.75 NMAC	Construction Permit Fees	Yes	Facility	A permit fee is included with this application.
20.2.77 NMAC	New Source Performance	Yes	Facility	See regulatory discussion in Federal Regulations Citation section.
20.2.78 NMAC	Emission Standards for HAPS	No	N/A	The facility does not fit into any of the source categories.
20.2.79 NMAC	Permits – Nonattainment Areas	No	N/A	The facility is not located in a nonattainment area.
20.2.80 NMAC	Stack Heights	No	N/A	There are no stacks to which this regulation would apply.
20.2.82 NMAC	MACT Standards for source categories of HAPS	Yes	16-17, DEHY1 DEHY2	See regulatory discussion in Federal Regulations Citation section.

<u>FEDERAL REGU- LATIONS CITATION</u>	Title	Applies? Enter Yes or No	Unit(s) or Facility	JUSTIFICATION:
40 CFR 50	NAAQS	Yes	Facility	Compliance was demonstrated via modeling.
NSPS 40 CFR 60, Subpart A	General Provisions	Yes	Units subject to 40 CFR 60	Applies if any other Subpart in 40 CFR 60 applies.
NSPS 40 CFR60.40a, Subpart Da	Subpart Da, Performance Standards for Electric Utility Steam Generating Units	No	N/A	The facility does not operate any electric utility steam generating units.
NSPS 40 CFR60.40b Subpart Db	Electric Utility Steam Generating Units	No	N/A	The facility does not operate any electric utility steam generating units.
40 CFR 60.40c, Subpart Dc	Standards of Performance for Small Industrial- Commercial- Institutional Steam Generating Units	Yes	7	The heaters have an input rating greater than 10 MMBtu/hr and are subject per §60.40c(a). Since the units burn only natural gas, there are no applicable control, monitoring, or reporting requirements. Fuel use records are required per §60.48c(g).

FEDERAL REGU- LATIONS CITATION	Title	Applies? Enter Yes or No	Unit(s) or Facility	JUSTIFICATION:
NSPS 40 CFR 60, Subpart Ka	Tanks After May 18, 1978, and Prior to July 23, 1984	No	N/A	The old tanks are being removed.
NSPS 40 CFR 60, Subpart Kb	Tanks Commenced After July 23, 1984	No	N/A	The hydrocarbons are stored prior to custody transfer.
NSPS 40 CFR 60.330 Subpart GG	Stationary Gas Turbines	Yes	1-4	Units 1-4 have a heat input > 10 MMBtu/hr and were installed after October 3, 1977 and are therefore subject to the SO2 standards. Unit 4 was constructed prior to October 3, 1982 and is exempt from the NOx standard.
NSPS 40 CFR 60, Subpart KKK	Leaks of VOC from Onshore Gas Plants	Yes	Equip. in VOC or wet gas svc.	Certain portions of the plant are subject to NSPS KKK. The new portion of the plant does not fractionate NGLs and is not subject to Subpart KKK.
NSPS 40 CFR Part 60 Subpart LLL	Standards of Performance for Onshore Natural Gas Processing: SO2 Emissions	No	N/A	The facility does not operate a sweetening unit.
NSPS 40 CFR Part 60 Subpart OOOO	O&G sites after August 23, 2011 and before September 18, 2015	No	N/A	The existing portion of the plant pre-dates Subpart OOOO. All new pneumatics are low bleed.
NSPS 40 CFR Part 60 Subpart OOOOa	O&G Sites After September 18, 2015	No	N/A	New storage tank emissions are limited to less than 6 tpy. No new wells have been brought into the site that could impact NSPS OOOOa applicability for fugitive components; therefore, no modification has occurred per 40 CFR 60.5365a(i)(3).
NSPS 40 CFR 60 Subpart IIII	Standards of performance for Stationary Compression Ignition Internal Combustion Engines	No	N/A	The site does not operate any compression ignition engines.
NSPS 40 CFR Part 60 Subpart JJJJ	Standards of Performance for Stationary Spark Ignition Internal Combustion Engines	No	N/A	All of the engines were manufactured prior to the applicability date of the rule.
NSPS 40 CFR 60 Subpart TTTT	Standards of Performance for Greenhouse Gas Emissions for Electric Generating Units	No	N/A	The facility does not operate any affected sources.
NSPS 40 CFR 60 Subpart UUUU	Emissions Guidelines for Greenhouse Gas Emissions and Compliance Times for Electric Utility Generating Units	No	N/A	The facility does not operate any affected sources.

FEDERAL REGU- LATIONS CITATION	Title	Applies? Enter Yes or No	Unit(s) or Facility	JUSTIFICATION:
NSPS 40 CFR 60, Subparts WWW, XXX, Cc, and Cf	Standards of performance for Municipal Solid Waste (MSW) Landfills	No	N/A	The facility does not operate any affected sources.
NESHAP 40 CFR 61 Subpart A	General Provisions	See Below	See Below	See regulatory discussion below.
NESHAP 40 CFR 61 Subpart E	National Emission Standards for Mercury	No	N/A	The facility does not operate any affected sources.
NESHAP 40 CFR 61 Subpart V	National Emission Standards for Equipment Leaks (Fugitive Emission Sources)	No	N/A	The facility does not operate any affected sources.
MACT 40 CFR 63, Subpart A	General Provisions	Yes	Units Subject to 40 CFR 63	Applies if any other Subpart in 40 CFR 63 applies.
MACT 40 CFR 63.760 Subpart HH	Oil and Natural Gas Production Facilities	Yes	DEHY1, DEHY2	Both dehydrators are area sources of HAP subject to Subpart HH. Since benzene emissions are restricted to less than 1 tpy per a federally-enforceable permit; therefore, the unit is exempt from any requirements per §63.764(e)(1)(ii).
MACT 40 CFR 63 Subpart HHH		No	N/A	The facility does not operate any affected sources.
MACT 40 CFR 63 Subpart DDDD	National Emission Standards for Hazardous Air Pollutants for Major Industrial, Commercial, and Institutional Boilers & Process Heaters	No	N/A	The facility does not operate any affected sources.
MACT 40 CFR 63 Subpart UUUU	National Emission Standards for Hazardous Air Pollutants Coal & Oil Fire Electric Utility Steam Generating Unit	No	N/A	The facility does not operate any affected sources.
MACT 40 CFR 63 Subpart ZZZZ	RICE MACT	Yes	Units 16, 17	The engines are subject to Subpart ZZZZ for remote 4SRB engines > 500 hp located at an area source of HAP emissions.

FEDERAL REGU- LATIONS CITATION	Title	Applies? Enter Yes or No	Unit(s) or Facility	JUSTIFICATION:
40 CFR 64	Compliance Assurance Monitoring	Yes	Units 16, 17, 19	A CAM plan is incorporated into the Title V permit.
40 CFR 68	Chemical Accident Prevention	No	N/A	The facility does not store any chemicals above threshold quantities.
Title IV – Acid Rain 40 CFR 72	Acid Rain	No	N/A	The facility does not have any units subject to the Acid Rain regulations.
Title IV – Acid Rain 40 CFR 73	Sulfur Dioxide Allowance Emissions	No	N/A	The facility does not have any units subject to the Acid Rain regulations.
Title IV-Acid Rain 40 CFR 75	Continuous Emissions Monitoring	No	N/A	The facility does not have any units subject to the Acid Rain regulations.
Title IV – Acid Rain 40 CFR 76	Acid Rain Nitrogen Oxides Emission Reduction Program	No	N/A	The facility does not have any units subject to the Acid Rain regulations.
Title VI – 40 CFR 82	Protection of Stratospheric Ozone	No	N/A	The facility does not service, maintain, or repair equipment containing refrigerants.

Tab 14

Section 14 - Operational Plan to Mitigate Emissions

Section 14

Operational Plan to Mitigate Emissions

(Submitting under 20.2.70, 20.2.72, 20.2.74 NMAC)

- Title V Sources** (20.2.70 NMAC): By checking this box and certifying this application the permittee certifies that it has developed an **Operational Plan to Mitigate Emissions During Startups, Shutdowns, and Emergencies** defining the measures to be taken to mitigate source emissions during startups, shutdowns, and emergencies as required by 20.2.70.300.D.5(f) and (g) NMAC. This plan shall be kept on site to be made available to the Department upon request. This plan should not be submitted with this application.
- NSR** (20.2.72 NMAC), **PSD** (20.2.74 NMAC) & **Nonattainment** (20.2.79 NMAC) **Sources**: By checking this box and certifying this application the permittee certifies that it has developed an **Operational Plan to Mitigate Source Emissions During Malfunction, Startup, or Shutdown** defining the measures to be taken to mitigate source emissions during malfunction, startup, or shutdown as required by 20.2.72.203.A.5 NMAC. This plan shall be kept on site to be made available to the Department upon request. This plan should not be submitted with this application.
- Title V** (20.2.70 NMAC), **NSR** (20.2.72 NMAC), **PSD** (20.2.74 NMAC) & **Nonattainment** (20.2.79 NMAC) **Sources**: By checking this box and certifying this application the permittee certifies that it has established and implemented a Plan to Minimize Emissions During Routine or Predictable Startup, Shutdown, and Scheduled Maintenance through work practice standards and good air pollution control practices as required by 20.2.7.14.A and B NMAC. This plan shall be kept on site or at the nearest field office to be made available to the Department upon request. This plan should not be submitted with this application.
-

A copy of the actual startup and shutdown guidelines for the facility is available upon request. Startup and shutdown procedures are performed according to these guidelines.

Equipment at the plant is equipped with various safety devices that aid in preventing excess emissions in the event of an emergency. The following operational conditions will trigger emergency the shutdown system. Refer to the written guidelines for further discussion of these conditions.

- Power failure
- Activation of combustible gas alarms
- Loss of instrument air
- Low suction pressure on the reinjection compressors
- High levels in the produced gas separator and propane recovery reflux drum

In the event of a malfunction or other event that may potentially increase emissions such as a failure of a control device, ConocoPhillips complies with the requirements of 20.2.7 NMAC, including taking appropriate steps to minimize emissions.

Tab 15
Section 15 - Alternative Operating Scenarios

Section 15

Alternative Operating Scenarios

(Submitting under 20.2.70, 20.2.72, 20.2.74 NMAC)

Alternative Operating Scenarios: Provide all information required by the department to define alternative operating scenarios. This includes process, material and product changes; facility emissions information; air pollution control equipment requirements; any applicable requirements; monitoring, recordkeeping, and reporting requirements; and compliance certification requirements. Please ensure applicable Tables in this application are clearly marked to show alternative operating scenario.

Construction Scenarios: When a permit is modified authorizing new construction to an existing facility, NMED includes a condition to clearly address which permit condition(s) (from the previous permit and the new permit) govern during the interval between the date of issuance of the modification permit and the completion of construction of the modification(s). There are many possible variables that need to be addressed such as: Is simultaneous operation of the old and new units permitted and, if so for example, for how long and under what restraints? In general, these types of requirements will be addressed in Section A100 of the permit, but additional requirements may be added elsewhere. Look in A100 of our NSR and/or TV permit template for sample language dealing with these requirements. Find these permit templates at: https://www.env.nm.gov/aqb/permit/aqb_pol.html. Compliance with standards must be maintained during construction, which should not usually be a problem unless simultaneous operation of old and new equipment is requested.

In this section, under the bolded title “Construction Scenarios”, specify any information necessary to write these conditions, such as: conservative-realistic estimated time for completion of construction of the various units, whether simultaneous operation of old and new units is being requested (and, if so, modeled), whether the old units will be removed or decommissioned, any PSD ramifications, any temporary limits requested during phased construction, whether any increase in emissions is being requested as SSM emissions or will instead be handled as a separate Construction Scenario (with corresponding emission limits and conditions, etc).

ConocoPhillips has an enforceable condition that only one flare can be operated at one time for the alternate operating scenario between Process Flares Units 19/23 and the temporary flare. The temporary flare will be rented during planned maintenance while the permanent flare is shutdown. Emissions do not increase while using the temporary flare as flaring volumes decrease during this time.

Tab 16
Section 16 - Air Dispersion Modeling

Section 16

Air Dispersion Modeling

- 1) Minor Source Construction (20.2.72 NMAC) and Prevention of Significant Deterioration (PSD) (20.2.74 NMAC) ambient impact analysis (modeling): Provide an ambient impact analysis as required at 20.2.72.203.A(4) and/or 20.2.74.303 NMAC and as outlined in the Air Quality Bureau’s Dispersion Modeling Guidelines found on the Planning Section’s modeling website. If air dispersion modeling has been waived for one or more pollutants, attach the AQB Modeling Section modeling waiver approval documentation.
- 2) SSM Modeling: Applicants must conduct dispersion modeling for the total short term emissions during routine or predictable startup, shutdown, or maintenance (SSM) using realistic worst case scenarios following guidance from the Air Quality Bureau’s dispersion modeling section. Refer to "Guidance for Submittal of Startup, Shutdown, Maintenance Emissions in Permit Applications (http://www.env.nm.gov/aqb/permit/app_form.html) for more detailed instructions on SSM emissions modeling requirements.
- 3) Title V (20.2.70 NMAC) ambient impact analysis: Title V applications must specify the construction permit and/or Title V Permit number(s) for which air quality dispersion modeling was last approved. Facilities that have only a Title V permit, such as landfills and air curtain incinerators, are subject to the same modeling required for preconstruction permits required by 20.2.72 and 20.2.74 NMAC.

What is the purpose of this application?	Enter an X for each purpose that applies
New PSD major source or PSD major modification (20.2.74 NMAC). See #1 above.	
New Minor Source or significant permit revision under 20.2.72 NMAC (20.2.72.219.D NMAC). See #1 above. Note: Neither modeling nor a modeling waiver is required for VOC emissions.	
Reporting existing pollutants that were not previously reported.	
Reporting existing pollutants where the ambient impact is being addressed for the first time.	
Title V application (new, renewal, significant, or minor modification. 20.2.70 NMAC). See #3 above.	X
Relocation (20.2.72.202.B.4 or 72.202.D.3.c NMAC)	
Minor Source Technical Permit Revision 20.2.72.219.B.1.d.vi NMAC for like-kind unit replacements.	
Other: i.e. SSM modeling. See #2 above.	
This application does not require modeling since this is a No Permit Required (NPR) application.	
This application does not require modeling since this is a Notice of Intent (NOI) application (20.2.73 NMAC).	
This application does not require modeling according to 20.2.70.7.E(11), 20.2.72.203.A(4), 20.2.74.303, 20.2.79.109.D NMAC and in accordance with the Air Quality Bureau’s Modeling Guidelines.	

Check each box that applies:

- See attached, approved modeling **waiver for all** pollutants from the facility.
- See attached, approved modeling **waiver for some** pollutants from the facility.
- Attached in Universal Application Form 4 (UA4) is a **modeling report for all** pollutants from the facility.
- Attached in UA4 is a **modeling report for some** pollutants from the facility.
- No modeling is required.

Tab 17
Section 17 - Compliance Test History

Section 17

Compliance Test History

(Submitting under 20.2.70, 20.2.72, 20.2.74 NMAC)

To show compliance with existing NSR permits conditions, you must submit a compliance test history. The table below provides an example.

The internal combustion engines are tested quarterly, with all engines demonstrating compliance with emission limitations.

Unit No.	Test Description	Test Date
16	Permit Required Quarterly Monitoring	5/19/20
17	Permit Required Quarterly Monitoring	5/19/20

Tab 18
Section 18 - Addendum for Streamline Applications
(Not Applicable)

Section 18

Addendum for Streamline Applications

Do not print this section unless this is a streamline application.

Streamline Applications do not require a complete application. Submit Sections 1-A, 1-B, 1-D, 1-F, 1-G, 2-A, 2-C thru L, Sections 3 thru 8, Section 13, Section 18, Section 22, and Section 23 (Certification). Other sections may be required at the discretion of the Department. 20.2.72.202 NMAC Exemptions do not apply to Streamline sources. 20.2.72.219 NMAC revisions and modifications do not apply to Streamline sources, thus 20.2.72.219 type actions require a complete new application submittal. Please do not print sections of a streamline application that are not required.

This is not a Streamline permit application.

Tab 19
Section 19 - Requirements for Title V Program

Section 19

Requirements for Title V Program

Do not print this section unless this is a Title V application.

Who Must Use this Attachment:

- * Any major source as defined in 20.2.70 NMAC.
 - * Any source, including an area source, subject to a standard or other requirement promulgated under Section 111 - Standards of Performance for New Stationary Sources, or Section 112 Hazardous Air Pollutants, of the 1990 federal Clean Air Act ("federal Act"). Non-major sources subject to Sections 111 or 112 of the federal Act are exempt from the obligation to obtain a 20.2.70 NMAC operating permit until such time that the EPA Administrator completes rulemakings that require such sources to obtain operating permits. In addition, sources that would be required to obtain an operating permit solely because they are subject to regulations or requirements under Section 112(r) of the federal Act are exempt from the requirement to obtain an Operating Permit.
 - * Any Acid Rain source as defined under title IV of the federal Act. The Acid Rain program has additional forms. See <http://www.env.nm.gov/aqb/index.html>. Sources that are subject to both the Title V and Acid Rain regulations are encouraged to submit both applications simultaneously.
 - * Any source in a source category designated by the EPA Administrator ("Administrator"), in whole or in part, by regulation, after notice and comment.
-

19.1 - 40 CFR 64, Compliance Assurance Monitoring (CAM) (20.2.70.300.D.10.e NMAC)

Any source subject to 40CFR, Part 64 (Compliance Assurance Monitoring) must submit all the information required by section 64.7 with the operating permit application. The applicant must prepare a separate section of the application package for this purpose; if the information is already listed elsewhere in the application package, make reference to that location. Facilities not subject to Part 64 are invited to submit periodic monitoring protocols with the application to help the AQB to comply with 20.2.70 NMAC. Sources subject to 40 CFR Part 64, must submit a statement indicating your source's compliance status with any enhanced monitoring and compliance certification requirements of the federal Act.

CAM Plan is attached to the existing Title V Permit. ConocoPhillips Company complies with the monitoring and recordkeeping requirements in the CAM Plan. No modifications have been made that would affect the CAM Plan.

19.2 - Compliance Status (20.2.70.300.D.10.a & 10.b NMAC)

Describe the facility's compliance status with each applicable requirement at the time this permit application is submitted. This statement should include descriptions of or references to all methods used for determining compliance. This statement should include descriptions of monitoring, recordkeeping and reporting requirements and test methods used to determine compliance with all applicable requirements. Refer to Section 2, Tables 2-N and 2-O of the Application Form as necessary. (20.2.70.300.D.11 NMAC) For facilities with existing Title V permits, refer to most recent Compliance Certification for existing requirements. Address new requirements such as CAM, here, including steps being taken to achieve compliance.

The annual compliance certification was submitted on December 22, 2014.

19.3 - Continued Compliance (20.2.70.300.D.10.c NMAC)

Provide a statement that your facility will continue to be in compliance with requirements for which it is in compliance at the time of permit application. This statement must also include a commitment to comply with other applicable requirements as they come into effect during the permit term. This compliance must occur in a timely manner or be consistent with such schedule expressly required by the applicable requirement.

Based on information and belief formed after reasonable inquiry, ConocoPhillips Company states the facility is in compliance with applicable requirements and will continue to remain in compliance with applicable requirements. ConocoPhillips Company is committed to comply with applicable requirements as they come into effect during the permit term.

19.4 - Schedule for Submission of Compliance (20.2.70.300.D.10.d NMAC)

You must provide a proposed schedule for submission to the department of compliance certifications during the permit term. This certification must be submitted annually unless the applicable requirement or the department specifies a more frequent period. A sample form for these certifications will be attached to the permit.

ConocoPhillips Company will submit Compliance Certifications every 12 months no later than 30 days after December 1 of each year.

19.5 - Stratospheric Ozone and Climate Protection

In addition to completing the four (4) questions below, you must submit a statement indicating your source's compliance status with requirements of Title VI, Section 608 (National Recycling and Emissions Reduction Program) and Section 609 (Servicing of Motor Vehicle Air Conditioners).

-
1. Does your facility have any air conditioners or refrigeration equipment that uses CFCs, HCFCs or other ozone-depleting substances? **Yes** **No**
 2. Does any air conditioner(s) or any piece(s) of refrigeration equipment contain a refrigeration charge greater than 50 lbs? **Yes** **No**
(If the answer is yes, describe the type of equipment and how many units are at the facility.)
 3. Do your facility personnel maintain, service, repair, or dispose of any motor vehicle air conditioners (MVACs) or appliances ("appliance" and "MVAC" as defined at 82. 152)? **Yes** **No**
 4. Cite and describe which Title VI requirements are applicable to your facility (i.e. 40 CFR Part 82, Subpart A through G.) N/A
-

19.6 - Compliance Plan and Schedule

Applications for sources, which are not in compliance with all applicable requirements at the time the permit application is submitted to the department, must include a proposed compliance plan as part of the permit application package. This plan shall include the information requested below:

A. Description of Compliance Status: (20.2.70.300.D.11.a NMAC)

A narrative description of your facility's compliance status with respect to all applicable requirements (as defined in 20.2.70 NMAC) at the time this permit application is submitted to the department.

B. Compliance plan: (20.2.70.300.D.11.B NMAC)

A narrative description of the means by which your facility will achieve compliance with applicable requirements with which it is not in compliance at the time you submit your permit application package.

C. Compliance schedule: (20.2.70.300D.11.c NMAC)

A schedule of remedial measures that you plan to take, including an enforceable sequence of actions with milestones, which will lead to compliance with all applicable requirements for your source. This schedule of compliance must be at least as stringent as that contained in any consent decree or administrative order to which your source is subject. The obligations of any consent decree or administrative order are not in any way diminished by the schedule of compliance.

D. Schedule of Certified Progress Reports: (20.2.70.300.D.11.d NMAC)

A proposed schedule for submission to the department of certified progress reports must also be included in the compliance schedule. The proposed schedule must call for these reports to be submitted at least every six (6) months.

E. Acid Rain Sources: (20.2.70.300.D.11.e NMAC)

If your source is an acid rain source as defined by EPA, the following applies to you. For the portion of your acid rain source subject to the acid rain provisions of title IV of the federal Act, the compliance plan must also include any additional requirements under the acid rain provisions of title IV of the federal Act. Some requirements of title IV regarding the schedule and methods the source will use to achieve compliance with the acid rain emissions limitations may supersede the requirements of title V and 20.2.70 NMAC. You will need to consult with the Air Quality Bureau permitting staff concerning how to properly meet this requirement.

NOTE: The Acid Rain program has additional forms. See <http://www.env.nm.gov/aqb/index.html>. Sources that are subject to both the Title V and Acid Rain regulations are **encouraged** to submit both applications **simultaneously**.

A compliance plan is not required as the facility is in compliance with applicable requirements.

19.7 - 112(r) Risk Management Plan (RMP)

Any major sources subject to section 112(r) of the Clean Air Act must list all substances that cause the source to be subject to section 112(r) in the application. The permittee must state when the RMP was submitted to and approved by EPA.

The facility submitted the initial RMP in accordance with 40 CFR 68.

19.8 - Distance to Other States, Bernalillo, Indian Tribes and Pueblos

Will the property on which the facility is proposed to be constructed or operated be closer than 80 km (50 miles) from other states, local pollution control programs, and Indian tribes and pueblos (20.2.70.402.A.2 and 20.2.70.7.B NMAC)?

(If the answer is yes, state which apply and provide the distances.)

The facility is 24.7 miles from Texas.

19.9 - Responsible Official

The Responsible Official is listed in the UA1 form.

Tab 20
Section 20 - Other Relevant Information

Section 20

Other Relevant Information

Other relevant information. Use this attachment to clarify any part in the application that you think needs explaining. Reference the section, table, column, and/or field. Include any additional text, tables, calculations or clarifying information.

Additionally, the applicant may propose specific permit language for AQB consideration. In the case of a revision to an existing permit, the applicant should provide the old language and the new language in track changes format to highlight the proposed changes. If proposing language for a new facility or language for a new unit, submit the proposed operating condition(s), along with the associated monitoring, recordkeeping, and reporting conditions. In either case, please limit the proposed language to the affected portion of the permit.

No other relevant information is provided.

Tab 21
Section 21 - Addendum for Landfill Applications
(Not Applicable)

Section 21

Addendum for Landfill Applications

Do not print this section unless this is a landfill application.

Landfill Applications are not required to complete Sections 1-C Input Capacity and Production Rate, 1-E Operating Schedule, 17 Compliance Test History, and 18 Streamline Applications. Section 12 – PSD Applicability is required only for Landfills with Gas Collection and Control Systems and/or landfills with other non-fugitive stationary sources of air emissions such as engines, turbines, boilers, heaters. All other Sections of the Universal Application Form are required.

EPA Background Information for MSW Landfill Air Quality Regulations:

<https://www3.epa.gov/airtoxics/landfill/landflpg.html>

NM Solid Waste Bureau Website: <https://www.env.nm.gov/swb/>

This is not a landfill.

Tab 22
Section 22 - Certification

Section 22: Certification

Company Name: _____

I, _____, hereby certify that the information and data submitted in this application are true and as accurate as possible, to the best of my knowledge and professional expertise and experience.

Signed this ____ day of _____, _____, upon my oath or affirmation, before a notary of the State of

_____.

*Signature

Date

Printed Name

Title

Scribed and sworn before me on this ____ day of _____, _____.

My authorization as a notary of the State of _____ expires on the

_____ day of _____, _____.

Notary's Signature

Date

Notary's Printed Name

*For Title V applications, the signature must be of the Responsible Official as defined in 20.2.70.7.AE NMAC.