

Figure M2-1
Repository Horizon

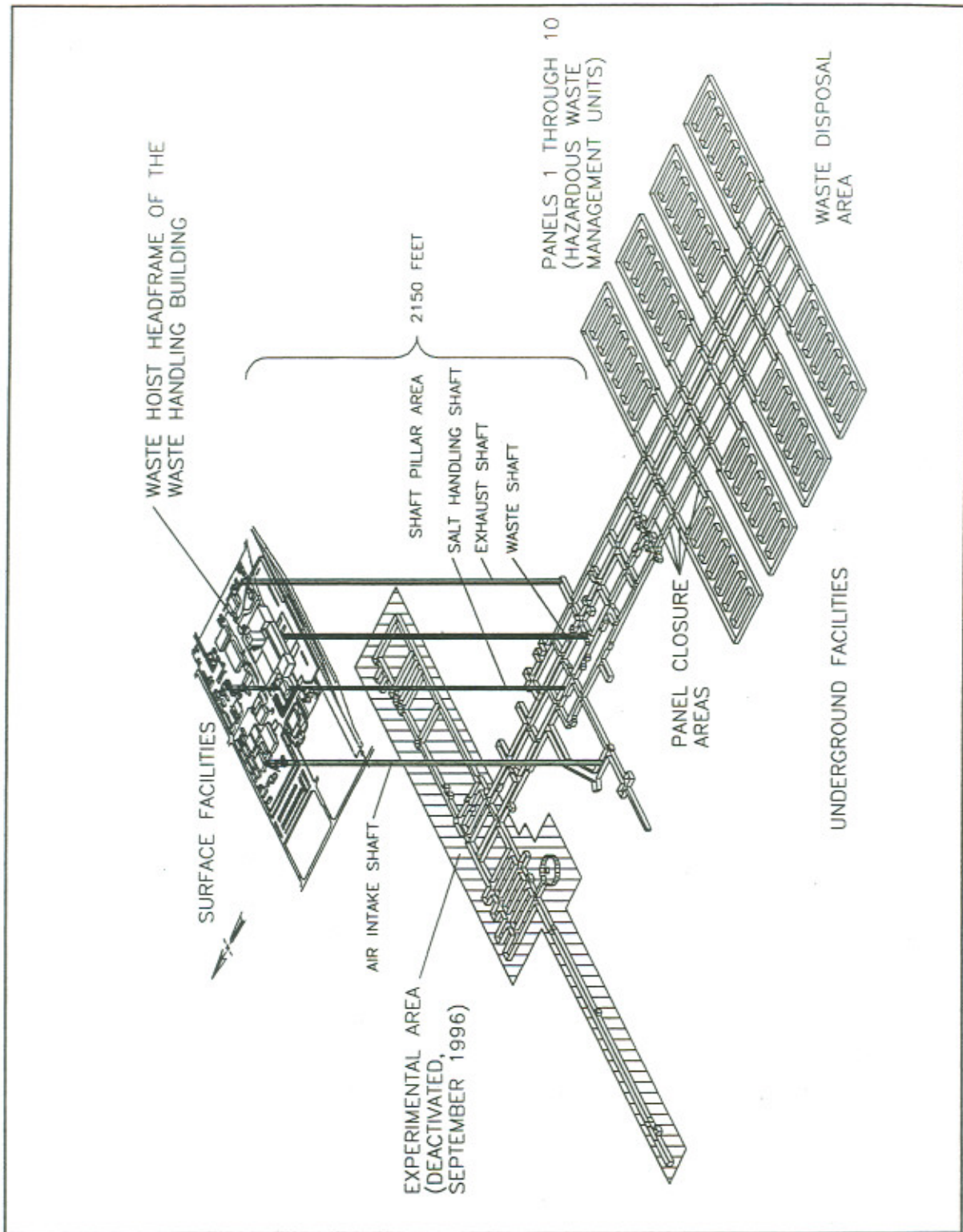

Figure M2-2
Spatial View of the Miscellaneous Unit and Waste Handling Facility

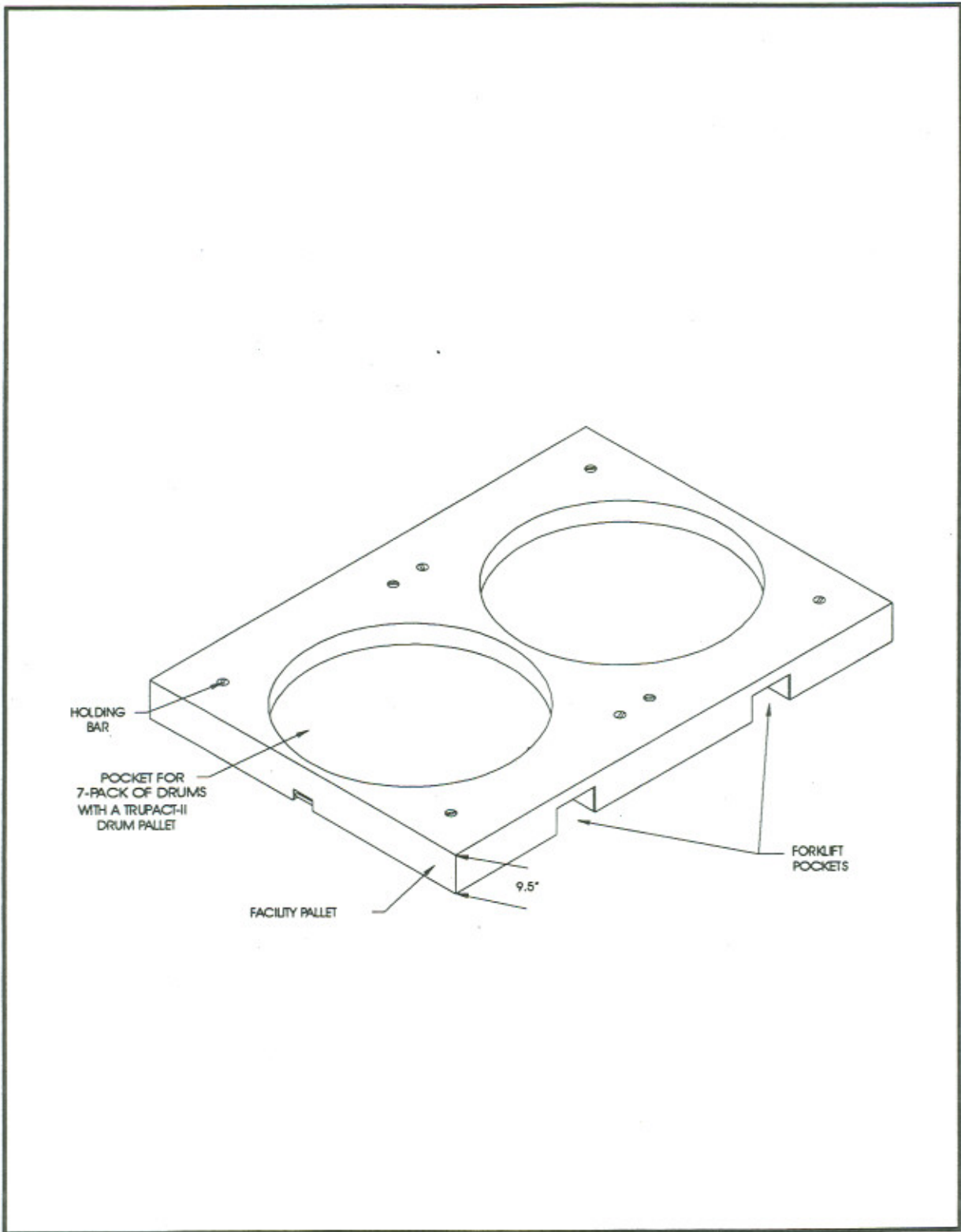

Figure M2-3
Facility Pallet for Seven-Pack of Drums

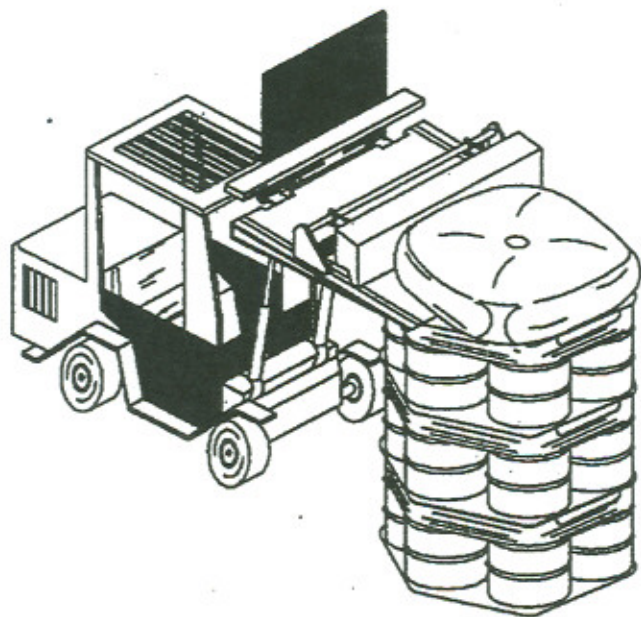
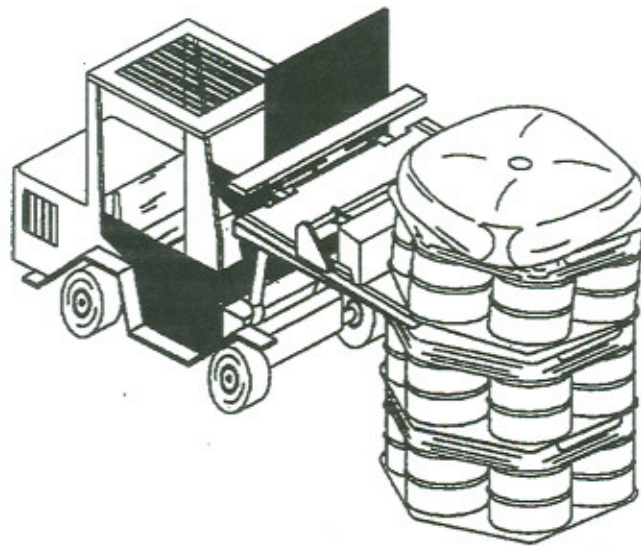

Figure M2-5
Typical Backfill Sacks Emplaced on Drum Stacks on Drum Stacks

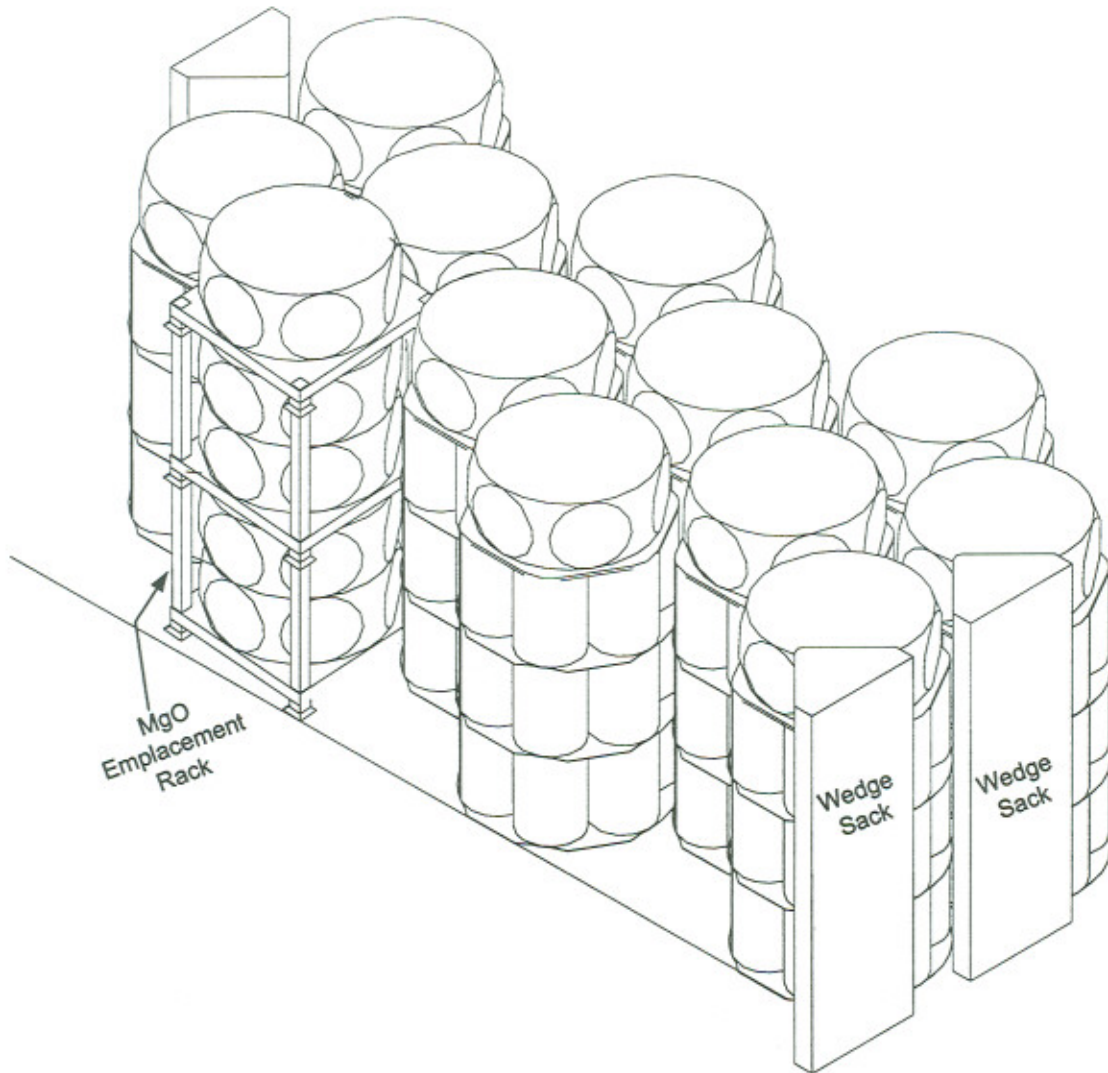

Figure M2-5a
Potential MgO Emplacement Configurations

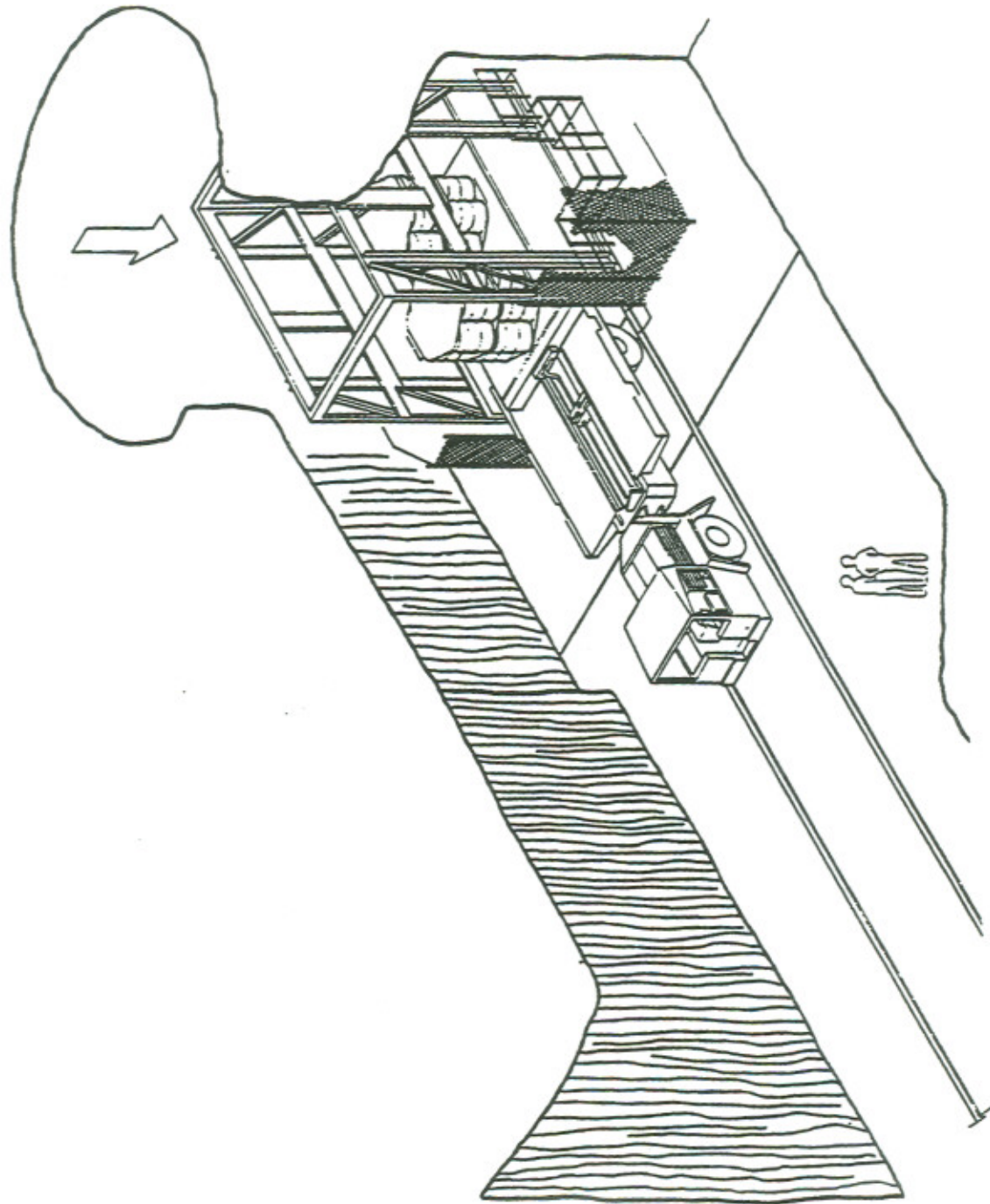

Figure M2-6
Waste Transfer Cage to Transporter

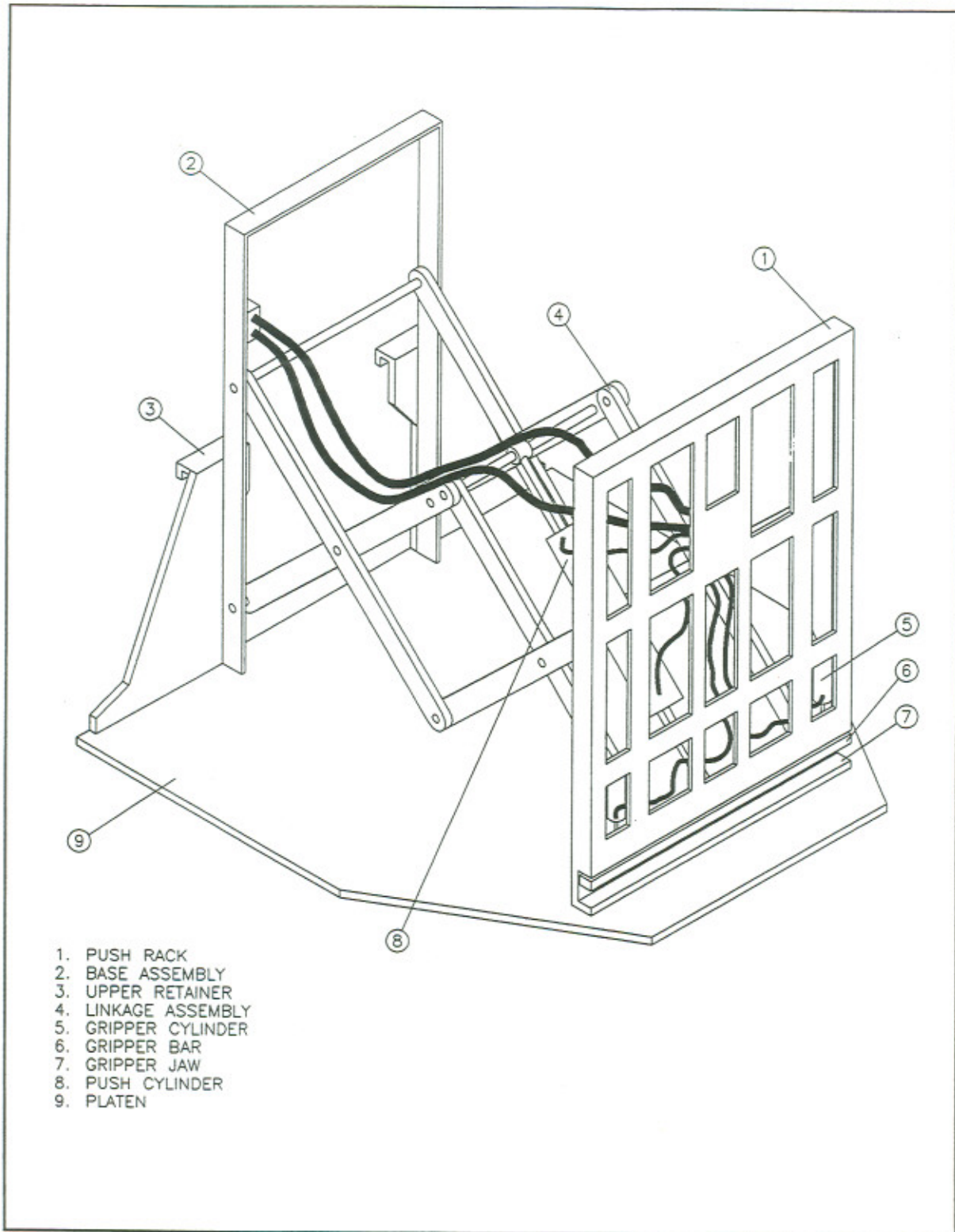

Figure M2-7
Push-Pull Attachment to Forklift to Allow Handling of Waste Containers

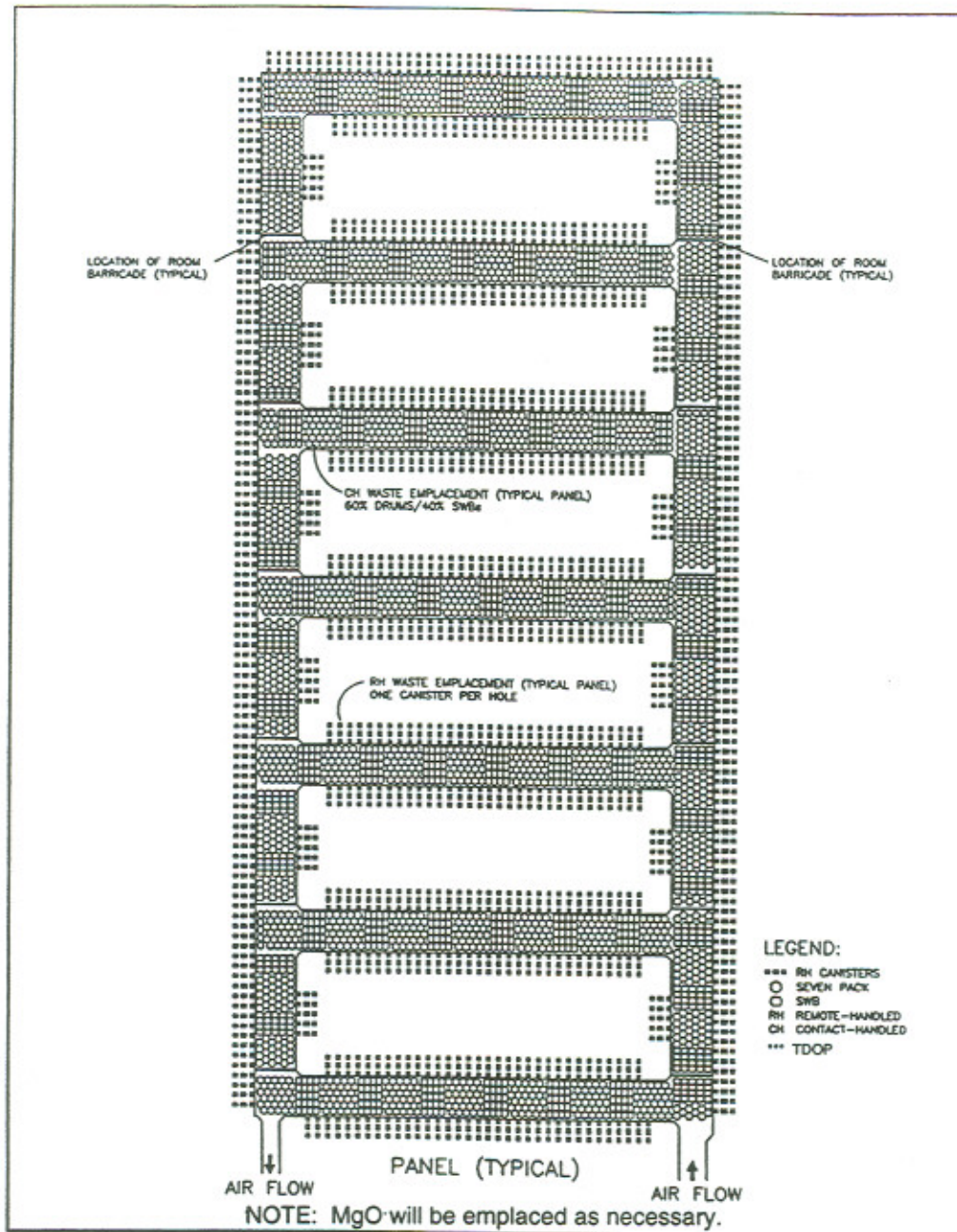

Figure M2-8
Typical RH and CH Transuranic Mixed Waste Container Disposal Configuration

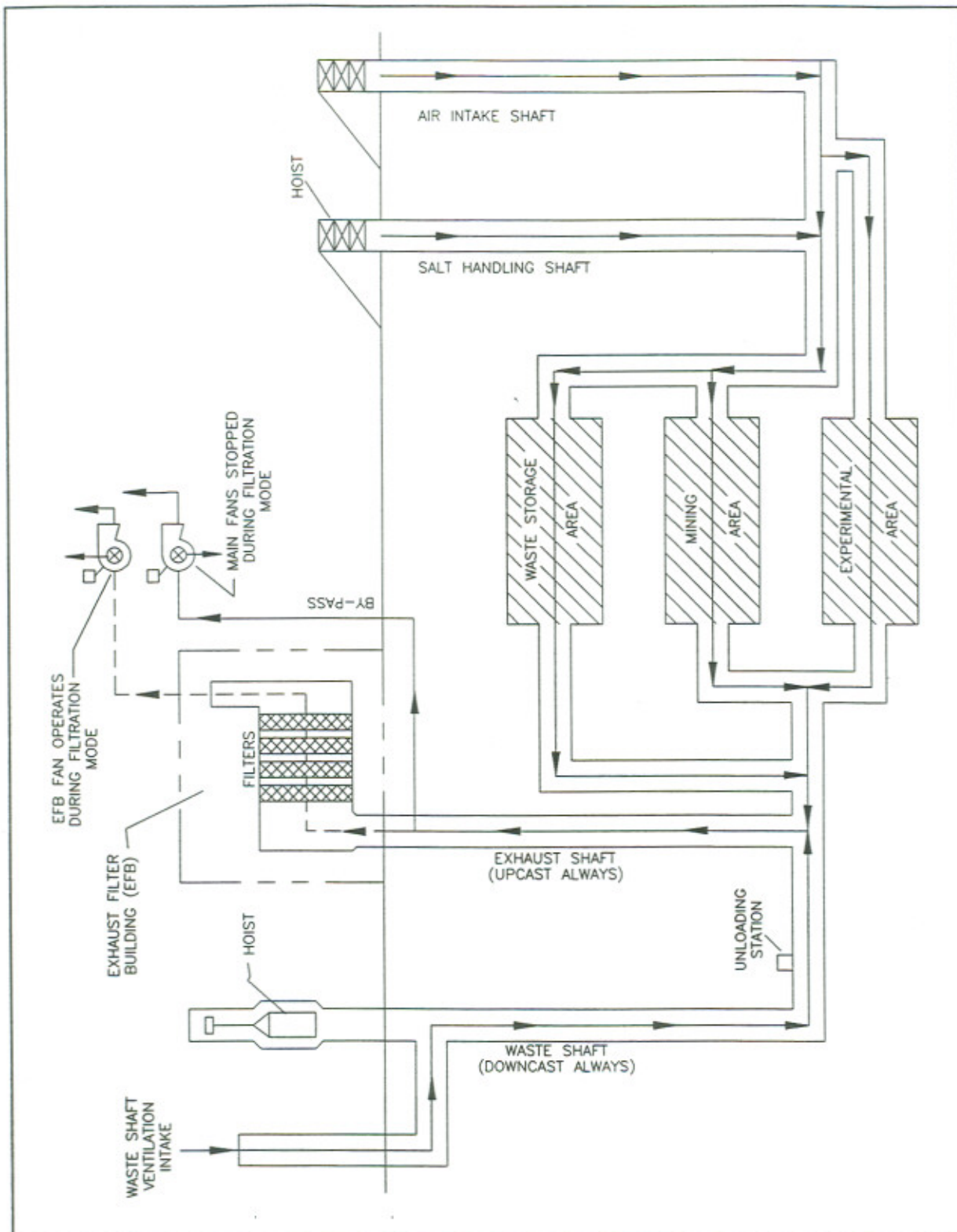

Figure M2-9
Underground Ventilation System Airflow

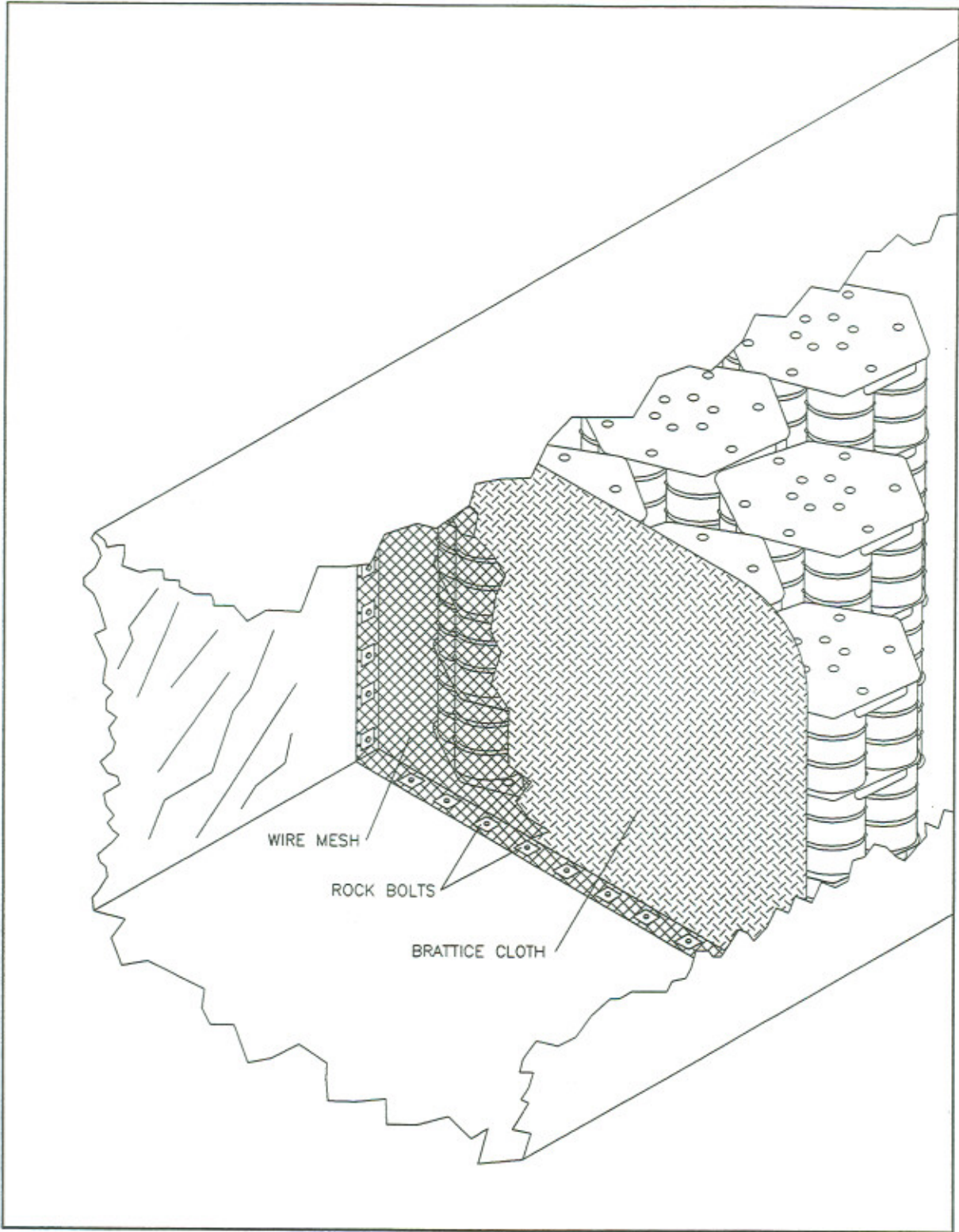

Figure M2-11
Typical Room Barricade

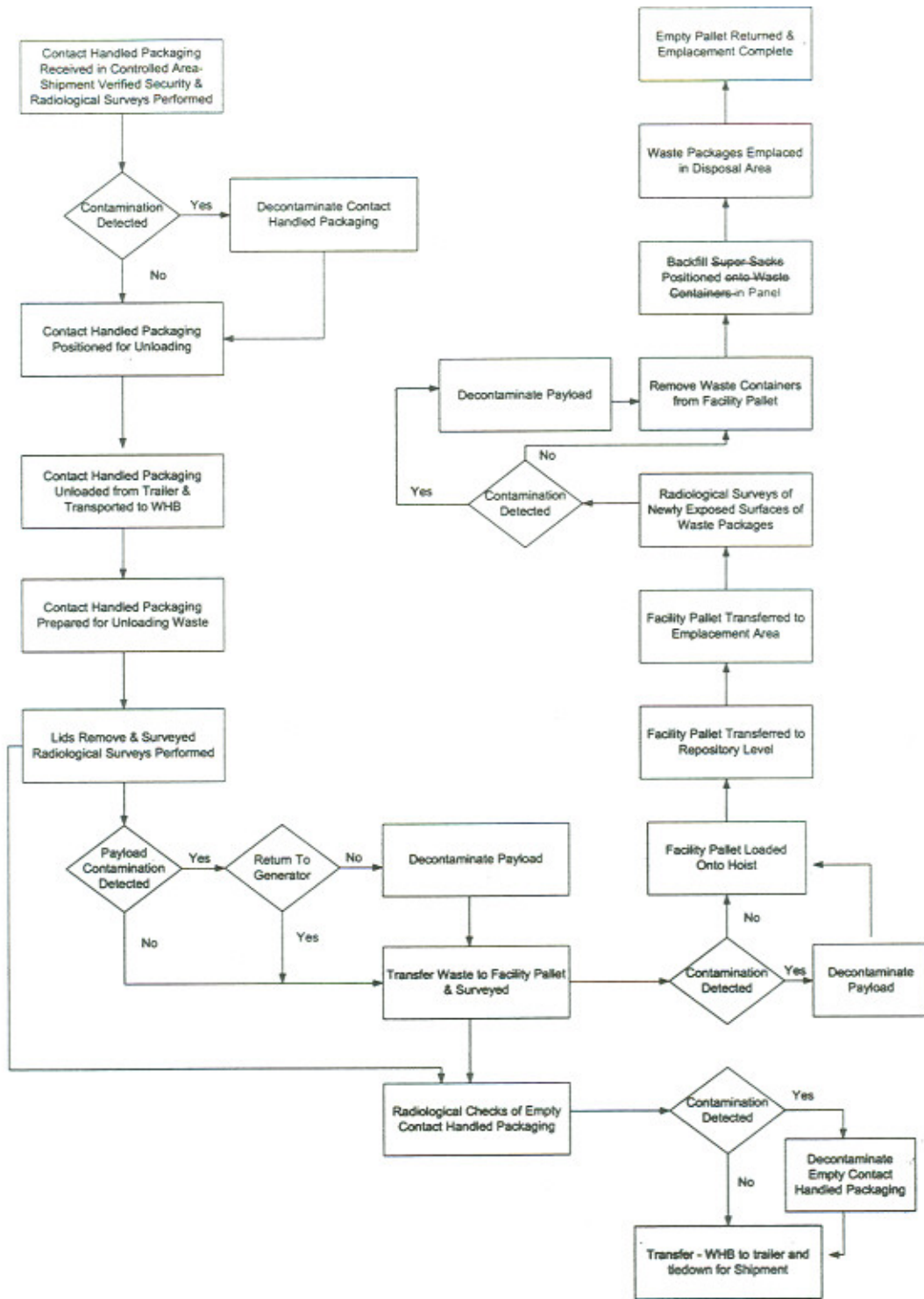

Figure M2-12
 WIPP Facility Surface and Underground CH Transuranic Mixed Waste Process Flow Diagram

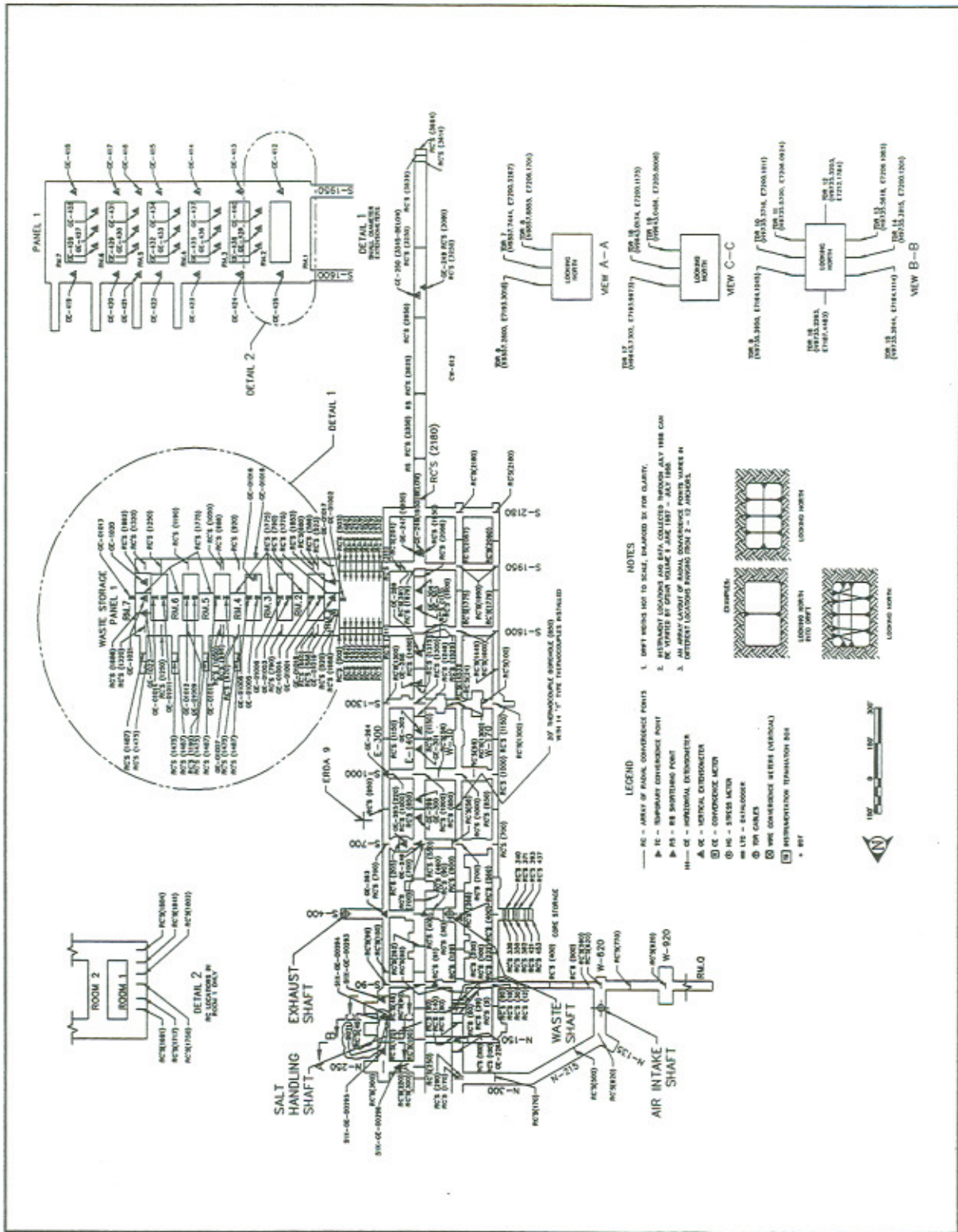

Figure M2-13
 Layout and Instrumentation - As of 1/96

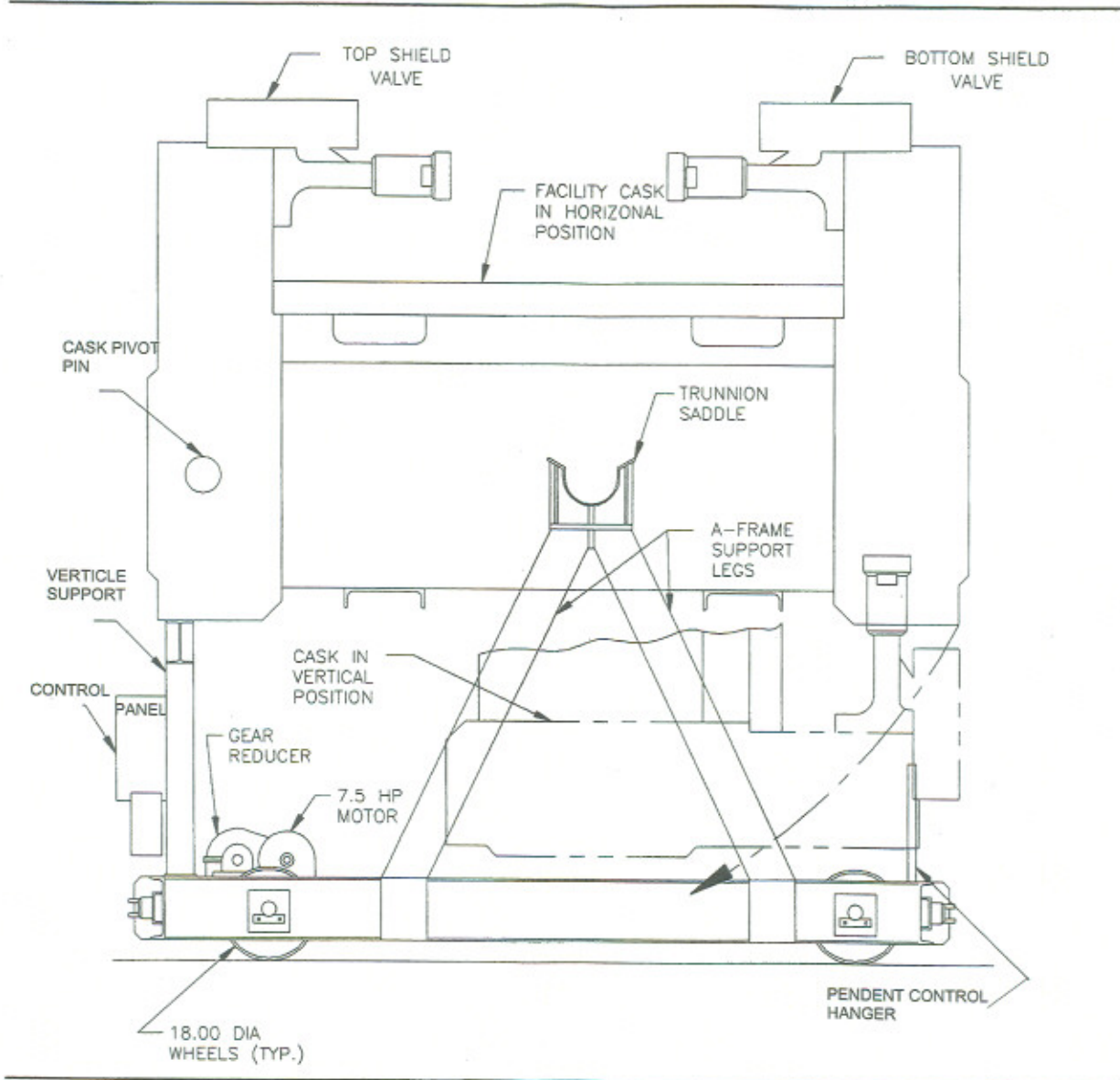

Figure M2-14
Facility Cask Transfer Car (Side View)

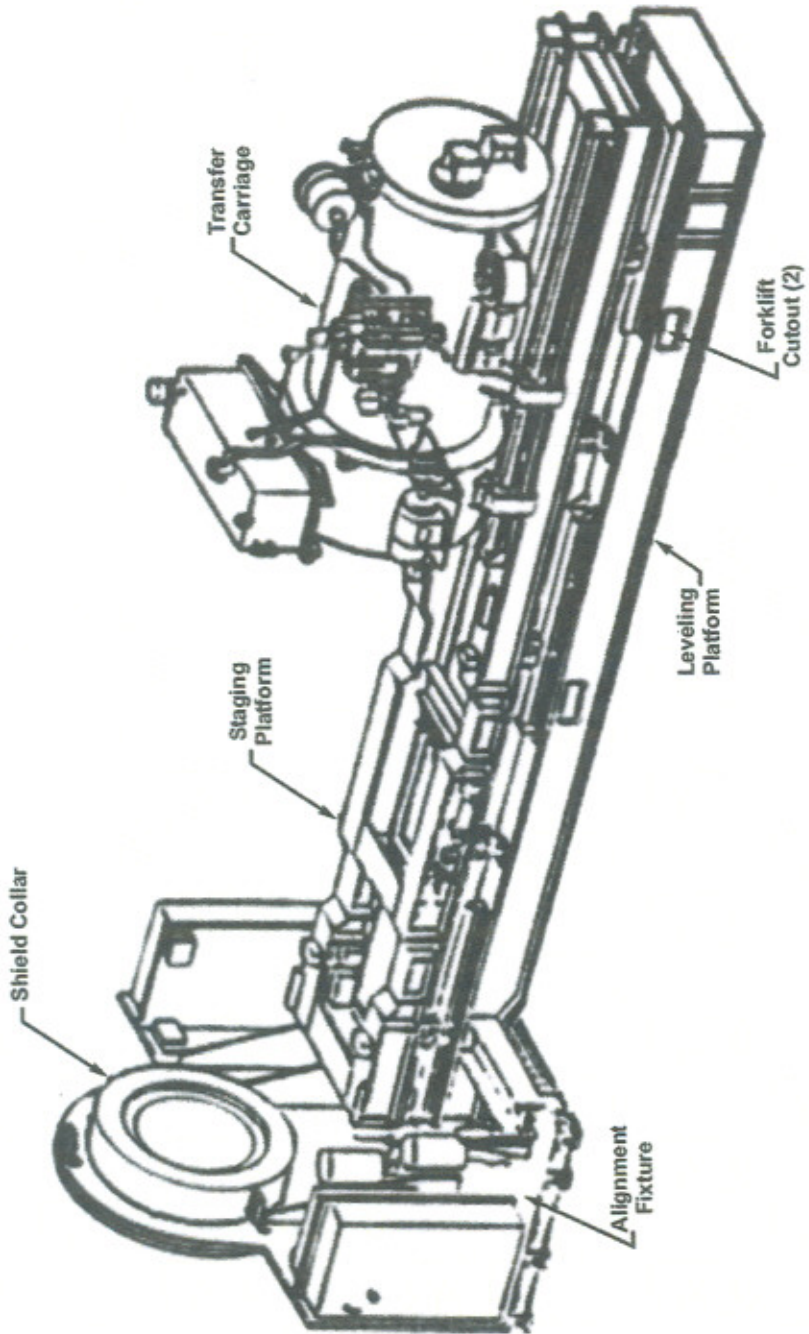

Figure M2-15
Horizontal Emplacement and Retrieval Equipment

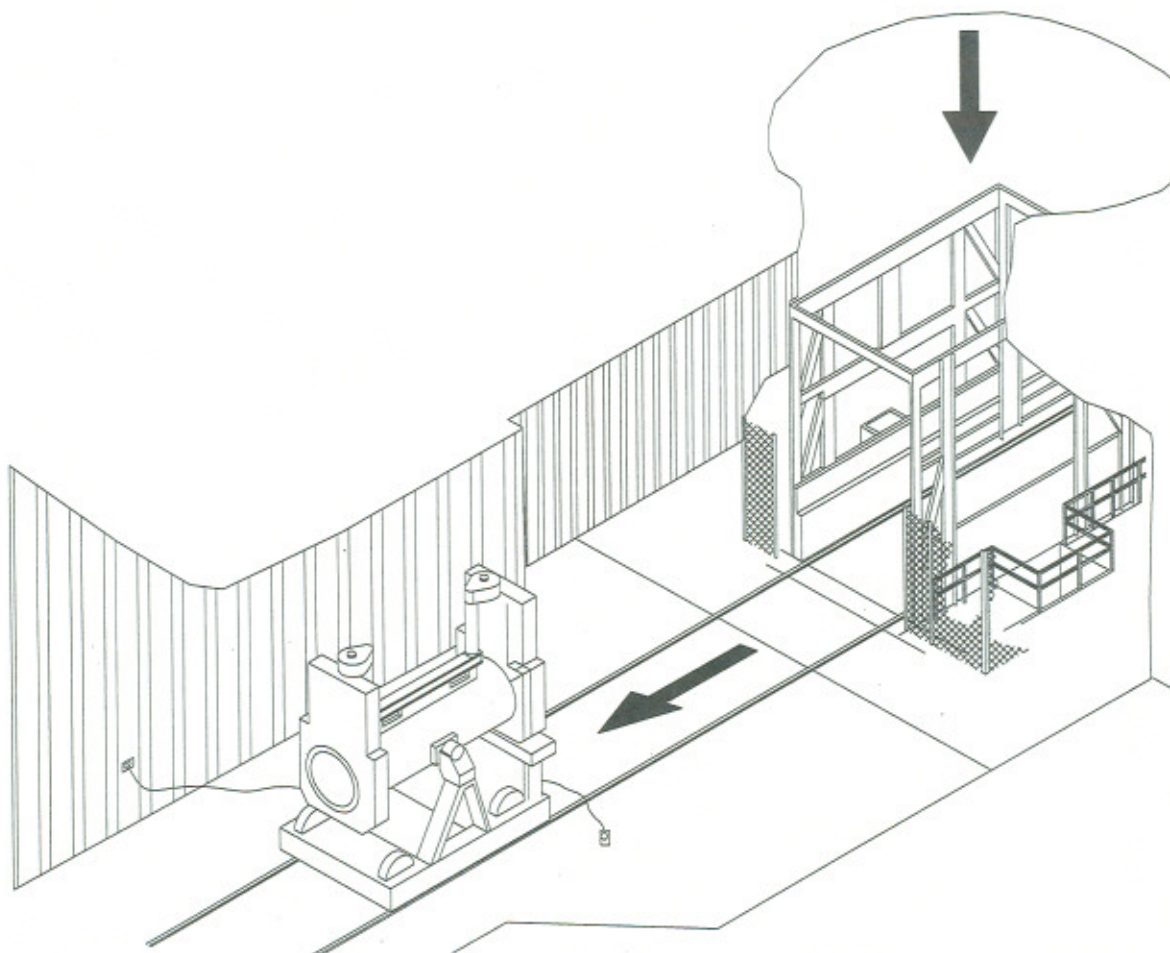

Figure M2-16
RH TRU Waste Facility Cask Unloading from Waste Hoist

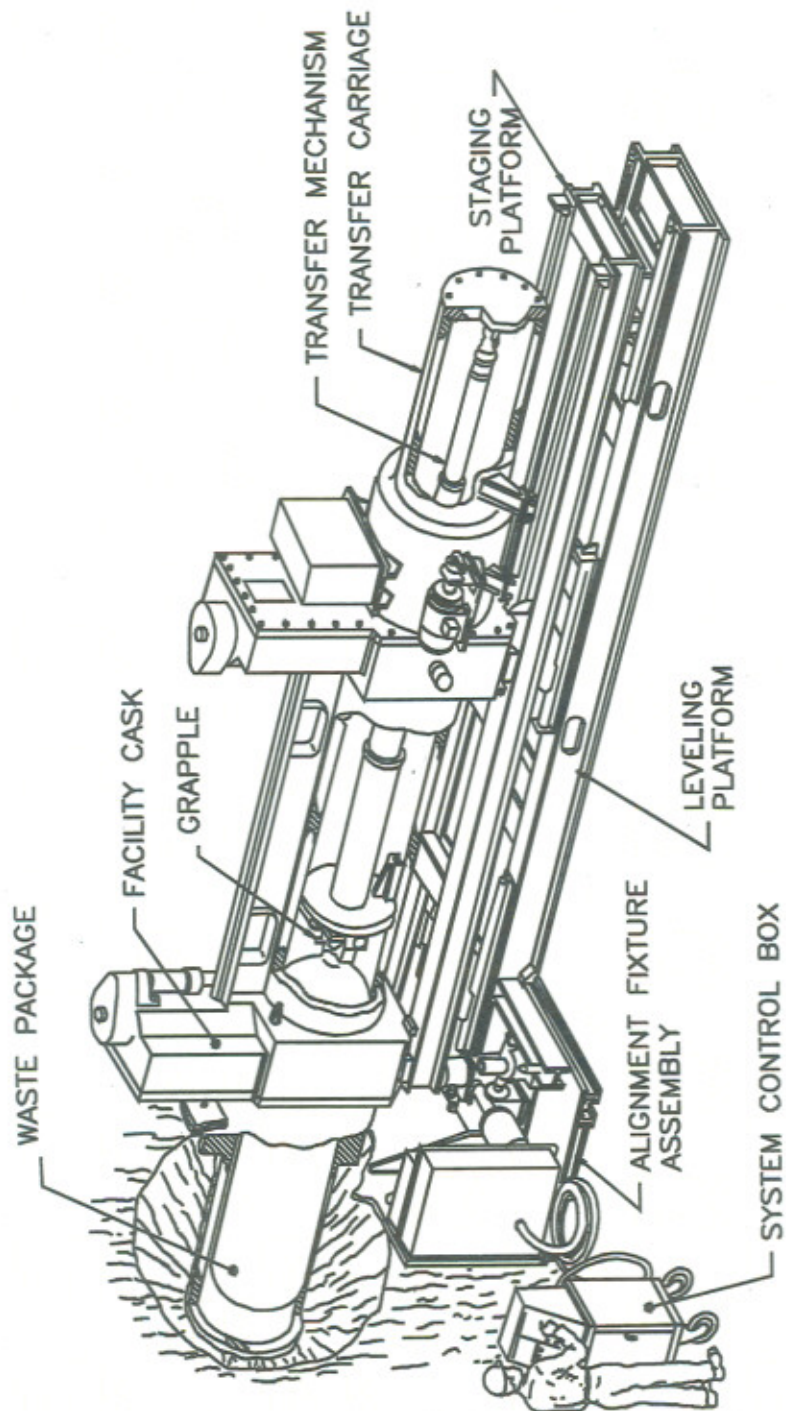

Figure M2-17
Facility Cask Installed on the Horizontal Emplacement and Retrieval Equipment

FACILITY CASK AGAINST SHIELD COLLAR, TRANSFER CARRIAGE RETRACTED,
SHIELD PLUG CARRIAGE ON STAGING PLATFORM, SHIELD PLUG BEING INSTALLED

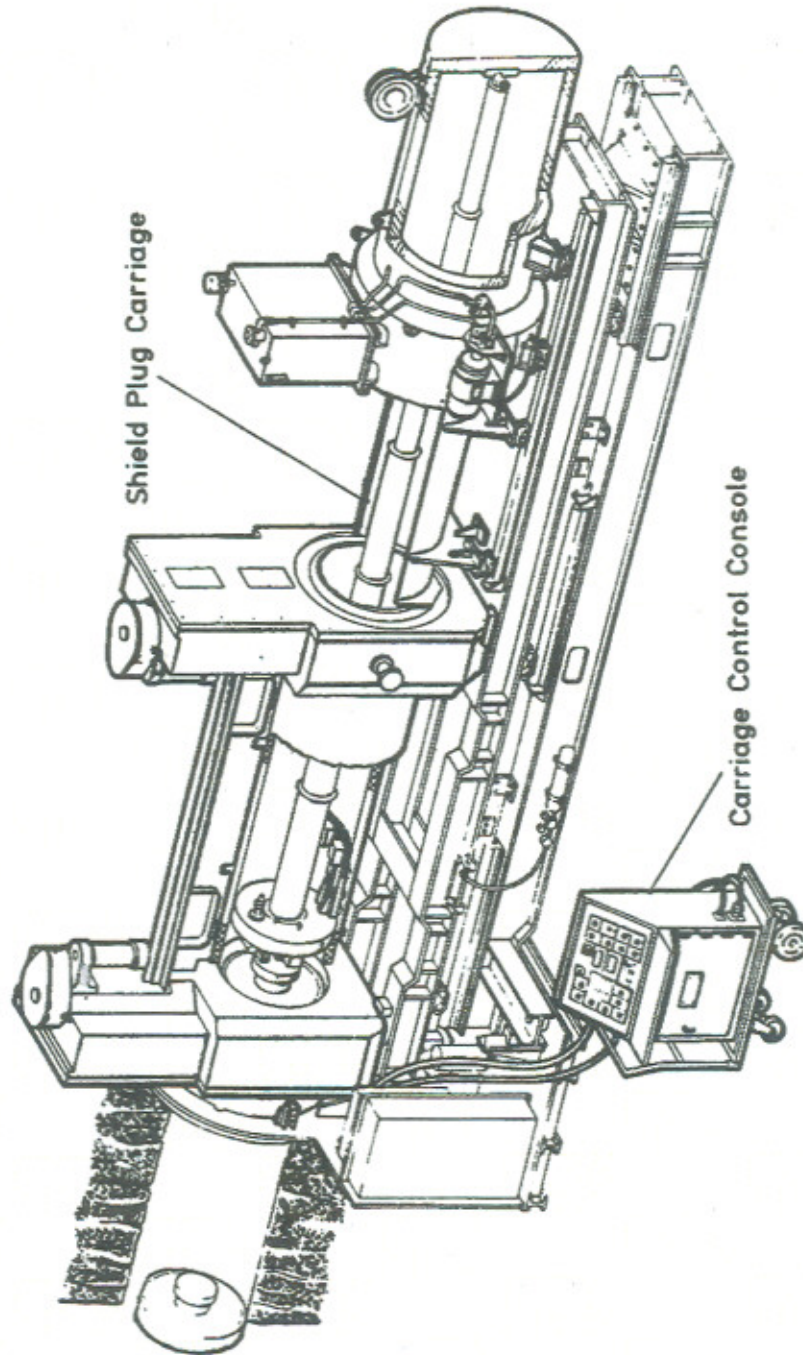

Figure M2-18
Installing Shield Plug