

NEW MEXICO DEPARTMENT OF TRANSPORTATION

# RESEARCH BUREAU

Innovation in Transportation

**STANDARDS FOR TIRE-BALE EROSION  
CONTROL AND BANK STABILIZATION  
PROJECTS: VALIDATION OF EXISTING  
PRACTICE AND IMPLEMENTATION  
HANDBOOK**

Prepared by:  
New Mexico Institute of Mining & Technology  
Department of Mechanical Engineering  
Socorro, NM 87801

Prepared for:  
New Mexico Department of Transportation  
Research Bureau  
7500B Pan American Freeway NE  
Albuquerque, NM 87109

In Cooperation with:  
The US Department of Transportation  
Federal Highway Administration

**NM08MNT-01**

JULY 2012



## US DOT FHWA SUMMARY PAGE

1. Report No. NM08MNT-01	2. Government Accession No.	3. Recipient's Catalog No.	
4. Title and Subtitle  STANDARDS FOR TIRE-BALE EROSION CONTROL AND BANK STABILIZATION PROJECTS: VALIDATION OF EXISTING PRACTICE AND IMPLEMENTATION		5. Report Data	
		6. Performing Organization Code	
7. Authors(s): Ashok Kumar Ghosh; Claudia M. Dias Wilson; Mehrdad Razavi; Bruce Harrison; Maggie Griffin, and Ben Burkhard		8. Performing Organization Report No.	
9. Performing Organization Name and Address  New Mexico Institute of Mining and Technology 801 Leroy Place Socorro, N.M. 87801		10. Work Unit No. (TRAVIS)	
		11. Contract or Grant No.  CO5435	
12. Sponsoring Agency Name and Address  NMDOT Research Bureau 7500B Pan American Freeway PO Box 94690 Albuquerque, NM 87199-4690		13. Type of Report and Period Covered  Final Report April 2011 – July 2012	
		14. Sponsoring Agency Code	
15. Supplementary Notes			
16. Abstract  In an effort to promote the use of increasing stockpiles of waste tires and a growing demand for adequate backfill material in highway construction, NMDOT has embarked on a move to use compressed tire-bales as a means to reduce cost of construction and to recycle used tires which would otherwise occupy much larger space in landfills or be improperly disposed. Compressing the tires into bales has prompted unique environmental, technical, and economic opportunities. This is due to the significant volume reduction obtained when using tire-bales (approximately 100 auto tires with a volume of 20 cubic yards can be compressed to 2 cubic yard blocks, i.e. a tenfold reduction in landfill space). Lighter unit weight, (37 pcf dry), results in lower earth pressure with lesser possibility for foundation failure. The objective of this project is to address the question, "Can tire-bales be used as a cost effective alternate fill material for erosion control and bank stabilization projects?"			
17. Key Words  Tire-bale, Backfill material, Highway		18. Distribution Statement  Available from NMDOT Research Bureau	
19. Security Classif. (of this report)  None	20. Security Classif. (of this page)  None	21. No. of Pages  35	22. Price



**STANDARDS FOR TIRE-BALE EROSION CONTROL AND BANK STABILIZATION PROJECTS:  
ENGINEERING VALIDATION OF EXISTING PRACTICE AND IMPLEMENTATION**

Implementation Handbook on Design and Construction

by

Dr. Ashok Kumar Ghosh, Mechanical Engineering  
Dr. Claudia M. Dias Wilson, Civil Engineering  
Dr. Mehrdad Razavi, Civil and Mineral Engineering  
Dr. Bruce Harrison, Earth and Environmental Science  
Dr. Maggie Griffin, Humanities  
Mr. Ben Burkhard, Mechanical Engineering  
New Mexico Institute of Mining and Technology  
Socorro, NM 87801

Report NM08MNT-01

A Report on Research Sponsored by

New Mexico Department of Transportation Research Bureau

In Cooperation with

The U.S. Department of Transportation

Federal Highway Administration

July 2012

NMDOT Research Bureau  
7500B Pan American Freeway NE  
PO Box 94690  
Albuquerque, NM 87199-4690  
(505)-841-9145

URL: <http://NMDOTResearch.com>

Email: [Research.Bureau@state.nm.us](mailto:Research.Bureau@state.nm.us)



## **PREFACE**

The disposal of tires is a recognized problem around the world. Recycled tires are suitable for a wide range of applications in civil engineering. Their low density makes them suitable as lightweight fill material. They can be used in a variety of forms. The objective of this study is to develop relevant design and construction specifications that will provide confidence to the designers/contractors to use tire bales as a filling material for erosion control and bank stabilization.

## **NOTICE**

The United States government and the State of New Mexico do not endorse products or manufacturers. Trade or manufactures' names appear herein solely because they are considered essential to the object of this report. This information is available in alternative accessible formats. To obtain an alternative format, contact the NMDOT Research Bureau, 7500B Pan American Freeway NE, PO Box 94690, Albuquerque, NM 87199-4690, (505)-841-9145

## **DISCLAIMER**

This report presents the results of research conducted by the authors and does not necessarily reflect the views of the New Mexico Department of Transportation. This report does not constitute a standard or specification.





## ABSTRACT

In an effort to promote the use of increasing stockpiles of waste tires and a growing demand for adequate backfill material in highway construction, New Mexico Department of Transportation (NMDOT) has funded a project on “Standards For Tire-Bale Erosion Control and Bank Stabilization Projects: Validation of Existing Practice and Implementation” to address the question, “Can compressed tire-bales be used as a cost effective alternate fill material for erosion control and bank stabilization projects?” As a part of the deliverables of this project, a handbook containing the specifications for such construction is developed with the purpose to provide quick guides to the design and construction of such structures. This study is performed in two phases. In phase I, two experimental tire bale structures were constructed and studied their effectiveness over time.

Significant volume reduction can result when using tire-bales (approximately 100 auto tires with a volume of 20 cubic yards which when compressed to 2 cubic yard blocks, i.e. a tenfold reduction in landfill space). Tire-bales are lighter, (37 pcf dry), results in lower earth pressure with lesser possibility for foundation failure. Over the course of the project the research team worked to determine the state of the art of tire-bale utilization potential in the USA and abroad. The final report gives a detail description of various aspects on the technology of tire-bale construction.

The design of the tire-bale structure for erosion control requires that the structure be stable under possible loading conditions during the life span of the structure. The primary concern is the intrusion of water behind the structure causing failure. Great care should be taken to control the movement of water across these structures. The contact between the native soil and the fill behind the structure is a weak point. Scouring at the contact between the stream and the structure has the potential for allowing water to get in behind the structure. The general assumption for a tire-bale structure protecting an existing stream bank against erosion is that the base course of tire-bales will be placed such that the top of the lowest tire-bale layer will be at the mean streambed level, and the top of the upper layer will be level with the height of the original bank. It is also assumed that the wall will be ‘pyramidal’ in cross section; each succeeding layer will have one less tire-bale than the layer beneath. The dimensions of each tire-bale is assumed at 5-ft square in plan, with an elevation of 2.5-ft (5’x 5’’x 2.5’).

It is the conclusion of the authors that a blanket ‘banning’ of tire-bales use in erosion control structures found in the U.S. DOTs survey is not warranted, as the development of the failure modes reported can be traced to inadequate structural design (i.e. the tire-bale structures which failed were neither securely anchored, nor wrapped in gabion wire) and inadequate knowledge and control of surface and subsurface water infiltration.

To the best of all the authors’ knowledge, no clear design and construction guidelines exist. This handbook hopes to fill this gap.



## **ACKNOWLEDGEMENTS**

The authors express their appreciation for the invaluable guidance of the NMDOT project Manager, Mr. Virgil N. Valdez. We express our gratitude to Prof. Van Romero, VP. Research and Economic Development for allowing the investigating team to construct the Field Demonstration Facility. The authors are also thankful for the inputs from all the members of the technical panel of advisors for the project including Jesus Estrada, and David Trujillo, Jr. of NMDOT, Toni J. Duggan and Neal Schaeffer of New Mexico Environmental Department, Deanna L. Cummings of the Department of Army, and Ernest Cordova of Cordova and Sons. The authors are also appreciative of Robert Vega, Field Supervisor and Daniel Gallegos, Test Range Lead man of EMRTC, New Mexico Institute of Mining and Technology for their enthusiasm during the construction of the Field Demonstration Facility. Finally, the continual support from Elmira Israilove, and Gayle Baiyle, the Research Accountants at New Mexico Institute of Mining and Technology and Dee Billingsley, Administrator at NMDOT Research Bureau was invaluable.



## TABLE OF CONTENTS

INTRODUCTION .....	2
1.0 REGULATORY REQUIREMENTS .....	4
2.0 MATERIAL CHARACTERISTICS OF TIRE AND TIRE BALE .....	6
2.1 Receipt and Inspection of Tires.....	8
2.2 Handling and Storage of Tires .....	8
2.3 Compressing and Baling .....	9
2.4 Handling and Storage of the Bales.....	9
2.5 Transport, Storage on Site and Placement of the Bales .....	9
3.0 MATERIAL CHARACTERISTICS .....	12
3.1 Wrapping Wire Mesh.....	12
3.2 Geomembrane .....	12
3.3 Stakes and Cables.....	12
4.0 DESIGN REQUIREMENTS .....	14
4.1 Site Drainage.....	14
4.2 Stability of the Overall Structure .....	14
4.3 Design Example .....	15
4.4 Analysis Steps .....	16
4.4.1 Example .....	18
4.5 Factor of Safeties for Overturning and Sliding for a General Case .....	21
4.6 Some Other Design Considerations .....	22
4.6.1 Bearing Capacity .....	22
4.6.2 Slope Stability .....	22
4.6.3 Settlement.....	22
4.6.4 Uplift and Anchor Piles .....	23
4.6.5 Geomembrane Length.....	23
5.0 CONSTRUCTION SPECIFICATIONS.....	24
5.1 Planning and Preparation .....	24
5.2 Equipment .....	26
5.3 Earth work in Cutting, Filing and Compacting.....	26
5.4 Placement of the Tire Bale.....	26
5.5 Wrapping with Wire Mesh.....	26

6.0	RECOMMENDATIONS.....	28
7.0	REFERENCES .....	30
	APPENDIX A.....	31
	Field Demonstration Facility Construction Drawings .....	31

## LIST OF TABLES

<b>TABLE NO</b>	<b>TABLE DESCRIPTION</b>	<b>PAGE</b>
TABLE 1	Physical and Mechanical Characteristics of a Typical Tire Bale ...	7

## LIST OF FIGURES

<b>FIGURE NO</b>	<b>FIGURE DESCRIPTION</b>	<b>PAGE</b>
FIGURE 1	Sample of a Tire-bale.....	6
FIGURE 2	Typical Tire-bale, Tire baler, Tying of a Band.....	8
FIGURE 3	A Schematic Section of the Proposed Tire-bale Structure.....	16
FIGURE 4	Tire-bale Structure Example.....	19
FIGURE 5	Movement of Top-Row Tire-bales.....	21
FIGURE 6	Construction Process for Side Tire-bale Structures.....	25
FIGURE 7	Recommended Stitching of Gabion Wire.....	27
FIGURE 8	Recommended Placement of Gabion Wire with Two Continuous Pieces.....	27





## INTRODUCTION

The handbook is presented as a guide for the design and construction of a tire-bale structure. It also presents various specifications of various aspects of the construction process. The layout of the handbook is as follows:

- i. Regulatory Requirements,
- ii. Material Characteristics,
- iii. Design Basis, and
- iv. Construction issues and specifications.

It should be noted that before installing any tire-bale structure in an ephemeral streambed, prior approval from the U.S. Army Corps of Engineers (Corps) and the New Mexico Department of Environment is required. Chapter 1 presents some relevant information for such approval.

Chapters 2 and 3 provide the physical and mechanical characteristics of the materials used for the two experimental tire-bale structures located at Field Demonstration Facility (FDF) near New Mexico Institute of Mining and Technology campus. Most of the information in Chapters 2 and 3 have been collected from available literature sources.

Chapter 4 illustrates the design requirements based on engineering analysis.

Chapter 5 describes all the steps involved during construction at the FDF site.



## **1.0 REGULATORY REQUIREMENTS**

It is illegal to dump scrap tires in New Mexico. The U.S. Army Corps of Engineers (Corps) and the New Mexico Department of Environment (NMED) will review each project that uses scrap tires and determine the potential impact on water quality. This review process starts by applying for a permit before the actual start of the construction. The Corps and NMED Surface Water Quality Bureau have a joint permit application and NMED Solid Waste Bureau has another required application. The necessary permit forms are available at:

- [http://www.spa.usace.army.mil/reg/Application%20Process/jntwqnm\\_app.pdf](http://www.spa.usace.army.mil/reg/Application%20Process/jntwqnm_app.pdf)
- <http://www.nmenv.state.nm.us/SWQB/>

The process of getting these approvals may take as much as 3 months. Thus, it is necessary that this approval process be initiated more than 3 month prior to the proposed date for starting the construction.



## 2.0 MATERIAL CHARACTERISTICS OF TIRE AND TIRE BALE

Old tires have been used in a variety of applications, for example; residential walls, sound barrier fills, animal fences on farms, barriers for road construction, pavement frost barriers, lightweight embankment fills, and erosion control (1, 2). Two methods of processing discarded tires are shredding or baling. Production of powdered, ground or granulated rubber and splitting of the tires are also commonly employed. The manufacturing of tire-bales is energy efficient; consuming only  $\frac{1}{16}$  of the energy required to shred a similar mass of tires (3). When used whole, tires present little to no pollution problems. When filled with soil or baled, they were found to be fire resistant and very durable in various environments (1). Tire-bales also have been found to have low leaching potential and high chemical and physical durability (4).

This handbook deals with application of tire-bales as a construction material for structures used for erosion control and bank stabilization. Significant volume reduction is obtained when using tire-bales (approximately 100 auto tires with a volume of 20 cubic yards can be compressed to 2 cubic yard blocks, i.e. a tenfold reduction in landfill space). Lighter unit weight, (37 pcf dry), results in lower earth pressure with less possibility for foundation failure.



**FIGURE 1 Sample Tire-Bale**

### **Advantages, Disadvantages And Typical Applications Of Tire-Bales**

#### **Advantages:**

- Comparatively inexpensive to manufacture and install (4).
- Lightweight compared to concrete and riprap, and therefore easier and cheaper to transport and install (3, 5). They can usually be moved and placed using a forklift (4).
- Comparable permeability to gravel (6).
- Good load-bearing capacity (2, 4).

- High chemical and physical durability (1, 4).
- Fire-resistant when coated with a thick layer of non-combustible cement-based material, earthen plaster or stucco. Voids may also be grouted to further reduce the amount of oxygen present (2).
- Low leaching potential (4).
- After being baled for a certain time, they will retain their shape even if some of the wires used to hold the tires together break or are removed (1, 5).

**Disadvantages:**

- Practice not yet well established, causing design to be “somewhat experimental” (4)
- Although tire-bales have been successfully used for erosion control, little information has been published regarding these applications or their design (4).
- Although lightweight, some contractors have found them difficult to place due to the lack of specific lifting points (7).
- Long-term compression and creep rates are still unknown (4).

A Publicly Available Specification, PAS 108, prepared by The British Standards Institution (BSI) (8) in collaboration with Waste & Resources Action Program (WRAP) provides a specification for producing compact tire-bales of a consistent and verifiable quality and dimension. The PAS was prepared following exhaustive consultation from a wide range of stakeholders from the secondary tire industry. PAS 108 provides a specification to be adopted by suppliers for producing tire-bales so that potential customers are assured they are procuring a construction material of consistent and verifiable quality. Thus the core of PAS 108 addresses the production, handling, storage, transport and placement of standardized tire-bales, as well as the dimensions and properties. Additionally, guidance is given on engineering properties and typical construction applications. More information can be found at [www.wrap.org.uk/tyres](http://www.wrap.org.uk/tyres)

Mechanical properties of tire-bales for highway applications.

**TABLE 1 Physical and Mechanical Characteristics of a Typical Tire Bale (6, 9)**

Property	Value (s) with tolerance
Length- <i>l</i>	5 ft (1.33 m)
Width- <i>w</i>	5 ft (1.33 m)
Depth- <i>d</i>	2 ½ ft (0.67 m)
Volume, <i>V</i>	62.5 ft <sup>3</sup> (1.70 m <sup>3</sup> )
Mass, <i>M</i>	1786 lbm (810 kg)
Nominal bulk unit weight, $\gamma$	25 lbf/ft <sup>3</sup> (6.8 kN/m <sup>3</sup> )
Young’s modulus, <i>E</i>	130 ksi (900 MPa)
Angle of inter-bale friction, $\phi_b$	~ 35° and
Hydraulic conductivity through length, <i>k<sub>b</sub></i>	1.18 inch/s (0.03 m/s)

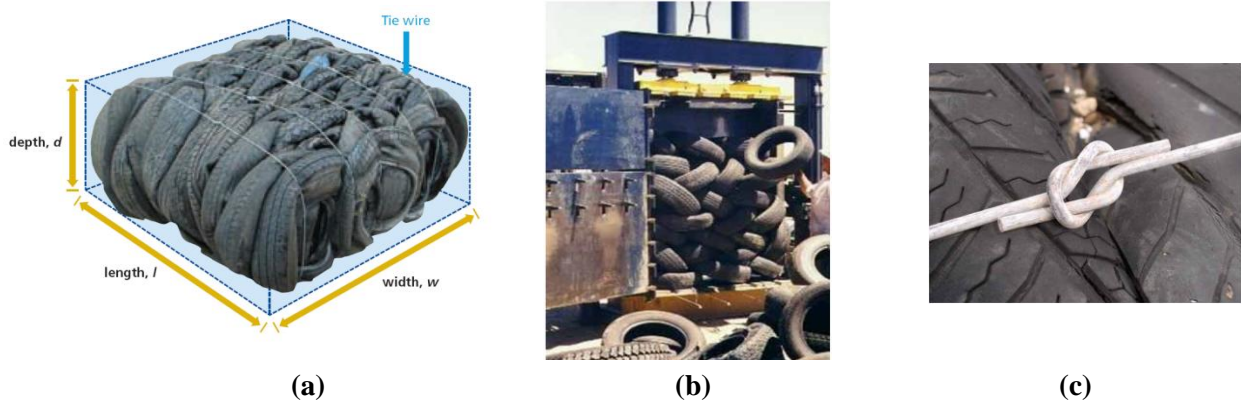

**FIGURE 2 (a) A Typical Tire-bale with 5 Bands; (b) Tire baler in Action; and (c) Tying of a Band.**

## 2.1 Receipt and Inspection of Tires

These specifications are taken from British specifications (PAS 108)

- Tires received for bailing shall be inspected prior to incorporation into bales
- Tires received shall be in a clean and uncontaminated condition. If tires are not in this condition then they must either be rejected or cleaned using a process appropriate to the form of contamination prior to storage and subsequent incorporation into the bales.
- Tires showing damage and exposure of the reinforcing material shall be rejected for the purpose of tire bailing
- Tires showing signs of embitterment and crumbling of the wall or other forms of deterioration shall be rejected.

## 2.2 Handling and Storage of Tires

- Tires shall be handled in such a way as to minimize damage
- Operator shall be equipped with personal protective equipment (PPE) appropriate to the site on which the tires are handled
- Tire bales shall be stored so as to minimize their exposure to sunlight and thus their potential degradation from this cause.

### **2.3 Compressing and Baling**

- Each bale shall be formed from no more than 100 car tires in the United States of America. Truck, four wheel drive and other tires, larger or smaller, shall not be incorporated into tire bales for construction purposes.
- The baler shall be capable of applying forces up to 62.6 tones to the compressed bales.
- Provision shall be made for compressing tires in stages in order to build up the entire bale.
- Provision shall be made to wrap five (5) tie-wires around the bale when it is under maximum compression. These shall comprise galvanized steel wires of 4mm diameter, 12 foot long and electro-galvanized to a thickness of 3µmm to 5µmm (tensile strength 220-250 ksi).
- The tires will be stacked in the baler using a herring-bone arrangement until it is full prior to compression. This process shall be repeated until the requisite number of tires has been incorporated.
- The tie wires shall then be fitted to the bale such that they are approximately parallel around the perimeter of the bale. The bale shall be removed from the baler.

### **2.4 Handling and Storage of the Bales**

- Tire bales shall never be lifted by the tie-wires. The use of a ‘loggers-clam’ is recommended for this purpose. It is also recognized that a conventional back hoe bucket or forklift can be successfully used, but care is required to avoid damage to the tie-wires.
- Tire bales shall be stored so as to minimize their exposure to sunlight and thus their potential degradation due to UV-exposure.
- The stacking of the tire-bales shall be arranged to ensure stability of the stack. Wood bolsters under the first layer of bales should be used to help lay back the front face of the stack to aid in stability. Subsequent layers of bales shall be stacked to form a stretcher bond pattern.

### **2.5 Transport, Storage on Site and Placement of the Bales**

- During transport, site storage and placement in construction works tire bales shall never be lifted by the tie-wires. The use of a ‘loggers-clam’ is recommended for this purpose. It is also recognized that a conventional backhoe bucket or forklift, where appropriate, can be successfully used, but care is required to avoid damage to the tie-wires.



- The placement of tire bales in construction should be such as to ensure that the tie-wires are parallel to the direction of maximum confinement.



## **3.0 MATERIAL CHARACTERISTICS**

### **3.1 Wrapping Wire Mesh**

Both welded wire and twisted wire mesh can be used to tie layers of tire bales. Tensile strength of such mesh should exceed 3000 pounds per linear foot.

### **3.2 Geomembrane**

20 Mil polyvinyl chloride geomembrane liners material that meet or exceed the requirements of ASTM D-7176 standard specification for use in buried application are to be used.

### **3.3 Stakes and Cables**

The 12 foot long steel angle (5" x 5" x 3/4") stakes will be partially driven into the ground. A 3/8" steel cable will be assembled into steel stakes after cable is fastened. It will be tightened across tire-bale groups, and then the steel stakes will be driven the rest of the way into the ground until cable secures tire-bale group into place.



## **4.0 DESIGN REQUIREMENTS**

### **4.1 Site Drainage**

Distresses that were observed at the in-field existing sites, in the form of streambed scour, erosion, and tensile cracking in the backfill soil, indicated that there are areas of concern. The development of saturated backfill, as might occur during a major storm event, would result in hydrostatic forces which could cause overturning. Additionally, scour at the toe (upstream extremity) of the structure can allow water to collect both below and behind the structure. Water collecting under the structure could result in uplift if the underlying soil is expansive, and water collecting behind the structure could result in both overturning hydrostatic forces, and lateral pressure from expansive backfill soil. The contact between the native soil and the fill behind the structure is a weak point and every effort should be made to prevent water entering behind the structure at this point.

### **4.2 Stability of the Overall Structure**

Basic engineering properties of soil such as grain size distribution, Atterberg limits, compaction characteristics, permeability, and shear strength parameters of the soil must be obtained from standard soil mechanics laboratory tests on the representative soil samples. Even if different calculations show that a tire-bale structure is stable under normal circumstances, it is necessary to tie the entire structure to a series of anchor piles. In order to transfer lateral and uplift forces to the anchor piles effectively. Integrity of the structure must be improved by wrapping the bales in a layer of steel wire mesh or the other applicable methods.

The possibility of saturated backfill must be considered in the design process. These structures are designed to be used in ephemeral streambeds ( a streambed that does not carry water year round), and the nature of these features is that they are subjected to intermittent high water flows. While designing the structure to exclude water (using surface berms or geosynthetic barriers), there is no way that water intrusion in the backfill can be prevented over the life of the project (or that once present, it can be economically removed).

### 4.3 Design Example

Before outlining a design procedure, one must first set ‘ground rules’.

- The tire-bales used should be of a uniform size, within allowable tolerances as given in Table 1.
- The tire-bale structure shall be wrapped in gabion wire (a steel wire mesh that is used in gabion wire baskets which holds the structure together as a single unit).
- The structure will be anchored into the soil using cables connected to steel angles acting as driven piles, or their equivalent as shown in Figure 3 below. (For more detail on dimensions refer to Appendix A)

There are additional recommendations which have not been used on previous New Mexico tire-bale projects, but which are recommended by the present research

- The tire-bale structure should be covered in geosynthetic to prevent water intrusion.
- The tire-bale structure should be covered with reinforced soil (i.e., native soil mixed with not less than 10% Portland cement)

The use of a geosynthetic is intended to prevent water from collecting in the void spaces of the structure, and, more importantly, from collecting in the backfill and therefore applying hydrostatic pressure to the structure. The following design methodology will therefore include analyses, which assume that the soil behind the structure can become saturated.

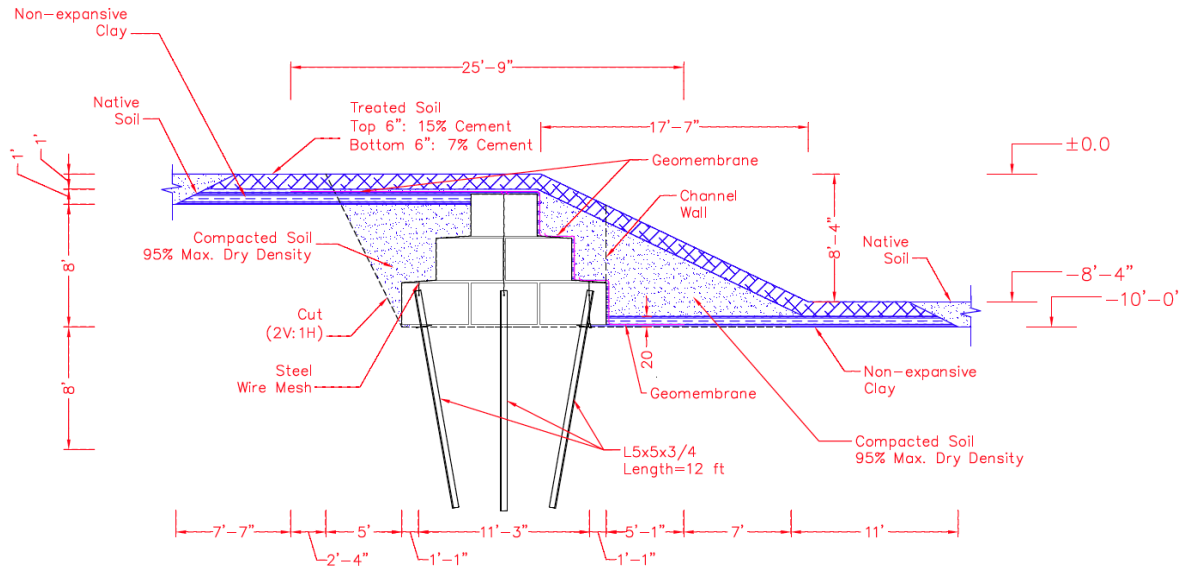

**FIGURE 3 Schematic Section of the Proposed Tire-bale Structure**

#### 4.4 Analysis Steps

The design of a tire-bale structure begins with the determination of the required height, and knowledge of the backfill density and slope. In most cases native soil will be used, though ideally, approved cohesion less backfill material should be chosen.

Whatever backfill material is used, proper compaction (around 95%) should be attained to prevent the development of soil distress and failure in the backfill.

In beginning the analysis, one must first consider the active soil pressure provided by the backfill. The Rankine model is most suited for 'low' structures'. The coefficient of active soil pressure is given as  $K_a$ , with  $\phi$  as the soil's angle of internal friction.

$$K_a = \frac{1 - \sin \phi}{1 + \sin \phi}$$

For most sandy soil, an internal friction angle of  $30^\circ$  can be assumed, giving  $K_a=0.333$ . For sloping backfill, the value of  $K_a$  decreases with increasing slope.

The effective vertical overburden pressure must now be considered. It is the effective weight of the soil above the point of consideration, and will relate to the lateral soil pressure. The effective vertical pressure from soil and groundwater is

$$\sigma'_v = z\gamma + z'\gamma'$$

In the above equation  $z$  is the depth of soil,  $\gamma$  is the unit weight of soil,  $z'$  is the groundwater depth, and  $\gamma'$  is the weight of water (when the possibility of water intrusion is considered).

The lateral soil pressure at a depth  $z$  is equal to the vertical soil pressure times  $K_a$ . Therefore, the pressure in dry soil at the base of a wall of height  $H$  is given as

$$\sigma_a = K_a\gamma z$$

If a linear pressure distribution with depth is assumed, the pressure distribution for a wall with flat backfill and no surcharge loads can be modeled as a triangle with a base equal to the pressure at the base of the wall, and a pressure of zero at the top. The total force acting on the wall is equal to the integration of this distribution; i.e., the area of this triangle.

$$P_a = \frac{1}{2} K_a\gamma H^2$$

It acts through the centroid of the triangle, at a height  $H/3$  from the base of the wall.

For a tire-bale structure, the greatest threat will come during the time an ephemeral stream is flowing. This may mean that if the geosynthetic is compromised, the backfill may become partially or fully saturated, and therefore water pressure behind the wall must be considered. Water pressure is the same in all directions, so its pressure coefficient is 1, and the pressure simply increases as the unit weight of water ( $\gamma_w = 62.4$  pcf) times the depth. Therefore, the force from water pressure is

$$P_w = \frac{1}{2} \gamma_w H^2$$

This, again, acts at a height of  $H/3$  from the base of the wall.

Since the lower course of tire-bales typically have their tops flush with the level of the stream bed, passive soil pressure can also be developed as the backfill 'pushes' the bales. The Rankine coefficient for passive pressure is

$$K_p = \frac{1 + \sin \phi}{1 - \sin \phi}$$



A typical value for sandy soil with  $\phi=30^\circ$  is  $K_p = 3.0$ . The passive force is calculated in a manner to that outlined above, with  $H_p$  being the height of soil on the ‘passive’ (i.e., stream-bed) face of the wall.

$$P_p = \frac{1}{2} K_p \gamma H_p^2$$

The forces are typically used in units of force per lineal foot along the length of the wall.

The active and passive pressures are used in two analyses: sliding failure, and overturning failure. Sliding failure simply balances the horizontal forces against the wall’s frictional resistance to sliding; in the case of a tire-bale structure with a ‘buried’ bottom course of bales, a sliding failure is very unlikely unless the bottom bales are exposed by scour in the stream-bed. An overturning failure calculates the overturning moment created by the active soil force, resisted by the walls weight and the moment (usually small, and often neglected) generated by passive soil force. Rotation is assumed to occur about the toe of the structure, i.e., the lowest point of the bottom course of bales on the stream-bed side.

For the conservative analysis of a tire-bale structure, the following procedure is recommended, using saturated soil in all cases:

1. Sliding failure analysis, with the assumption that the bottom bales may be exposed by scour
2. Overturning failure
3. Deformation failure, with sliding forces acting on upper rows of bales without consideration of gabion wire or cable anchorage.

In each case factors of safety are calculated. Inadequacies should be addressed by detail design of anchorages.

An example is added in section 4.3.2 to illustrate the steps involved in the design of such structure. It assumes worst-case conditions, in which water has infiltrated behind the tire-bale structure and is able to apply hydrostatic overturning and sliding forces to the structure.

This mode should be considered, as the integrity of water excluding methods such as geosynthetic cannot be ensured at all times through the life of the structure, even with routine preventative maintenance.

#### 4.4.1 Example

Consider a tire-bale structure three bales high, with sandy backfill having a unit weight of 100 pcf (Figure 4). The possibility of backfill saturation is assumed. The tire bales have a unit weight of 32 pcf, and are nominally 2.5 ft high and 5 ft square in plan view. Anchorage and the effects of gabion wire will not be considered.

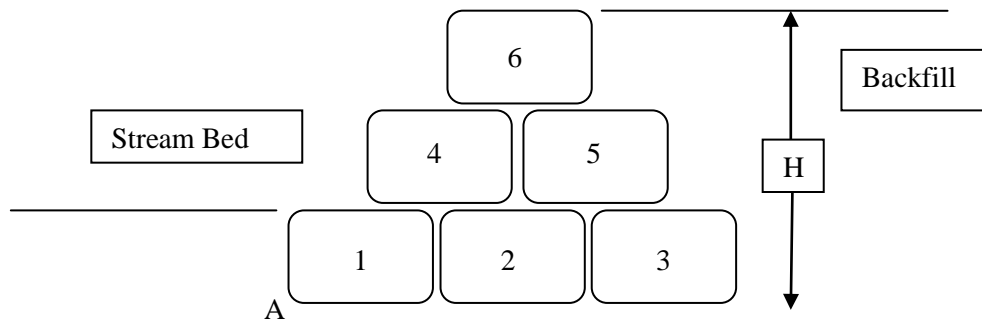

**FIGURE 4 Tire-bale Structure Example**

In this case,  $H = 7.5$  ft, and therefore we have

- $P_a = 928$  lbs per lineal foot of wall
- $P_w = 1775$  lbs per lineal foot water pressure
- $P_p = 938$  lbs per foot of wall
- Weight of bales is 400 lbs per lineal foot per bale

For sliding analysis of the entire wall, we can use a coefficient of friction of 0.75 between the bales and the underlying soil:

- Horizontal force under dry conditions is 928 lbs
- Horizontal force under saturated-backfill conditions is  $928 + 1775$  lbs = 2703 lbs
- Resistance due to bale friction is  $(400 \text{ lbs/bale}) \times 5 \text{ bales} \times 0.75 = 1500$  lbs
- Passive pressure is 938 lbs

Under dry conditions, with no scour, the sliding force is 928 lbs, and the total resisting force is 2438 lbs, giving a factor of safety of  $2438/928 = 2.62$ , which is adequate. Under dry conditions with the bottom bales exposed by scour, the resisting force drops to 1500 lbs, giving a factor of safety of 1.61; still adequate, but barely.

Under saturated-backfill conditions without scour, the sliding force is 2703 lbs, and the resisting force, including passive pressure, is 2438 lbs; the factor of safety is less than unity and the structure is in danger of sliding failure. Clearly, this situation becomes worse if the bottom bales are exposed by scour.

Overturning analysis considers overturning of the structure about its toe, point 'A' in Figure 5.

- Overturning moment of  $P_a$  under dry conditions is  $(7.5 \text{ ft}/3) \times 928 \text{ lbs} = 2320 \text{ lb-ft}$
- Overturning moment of saturated soil is  $(7.5 \text{ ft}/3) \times 2703 \text{ lbs} = 6758 \text{ lb-ft}$
- Resisting moment of Bale 1 is  $400 \text{ lbs} \times 2.5 \text{ ft} = 1000 \text{ lb-ft}$
- Resisting moment of Bale 2 is  $400 \text{ lbs} \times 7.5 \text{ ft} = 3000 \text{ lb-ft}$
- Resisting moment of Bale 3 is  $400 \text{ lbs} \times 12.5 \text{ ft} = 5000 \text{ lb-ft}$
- Resisting moment of Bale 4 is  $400 \text{ lbs} \times 5 \text{ ft} = 2000 \text{ lb-ft}$
- Resisting moment of Bale 5 is  $400 \text{ lbs} \times 10 \text{ ft} = 4000 \text{ lb-ft}$
- Resisting moment of Bale 6 is  $400 \text{ lbs} \times 7.5 \text{ ft} = 3000 \text{ lb-ft}$
- Total resisting moment is  $1000 + 3000 + 5000 + 2000 + 4000 + 3000 = 18,000 \text{ lb-ft}$
- Passive soil force contribution is ignored

Under dry conditions, the factor of safety against overturning is  $18000/2320 = 7.75$ ; under saturated-backfill conditions the factor of safety is  $18000 / 6758 = 2.66$ . Both are entirely adequate.

The deformation condition of movement of individual rows of bales should now be considered (Figure 5).

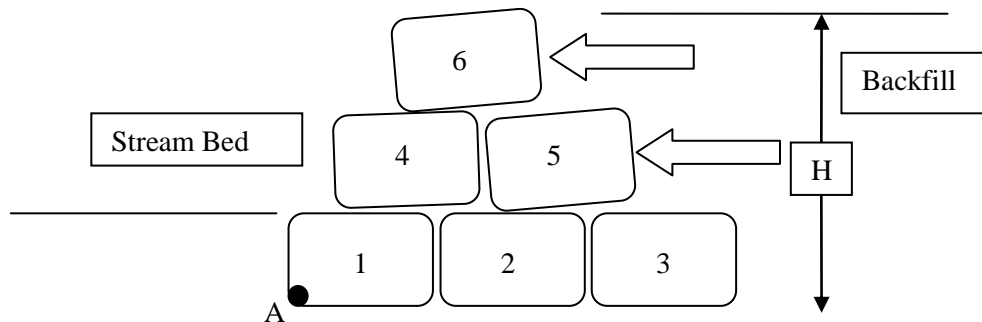

**FIGURE 5 Movement of Top-Row Tire-bales**

We can calculate sliding of the top row of bales (bale 6). The coefficient of friction is assumed at 0.75.

- Active soil pressure under dry conditions is 94 lbs
- Active soil pressure under saturated conditions is  $94 + 195 = 289 \text{ lbs}$

- Resistance to sliding friction is  $400 \text{ lbs} \times .75 = 300 \text{ lbs}$

The top row of bales has a factor of safety against sliding of 3.19 in dry conditions, and 1.03 in saturated conditions. Under dry conditions the factor of safety is fine; it is unacceptable close to potential failure under saturated-backfill conditions

Finally we analyze sliding of the top two rows of bales (bales 4-6).

- Active soil pressure under dry conditions is 375 lbs
- Active soil pressure under saturated-backfill conditions is  $375 + 780 = 1155 \text{ lbs}$
- Resistance to sliding friction is  $3 \times 400 \text{ lbs} \times .75 = 900 \text{ lbs}$

Under dry conditions, the factor of safety is 2.4, which is acceptable. If the backfill is saturated, the factor of safety is 0.78, which is not acceptable.

In summary, we can see that the greatest danger to the structure comes when saturated backfill is acting on the top two rows of bales. If this is the case the bales *will* push forward against the restraining gabion wire. If the wire is not tight enough, and/or this is taking place at the midpoint of the cable between anchors, large deformations can develop which will ‘cascade’ into an overturning failure as the moment arm of the affected bales (about the toe of the structure) is reduced. To improve this design, anchorage should be specifically designed for the vulnerable failure modes identified.

#### 4.5 Factor of Safeties for Overturning and Sliding for a General Case

Assuming a pyramid pattern for a tire-bale structure that has “*m*” layers of tire-bales and by ignoring the weight of the soil on the bales, factor of safety against overturning at level “*i*” is determined by:

$$FS_O = \frac{3W_b(i+1)b}{2K_a\gamma ih^3}$$

Where:

- $FS_O$  = factor of safety against overturning at level “*i*”
- $\gamma$  = unit weight of the soil
- $h$  = thickness of each layer
- $b$  = width of a tire-bale
- $W_b$  = weight of a single bale per unit width
- $i$  = level number

$K_a$  = coefficient of active soil pressure ( $\sim 0.3-1.0$ )

### ***Factor of Safety against Sliding for a General Case***

a. Internal Sliding (between two adjacent layers)

$$FS_{SI} = \frac{(i-1)W_b \tan \varphi_b}{K_a \gamma i^2 h^2}$$

Where  $\varphi_b$  is the average friction angle between the bales. Definitions of the other variables are the same as before.

b. Sliding between the Bales and Foundation Soil

$$FS_{SF} = \frac{[2m(m+1)W_b + m(m-1)\gamma bh] \tan \delta}{K_a \gamma m^2 h^2}$$

Where  $\delta$  is the average friction angle between soil and tire-bales ( $\sim \varphi/2-2\varphi/3$ ;  $\varphi$ = internal friction angle of the soil). Definitions of the other variables are the same as before.

## **4.6 Some Other Design Considerations**

### ***4.6.1 Bearing Capacity***

Since unit weight of the excavated soil is less than the unit weight of tire-bales, bearing capacity is not a major concern. For the same reason consolidation is not an issue either.

### ***4.6.2 Slope Stability***

To check stability of the slope, it is recommended to use a computer program to model the slope including tire-bales to determine the critical factor of safety for all possible failure surfaces.

### ***4.6.3 Settlement***

A good compaction (with a minimum relative compaction of 95%) prevents large settlements. However, a tire-bales structure is a flexible structure and to avoid developing

large tensile cracks, it is strongly recommended to avoid applying large loads to the structure after completing the construction.

#### *4.6.4 Uplift and Anchor Piles*

In case of penetrating water underneath the structure or submerging the bales in water because of an unexpected problem (e.g. puncture of geomembrane, very deep tensile cracks, and soil erosion) uplift pressure develops quickly and the structure might fail in a short time. To avoid this, it is necessary to use several anchor piles around the structure. In addition, structure should have a good integrity to be able to transfer uplift forces to the anchor piles. Wrapping the entire structure in a layer of steel wire mesh increases the integrity of the structure. It is important to notice that design of anchor piles is different for each case due to large number of variables involved.

#### *4.6.5 Geomembrane Length*

Geomembrane must cover the entire structure. The exact length is obtained based on the designed flood, duration of the flood, and travel time of water in soil. However, the extended length of the geomembrane to the back and to the sides should not be smaller than the 25% of the height of the structure from the foundation level. The extended length is measured from the exterior boundaries of the structure at the foundation level. Section 5.5 of reference 1 has detailed description of the process that determines the length of the geomembrane.

## **5.0 CONSTRUCTION SPECIFICATIONS**

Two structures as shown in Appendix A were built according to the design guidelines developed: a system for the head-cutting and another for the side cutting. Construction time, manpower, and equipment used are described in Table 13 of Reference (10). The total construction is divided into a number of activities. Figure 6 illustrates the sequence of these activities and their inter-relationship for the of the side structure. Since breaks are expected every 20ft along the structure and structures to be built in the field often extend for 100ft or more, it is expected that the process described will be used repeatedly. As a result, the construction of each 20ft section is likely to be accelerated as workers gain familiarity with the procedure.

A summary of the labor, equipment, and material used in the construction of test facilities is presented in section 5.7 of the final report (10). Estimated costs for labor, material and equipment are presented in Table 3 of reference 1. The values obtained for this initial cost were based on ...during construction of the field demonstration structures. These values are considered conservative because although the workers were experienced in construction projects, this was their first time working with tire bales. These costs also included rental costs for each piece of equipment for an entire week for the head structure and half a week for the side structure.

### **5.1 Planning and Preparation**

Planning for the construction of the Field Demonstration Facility started at least 6 month before the actual start of the site construction. This planning includes determining how each activity will be sequenced, activity duration, manpower to be deployed at site, necessary equipment. Some of the equipments were available at the Energetic Materials Research and Training Center (EMRTC). The equipments that were not available at EMRTC were rented from local businesses.

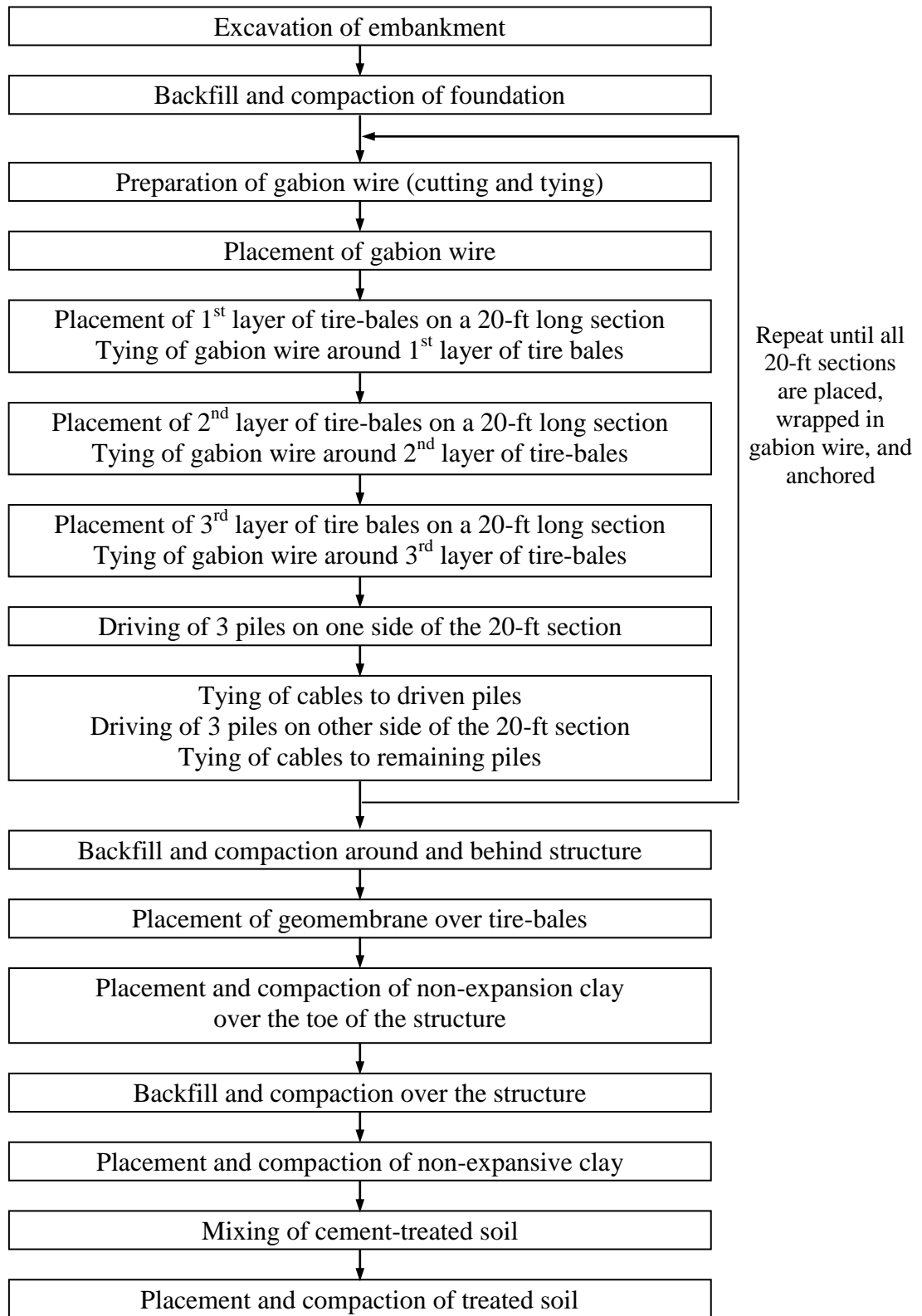

**FIGURE 6 Construction Process for Side Tire-bale Structures**



## **5.2 Equipment**

The following four main pieces of equipment were used for the construction of the structures:

- a TH580B forklift,
- a 330C L hydraulic excavator,
- a 950G Series II wheel loader, and
- a RT 82-SC vibratory trench roller.

The forklift was only used to move the bales from their storage location closer to the construction area, while the excavator was used for excavating, backfilling, mixing soil, lifting and placing the tire bales, and even driving piles once it was equipped with a jackhammer attachment. The loader was used for backfilling and mixing soil. The roller was used to compact the soil. Finally, a nuclear densitometer was used to assure that desired compaction was achieved.

## **5.3 Earth work in Cutting, Filing and Compacting**

Anchor the entire structure to the ground by using at least four anchor piles at the four corners of the structure. Steel cables attached to the anchor piles and passing through the structure transfer the uplift forces to the piles. Any excavation should remain stable until the end of construction.

## **5.4 Placement of the Tire Bale**

Do not put tire-bales on organic soils. Any organic soil at foundation must be removed.

## **5.5 Wrapping with Wire Mesh**

Wrapping of the first and second layers of tire-bales should be performed with a continuous strip of gabion wire. The top row should be secured with a separate piece. Ties should be placed on either side of the first and second rows to secure the tire layers.

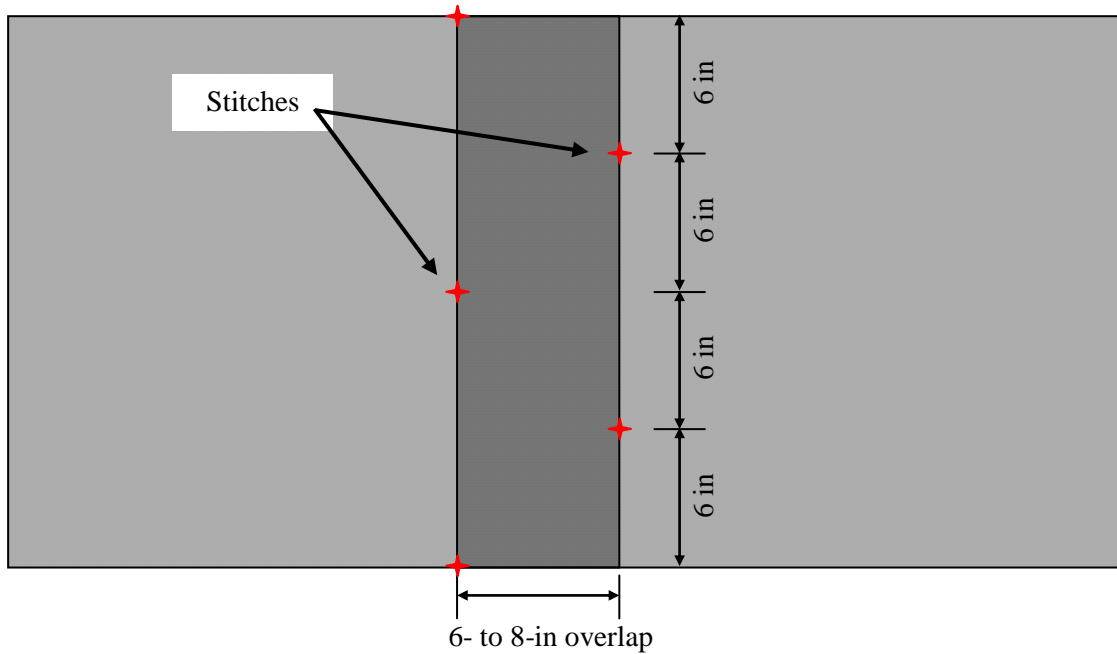

**FIGURE 7 Recommended Stitching of Gabion Wire**

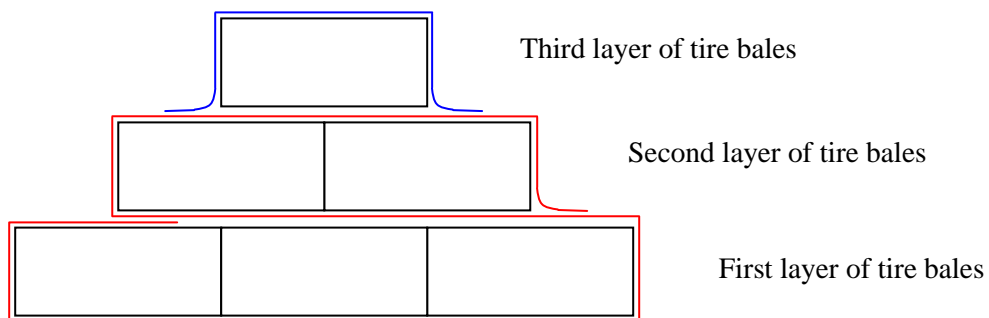

**FIGURE 8 Side view of the Structure Showing Recommended Placement of Gabion Wire with Two Continuous Pieces: (one to wrap first and second layers (red), another to wrap top layer (blue)).**

## 6.0 RECOMMENDATIONS

The recommendations of the research team and technical panel are in the following sections.

Several recommendations during the FDF site construction were made by the construction team: the use of ½” cable would allow the construction crew to apply tension without worrying about cable failure; in addition, if steel piles are to be used instead of concrete piles solid bars would be preferred over angle iron to prevent bending of the piles. The use of appropriate pile driving equipment is also recommended. Alternate stitching of the gabion wires should be used to assure that both flaps are secured. To save time in cutting of the gabion wire, wrapping of the first and second layers of tire-bales should be performed with a continuous strip of gabion wire. The top row should be secured with a separate piece. Ties should be placed on either side of the first and second rows to secure the tire layers. Two 6in layers of soil treated 7% and 15% by weight cement should be used to cover the structures.

The research team recommends addressing problems as soon as they occur and prevent further damage to the structures, site visits for evaluation of existing structures are recommended as follows:

1. Monthly visits should be conducted from the beginning of the snowmelt period (usually April) to the end of the raining season (usually September);
2. Site visits are also recommended after each severe rain event;
3. Finally, if possible, a site visit should be conducted before the snowmelt period to address any damage that may have happened during the fall and winter months.

During these site visits, evaluators should conduct visual inspections of the entire structure, documenting its condition with special attention to the following modes of distress: loose tires, corrosion of baling wires and/or gabion wires, undercutting of bales in middle or the end of the wall, and the presence of tension cracks behind the walls. Probable causes and recommended actions for each mode of distress mentioned above are presented in final report.

Additionally, great care should be taken to control the movement of water across these structures. The contact between the native soil and the fill behind the structure is a weak point and every effort should be made to prevent water entering behind the structure at this point. Similar weak points are the fill associated with culverts included in the structure. These points should be covered with some impermeable barrier. Scouring at the contact between the stream and the structure has the potential for allowing water to get in behind the structure. We recommend that the tire-bale structure be pinned with anchor piles at all corners not just the outside corners.

When designing tire-bale structures the following items are necessary:

1. Do not put tire-bales on organic soils. Any organic soil at foundation must be removed.
2. Foundation soil as well as backfill must be compacted at optimum water content to achieve a minimum compaction ratio of 95%. Backfill soil should be compacted in layers less 12 in. thick.
3. Under-compaction must be avoided. It is necessary to monitor compaction continuously to stop compaction at the recommended compaction ratio.
4. Use a layer of steel wire mesh on the entire structure to hold the bales together.
5. Anchor the entire structure to the ground by using at least four anchor piles at the four corners of the structure. Steel cables attached to the anchor piles and passing through the structure transfer the uplift forces to the piles.
6. Any excavation should remain stable until the end of construction.
7. Expansion index test should be done on the 1 ft clay layer beneath the geomembrane to make sure that the clay is not expansive.
8. Special care in placing geomembrane is necessary to avoid any puncture.
9. A minimum thickness of 20 mil is recommended for geomembrane. When the width of a geomembrane roll is less than the structure length, several pieces of geomembrane should be attached together by overlapping these pieces and using a special tape recommended by the manufacturer.
10. Geomembrane should be extended to the back, to the sides, and to the front of the structure beyond the excavation boundaries. This extension should not be less than 25% of the structure height.
11. Geomembrane should not be exposed to sunlight after the construction period. Applying a layer of treated soil or another proper material on the geomembrane is necessary.
12. In case of using native soil to cover geomembrane, the soil should be treated with a suitable additive such as lime, cement, fly ash, cements kiln dust (CKD), etc. A series of lab tests need to be performed to determine the suitable percentage of the additive by dry weight of the soil.
13. Inspection and maintenance should be scheduled at regular intervals.
14. Follow all current federal and state regulations for the use of tire-bale products and International Fire Code regulations for storage on the job site.

## 7.0 REFERENCES

1. Hoenig, S. A. The Use of Used Tires in Water Systems. *First Interagency Conference on Research in the Watersheds*, Benson, Arizona, 2003, pp.173-176.
2. Jones, L. D. Building with Tire Bales - Addressing Some Engineering Concerns. Innovative Technical Solutions, Littleton, CO., 2005.
3. Winter, M. G., Johnson, P. E., and Reid, J. M. Construction of Road Foundations on Soft Ground Using Lightweight Tyre Bales. *International Conference on Problematic Soils*, Eastern Mediterranean University, Farmagusta, N. Cyprus, 2005.
4. Zornberg, J. G., Christopher, B. R., and Oosterbaan, M. D. Tire Bales in Highway Applications: Feasibility and Properties Evaluation. *CDOT-DTD-R-2005-2*, Colorado Department of Transportation Denver, CO., 2005.
5. Texas Department of Transportation. Design Guidelines on Use of Scrap Tire Bales in Embankment Construction. Texas Department of Transportation, Austin, TX , 2002.
6. British Standards Institution and Waste & Resources Action Programme (WRAP). Introduction to Publicly Available Specification (PAS 108) - Specification for the Production of Tyre Bales for Use in Construction. *PAS 108*, British Standards Institution and Waste & Resources Action Programme (WRAP), 2007.
7. Mackenzie, C., and Saarenketo, T. The B871 Tyre Bale Project - The Use of Recycled Tyre Bales in a Lightweight Road Embankment Over Peat. Roadscanners, Rovaniemi, Finland, 2003.
8. Bureau of Labor Statistics, U.S. Department of Labor. Career Guide to Industries, 2010-11 Edition Construction.  
<http://www.bls.gov/oco/cg/cgs003.htm>  
Accessed June 19, 2010
9. Freilich, Brian and Zornberg, Jorge G. Mechanical properties of Tire Bales for Highway Applications, *FHWA/TX-10/0-5517-1*, October 2008.
10. Ghosh, Ashok Kumar; Dias Wilson, Claudia M.; Budek-Schmeisser, Andrew; Razavi, Mehrdad; Harrison, Bruce; Birbahadur, Naitram; Felli, Profer, and Budek-Schmeisser, Barbara. Standards for Tire-Bale Erosion Control and Bank Stabilization Projects: Validation of Existing Practice and Implementation, Final Report NM08MNT-01, September, 2010.



## **APPENDIX A**

# Field Demonstration Facility Construction Drawings

## Head-Cutting Structure – Sectional view in U.S. Customary Units

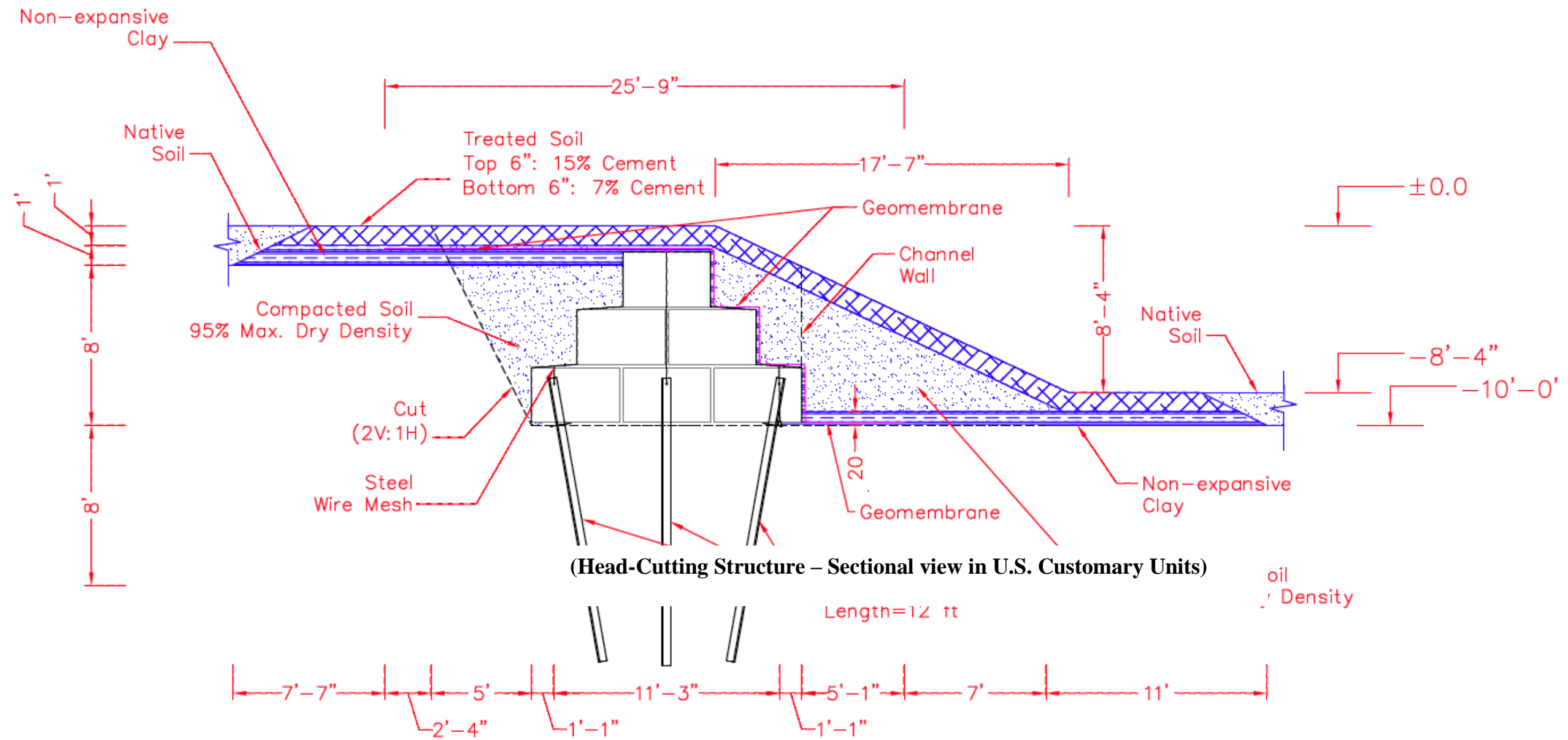



## Head-Cutting Structure – Plan view in U.S. Customary Units

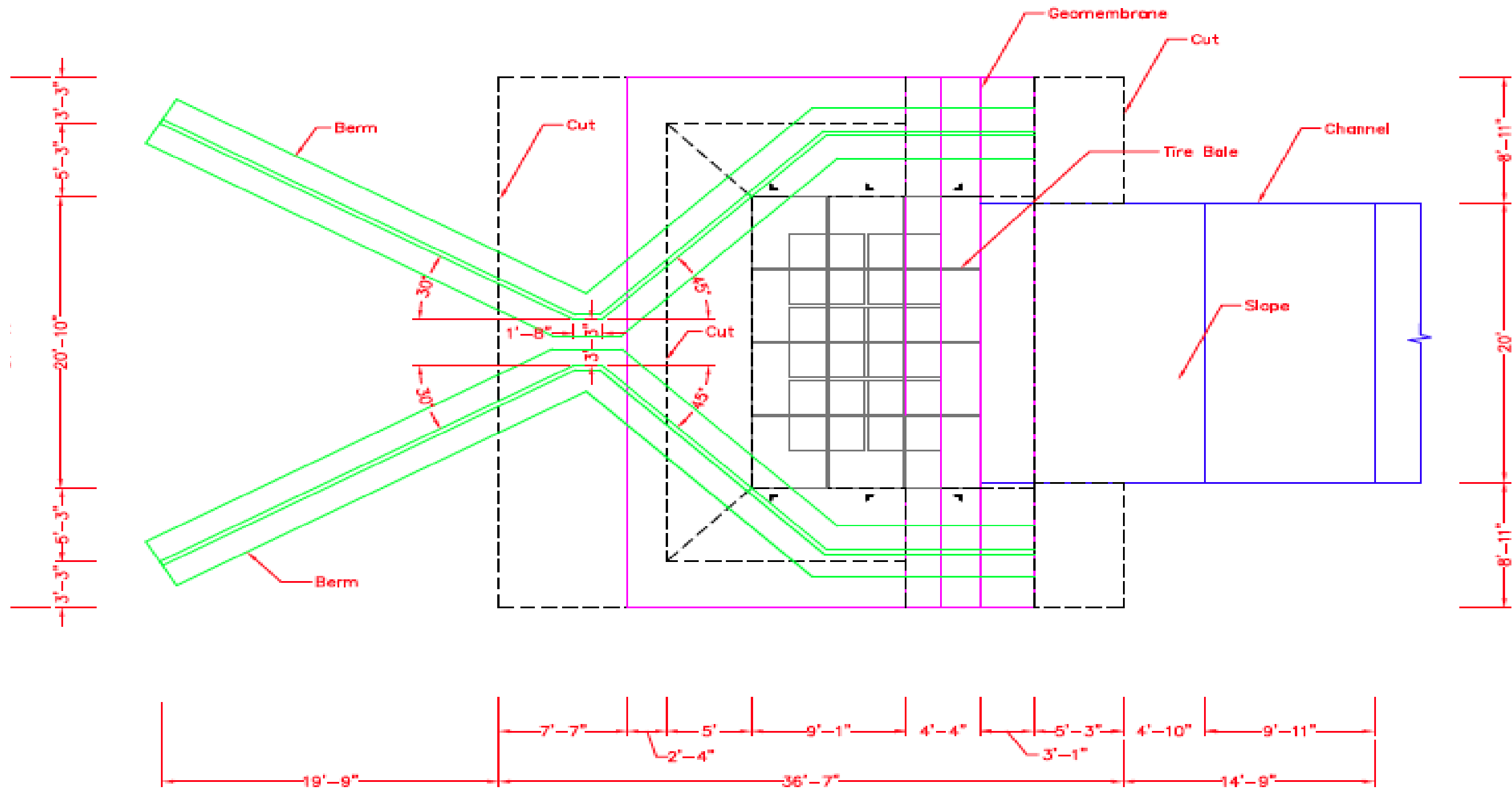

**TOP VIEW**

# Side Structure – Sectional view in U.S. Customary Units

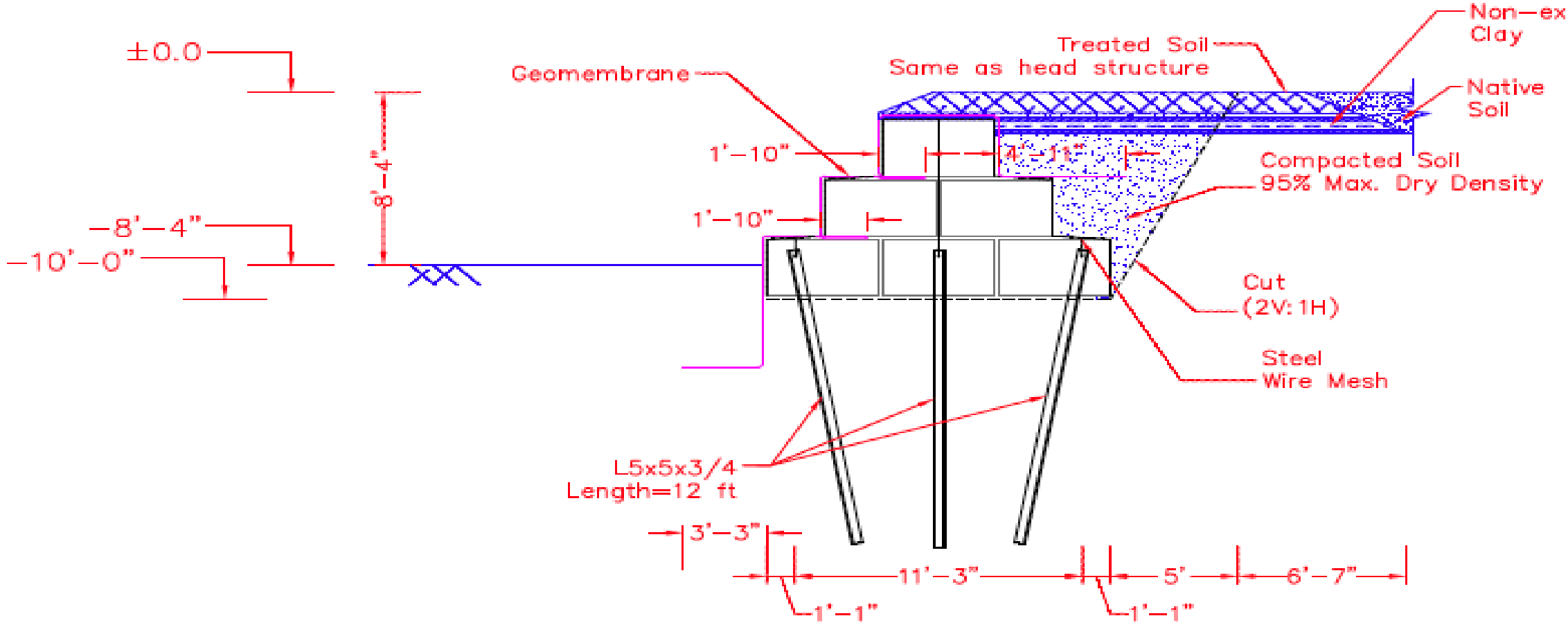

# Side Structure – Plan view in U.S. Customary Units

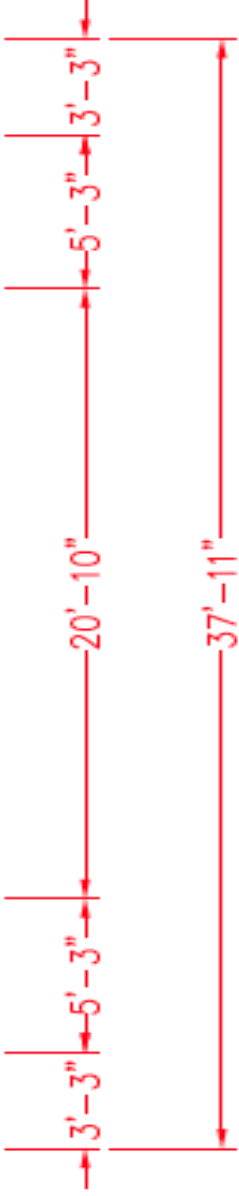
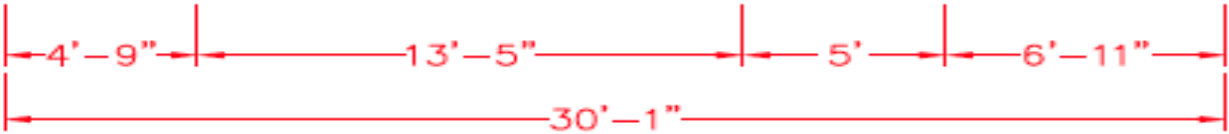
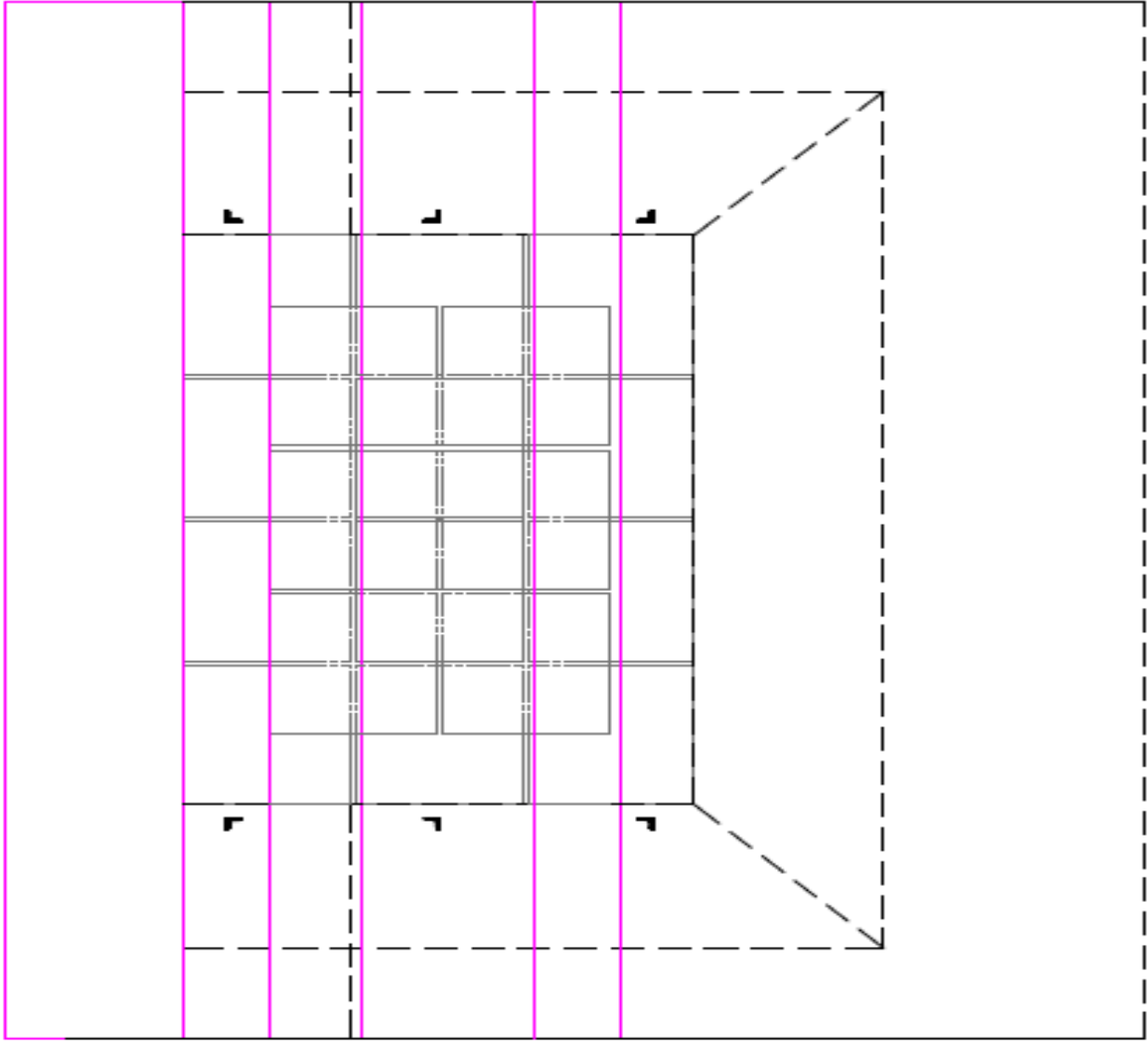



New Mexico Department of Transportation  
RESEARCH BUREAU  
7500B Pan American Freeway NE  
PO Box 94690  
Albuquerque, NM 87199-4690  
Tel: (505) 841-9145