



JUN 17 2003

*Risk Reduction & Environmental Stewardship Division*  
*Water Quality & Hydrology Group (RRES-WQH)*  
PO Box 1663, MS K497  
Los Alamos, New Mexico 87545  
(505) 667-7969/Fax: (505) 665-9344

Date: June 9, 2003  
Refer to: RRES-WQH: 03-125

Mr. Curt Frischkorn  
Pollution Prevention Section  
Ground Water Quality Bureau  
New Mexico Environment Department  
P.O. Box 26110  
Santa Fe, New Mexico 87502

**SUBJECT: RLWTF ANNUAL REPORT FOR 2002**

Dear Mr. Frischkorn:

Please find enclosed the following Los Alamos National Laboratory report: *RLWTF Annual Report for 2002* (LA-UR-03-2728). This report is being provided to your agency as supporting documentation for the Laboratory's Ground Water Discharge Plan Application (DP-1132) for the Radioactive Liquid Waste Treatment Facility (RLWTF) at Technical Area (TA)-50.

The *RLWTF Annual Report for 2002* contains summary information about flows, concentrations, and quantities received and discharged at the three facilities used to treat radioactive liquid wastes (TA-50, TA-21, and TA-53).

Please contact me at (505) 667-7969 should you have any questions or concerns regarding this report.

Sincerely,

A handwritten signature in black ink that reads 'Bob Beers'.

Bob Beers  
Water Quality & Hydrology Group

BB/tml

Enclosures: a/s

Cy: J. Davis, NMED/SWQB, Santa Fe, NM, w/o enc.  
J. Bearzi, NMED/HWB, Santa Fe, NM, w/o enc.  
J. Vozella, DOE/OLASO, w/o enc., MS A316  
G. Turner, DOE/OLASO, w/o enc., MS A316  
M. Johansen, DOE/OLASO, w/enc., MS A316  
J. Holt, ADO, w/o enc., MS A104  
D. McLain, FWO-WFM, w/o enc., MS J593  
R. Alexander, FWO-WFM, w/o enc., MS E518  
B. Ramsey, RRES-DO, w/o enc., MS J591  
K. Hargis, RRES-DO, w/o enc., MS J591  
T. George, RRES-DO, w/o enc., MS J591  
D. Stavert, RRES-EP, w/o enc., MS J591  
C. Nylander, RRES-GP, w/o enc., MS M992  
S. Rae, RRES-WQH, w/o enc., MS K497  
D. Rogers, RRES-WQH, w/o enc., MS K497  
M. Saladen, RRES-WQH, w/o enc., MS K497  
RRES-WQH File, w/enc., MS K497  
IM-5, w/enc., MS A150

JUN 7 2003

**Los Alamos**  
NATIONAL LABORATORY  
**Radioactive Liquid Waste Treatment Facility**  
Mail Stop E518, Los Alamos, NM 87545

AR-RLW-2002

# RLWTF Annual Report for 2002

Effective Date: 5/1/03

Controlled Distribution Date: NA

Next Review Date: NA

	Signature	Date
<b>Report Preparation</b>		
Rich Hassman, FWO-IIM	<i>[Signature]</i>	22 Apr
<b>Reviewer/Process Engineer</b>		
Pete Worland, FWO-WFM	<i>[Signature]</i>	5/1/03
<b>Operations Manager</b>		
Dave Moss, FWO-WFM	<i>[Signature]</i>	05/01/03
<b>Facility &amp; Operations Team Lead</b>		
Rick Alexander, FWO-WFM	<i>[Signature]</i>	5-1-03
<b>Facility Manager/Group Leader</b>		
Dennis McLain, FWO-WFM	<i>[Signature]</i>	5-1-03



YOU ARE RESPONSIBLE FOR VERIFYING THAT YOU ARE WORKING TO THE MOST CURRENT REVISION OF THIS DOCUMENT.

LA-UR-03-2728

JUN 17 2003

Approved for public release;  
distribution is unlimited.

Title: RLWTF Annual Report for 2002

Author(s): Rich Hassman, FWO-IIM  
Pete Worland, FWO-WFM

Submitted to: Facility and Waste Operations Division  
Waste Facilities Management Group  
Los Alamos National Laboratory  
April, 2003



Los Alamos National Laboratory, an affirmative action/equal opportunity employer, is operated by the University of California for the U.S. Department of Energy under contract W-7405-ENG-36. By acceptance of this article, the publisher recognizes that the U.S. Government retains a nonexclusive, royalty-free license to publish or reproduce the published form of this contribution, or to allow others to do so, for U.S. Government purposes. Los Alamos National Laboratory requests that the publisher identify this article as work performed under the auspices of the U.S. Department of Energy. Los Alamos National Laboratory strongly supports academic freedom and a researcher's right to publish; as an institution, however, the Laboratory does not endorse the viewpoint of a publication or guarantee its technical correctness.

Form 836 (8/00)

: 02017

**Table of Contents**

JUN 17 2003

Acronyms and Abbreviations .....4

1. Overview of CY 2002 Activities at the TA-50 RLWTF, the TA-21 RLWTP and the TA-53 RLWTP.....5

2. Description of the TA-50 RLWTF Treatment Process.....7

3. TA-50 RLWTF Influent and Effluent Flows in CY 2002 .....11

4. Radiological Nature of the CY 2002 TA-50 RLWTF Influent and Effluent Waters and Process Waste Sludge .....14

5. Non-Radiological Nature of the CY 2002 TA-50 RLWTF Influent and Effluent Waters and Process Waste Sludge.....29

6. Summary of CY 2002 Operations at the TA-21 RLWTP.....47

7. Summary of CY 2002 Operations at the TA-53 RLWTF.....52

Appendix A: TA-50 RLWTF Monthly Flow Summary..... 53-56

Appendix B: TA-50 RLWTF Daily Flow Summary ..... 57-70

Appendix C: TA-50 RLWTF Monthly Radioisotope Summary ..... 71-83

Appendix D: TA-50 RLWTF Monthly Mineral Summary..... 84-96

Appendix E: TA-50 Plant Feed VOC Results by Sample ..... 97-101

Appendix F: TA-50 Plant Feed VOC Results by Species ..... 102-105

Appendix G: TA-50 Plant Feed SVOC Results by Sample..... 106-108

Appendix H: TA-50 Plant Feed SVOC Results by Species ..... 109-111

Appendix I: TA-50 Plant Sludge VOC Results by Sample ..... 112-114

Appendix J: TA-50 Plant Sludge VOC Results by Species..... 115-116

Appendix K: TA-50 Plant Sludge SVOC Results by Sample .....117

Appendix L: TA-50 Plant Sludge SVOC Results by Species .....118

### List of Figures

2-1	Schematic of the Radioactive Liquid Waste Collection System (RLWCS)....	9
2-2	Schematic of TA-50 RLWTF Treatment Process .....	10
3-1	TA-50 Annual Discharge Volumes (1963 – 2002) .....	13
4-1	Twelve Month Flow Weighted Sum of Ratios of the TA-50 RLWTF Effluent During CY 2002 (DOE Order 5400.5) .....	18
4-2	Gross Alpha Activity in the RLWTF Influent and Effluent During CY 2002 .....	21
4-3	Pu-238 Activity in the RLWTF Influent and Effluent During CY 2002 .....	22
4-4	Pu-239 Activity in the RLWTF Influent and Effluent During CY 2002 .....	23
4-5	Am-241 Activity in the RLWTF Influent and Effluent During CY 2002 .....	24
4-6	Gross Beta Activity in the RLWTF Influent and Effluent During CY 2002.... .....	25
4-7	Sr-90 Activity in the RLWTF Influent and Effluent During CY 2002.....	26
4-8	H-3 and Sr-89 Activity in the RLWTF Influent and Effluent During CY 2002.....	27
5-1	Silicon and TDS in the RLWTF Influent and Effluent During CY 2002 .....	35
5-2	Potassium and Sodium in the RLWTF Influent and Effluent During CY 2002 .....	36
5-3	COD and Calcium in the RLWTF Influent and Effluent During CY 2002 .....	37
5-4	Iron in the RLWTF Influent and Effluent During CY 2002 .....	38
5-5	Mercury in the RLWTF Influent and Effluent During CY 2002 .....	39
5-6	Zinc and Fluoride in the RLWTF Influent and Effluent During CY 2002 ...	41
5-7	Perchlorate and Total Alkalinity in the RLWTF Influent and Effluent During CY 2002 .....	42
5-8	Ammonia-Nitrogen and Nitrate-Nitrogen in the RLWTF Influent and Effluent During CY 2002 .....	43

### List of Tables

3-1	Effluent Discharge Information for the RLWTF During CY 2002.....	11
3-2	TA-50 RLWTF Flow Summary During CY 2002 .....	12
4-1	Mass of Alpha Emitting Radionuclides in the RLWTF Influent and Effluent During CY 2002.....	14
4-2	Radionuclide Analyses of the RLWTF Influent and Effluent in CY 2002. .....	15
4-3	TA-50 RLWTF Gross Alpha Removal in CY 2002 .....	16
4-4	TA-50 RLWTF Radionuclide Summary in CY 2002.....	17
4-5	TA-50 RLWTF Effluent Compared with DCG 5400.5 in CY 2002 .....	19
4-6	TA-50 RLWTF Vacuum Filter Sludge Drums Shipped During CY 2002 . .....	28
5-1	NPDES and NMED Discharge Parameters.....	29
5-2	Discharge Limits for NPDES and NMED Parameters in the RLWTF Effluent .....	30
5-3	TA-50 RLWTF Effluent Compared to NPDES and NMED Standards During CY 2002 .....	32
5-4	TA-50 RLWTF Mineral Summary for CY 2002 .....	33
5-5	VOC/SVOC Detected in Weekly Samples of 2002 RLWTF Influent....	44
5-6	VOC/SVOC Detected in Monthly Samples of 2002 RLWTF Effluent ..	45
5-7	VOC/SVOC Detected in Samples of 2002 RLWTF Sludge.....	46
6-1	Radioisotopes in January 2002 Sample of TA-21 Influent .....	48
6-2	Minerals in January 2002 Sample of TA-21 Influent.....	49
6-3	VOC Detected in January 2002 Sample of TA-21 Influent .....	50
6-4	SVOC Detected in January 2002 Sample of TA-21 Influent.....	51

### Acronyms and Abbreviations

Ci	curie ( $3.7 \times 10^{10}$ disintegrations per second)
CUF	centrifugal ultrafilter
CY	calendar year
DCG	derived concentration guidelines
DOE	United States Department of Energy
EDR	electrodialysis reversal
Final50	composite sample of effluent from the RLWTF
IX	ion exchange
Kg	kilogram
L	liter
LANL	Los Alamos National Laboratory
LDL	less than detection limit
meq/L	milliequivalents per liter
mg/L	milligram per liter
mrem	millirem ( $10^{-3}$ rem)
$\mu$ S/cm	microSiemens per centimeter
nCi/L	nanocuries per liter ( $10^{-9}$ curies per liter)
NMED	New Mexico Environment Department
NMWQCC	New Mexico Water Quality Control Commission
NPDES	National Pollutant Discharge Elimination System
pCi/L	picocuries per liter ( $10^{-12}$ curies per liter)
Pu-239	plutonium isotope with atomic weight of 239
Raw50	composite sample of daily influent to RLWTF via the RLWCS
RLW	radioactive liquid waste
RLWCS	radioactive liquid waste collection system
RLWTF	radioactive liquid waste treatment facility
RLWTP	radioactive liquid waste treatment plant
RO	reverse osmosis
SVOC	semi-volatile organic chemical(s)
TA	technical area
TDS	total dissolved solids
TDS-E	total dissolved solids by electrical conductivity
TUF	tubular ultrafilter
VOC	volatile organic chemical(s)
WETF	Weapons Engineering Tritium Facility



## **1. Overview of CY 2002 Activities at the TA-50 RLWTF, the TA-21 RLWTF and the TA-53 RLWTF**

Los Alamos National Laboratory (LANL) has three facilities for the treatment of radioactive liquid wastes (RLW). Most radioactive liquid wastes are treated at the Technical Area 50 (TA-50) radioactive liquid waste treatment facility (RLWTF). The other two facilities are located at TA-21 and TA-53. During 2002, the TA-50 RLWTF discharged 11.01 million liters of treated water. The TA-21 and TA-53 facilities received 30,280 and 243,038 liters of RLW during 2002, respectively. The RLW received at the TA-21 facility is treated at that location prior to being trucked to the TA-50 RLWTF for final treatment. The RLW received at the TA-53 facility is held in tanks prior to being pumped to solar evaporation basins.

Authorization to discharge effluent water from the TA-50 RLWTF is regulated by the United States Environmental Protection Agency (USEPA) under the National Pollutant Discharge Elimination System (NPDES). The NPDES permit number is NM0028355. The TA-50 RLWTF effluent, for the 3<sup>rd</sup> consecutive year, was in compliance with all twenty-one (21) NPDES water quality parameters during calendar year (CY) 2002.

LANL also has a voluntary commitment with the New Mexico Environment Department (NMED) to not discharge effluent from the TA-50 RLWTF that exceeds groundwater standards set by the New Mexico Water Quality Control Commission (NMWQCC) for three (3) water quality parameters: fluoride, nitrate-nitrogen and total dissolved solids (TDS). One (1) weekly composite sample of RLWTF effluent, though, slightly exceeded the NMED groundwater standard for TDS of 1,000 mg/L (sample was 1,030 mg/L). Process controls have been implemented to ensure that the voluntary commitment is not exceeded again.

Additionally, the TA-50 RLWTF effluent must meet the guidelines of the United States Department of Energy (USDOE) Order 5400.5, "Radiation Protection of the Public and the Environment". During 2002, the RLWTF effluent was in compliance with these guidelines for the 3<sup>rd</sup> consecutive year.

Two forms of solid radioactive wastes (dewatered sludge and cemented evaporator "bottoms" solids) are generated in the treatment of radioactive liquid waste at the TA-50 RLWTF. During calendar year 2002, the TA-50 RLWTF activities resulted in the disposal of 47,088 kilograms (52 cubic meters) of low-level radioactive dewatered sludge from the rotary vacuum filter. Additionally in 2002, 19,906 kilograms of cemented evaporator "bottoms" solids were disposed of at the TA-54 radioactive solid waste disposal facility.

Process related changes and efforts at the TA-50 RLWTF in the year 2002 were:

- the installation and operational startup of the ion exchange system to remove perchlorate from the RLWTF effluent
- the treatment of reverse osmosis concentrate to remove calcium and silica prior to volume reduction by electrodialysis reversal and the evaporator
- the use of sodium permanganate to oxidize the influent wastewater in place of potassium permanganate
- pilot scale testing of brackish water reverse osmosis and seawater reverse osmosis treatment of the concentrate from the main process reverse osmosis unit
- the facility waste acceptance criteria was analyzed and rewritten
- the pilot testing of four (4) membrane filtration technologies; results are published in LA-UR-02-7108
- the plant test in October and November to investigate the performance of the RLWTF treatment process; results are published in LA-UR-03-1222

Besides regular plant operations, several significant operational activities occurred in 2002:

- two evaporator campaigns occurred (June/July and October/November)
- use of a new daily operational log was instituted in July
- clarifier rapid-mix tank mixers replaced
- installed new water cooled high pressure RO pump

Two major facility changes occurred during 2002:

- building 83 was removed from TA-50 in preparation for construction of the new 300,000 gallons influent tank farm
- installation of the sludge mobilization and transfer system for the WM-2 sludge tank cleanout effort was accomplished

## 2. Description of the TA-50 RLWTF Treatment Process

The wastewater treated at the TA-50 RLWTF is composed of radioactive wastes generated in laboratories and facilities at the Los Alamos National Laboratory. No sanitary wastewater is received or treated at the RLWTF. The vast majority of the liquid waste is transported to the TA-50 RLWTF via a double contained pipeline. A small amount of liquid waste is trucked to the RLWTF. Figure 2-1 is a schematic of the radioactive liquid waste collection system (RLWCS), showing technical areas, buildings and programs supported by the TA-50 RLWTF. The RLWCS consists of double contained pipeline and receives wastewater from nearly 1,600 sinks, sumps and tank pump down locations.

Figure 2-2 is a schematic of the treatment process used at the RLWTF. The following paragraphs explain the flow of the treatment processes in use at the RLWTF as shown in Figure 2-2. The TA-50 RLWTF began treating radioactive liquid waste in the summer of 1963. The treatment process from then until late 1999 consisted of the upper five blocks in Figure 2-2: influent tank, rapid mix tank, flocculator / clarifier, sand filter and rotary vacuum filter. The additional treatment processes, shown in the lower half of Figure 2-2, have been incorporated into the treatment process since late in 1999.

Wastewaters are received in the influent tank at the RLWTF. Preoxidation of the influent wastewater is accomplished by adding 15 mg/L of sodium permanganate. The next step in treating the radioactive liquid waste is a coagulation / flocculation / sedimentation process. In this process ferric sulfate and an organic polymer are added to the water to neutralize the negative charges on particulate material in the wastewater. Additional ferric sulfate, lime and sodium hydroxide are added to form a ferric hydroxide precipitate. Another organic polymer is added to aid in the settling process of the precipitate. Typically, as the precipitate material settles in the clarifier, more than 95% of the gross alpha radioactivity is removed from the wastewater. The clarified water then passes through a sand filter to remove additional radioactive particulate material down to 10 microns in diameter. For comparison, the smallest particle visible to the human eye is 30-50 microns in diameter.

The sand filter effluent is then filtered by a tubular ultrafilter, which is able to remove additional radioactive particulate material as small as 0.08 microns in diameter. The permeate from the tubular ultrafilter then passes through anion exchange resin vessels to specifically remove perchlorate from the wastewater stream. Perchlorate removal is the most recent addition to the RLWTF treatment process, being started in March of 2002.

The effluent from the anion exchange vessels is then sent to the effluent tanks or treated by reverse osmosis if additional treatment is required. Reverse osmosis is able to remove dissolved material from water down to 0.0003 micron (3 Angstroms) in size. This is roughly the distance between two water molecules. Reverse osmosis permeate is then sent to the effluent tank. Effluent tank waters are analyzed prior to discharge to ensure compliance with all Federal, State and DOE regulations and guidelines.

As contaminant material is removed from water, secondary waste streams are generated. The sludge formed in the coagulation / flocculation / sedimentation process is dewatered in a rotary vacuum filter. The resultant solid waste is disposed of at the radioactive waste facility at TA-54 at LANL. Filtrate from this process is returned to the influent tank.

Tubular ultrafiltration also generates a secondary waste stream consisting of more concentrated radioactive material. During CY 2002 this secondary waste stream was pumped on a regular basis to the RLWTF influent tank. Early in CY 2003, this waste stream will be sent to the centrifugal ultrafilter, which is capable of filtering liquid streams with higher solids concentrations than the tubular ultrafilter. The concentrated stream generated by the centrifugal ultrafilter will be sent to the rotary vacuum filter. Filtrate from the centrifugal ultrafilter will be returned to the RLWTF influent tank.

Operation of the reverse osmosis unit also produces a concentrate stream, in addition to the permeate stream which goes to the effluent tank. The reverse osmosis concentrate stream is chemically treated to specifically remove silica and calcium. This chemical treatment is accomplished by adding aluminum sulfate, sodium hydroxide, potassium permanganate, and polymers to the reverse osmosis concentrate wastewater and then allowing the precipitated material to settle in a clarifier.

The treated and clarified reverse osmosis concentrate wastewater is then treated by electrodialysis reversal (EDR) which uses direct electrical current to concentrate dissolved contaminants. Product water (less concentrated wastewater) from the EDR is returned to the RLWTF influent tank or used for backwashing the sand filter. The EDR brine (more concentrated wastewater) is further concentrated by an evaporator. Evaporated water is condensed and this distillate is sent to the effluent tank. The concentrated material from the evaporation process, called evaporator "bottoms", is further dried in a drum oven, mixed with cement and disposed at the TA-54 solid waste disposal facility.

Lab shops

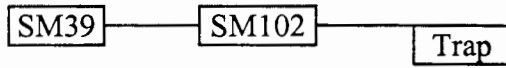

Chemistry  
Metallurgy  
Research (CMR)  
SM 29

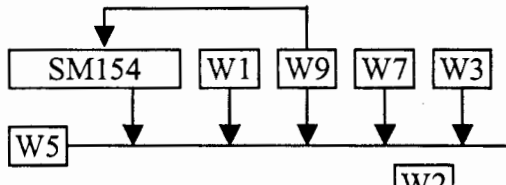

Weapons Test  
Support



Cryogenics



Materials  
Technology

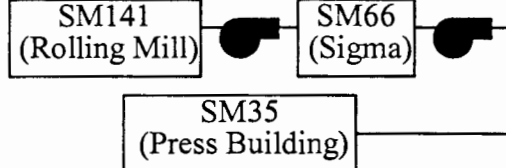

Material Science  
Lab



Unloading Station

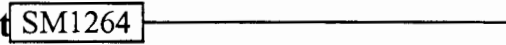

**TA-48**  
*Radiochemistry*

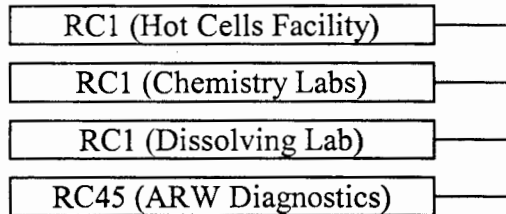

**TA-50**  
*Waste Management Site*

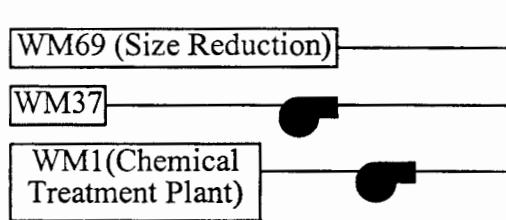

**TA-16**  
*S-Site*

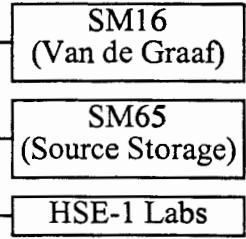
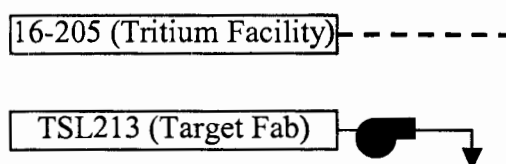

**TA-5!**  
*Health, Safety,  
and Environment*



**TA-21**  
*DP Site*

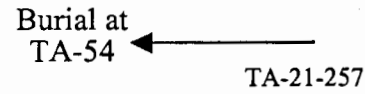

**TA-55**

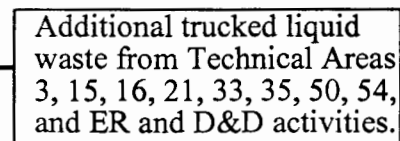
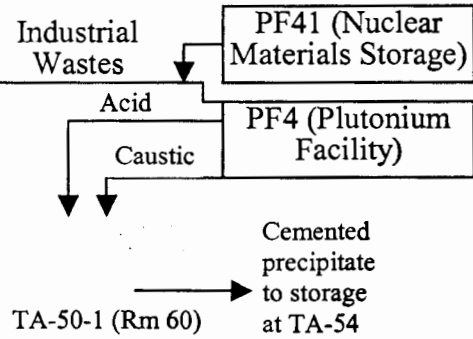

Dewatered, packaged precipitate to burial or storage at TA-54

TA-50-1 (Rms 16 & 116)

Treated waste to Mortandad Canyon



Truck Transport

**Figure 2-2**  
**Schematic of TA-50**  
**RLWTF Treatment**  
**Process**

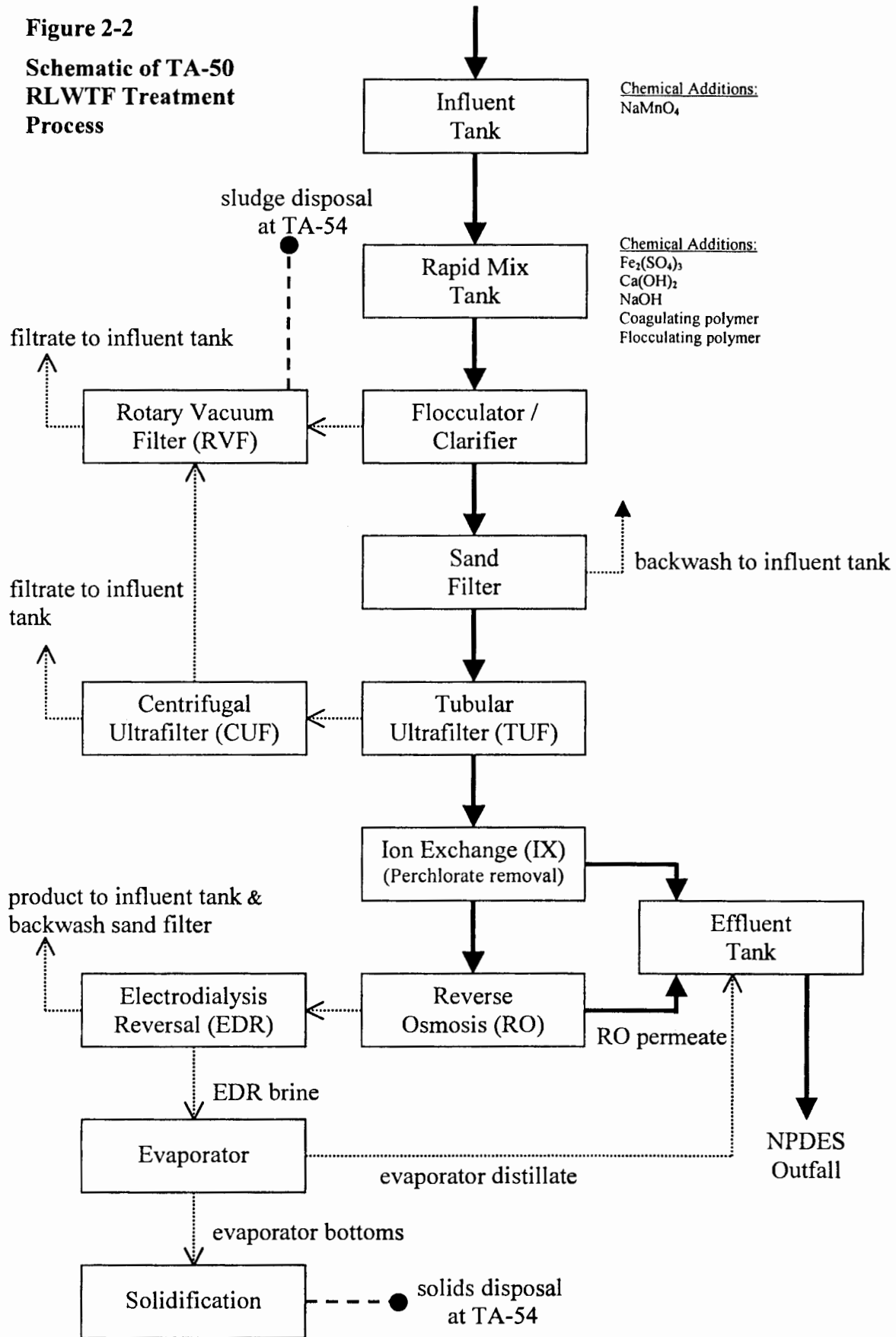

### 3. TA-50 RLWTF Influent and Effluent Flows in CY 2002

During CY 2002, the TA-50 RLWTF received 11,986,052 liters of influent radioactive liquid wastewater. Also, 11,010,203 liters of treated effluent were discharged from the facility via the National Pollutant Discharge Elimination System (NPDES) permitted outfall during CY 2002. Approximately 150,000 liters of evaporator bottoms were further evaporated to dryness and disposed of at the TA-54 radioactive solid waste facility. Appendix A is a tabular summary of the TA-50 RLWTF monthly flows. More detail on daily flows at the RLWTF is provided in Appendix B.

Table 3-1 gives effluent discharge information for the RLWTF during CY 2002. Discharges from the RLWTF via the NPDES permitted outfall occur in batches of approximately 73,000 liters. Each batch discharge, which lasts for approximately 45 minutes, travels via pipeline to Mortandad Canyon which lies just to the north of the TA-50 RLWTF. Batch discharges occur, on average, about three (3) times per week. Table 3-1 also indicates that sixty-two (62) percent of the water discharged in CY 2002 had received reverse osmosis treatment. The other thirty-eight (38) percent of the treated water discharged had met all regulatory discharge requirements with treatment up to and through tubular ultrafiltration and ion exchange.

Table 3-1 Effluent Discharge Information for the RLWTF During CY 2002

Month 2002	# of 051 Discharges	Volume of Discharges (liters)	Percent RO Permeate
January	13	952,068	19
February	8	578,594	76
March	9	657,306	76
April	10	731,754	83
May	14	1,020,837	88
June	16	1,165,296	68
July	20	1,461,654	84
August	12	876,390	63
September	12	873,153	76
October	13	947,978	38
November	13	942,700	41
December	11	802,473	25
<b>2002 Totals</b>	<b>151<sup>a</sup></b>	<b>11,010,203<sup>a</sup></b>	<b>62<sup>b</sup></b>

<sup>a</sup> Daily Operational Logs

<sup>b</sup> Flow weighted 2002 annual average

Table 3-2, shown on the next page, tabularizes the TA-50 RLWTF influent and discharge flows on a monthly basis for CY 2002. Table 3-2 also shows that trucked transfers of water from the TA-21 RLWTF to the TA-50 RLWTF did not occur during CY 2002. Additionally, Table 3-2 indicates that the months of May through August and November were the high flows months of waste to the RLWTF during CY 2002.

TABLE 3-2

**TA-50 RLWTF**  
**FLOW SUMMARY (megaliters)**  
**JAN-2002 through DEC-2002**

Date	Influent	TA-21 Transfer	Discharged
JAN-2002	0.868	0.0	0.952
FEB-2002	0.787	0.0	0.579
MAR-2002	0.821	0.0	0.657
APR-2002	0.827	0.0	0.732
MAY-2002	1.066	0.0	1.021
JUN-2002	1.306	0.0	1.165
JUL-2002	1.354	0.0	1.462
AUG-2002	0.984	0.0	0.876
SEP-2002	0.727	0.0	0.873
OCT-2002	0.906	0.0	0.948
NOV-2002	1.35	0.0	0.943
DEC-2002	0.988	0.0	0.802
<b>TOTAL</b>	<b>11.986</b>	<b>0.0</b>	<b>11.01</b>



Effluent discharges from the TA-50 RLWTF have decreased over the years from 1963 to 2002 as demonstrated in Figure 3-1, which follows. This decrease is the result of programmatic issues as well as the result of efforts to minimize the volume of radioactive liquid waste generation at LANL. Additionally, the removal of non-radioactive liquid wastes from the RLWCS have also reduced the volume of water in the RLWTF influent and, as a result, the effluent.

Figure 3-1 TA-50 Annual Discharge Volumes (1963 – 2002)

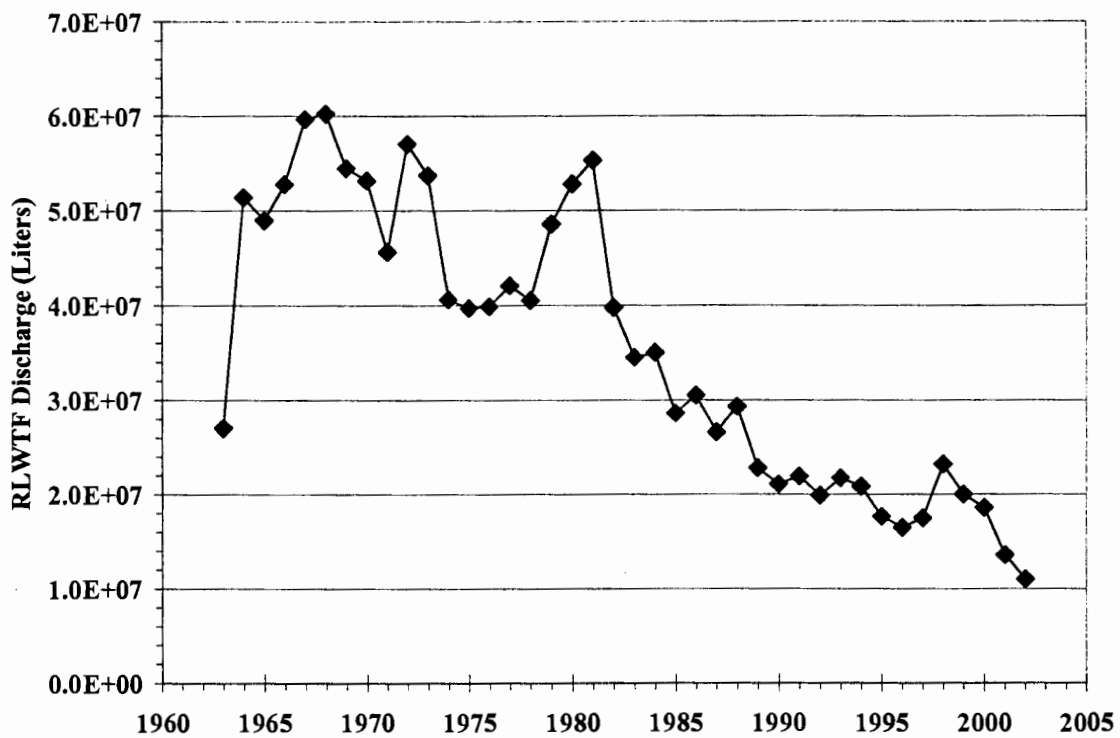

#### 4. Radiological Nature of the CY 2002 TA-50 RLWTF Influent and Effluent Waters and Process Waste Sludge

The influent wastewater to the TA-50 RLWTF is radioactive due to the presence of radionuclides that emit alpha and beta particles, gamma rays and neutrons. Table 4-1 shows the mass of the six (6) major alpha particle emitting radionuclides in the RLWTF influent and also their mass in the effluent from the RLWTF in CY 2002. The table indicates that the treatment process at the RLWTF removes nearly 99.99% of the alpha emitters from the wastewater stream.

Table 4-1 Mass of Alpha Emitting Radionuclides in the RLWTF Influent and Effluent During CY 2002

Mass in CY 2002 Influent (grams)	Alpha Particle Emitting Radionuclide	Mass in CY 2002 Effluent (grams)
0.27	Am-241	0.00004
0.04	Pu-238	0.000005
4.7	Pu-239	0.0004
0.7	U-234	0.001
34	U-235	none detected
10,810	U-238	none detected

There are thousands of naturally occurring and manmade radionuclides. Radiochemists analyze the RLWTF influent and effluent for thirty-nine (39) radionuclides which from past experience are probable in the LANL radioactive liquid waste. Twenty-two (22) of these radionuclides were detected in the RLWTF influent and seventeen (17) were detected at very low activities in the RLWTF effluent in CY 2002. Table 4-2, shown on the next page, summarizes the radionuclides for which analyses are performed and also which radionuclides were detected in the RLWTF influent and effluent during CY 2002.

Table 4-3 presents the removal of gross alpha radiation from the RLWTF influent during CY 2002 on a month by month basis. The total treated volume of water in CY 2002 (11,984,916 liters) is greater than the final effluent volume of water (11,010,203 liters) from the RLWTF because some water required retreatment.

The next table, Table 4-4, is the CY 2002 radionuclide summary for the TA-50 RLWTF. Appendix C displays the monthly radionuclide summaries. The information, in Table 4-4 and Appendix C, is a compilation of analytical information obtained from analyses performed on flow weighted monthly composite samples of both influent and effluent waters. Table 4-4 suggests that tritium removal occurs in the RLWTF treatment processes (raw influent is 11.1 nCi/L and final effluent is 7.2 nCi/L). This apparent removal is an analytical anomaly that is being corrected by the RLWTF radiochemists. In actuality, influent and effluent tritium concentrations are essentially the same.

Table 4-2 Radionuclide Analyses of the RLWTF Influent and Effluent in CY 2002

Radionuclides Analyzed for in the RLWTF Influent and Effluent	Radionuclides Present in RLWTF Influent	Radionuclides Present in RLWTF Effluent
<i>Alpha Particle Emitters</i>		
Am-241	X	X
Np-237		
Ra-226	X	X
Pu-238	X	X
Pu-239	X	X
Pu-240		
U-234	X	X
U-235	X	
U-238	X	
Th-232	X	X
<i>Beta Particle Emitters</i>		
As-74	X	X
Be-7	X	
Ce-141		
Co-56	X	X
Co-57, Co-58 and Co-60		
Cs-134		
Cs-137	X	X
Eu-152		
H-3	X	X
I-133 and Mn-52		
Mn-54	X	
Na-22	X	X
Ra-228	X	X
Rb-83	X	X
Rb-84	X	X
Sc-46, Sc-48, Se-75 and Sn-113		
Sr-85	X	
Sr-89	X	X
Sr-90	X	X
V-48, Y-88 and Y-90		
Zn-65	X	X
<b>39 Total</b>	<b>22 Total</b>	<b>17 Total</b>

TABLE 4-3

TA-50 RLWTF  
Gross Alpha Removal

DATE	RAW (Ci)	FINAL (Ci)	REMOVAL FACTOR $100 \times (\text{INF} - \text{EFF}) / \text{INF}$
JAN-2002	0.081	4.299e-5	99.947
FEB-2002	0.05	2.878e-5	99.943
MAR-2002	0.052	1.716e-5	99.967
APR-2002	0.086	1.523e-5	99.982
MAY-2002	0.111	1.995e-5	99.982
JUN-2002	0.561	3.364e-5	99.994
JUL-2002	0.24	1.654e-5	99.993
AUG-2002	0.157	1.114e-5	99.993
SEP-2002	0.378	5.924e-6	99.998
OCT-2002	0.049	1.611e-5	99.967
NOV-2002	0.069	1.985e-5	99.971
DEC-2002	0.029	1.12e-5	99.962
TOTAL	1.863	2.385e-4	99.987 (average)

Volume of Flow:

Treated = 11,984,916.0 liters

Final = 11,010,203.0 liters

TABLE 4-4

TA-50 RLWTF  
RADIONUCLIDE SUMMARY  
JAN, 2002 through DEC, 2002

	RAW Avg (nC/L)	Maximum (nC/L)	Minimum (nC/L)	Number of Samples	Total (Ci)	FINAL Avg (pCi/L)	Maximum (pCi/L)	Minimum (pCi/L)	Number of Samples	Total (Ci)
ALPHA	181.544	590.0	35.0	12.0	2.176	14.811	42.0	LDL*	12.0	163.069e-6
Am-241	73.982	200.0	13.0	12.0	886.758e-3	10.368	23.0	3.7	12.0	114.158e-6
As-74	5.576e-3	39.0e-3	30.0e-3	4.0	66.828e-6	16.948	36.0	11.0	10.0	186.6e-6
BETA	4.49	25.0	160.0e-3	12.0	53.822e-3	107.9	760.0	LDL*	12.0	1.188e-3
Ba-7	10.436e-3	180.0e-3	180.0e-3	3.0	125.087e-6	LDL*	LDL*	LDL*	7.0	
Ce-141	LDL*	LDL*	LDL*	2.0		LDL*	LDL*	LDL*	7.0	
Co-56	LDL*	LDL*	LDL*	2.0		131.339e-3	2.2	LDL*	8.0	1.446e-6
Co-57	LDL*	LDL*	LDL*	2.0		LDL*	LDL*	LDL*	7.0	
Co-58	LDL*	LDL*	LDL*	2.0		LDL*	LDL*	LDL*	7.0	
Co-60	LDL*	LDL*	LDL*	2.0		LDL*	LDL*	LDL*	7.0	
Cs-134	LDL*	LDL*	LDL*	2.0		LDL*	LDL*	LDL*	7.0	
Cs-137	163.206e-3	1.3	48.0e-3	12.0	1.956e-3	52.827	280.0	19.0	12.0	581.636e-6
Eu-152	LDL*	LDL*	LDL*	2.0		LDL*	LDL*	LDL*	7.0	
I-133	LDL*	LDL*	LDL*	2.0		LDL*	LDL*	LDL*	7.0	
Mn-52	LDL*	LDL*	LDL*	2.0		LDL*	LDL*	LDL*	7.0	
Mn-54	3.998e-3	33.0e-3	33.0e-3	3.0	47.916e-6	LDL*	LDL*	LDL*	7.0	
Na-22	29.877e-3	190.0e-3	9.8e-3	6.0	358.112e-6	5.018	14.0	LDL*	9.0	55.253e-6
Np-237	LDL*	LDL*	LDL*	4.0		LDL*	LDL*	LDL*	11.0	
Pu-238	57.17	180.0	8.1	12.0	685.241e-3	6.669	22.0	2.7	12.0	73.43e-6
Pu-239	23.958	65.0	7.4	12.0	287.16e-3	2.187	4.8	LDL*	12.0	24.078e-6
Ra-226	1.623e-3	28.0e-3	28.0e-3	5.0	19.458e-6	2.609	14.0	LDL*	12.0	28.722e-6
Ra-228	3.465e-3	20.0e-3	18.0e-3	7.0	41.527e-6	1.277	9.4	LDL*	12.0	14.057e-6
Rb-83	2.129e-3	22.0e-3	22.0e-3	3.0	25.519e-6	2.276	35.0	LDL*	10.0	25.055e-6
Rb-84	LDL*	LDL*	LDL*	2.0		343.054e-3	3.7	LDL*	8.0	3.777e-6
Sc-46	LDL*	LDL*	LDL*	2.0		LDL*	LDL*	LDL*	7.0	
Sc-48	LDL*	LDL*	LDL*	2.0		LDL*	LDL*	LDL*	7.0	
Se-75	LDL*	LDL*	LDL*	2.0		LDL*	LDL*	LDL*	7.0	
Sn-113	LDL*	LDL*	LDL*	2.0		LDL*	LDL*	LDL*	7.0	
Sr-85	28.227e-3	230.0e-3	58.0e-3	4.0	338.333e-6	LDL*	LDL*	LDL*	7.0	
Sr-89	2.555e-3	38.0e-3	38.0e-3	12.0	30.627e-6	349.846e-3	4.8	4.8	12.0	3.852e-6
Sr-90	16.277e-3	79.0e-3	27.0e-3	12.0	195.098e-6	299.672e-3	3.5	LDL*	12.0	3.299e-6
TOTAL PLUTONIUM	75.387	245.0	26.4	12.0	903.596e-3	3.343e11	5.6e12	3.3	12.0	3.681e6
TRITIUM	11.129	46.0	7.7	6.0	133.387e-3	7173.65	11000.0	3600.0	12.0	78.983e-3
Th-232	191.789e-6	1.1e-3	130.0e-6	8.0	2.299e-6	3.444e-3	40.0e-3	LDL*	11.0	37.919e-9
U-234	352.962e-3	2.1	26.1e-3	12.0	4.231e-3	573.791e-3	4.6	LDL*	12.0	6.318e-6
U-235	5.686e-3	95.0e-3	1.1e-3	12.0	68.156e-6	LDL*	LDL*	LDL*	12.0	
U-238	302.21e-3	3.5	45.4e-3	12.0	3.622e-3	LDL*	LDL*	LDL*	12.0	
V-48	LDL*	LDL*	LDL*	2.0		LDL*	LDL*	LDL*	7.0	
Y-88	LDL*	LDL*	LDL*	2.0		LDL*	LDL*	LDL*	7.0	
Zn-65	161.37e-3	1.0	25.0e-3	6.0	1.934e-3	726.525e-3	5.4	LDL*	8.0	7.999e-6

Volume of Flow: Influent = 11,986,052.0 liters Final = 11,010,203.0 liters

In 1990 DOE issued Order 5400.5, Radiation Protection of the Public and the Environment, which established revised guidelines for the effluent waters from DOE facilities. The Order identified Derived Concentration Guidelines (DCGs) for all radionuclides discharged from DOE facilities. The concentration of each radionuclide divided by its particular DCG value results in a ratio. For waters containing more than one radionuclide, a ratio will be found for each radionuclide. For a water to be in compliance with Order 5400.5, the sum of the ratios cannot exceed 1.0. The radionuclides of primary concern in the RLWTF effluent are Pu-238, Pu-239, and Am-241. These three isotopes typically account for greater than 90% of the sum of the ratios in the RLWTF effluent.

Compliance with this Order insures that the yearly dose will be less than 100 millirem to a person drinking 2 liters of this water per day. The *millirem* is a unit for measuring the biological effects of radiation on the human body. The average annual radiation dose equivalent to a member of the general population of the United States from both natural and manmade sources is about 361 millirem (mrem). Of this average total radiation dose, 296 mrem is from naturally occurring radiation sources and the remaining 65 mrem is from manmade radiation sources. Figure 4-1 demonstrates that for CY 2002 the RLWTF effluent was in compliance with DOE Order 5400.5.

Figure 4-1 Twelve Month Flow Weighted Sum of Ratios of the TA-50 RLWTF Effluent During CY 2002 (DOE Order 5400.5)

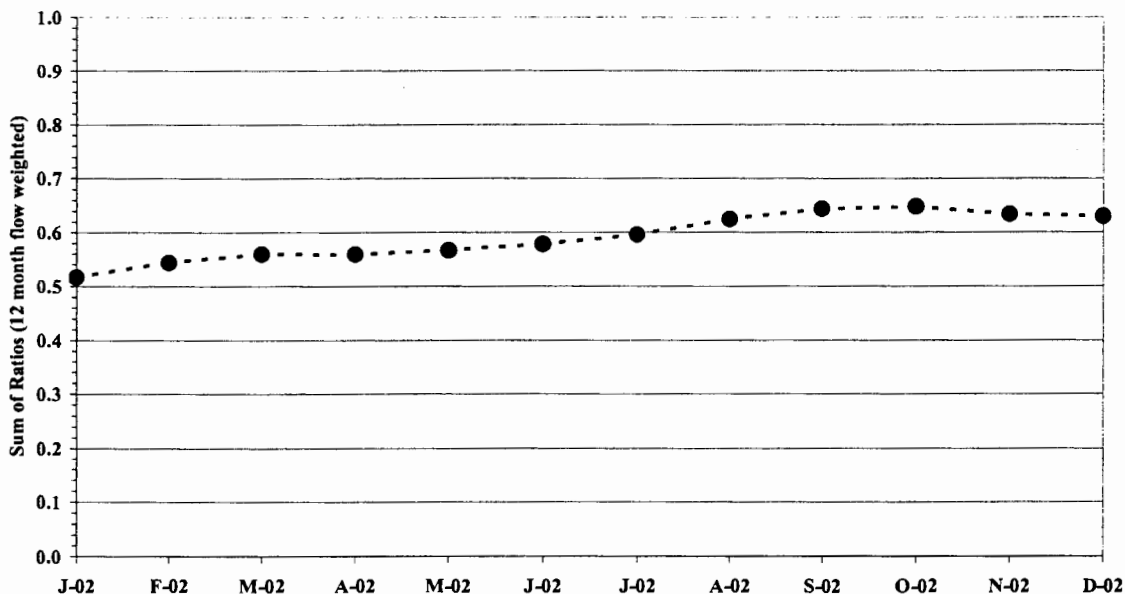

The flow weighted sum of ratios for CY 2002 is 0.648 as shown in Table 4-5 on the following page.

TABLE 4-5

TA-50 RLWTF  
EFFLUENT COMPARED WITH DCG 5400.5

JAN, 2002 through DEC, 2002

Radioactive Isotopes	Mean Concentration (picoCi/L)	DCG 5400.5 (picoCi/L)	Conc/DCG Ratio
Am-241	10.4	30	0.346
As-74	16.9	40,000	4.237e-4
Be-7		1,000,000	
Ce-141		50,000	
Co-56	0.1	10,000	1.313e-5
Co-57		100,000	
Co-58		40,000	
Co-60		5,000	
Cs-134		2,000	
Cs-137	52.8	3,000	0.018
Eu-152		20,000	
I-133		10,000	
Mn-52		20,000	
Mn-54		50,000	
Na-22	5.0	10,000	5.018e-4
Np-237		30	
Pu-238	6.7	40	0.167
Pu-239	2.2	30	0.073
Pu-240		30	
Ra-226	2.6	100	0.026
Ra-228	1.3	100	0.013
Rb-83	2.3	20,000	1.138e-4
Rb-84	0.3	10,000	3.431e-5
Sc-46		20,000	
Sc-48		20,000	
Se-75		20,000	
Sn-113		50,000	
Sr-85		70,000	
Sr-89	0.3	20,000	1.749e-5
Sr-90	0.3	1,000	2.997e-4
TRITIUM	7,173.7	2,000,000	0.004
Th-232	0.0	50	6.888e-5
U-234	0.6	500	0.001
U-235		600	
U-238		600	
V-48		30,000	
Y-88		30,000	
Y-90		10,000	
Zn-65	0.7	9,000	8.072e-5

Sum of Ratios = 0.648

The following series of seven (7) figures highlight significant information which pertains to the radiological nature of the TA-50 RLWTF influent and effluent.

The upper graph in Figure 4-2 shows the gross alpha activity in the raw daily influent water to the RLWTF and the gross alpha activity in the effluent from the RLWTF in monthly composite samples during CY 2002. The lower graph in Figure 4.2 shows more detail on the gross alpha activity in the CY 2002 effluent by changing the scale to picocuries per liter.

The upper graph in Figure 4-3 shows the Pu-238 activity in the raw daily influent water to the RLWTF and the Pu-238 activity in the effluent from the RLWTF in monthly composite samples during CY 2002. The lower graph in Figure 4.3 shows more detail on the Pu-238 activity in the CY 2002 effluent by changing the scale to picocuries per liter.

The upper graph in Figure 4-4 shows the Pu-239 activity in the raw daily influent water to the RLWTF and the Pu-239 activity in the effluent from the RLWTF in monthly composite samples during CY 2002. The lower graph in Figure 4.4 shows more detail on the Pu-239 activity in the CY 2002 effluent by changing the scale to picocuries per liter.

The upper graph in Figure 4-5 shows the Am-241 activity in the raw daily influent water to the RLWTF and the Am-241 activity in the effluent from the RLWTF in monthly composite samples during CY 2002. The lower graph in Figure 4.5 shows more detail on the Am-241 activity in the CY 2002 effluent by changing the scale to picocuries per liter.

The upper graph in Figure 4-6 shows the gross beta activity in the raw daily influent water to the RLWTF and the gross beta activity in the effluent from the RLWTF in monthly composite samples during CY 2002. The lower graph in Figure 4.6 shows more detail on the gross beta activity in the CY 2002 effluent by changing the scale to picocuries per liter.

The upper graph in Figure 4-7 shows the Sr-90 activity in the raw daily influent water to the RLWTF and the Sr-90 activity in the effluent from the RLWTF in monthly composite samples during CY 2002. The lower graph in Figure 4.7 shows more detail on the Sr-90 activity in the CY 2002 effluent by changing the scale to picocuries per liter.

The upper graph in Figure 4-8 shows the tritium (H-3) activity in the raw daily influent water to the RLWTF and the Tritium (H-3) activity in the effluent from the RLWTF in monthly composite samples during CY 2002. The lower graph in Figure 4-8 shows the Sr-89 activity in the raw daily influent water to the RLWTF and the Sr-89 activity in the effluent from the RLWTF in monthly composite samples during CY 2002.

As shown in Table 4-6, a total of 251 drums (47,088 kilograms) of vacuum filter sludge were shipped to the TA-54 radioactive solid waste disposal facility at LANL during CY 2002. Shipments of drums were made in March, May, June, August, and December of 2002. Curies of U-235, Pu-238, Pu-239 and Am-241 associated with the sludge drums is also provided in Table 4-6.



FIGURE 4-2

RAW50 and FINAL50  
ALPHA concentration (nCi/L).  
JAN-2002 through DEC-2002

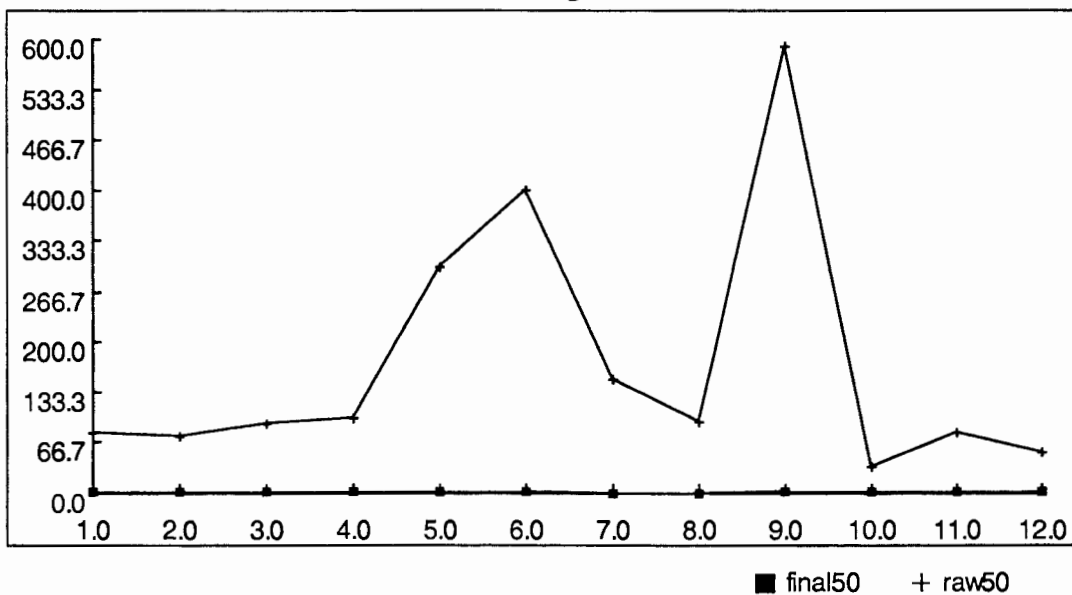

FINAL50  
ALPHA concentration (pCi/L).  
JAN-2002 through DEC-2002

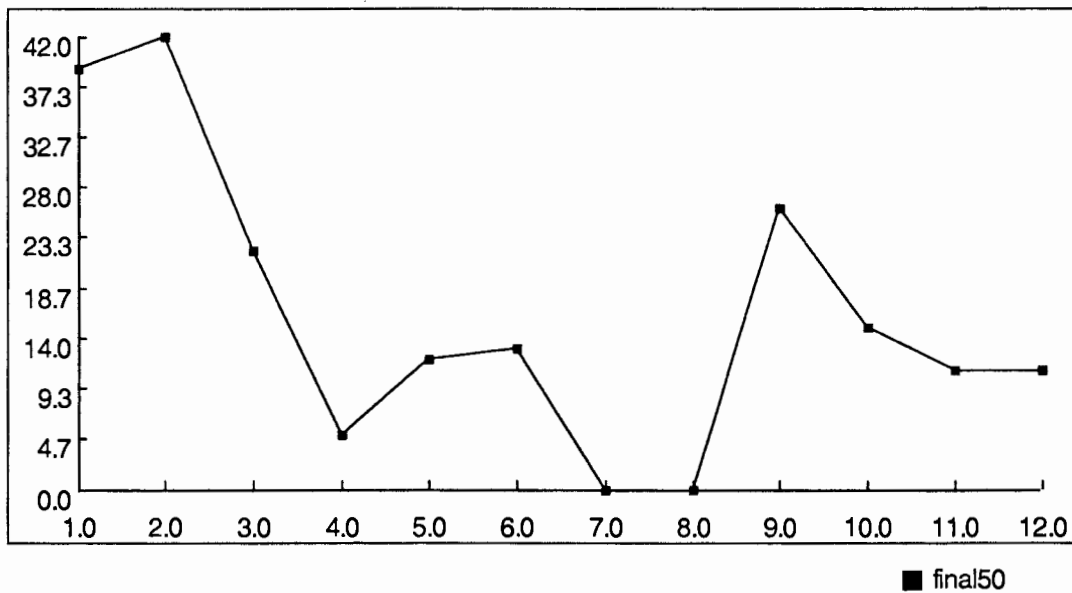
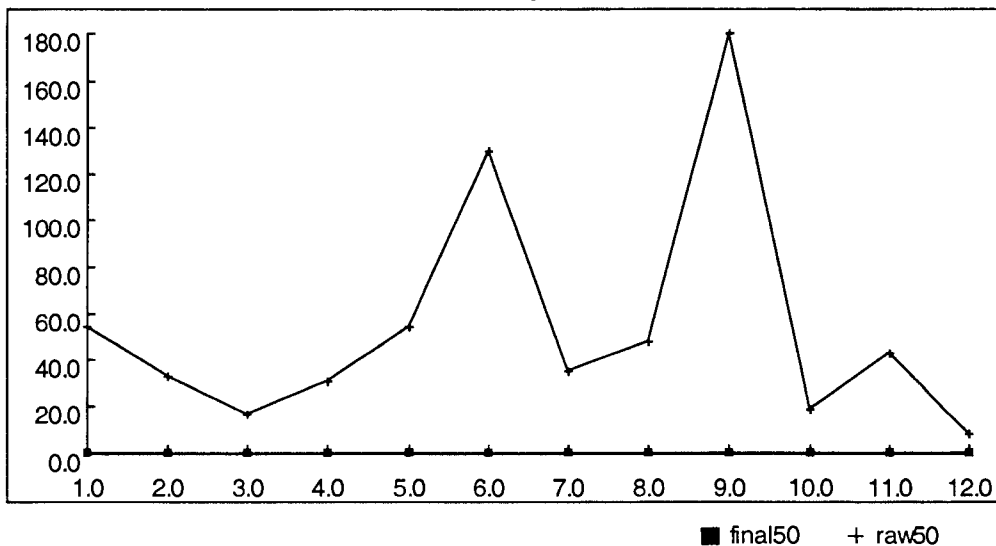

FIGURE 4-3

RAW50 and FINAL50  
Pu-238 concentration (nCi/L).  
JAN-2002 through DEC-2002



FINAL50  
Pu-238 concentration (pCi/L).  
JAN-2002 through DEC-2002

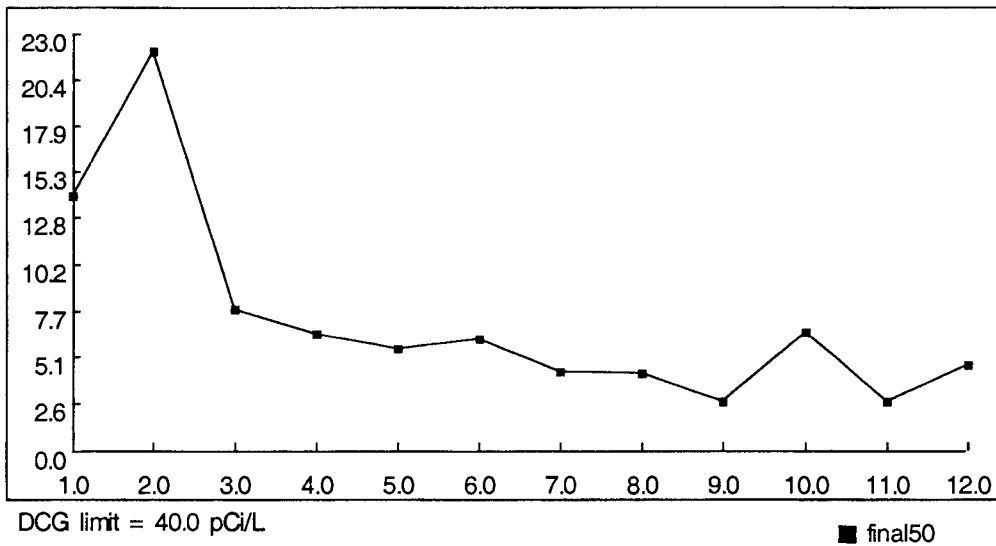
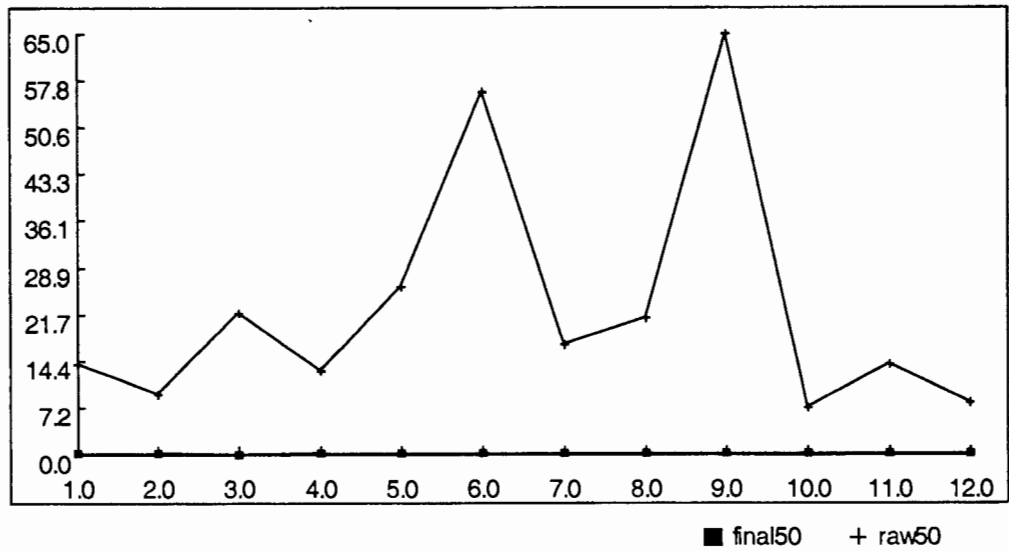

FIGURE 4-4

RAW50 and FINAL50  
Pu-239 concentration (nCi/L).  
JAN-2002 through DEC-2002



FINAL50  
Pu-239 concentration (pCi/L).  
JAN-2002 through DEC-2002

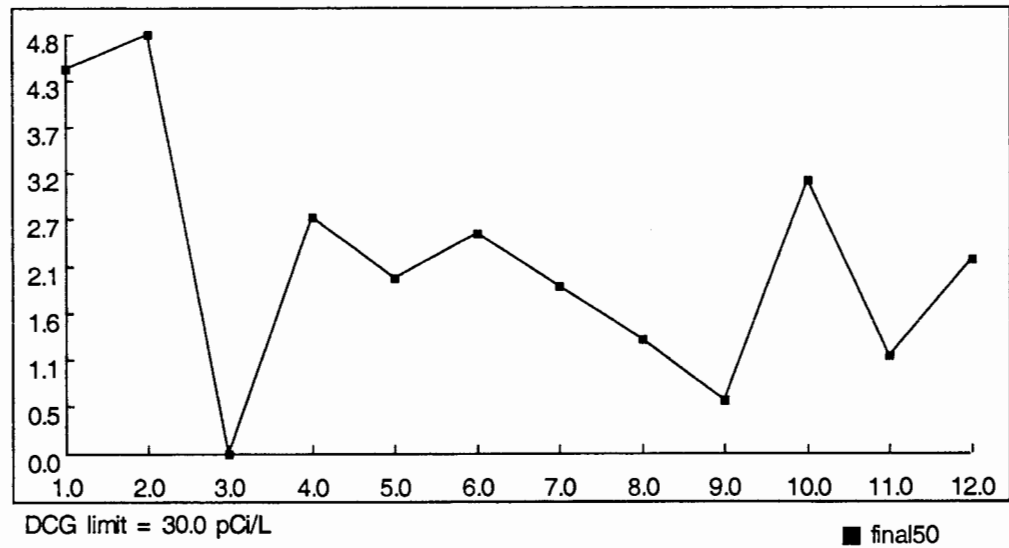
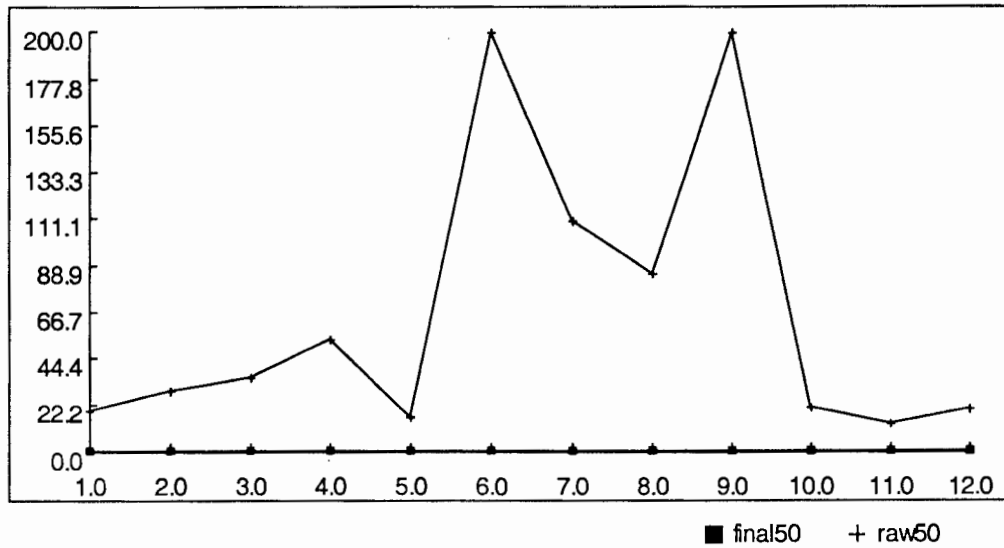

FIGURE 4-5

RAW50 and FINAL50  
Am-241 concentration (nCi/L).  
JAN-2002 through DEC-2002



FINAL50  
Am-241 concentration (pCi/L).  
JAN-2002 through DEC-2002

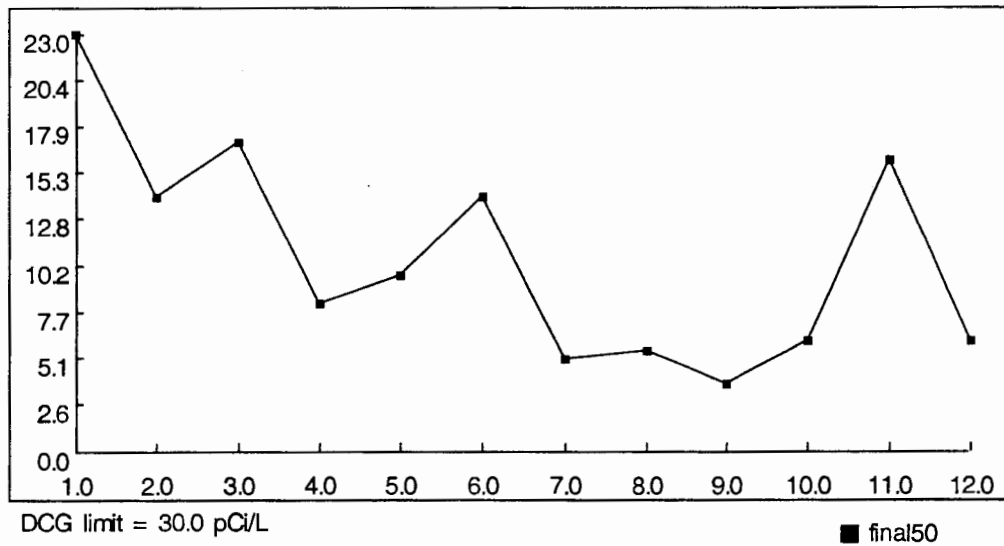
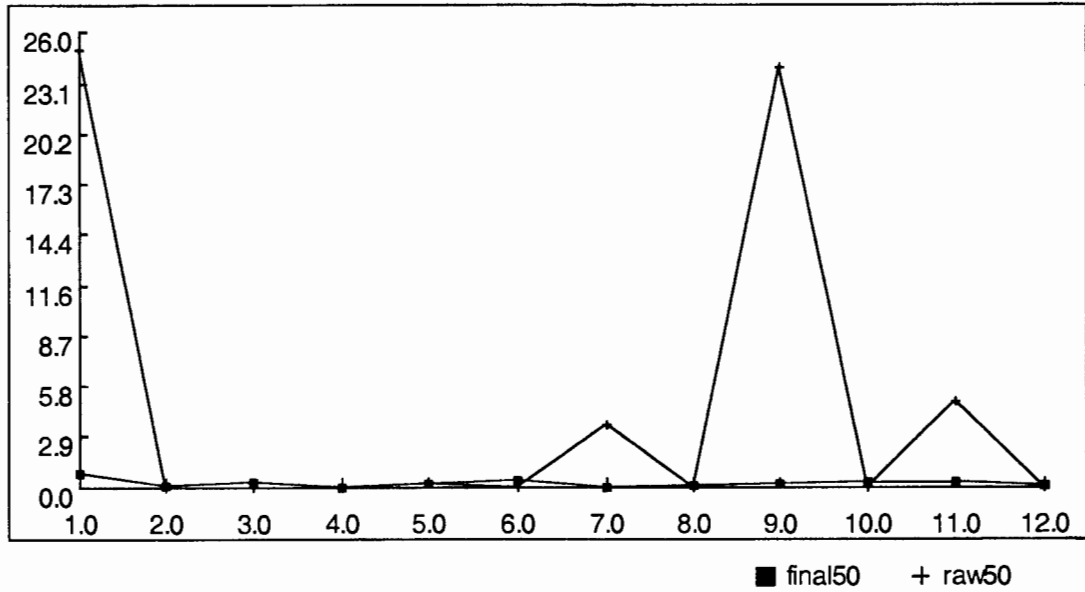

FIGURE 4-6

RAW50 and FINAL50  
BETA concentration (nCi/L).  
JAN-2002 through DEC-2002



FINAL50  
BETA concentration (pCi/L).  
JAN-2002 through DEC-2002

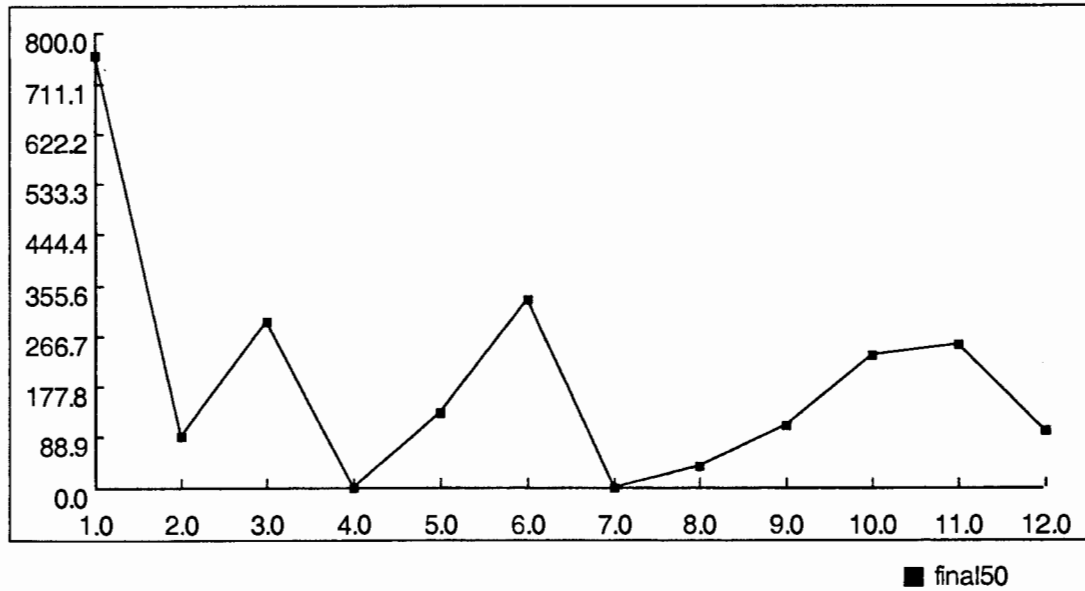
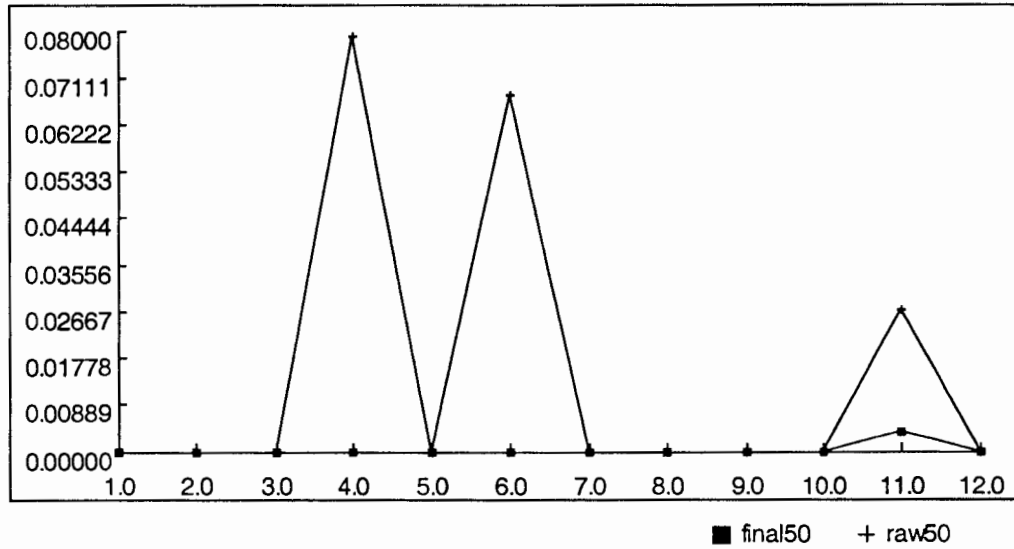

FIGURE 4-7

RAW50 and FINAL50  
Sr-90 concentration (nCi/L).  
JAN-2002 through DEC-2002



FINAL50  
Sr-90 concentration (pCi/L).  
JAN-2002 through DEC-2002

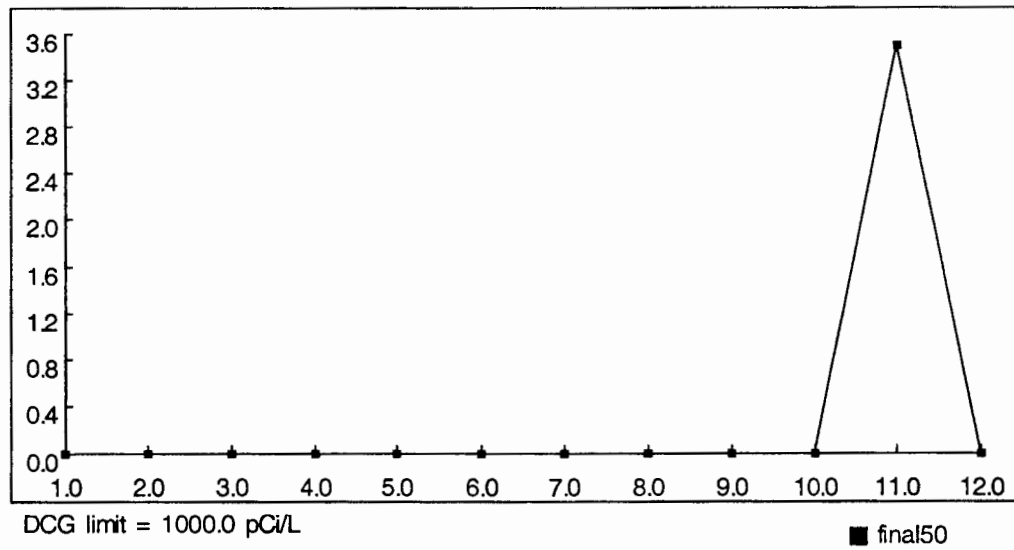
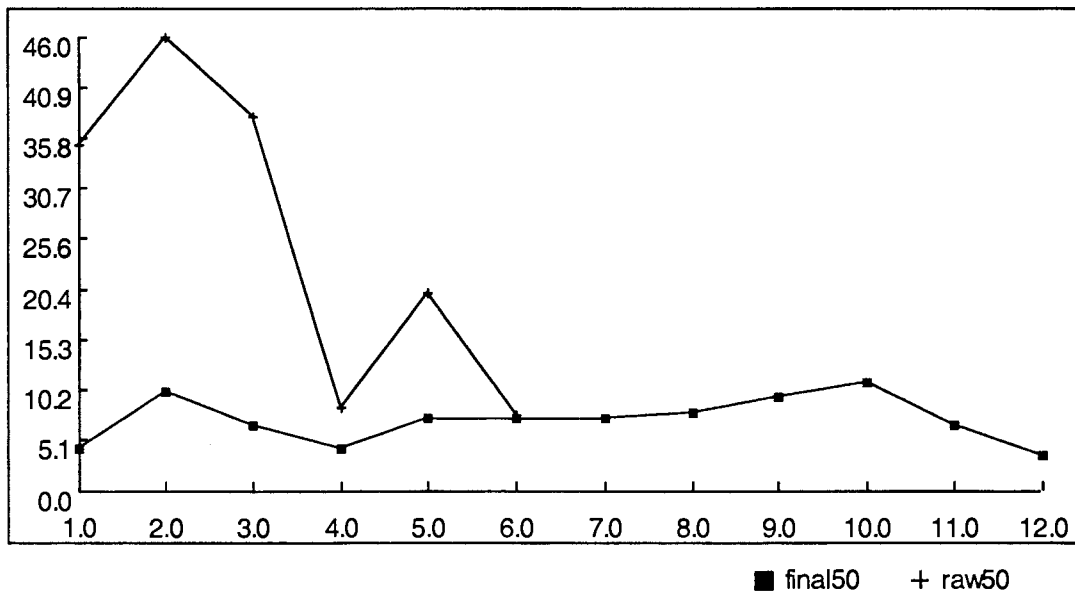

FIGURE 4-8

RAW50 and FINAL50  
TRITIUM concentration (nCi/L).  
JAN-2002 through DEC-2002



RAW50 and FINAL50  
Sr-89 concentration (nCi/L).  
JAN-2002 through DEC-2002

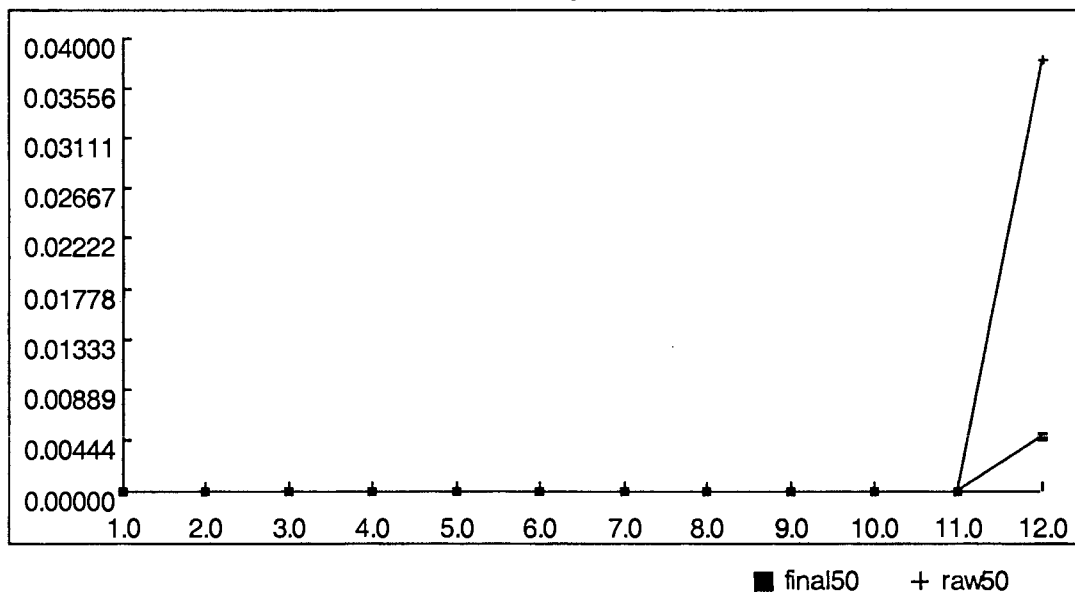

TABLE 4-6

## TA-50 RLWTF

TA-50-1-116, Vacuum Filter Drums Shipped For Disposal

01-JAN-2002 through 31-DEC-2002

MONTH	NO of DRUMS	TOTAL VOLUME (Liters)	GROSS WEIGHT (KG)	U-235 (Curies)	PU-238 (Curies)	PU-239 (Curies)	AM-241 (Curies)
JAN-2002	0	0	0	0	0	0	0
FEB-2002	0	0	0	0	0	0	0
MAR-2002	84	17472.0	15724.09	7.588e-6 +/- 4.036e-6	68.6e-3 +/- 8.44e-3	17.577e-3 +/- 10.435e-3	18.03e-3 +/- 1.806e-3
APR-2002	0	0	0	0	0	0	0
MAY-2002	24	4992.0	4382.73	936.0e-9 +/- 149.0e-9	23.5e-3 +/- 2.3e-3	11.48e-3 +/- 1.032e-3	6.39e-3 +/- 0.631e-3
JUN-2002	48	9984.0	8868.18	2.864e-6 +/- 0.36e-6	48.79e-3 +/- 4.73e-3	16.28e-3 +/- 2.211e-3	17.13e-3 +/- 1.666e-3
JUL-2002	0	0	0	0	0	0	0
AUG-2002	50	10400.0	9370.0	3.152e-6 +/- 0.528e-6	48.9e-3 +/- 4.74e-3	13.05e-3 +/- 1.887e-3	23.18e-3 +/- 2.167e-3
SEP-2002	0	0	0	0	0	0	0
OCT-2002	0	0	0	0	0	0	0
NOV-2002	0	0	0	0	0	0	0
DEC-2002	45	9360.0	8743.18	2.32e-6 +/- 0.713e-6	41.8e-3 +/- 12.39e-3	8.29e-3 +/- 1.343e-3	27.2e-3 +/- 3.235e-3
TOTAL	251	52208.0	47088.18	16.86e-6 +/- 5.786e-6	231.59e-3 +/- 32.6e-3	66.677e-3 +/- 16.908e-3	91.93e-3 +/- 9.505e-3

Issued 31 Mar 2003 3:04:07 p.m.



### 5. Non-Radiological Nature of the CY 2002 TA-50 RLWTF Influent and Effluent Waters and Process Waste Sludge

In addition to radionuclides, the influent wastewater to the TA-50 RLWTF also includes many other inorganic and organic contaminants that require treatment prior to discharge via the NPDES permitted outfall to the environment. Twenty-one (21) parameters in the effluent from the RLWTF are regulated by the National Pollutant Discharge Elimination System (NPDES) in compliance with the Federal Clean Water Act. LANL also has a voluntary commitment with the New Mexico Environment Department (NMED) to not discharge effluent from the TA-50 RLWTF that exceeds groundwater standards set by the New Mexico Water Quality Control Commission (NMWQCC) for three (3) water quality parameters: fluoride, nitrate-nitrogen and total dissolved solids (TDS). Table 5-1 identifies these 24 discharge parameters and also indicates the frequency of sampling required for each parameter.

Table 5-1 NPDES and NMED Discharge Parameters

NPDES (21 parameters)			NMED (3 parameters)
pH <sup>1</sup>	Copper <sup>1</sup>	Selenium <sup>3</sup>	Fluoride <sup>5</sup>
Aluminum <sup>3</sup>	Iron <sup>1</sup>	Zinc <sup>1</sup>	Nitrate Nitrogen <sup>5</sup>
Arsenic <sup>3</sup>	Lead <sup>1</sup>	Chemical Oxygen Demand <sup>1</sup>	Total Dissolved Solids <sup>5</sup>
Boron <sup>3</sup>	Mercury <sup>1</sup>	Total Suspended Solids <sup>1</sup>	
Cadmium <sup>1</sup>	Nickel <sup>2</sup>	Total Toxic Organics <sup>2</sup>	
Chromium <sup>1</sup>	Perchlorate <sup>3</sup>	Tritium (accelerator produced) <sup>3</sup>	
Cobalt <sup>3</sup>	Radium-226 + Radium-228 <sup>3</sup>	Flow <sup>4</sup>	

<sup>1</sup> weekly grab sample

<sup>2</sup> monthly grab sample

<sup>3</sup> yearly grab sample

<sup>4</sup> continuous record

<sup>5</sup> each discharge

The quantitative limits for the twenty-four (24) NPDES and three (3) NMED discharge parameters which pertain to the RLWTF effluent are given in Table 5-2.

The TA-50 RLWTF effluent, for the 3<sup>rd</sup> consecutive year, was in compliance with all twenty-one (21) NPDES water quality parameters during calendar year 2002.

Additionally, concentrations of fluoride, nitrate and TDS in the groundwater influenced by the RLWTF effluent were below NMED standards during calendar year 2002. One (1) weekly composite sample of RLWTF effluent, though, slightly exceeded the NMED groundwater standard for TDS of 1,000 mg/L (sample was 1,030 mg/L). Process controls have been implemented to ensure that the voluntary commitment is not exceeded again.

Table 5-2 Discharge Limits for NPDES and NMED Parameters in the RLWTF Effluent

<b>NPDES Parameters</b>	<b>Monthly Average (mg/L)</b>	<b>Daily Max (mg/L)</b>
Flow	Report	Report
pH	6 -9 su	6 -9 su
Chemical Oxygen Demand	125	125
Total Suspended Solids	30	45
Total Cadmium	0.05	0.05
Total Chromium	1.34	2.68
Total Copper	1.393	1.393
Total Iron	-----	-----
Total Lead	0.423	0.524
Total Mercury	0.00077	0.00077
Total Zinc	4.37	8.75
Total Toxic Organics	1.0	1.0
Total Arsenic	0.368	0.368
Total Aluminum	5.0	5.0
Total Boron	5.0	5.0
Total Cobalt	1.0	1.0
Total Selenium	0.005	0.005
Total Vanadium	0.1	0.1
Radium 226 + Radium 228	30 pCi/L	30 pCi/L
Tritium (when accelerator produced)	20,000 pCi/L	20,000 pCi/L
Total Nickel	Report	Report
Perchlorate	Report	Report
<b>NMED Parameters</b>	<b>Per Discharge (mg/L)</b>	
Fluoride	1.6	
Nitrate-nitrogen	10.0	
Total Dissolved Solids	1,000	

Table 5-3 shows the flow-weighted concentrations for CY 2002 of the TA-50 RLWTF effluent in comparison to the NPDES and NMED standards. The table indicates that the RLWTF effluent is well below the discharge standards on all parameters. It is noted in Table 5-3 that the cadmium concentration in the final effluent during CY 2002 was less than the detection limit (LDL) of the analytical procedure. The LDL for cadmium is 0.003 mg/L. Also, the selenium concentration in the final effluent during CY 2002 was below the LDL of 0.001 mg/L.

The next table, Table 5-4, is the CY 2002 mineral summary for the TA-50 RLWTF. This information is a compilation of analytical information obtained from analyses performed on flow weighted monthly composite samples of both influent and effluent waters. Appendix D is the TA-50 RLWTF monthly mineral summaries during CY 2002.

TABLE 5-3

**TA-50 RLWTF EFFLUENT  
COMPARED TO NPDES & NMED STANDARDS**

JAN, 2002 through DEC, 2002

Regulator	Regulated Parameter	Standard (mg/L)	FINAL Avg. (mg/L)
NMED	FLUORIDE	1.6	0.461
NMED	NITRATE-N	10.0	0.429
NMED	TDS	1,000.0	280.027
NPDES	ALUMINUM	5.0	0.03395
NPDES	ARSENIC	0.368	0.00090
NPDES	BORON	5.0	0.30514
NPDES	CADMIUM	0.05	Idl
NPDES	COBALT	1.0	0.00028
NPDES	COD	125.0	15.89623
NPDES	COPPER	1.393	0.04276
NPDES	LEAD	0.423	0.00068
NPDES	MERCURY	7.7e-4	0.00007
NPDES	RADIUM*	30.0*	3.88540*
NPDES	SELENIUM	0.005	Idl
NPDES	TOTAL_CHROMIUM	1.34	0.00268
NPDES	TOXIC_ORGANICS	1.0	0.00317
NPDES	TSS	30.0	1.76578
NPDES	VANADIUM	0.1	0.00439
NPDES	ZINC	4.37	0.04861
NPDES	pH	6.0 - 9.0	7.85133
NPDES	TRITIUM*	20,000*	7,173.65*
NPDES	IRON	Report Only	0.03193
NPDES	NICKEL	Report Only	0.00841
NPDES	PERCHLORATE	Report Only	0.01588

FINAL Avg. = Flow-weighted average concentration in effluent.

\* Values for radioactive species reported as PicoCuries/Liter.

TABLE 5-4

TA-50 RLWTF  
MINERAL SUMMARY

JAN, 2002 through DEC, 2002

	RAW Average	Maximum	Minimum	Number of Samples	Total (KG)	FINAL Average	Maximum	Minimum	Number of Samples	Total (KG)
ALKALINITY-MO*	56.982	85.8	40.7	12.0	682.988	211.368	470.0	47.4	12.0	2327.206
ALKALINITY-P*	LDL*	LDL*	LDL*	12.0		LDL*	LDL*	LDL*	12.0	
ALUMINUM	0.948	2.9	0.14	12.0	11.362	0.034	0.18	LDL*	12.0	0.374
AMMONIA-N	4.917	14.0	1.6	12.0	58.94	5.642	10.8	2.81	12.0	62.119
ANTIMONY	0.008	0.014	0.002	6.0	0.101	0.007	0.018	0.001	6.0	0.081
ARSENIC	9.856e-4	0.017	LDL*	12.0	0.012	8.955e-4	0.015	LDL*	12.0	0.01
BARIUM	0.036	0.08	0.01	12.0	0.437	2.642e-4	0.002	LDL*	12.0	0.003
BERYLLIUM	0.001	0.005	LDL*	12.0	0.013	5.255e-5	LDL*	LDL*	12.0	5.786e-4
BORON	0.404	2.91	0.045	12.0	4.848	0.305	3.94	LDL*	12.0	3.36
CADMIUM	0.003	0.008	LDL*	12.0	0.037	LDL*	LDL*	LDL*	12.0	
CALCIUM	12.286	17.0	9.82	12.0	147.264	3.532	10.2	0.75	12.0	38.886
CHLORIDE	24.952	57.0	17.0	12.0	299.082	24.838	65.0	3.87	12.0	273.467
COBALT	0.001	0.009	LDL*	12.0	0.015	2.776e-4	0.001	LDL*	12.0	0.003
COD	90.298	270.0	42.0	12.0	1082.318	15.896	56.0	LDL*	12.0	175.021
CONDUCTIVITY*	300.873	410.0	193.0	12.0		630.256	1360.0	134.0	12.0	
COPPER	0.516	1.73	0.152	12.0	6.183	0.043	0.076	LDL*	12.0	0.471
CYANIDE	0.013	0.043	LDL*	12.0	0.161	0.012	0.06	LDL*	12.0	0.127
FLUORIDE	0.676	1.1	0.25	12.0	8.108	0.461	1.04	0.03	12.0	5.073
HARDNESS*	47.265	79.257	36.998	12.0	566.525	10.237	38.235	1.972	12.0	112.715
IRON	2.097	5.3	0.927	12.0	25.14	0.032	0.08	LDL*	12.0	0.352
LEAD	0.107	0.31	0.045	12.0	1.281	6.798e-4	0.008	LDL*	12.0	0.007
MAGNESIUM	4.028	11.0	3.0	12.0	48.278	0.344	3.1	LDL*	12.0	3.792
MERCURY	0.007	0.025	0.002	12.0	0.08	7.354e-5	3.1e-4	LDL*	12.0	8.097e-4
NICKEL	0.232	1.1	0.053	12.0	2.775	0.008	0.02	LDL*	12.0	0.093
NITRATE-N	5.435	18.0	2.55	12.0	65.144	0.429	1.25	0.06	12.0	4.721
NITRITE-N	0.331	0.55	0.012	10.0	3.967	1.143	2.93	0.04	10.0	12.589
PERCHLORATE	0.203	1.09	0.034	12.0	2.432	0.016	0.11	LDL*	12.0	0.175
PHOSPHORUS	3.883	8.1	0.042	12.0	46.543	0.25	1.02	0.02	12.0	2.758
POTASSIUM	5.745	12.0	3.5	12.0	68.861	8.726	30.8	1.7	12.0	96.079
SELENIUM	0.025	0.197	LDL*	12.0	0.3	LDL*	LDL*	LDL*	12.0	
SILICON	36.465	65.0	11.8	12.0	437.067	11.443	24.8	1.06	12.0	125.993
SILVER	0.041	0.105	LDL*	12.0	0.492	0.007	0.086	LDL*	12.0	0.082
SODIUM	32.509	55.0	20.0	12.0	389.658	131.912	311.0	21.0	12.0	1452.376
SULFATE	25.169	56.0	12.0	12.0	301.673	69.525	149.0	15.0	12.0	765.485
TDS	165.448	290.0	LDL*	12.0	1983.07	280.027	750.0	LDL*	12.0	3083.155
TDS-E	149.558	247.0	107.0	3.0	1792.816	381.762	510.0	250.0	3.0	4203.275
THALLIUM	4.94e-5	3.3e-4	LDL*	6.0	5.922e-4	4.083e-4	0.002	LDL*	6.0	0.004
THORIUM	3.873e-13	1.1e-12	LDL*	8.0	4.642e-12	4.953e-15	4.0e-14	LDL*	5.0	5.453e-14
TKN	7.381	16.7	3.46	12.0	88.47	5.796	12.6	2.23	12.0	63.814
TOTAL CATIONS*	2.925	3.94	2.05	12.0		6.653	14.3	1.33	12.0	
TOTAL CHROMIUM	0.054	0.14	0.02	12.0	0.645	0.003	0.014	LDL*	12.0	0.03
TOXIC ORGANICS	LDL*	LDL*	LDL*	0.0		0.003	0.006	7.0e-4	12.0	0.035
TSS	43.056	210.0	LDL*	12.0	516.073	1.766	8.8	LDL*	12.0	19.442
URANIUM	0.256	1.04	0.068	11.0	3.07	5.055e-4	0.005	LDL*	11.0	0.006
VANADIUM	0.015	0.03	LDL*	12.0	0.183	0.004	0.013	LDL*	12.0	0.048
ZINC	0.431	3.28	0.1	12.0	5.172	0.049	0.465	LDL*	12.0	0.535
pH	6.816	7.34	6.01	12.0		7.851	8.26	7.37	12.0	

Volume of Flow: Influent = 11,986,052.0 liters Final = 11,010,203.0 liters

\*Alkalinities and hardness as mg CaCO<sub>3</sub>. \*Conductivity as uS/cm. \*Total Cations as meq/l. \*LDL: Less than Detection Limit. Otherwise: mg/l

The following series of eight (8) figures highlight significant information which pertains to the non-radiological nature of the TA-50 RLWTF influent and effluent.

The upper graph in Figure 5-1 shows the silicon, Si, concentration in the raw daily influent water to the RLWTF and the silicon concentration in the effluent from the RLWTF in monthly composite samples during CY 2002. The lower graph in Figure 5-1 shows the total dissolved solids, TDS, concentration in the raw daily influent water to the RLWTF and the TDS concentration in the effluent from the RLWTF in monthly composite samples during CY 2002.

The upper graph in Figure 5-2 shows the potassium concentration in the raw daily influent water to the RLWTF and the potassium concentration in the effluent from the RLWTF in monthly composite samples during CY 2002. The lower graph in Figure 5-2 shows the sodium concentration in the raw daily influent water to the RLWTF and the sodium concentration in the effluent from the RLWTF in monthly composite samples during CY 2002.

The upper graph in Figure 5-3 shows the chemical oxygen demand, COD, concentration in the raw daily influent water to the RLWTF and the COD concentration in the effluent from the RLWTF in monthly composite samples during CY 2002. The lower graph in Figure 5-3 shows the calcium concentration in the raw daily influent water to the RLWTF and the calcium concentration in the effluent from the RLWTF in monthly composite samples during CY 2002.

The upper graph in Figure 5-4 shows the iron concentration in the raw daily influent water to the RLWTF and the iron concentration in the effluent from the RLWTF in monthly composite samples during CY 2002. The lower graph in Figure 5-4 shows more detail on the iron concentration in the CY 2002 effluent.

The upper graph in Figure 5-5 shows the mercury concentration in the raw daily influent water to the RLWTF and the mercury concentration in the effluent from the RLWTF in monthly composite samples during CY 2002. The lower graph in Figure 5-5 shows more detail on the mercury concentration in the CY 2002 effluent.

FIGURE 5-1

RAW50 and FINAL50  
SILICON concentration (mg/L).  
JAN-2002 through DEC-2002

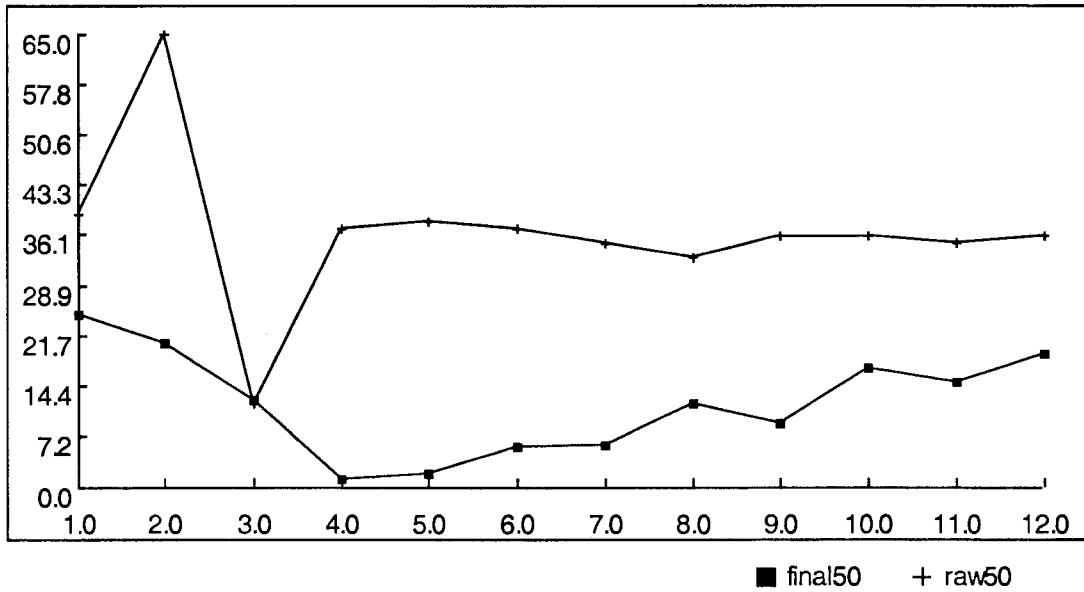

RAW50 and FINAL50  
TDS concentration (mg/L).  
JAN-2002 through DEC-2002

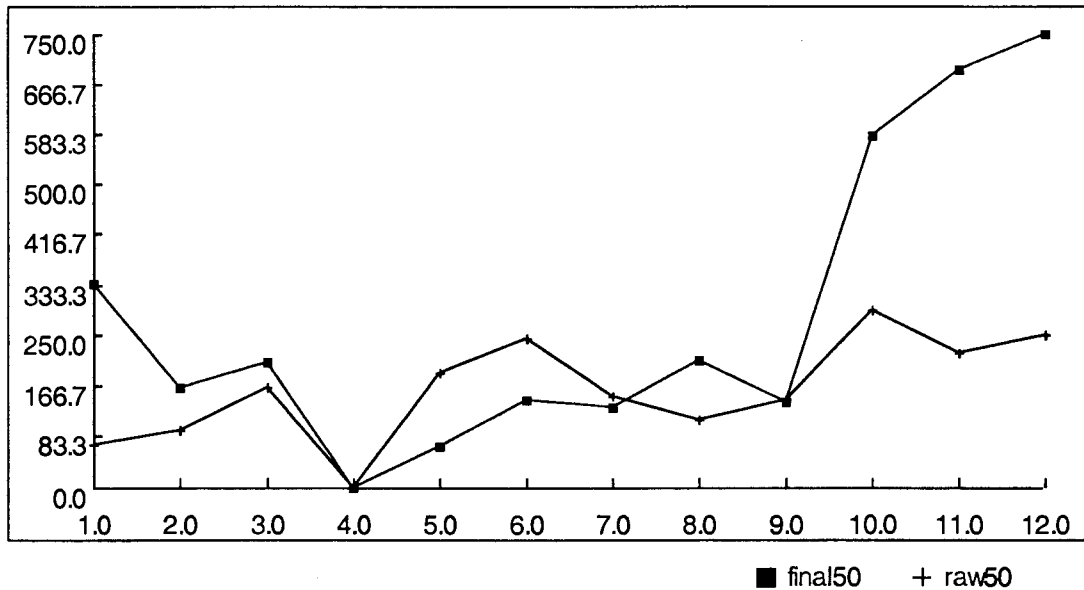
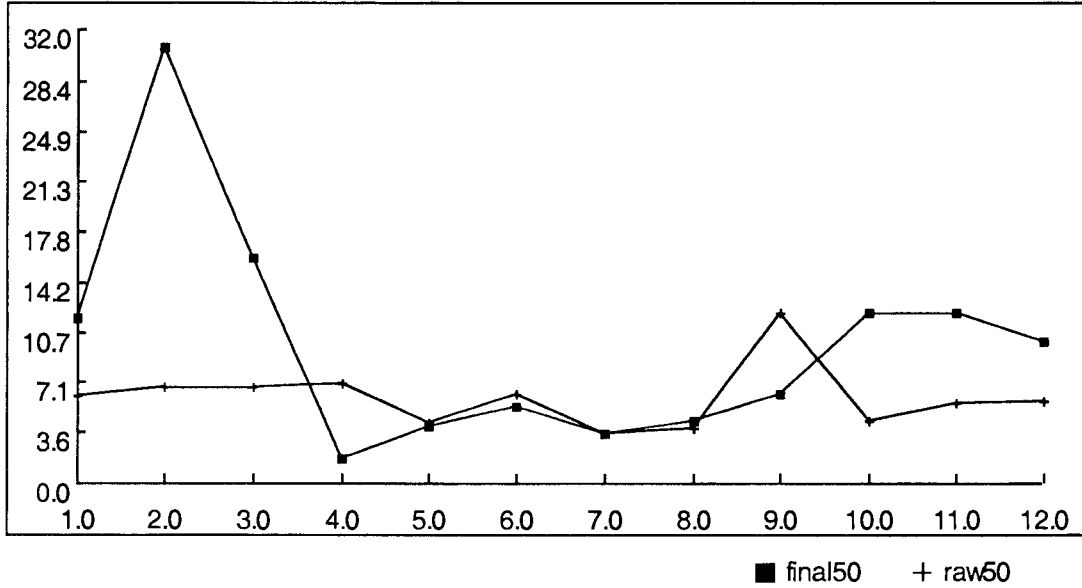

FIGURE 5-2

RAW50 and FINAL50  
POTASSIUM concentration (mg/L).  
JAN-2002 through DEC-2002



RAW50 and FINAL50  
SODIUM concentration (mg/L).  
JAN-2002 through DEC-2002

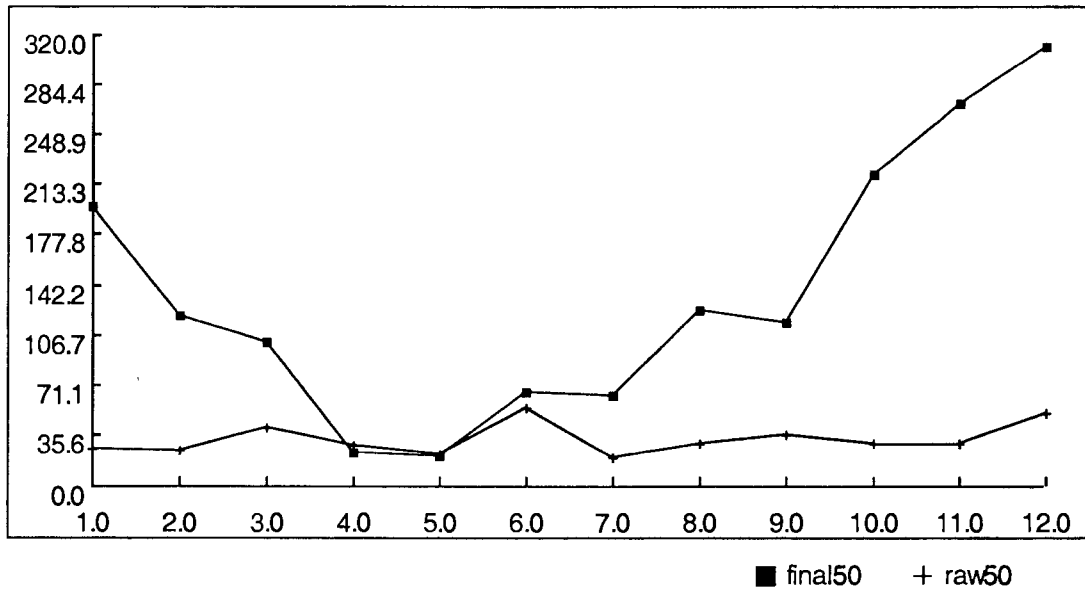
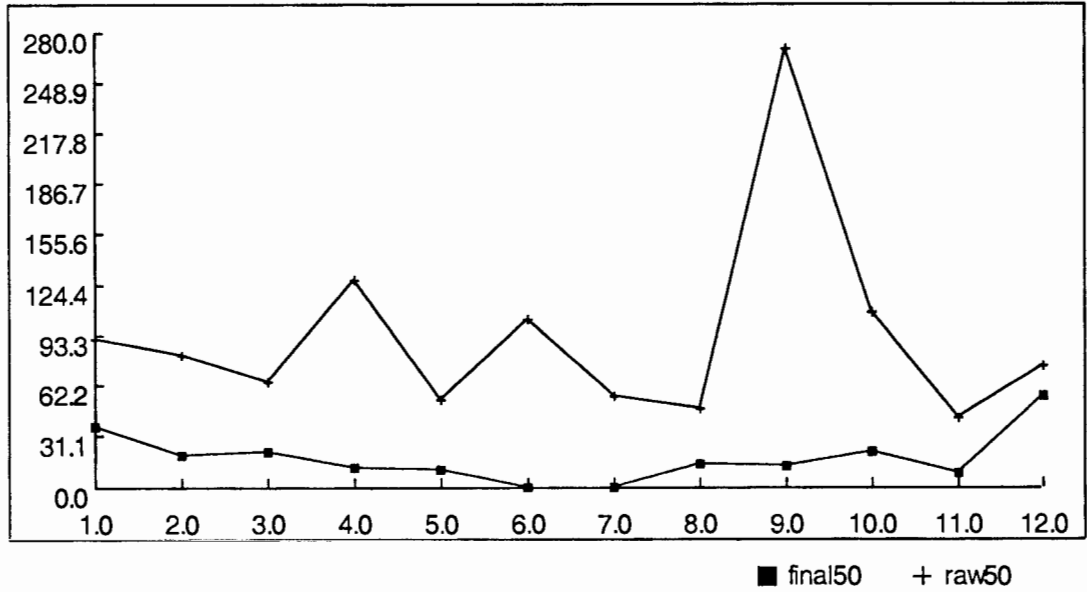



FIGURE 5-3

RAW50 and FINAL50  
COD concentration (mg/L).  
JAN-2002 through DEC-2002



RAW50 and FINAL50  
CALCIUM concentration (mg/L).  
JAN-2002 through DEC-2002

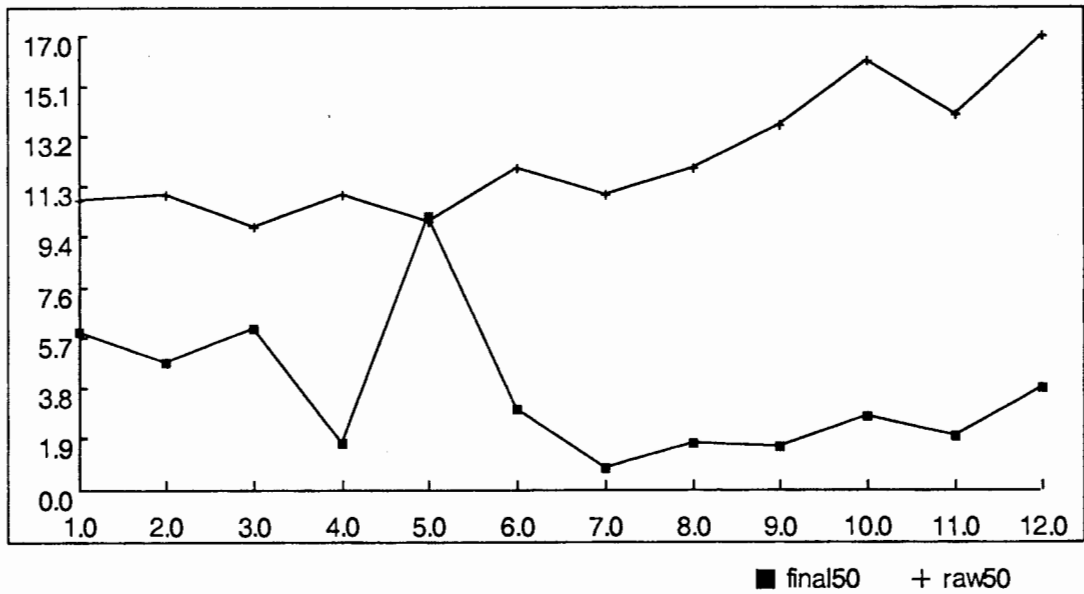
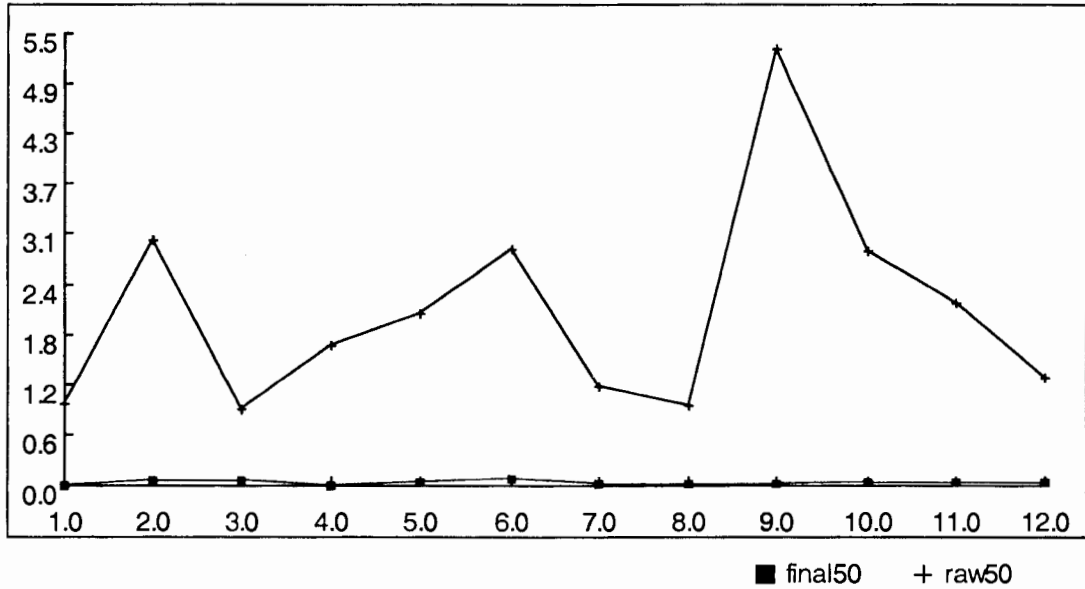

FIGURE 5-4

RAW50 and FINAL50  
IRON concentration (mg/L).  
JAN-2002 through DEC-2002



FINAL50  
IRON concentration (mg/L).  
JAN-2002 through DEC-2002

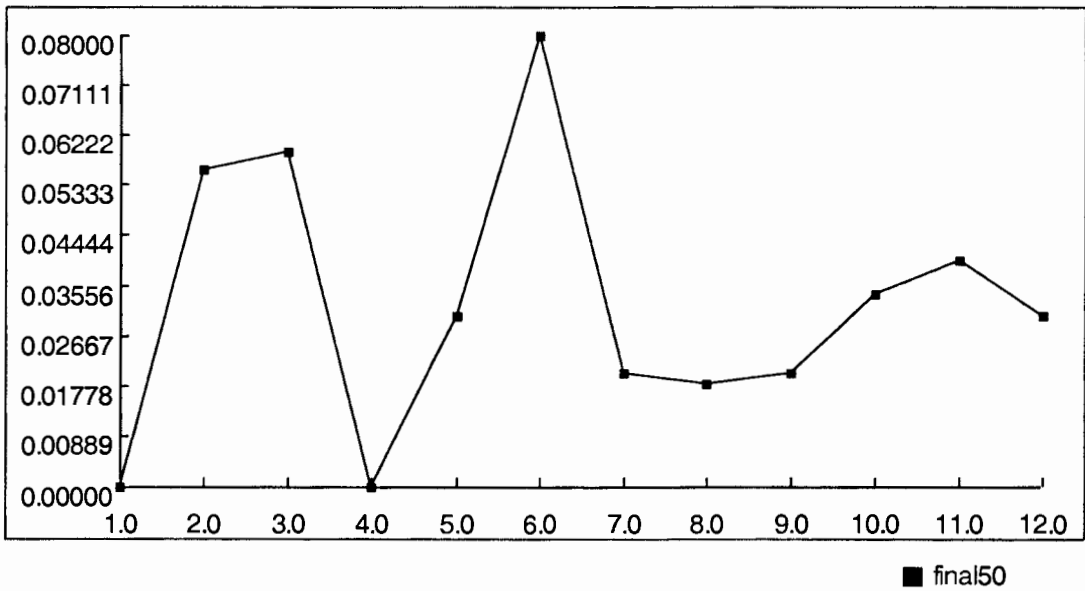
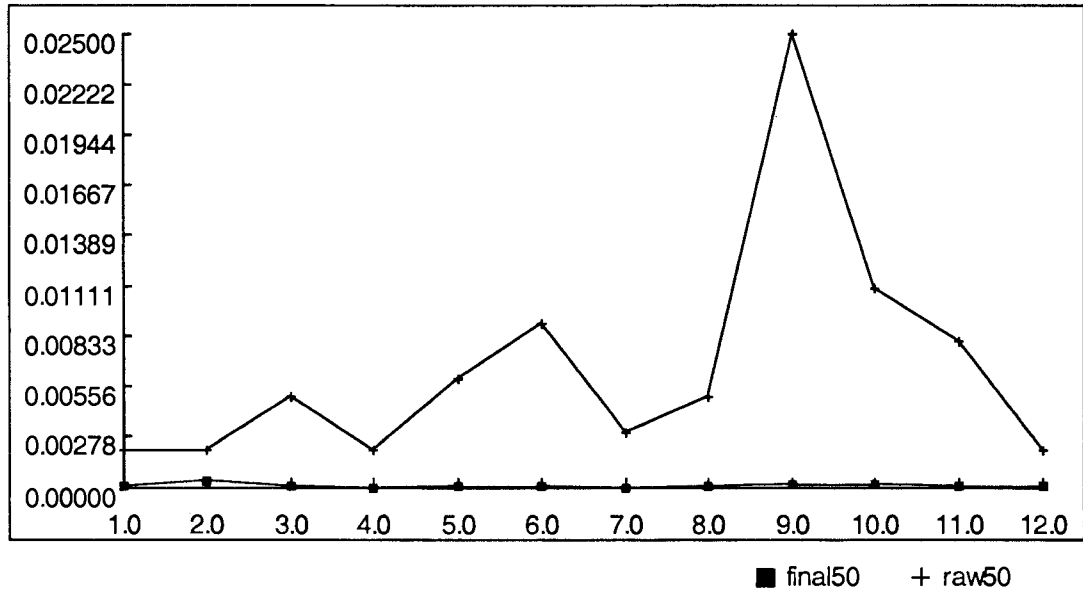
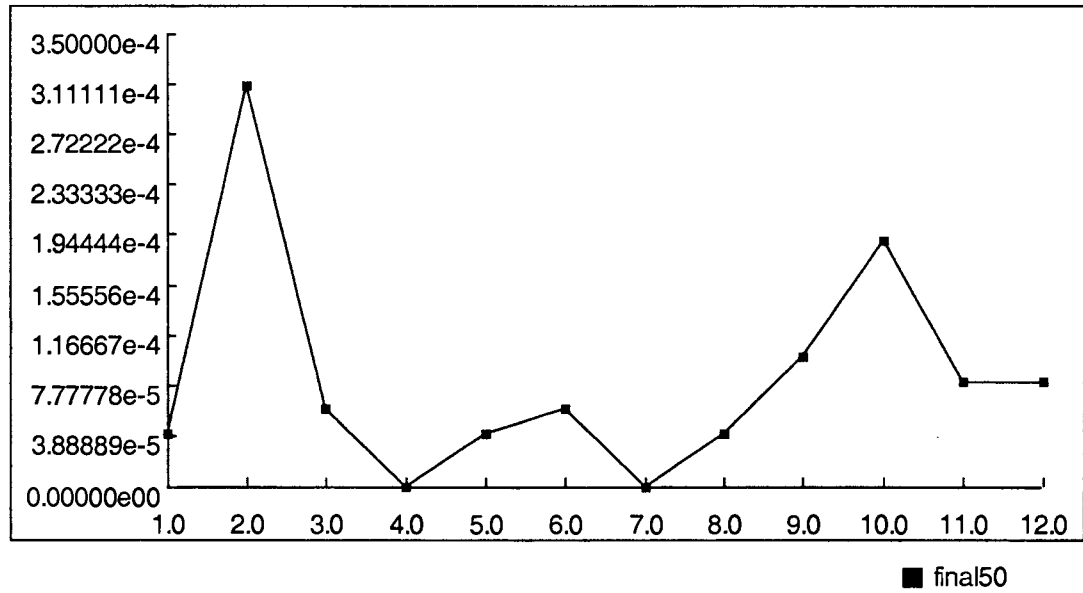

FIGURE 5-5

RAW50 and FINAL50  
MERCURY concentration (mg/L).  
JAN-2002 through DEC-2002



FINAL50  
MERCURY concentration (mg/L).  
JAN-2002 through DEC-2002



The upper graph in Figure 5-6 shows the zinc concentration in the raw daily influent water to the RLWTF and the zinc concentration in the effluent from the RLWTF in monthly composite samples during CY 2002. The lower graph in Figure 5-6 shows the fluoride concentration in the raw daily influent water to the RLWTF and the fluoride concentration in the effluent from the RLWTF in monthly composite samples during CY 2002.

The upper graph in Figure 5-7 shows the perchlorate concentration in the raw daily influent water to the RLWTF and the perchlorate concentration in the effluent from the RLWTF in monthly composite samples during CY 2002. The lower graph in Figure 5-7 shows the methyl orange alkalinity concentration in the raw daily influent water to the RLWTF and the methyl orange alkalinity concentration in the effluent from the RLWTF in monthly composite samples during CY 2002.

The upper graph in Figure 5-8 shows the ammonia-nitrogen concentration in the raw daily influent water to the RLWTF and the ammonia-nitrogen concentration in the effluent from the RLWTF in monthly composite samples during CY 2002. The lower graph in Figure 5-8 shows the nitrate-nitrogen concentration in the raw daily influent water to the RLWTF and the nitrate-nitrogen concentration in the effluent from the RLWTF in monthly composite samples during CY 2002.

FIGURE 5-6

RAW50 and FINAL50  
ZINC concentration (mg/L).  
JAN-2002 through DEC-2002

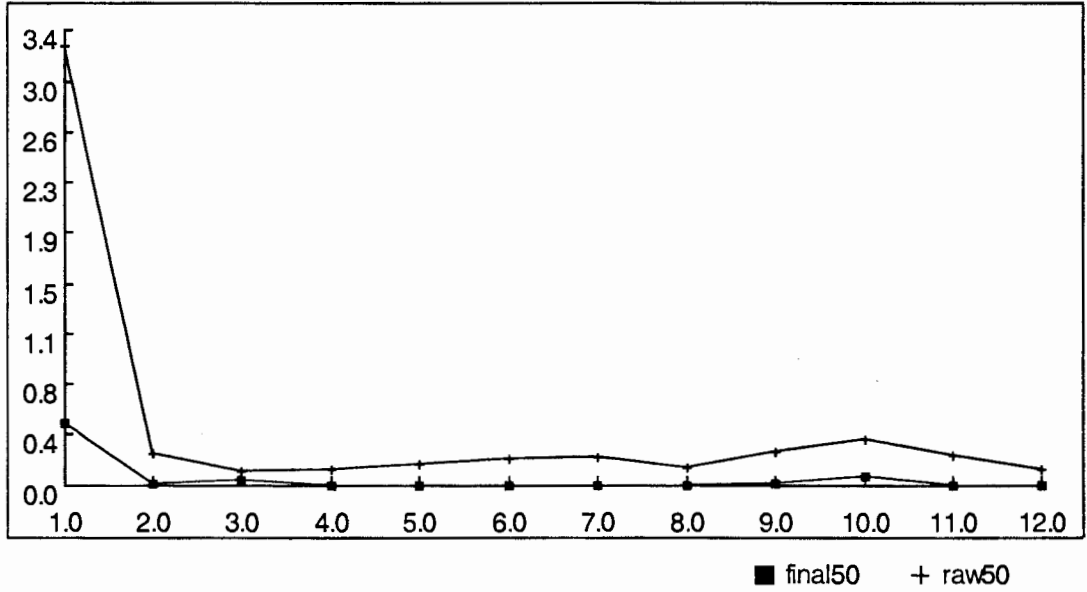

RAW50 and FINAL50  
FLUORIDE concentration (mg/L).  
JAN-2002 through DEC-2002

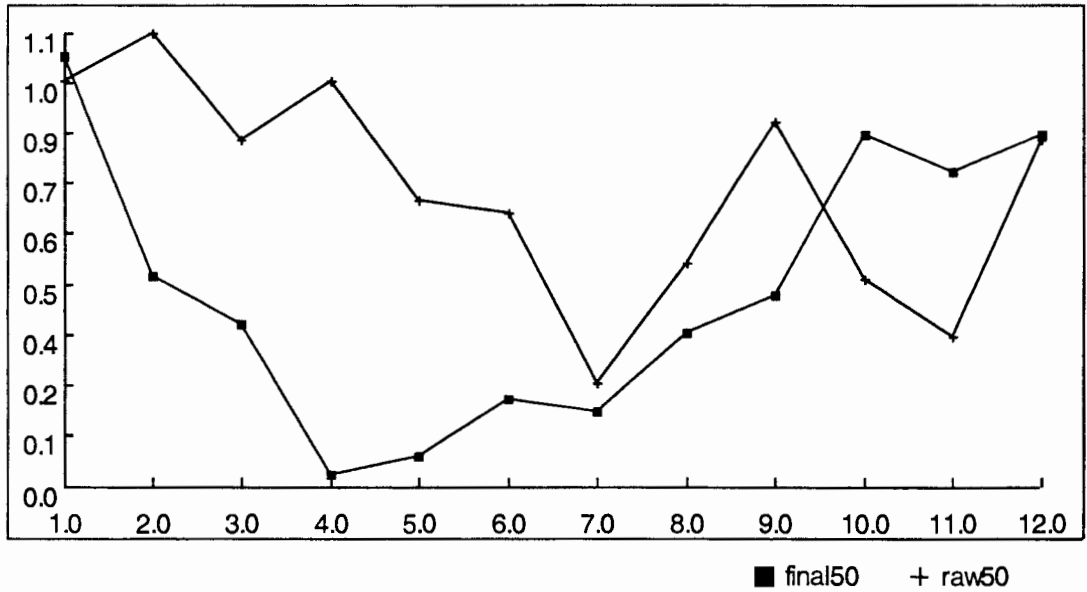
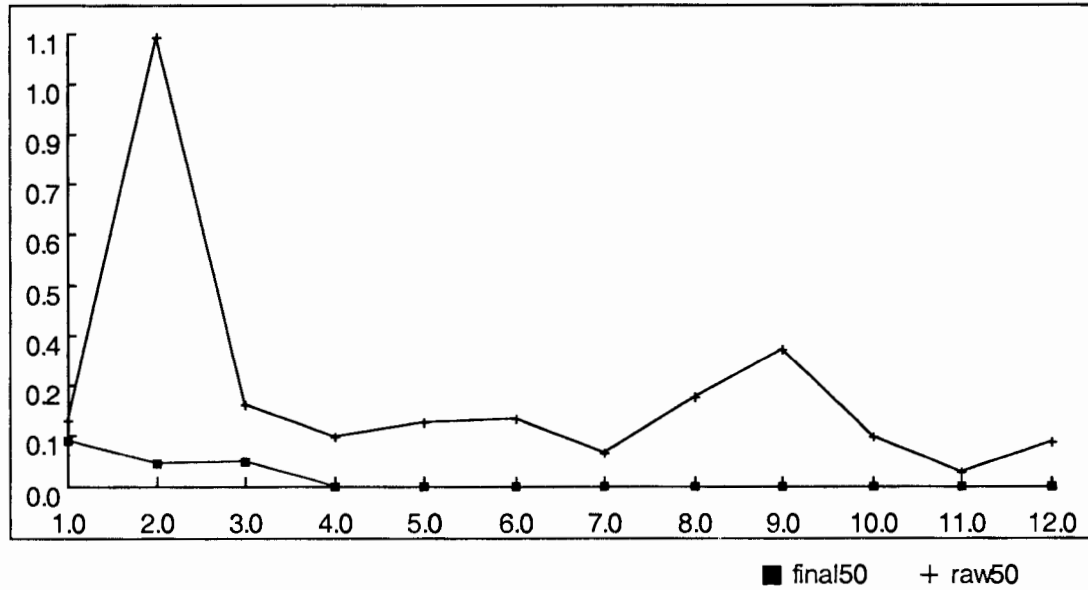

FIGURE 5-7

RAW50 and FINAL50  
PERCHLORATE concentration (mg/L).  
JAN-2002 through DEC-2002



RAW50 and FINAL50  
ALKALINITY-MO concentration (mg/L).  
JAN-2002 through DEC-2002

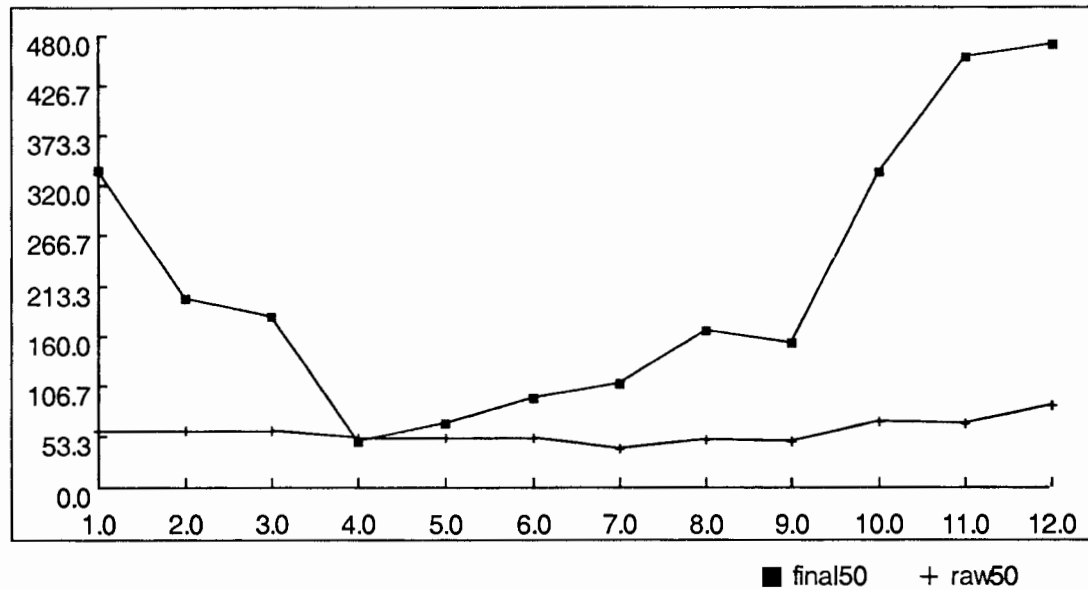
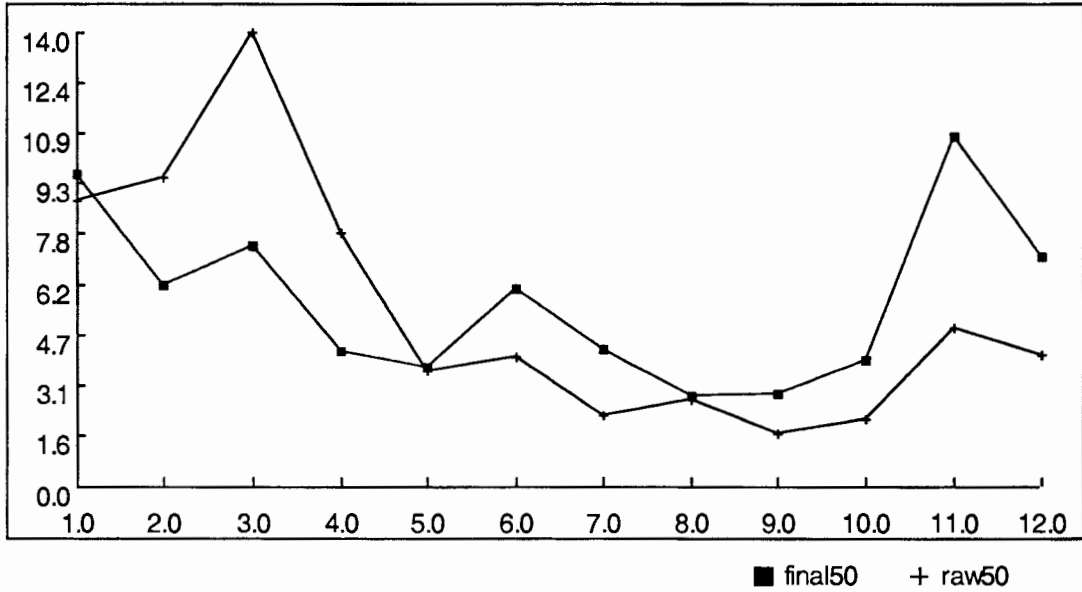
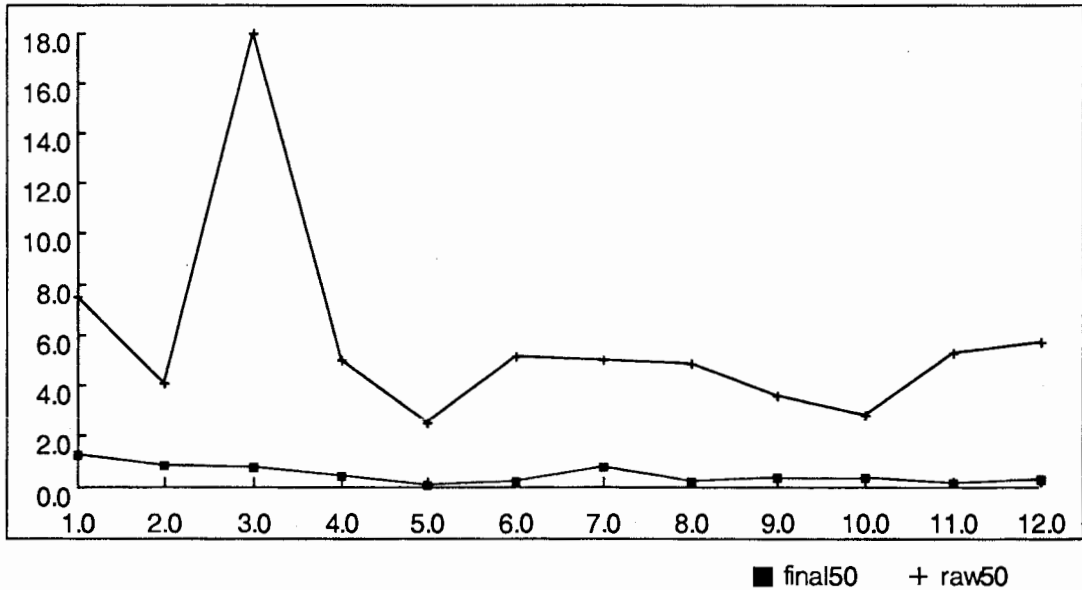

FIGURE 5-8

RAW50 and FINAL50  
AMMONIA-N concentration (mg/L).  
JAN-2002 through DEC-2002



RAW50 and FINAL50  
NITRATE-N concentration (mg/L).  
JAN-2002 through DEC-2002



Volatile organic chemicals (VOC) and semi-volatile organic chemicals (SVOC) are also analyzed for in the TA-50 RLWTF influent wastewaters, treated effluent waters and in the chemical sludge produced by the clarification process. A grab sample of influent water is analyzed for VOC/SVOC on a weekly basis. A monthly grab sample of effluent water is analyzed for VOC/SVOC. Additionally, individual batches of sludge are also analyzed for VOC/SVOC. These analyses are performed according to EPA approved methods 624, 625A and 625B by an external EPA certified laboratory.

Table 5-5 shows the VOC/SVOC detected in the RLWTF influent and the number of weeks in which that chemical was detected during CY 2002. More information pertaining to VOC/SVOC in the RLWTF influent is given in Appendices E, F, G and H.

Table 5-5 VOC/SVOC Detected in Weekly Samples of 2002 RLWTF Influent

<b>VOC (Method 624)</b>	<b>Weeks</b>	<b>Low – High (mg/L)</b>
1,1,1-Trichloroethane	5	0.004 – 0.068
1,1-Dichloroethane	1	0.002
1,2,4-Trimethylbenzene	10	0.0004 – 0.002
2-Butanone	21	0.003 – 0.037
4-Methyl-2-Pentanone	24	0.002 – 0.015
Acetone	46	0.1 – 3.3
Bromodichloromethane	4	0.0002 – 0.0003
Bromoform	3	0.0004 – 0.012
Bromomethane	5	0.0007 – 0.002
Carbon Disulfide	2	0.0003 – 0.0005
Chlorodibromomethane	2	0.00034 – 0.00035
Chloroform	30	0.0004 – 0.086
Chloromethane	18	0.0002 – 0.018
Ethylbenzene	1	0.0004
Iodomethane	3	0.002 – 0.005
Methylene Chloride	26	0.0003 – 0.27
<b>SVOC (Method 625A and 625B)</b>	<b>Weeks</b>	<b>Low – High (mg/L)</b>
Azobenzene	2	0.002 – 0.004
Benzo(A)Pyrene	1	0.003
Benzo(B)Fluoranthene	1	0.003
Benzoic Acid	35	0.003 – 0.14
Benzyl Alcohol	7	0.002 – 0.015
Bis(2-Ethylhexyl)Phthalate	34	0.005 – 0.095
Butylbezyolphthalate	7	0.003 – 0.010
Di-N-Octyl Phthalate	2	0.003 – 0.018
Diethyl Phthalate	1	0.002
Nitrobenzene	1	0.002
Phenol	2	0.002 – 0.017
Pyridine	13	0.003 – 0.042



Table 5-6 summarizes the VOC/SVOC detected in the RLWTF effluent during CY 2002 and the concentration range of these chemicals. The "months" column in Table 5-6 indicates the number of monthly samples in which a particular chemical was detected. For example, the VOC chemical, Chloroform, was detected in very small concentrations in each of the twelve (12) monthly effluent samples. Whereas benzene, another VOC chemical, was detected only in one (1) of the monthly effluent samples.

Table 5-6 VOC/SVOC Detected in Monthly Samples of 2002 RLWTF Effluent

<b>VOC (Method 624)</b>	<b>Months</b>	<b>Low – High (mg/L)</b>
1,1,1-Trichloroethane	1	0.0007
1,4-Dichlorobenzene	2	0.0003
Benzene	1	0.0004
Chloroform	12	0.0005 – 0.0054
Methyl Chloride	1	0.0007
Toluene	2	0.0003
<b>SVOC (Method 625A and 625B)</b>	<b>Months</b>	<b>Low – High (mg/L)</b>
Acenaphthylene	1	0.0003
Anthracene	1	0.0002
Bis(2-Ethylhexyl)Phthalate	6	0.0004 – 1.0026
Diethyl Phthalate	1	0.0016
Fluoranthene	2	0.0002 – 0.0003
Fluorene	1	0.0003
Naphthalene	2	0.0001 – 0.0002
N-Nitrosodimethylamine	1	0.0010
N-Nitrosodi-n-propylamine	1	0.0009
Phenanthrene	1	0.0002
Phenol	1	0.0014
Pyrene	1	0.0002

Table 5-7 summarizes the VOC/SVOC chemicals detected in the RLWTF sludge during CY 2002 and the range of concentrations of these chemicals. Additional information pertaining to VOC/SVOC in the RLWTF sludge is given in Appendices I, J, K and L.

Table 5-7 VOC/SVOC Detected in Samples of 2002 RLWTF Sludge

<b>VOC (Method 624)</b>	<b>Low – High (mg/L)</b>
1,2,4-Trimethylbenzene	0.004 – 0.18
1,2-Dichlorobenzene	0.0007
1,3,5-Trimethylbenzene	0.004 – 0.005
2-Butanone	0.012 – 0.05
4-Methyl-2-Pentanone	0.004 – 0.009
Acetone	0.09 – 0.72
Bromomethane	0.002 – 0.003
Chloroform	0.001 – 0.041
Methylene Chloride	0.001 – 0.096
Styrene	0.001
Toluene	0.0006 – 0.068
Trichlorofluoromethane	0.002
<b>SVOC (Method 625A and 625B)</b>	<b>Low – High (mg/L)</b>
Bis(2-Ethylhexyl)Phthalate	2.5 – 30.0
Di-N-Octyl Phthalate	0.21
Phenol	0.73

## 6. Summary of CY 2002 Operations at the TA-21 RLWTP

The TA-21 Radioactive Liquid Waste Treatment Plant (RLWTP) historically treated radioactive liquid waste from a number of facilities at TA-21. Presently, the TA-21 RLWTP treats limited volumes of radioactive liquid waste generated from tritium research at TA-21 using three (3) treatment processes (clarifier, sand filter and sludge vacuum filtration). The TA-21 plant is physically separated from the radioactive liquid waste collection system, which conveys water to the main TA-50 RLWTF.

During CY 2002, the TA-21 RLWTP received 30,280 liters of influent wastewater. The plant was operated only once during CY 2002, in January, and treated 37,000 liters of radioactive liquid waste at that time. The volumes of received and treated water are not identical due to stored volumes of RLW in the influent tanks at the TA-21 RLWTP. The water treated in CY 2002 is presently in the effluent tanks at the TA-21 RLWTP. Sludge was not treated in the vacuum filter at TA-21 during CY 2002. As a result, no drums of dewatered sludge were generated or shipped to TA-54 for disposal.

Effluent from the TA-21 RLWTP is normally trucked to the TA-50 RLWTF for additional treatment to remove alpha particle radioactivity. During CY 2002 no treated effluent from the TA-21 RLWTP was trucked to the TA-50 RLWTF.

Tables 6-1, 6-2, 6-3 and 6-4 summarize the radiological, mineral, VOC and SVOC constituents in the 37,000 liters of water treated at the TA-21 RLWTP during January 2002. The "Total (Ci)" column in Table 6-1 and the "Total (kg)" column in Table 6-2 display zeroes for each radioisotope and each mineral constituent. This is because the influent flow meters at the TA-21 RLWTP recorded no flow during January 2002. The 37,000 liters of RLW treated in January 2002 came from the TA-21 RLWTP influent holding tanks. The total curies of radioisotopes and the total kilograms of mineral constituents can be determined by multiplying the activities and concentrations of constituents in Tables 6-1 and 6-2 by 37,000 liters.

TABLE 6-1

**TA21 RADIOISOTOPES**  
JAN-2002

	RAW nCi/L	RAW Total (Ci)
ALPHA	45.0	0.0
Am-241	21.0	0.0
BETA	3.7	0.0
Cs-137	LDL*	
Pu-238	2.9	0.0
Pu-239	9.2	0.0
Sr-89	LDL*	
Sr-90	64.0e-3	0.0
TOTAL PLUTONIUM	12.1	0.0
TRITIUM	310.0	0.0
U-234	400.0e-3	0.0
U-235	LDL*	
U-238	LDL*	

Volume of Flow: Influent = 0.0 liters Transferred = 0.0 liters

\*LDL: Less than Detection Limit.

TABLE 6-2

## TA21 MINERALS

JAN-2002

	RAW Concentration	Total (KG)
ALKALINITY-MO	269.0	0.0
ALKALINITY-P	83.8	0.0
ALUMINIUM	0.001	0.0
AMMONIA-N	0.89	0.0
ANTIMONY	0.019	0.0
ARSENIC	LDL*	
BARIUM	0.051	0.0
BERYLLIUM	0.001	0.0
BORON	0.067	0.0
CADMIUM	0.023	0.0
CALCIUM	74.8	0.0
CHLORIDE	61.0	0.0
COBALT	0.005	0.0
COD	42.0	0.0
CONDUCTIVITY	700.0	
COPPER	0.123	0.0
FLUORIDE	1.33	0.0
HARDNESS	204.524	0.0
IRON	28.3	0.0
LEAD	0.043	0.0
MAGNESIUM	4.31	0.0
MERCURY	2.0e-5	0.0
NICKEL	0.101	0.0
NITRATE-N	0.28	0.0
PERCHLORATE	0.001	0.0
POTASSIUM	38.7	0.0
SELENIUM	0.604	0.0
SILICON	28.8	0.0
SILVER	LDL*	
SODIUM	87.2	0.0
SULFATE	102.0	0.0
THALLIUM	7.3e-4	0.0
TOTAL CATIONS	9.93	
TOTAL CHROMIUM	0.039	0.0
URANIUM	0.029	0.0
VANADIUM	0.032	0.0
ZINC	4.98	0.0
pH	10.29	

Volume of Flow: Influent = 0.0 liters Transferred = 0.0 liters

\*Alkalinities and hardness as mg CaCO<sub>3</sub>/l. \*Conductivity as uS/cm. \*Total Cations as req/l. Otherwise: mg/l

\*LDL: Less than Detection Limit.

TABLE 6-3

RADIOACTIVE LIQUID WASTE  
TREATMENT FACILITY

VOC results by species for TA21  
01-JAN-2002 through 31-DEC-2002

Sample Date	Sample Number	Species	Concentration (mg/l)	Uncertainty (mg/l)
09-JAN-2002	DP0102.09	1,2,4-TRIMETHYLBENZENE	3.5e-4	3.5e-5
09-JAN-2002	DP0102.09	1,2-XYLENE	2.5e-4	2.5e-5
09-JAN-2002	DP0102.09	2-BUTANONE	0.002	1.5e-4
09-JAN-2002	DP0102.09	4-METHYL-2-PENTANONE	9.0e-4	9.0e-5
09-JAN-2002	DP0102.09	ACETONE	0.013	0.001

Issued 21 Apr 2003 10:02:30 a.m. Page 1 of 1.

TABLE 6-4

RADIOACTIVE LIQUID WASTE  
TREATMENT FACILITY

SVOC results by species for TA21  
01-JAN-2002 through 31-DEC-2002

Sample Date	Sample Number	Species	Concentration (mg/l)	Uncertainty (mg/l)
09-JAN-2002	DP0102.09	ANILINE	0.002	2.1e-4
09-JAN-2002	DP0102.09	BIS(2-ETHYLHEXYL)PHTHALATE	0.014	0.001

Issued 21 Apr 2003 10:03:56 a.m. Page 1 of 1.

## 7. Summary of CY 2002 Operations at the TA-53 RLWTP

The TA-53 RLWTP treats radioactive liquid waste from accelerator research at the Los Alamos Neutron Science Center. The treatment process includes wastewater storage to allow short-lived radioisotope decay and solar evaporation. Operations at the TA-53 RLWTP started in December 1999.

During CY 2002 the TA-53 RLWTP received 194,068 liters of wastewater from accelerator research at the Los Alamos Neutron Science Center. Additionally during CY 2002, 48,970 liters of wastewater were trucked to the TA-53 RLWTP from the Radiochemistry Facility (TA-48) and the Weapons Engineering Tritium Facility (WETF) at TA-16. These trucked wastewaters met the waste acceptance criteria for the TA-53 RLWTP.

During CY 2002, 244,579 liters of water was pumped from the storage tanks for solar evaporation in the basins at the TA-53 RLWTP.



**Appendix A**

**TA-50 RLWTF Monthly Flow Summary**

## TA50 MONTHLY FLOWS (liters)

JAN-2002 through DEC-2002

	Influent	Treated	Time (hrs)	Rate (liters/min)	Effluent	DP	Misc	Recirc	Sludge
JAN-2002									
Total	868,026	934,569	85.0		952,068	0	0	0	0
Maximum/Day	95,839	113,861	9.0	259.777	146,472				
Minimum/Day	4,004	6,707	3.0	37.261	73,236				
Average/Day	28,001	54,975	5.0	176.095	86,552				
FEB-2002									
Total	787,405	705,477	73.0		578,594	0	0	43,050	0
Maximum/Day	72,565	106,430	11.0	279.842	73,236				
Minimum/Day	5,657	3,795	2.0	31.625	66,548				
Average/Day	28,122	50,391	5.214	157.17	72,324				
MAR-2002									
Total	821,278	694,928	70.0		657,306	0	0	162,895	0
Maximum/Day	94,851	128,033	8.0	304.84	73,236			80,537	
Minimum/Day	4,490	28,769	3.0	95.897	72,630			29,353	
Average/Day	26,493	57,911	5.833	162.546	73,034			54,298	
APR-2002									
Total	826,666	885,505	85.0		731,754	0	106,768	115,522	45,732
Maximum/Day	75,955	101,926	10.0	312.579	146,472		44,100	42,604	25,719
Minimum/Day	13,036	14,974	1.0	64.963	73,236		20,064	13,013	20,013
Average/Day	27,556	55,344	5.312	185.302	104,536		35,589	28,881	22,866
MAY-2002									
Total	1,066,196	1,159,960	125.0		1,020,837	0	0	130,648	0
Maximum/Day	85,134	121,647	10.0	467.462	146,472			63,444	
Minimum/Day	11,269	14,670	4.0	46.747	69,375			24,867	
Average/Day	34,393	57,998	6.25	161.799	78,526			43,549	

## TA50 MONTHLY FLOWS (liters)

JAN-2002 through DEC-2002

	Influent	Treated	Time (hrs)	Rate (liters/min)	Effluent	DP	Misc	Recirc	Sludge
JUN-2002									
Total	1,306,290	1,452,005	137.0		1,165,296	0	0	219,752	0
Maximum/Day	122,518	113,348	11.0	494.561	146,472			90,620	
Minimum/Day	3,176	35,887	2.0	106.105	67,986			34,048	
Average/Day	43,543	76,421	7.211	197.829	77,686			54,938	
JUL-2002									
Total	1,354,195	1,477,205	126.0		1,461,654	0	0	114,799	0
Maximum/Day	82,578	131,893	9.0	480.239	146,472			72,284	
Minimum/Day	11,026	89	2.0	0.371	72,006			7,130	
Average/Day	43,684	70,343	6.0	211.524	85,980			22,960	
AUG-2002									
Total	984,096	1,012,624	75.0		876,390	0	0	16,935	0
Maximum/Day	78,387	102,407	7.0	326.95	145,866				
Minimum/Day	13,528	16,603	2.0	138.358	72,006				
Average/Day	31,745	63,289	4.688	222.572	79,672				
SEP-2002									
Total	727,429	846,239	72.0		873,153	0	0	0	0
Maximum/Day	106,570	117,270	7.0	362.129	73,236				
Minimum/Day	6,381	17,674	1.0	79.317	69,375				
Average/Day	24,248	60,446	5.143	206.776	72,763				
OCT-2002									
Total	906,363	1,032,390	72.0		947,978	0	0	46,348	0
Maximum/Day	93,169	109,756	7.0	525.883	145,412			25,848	
Minimum/Day	3,925	31,122	2.0	88.742	72,630			20,500	
Average/Day	29,238	73,742	5.143	256.027	78,998			23,174	

02072

## TA50 MONTHLY FLOWS (liters)

JAN-2002 through DEC-2002

	Influent	Treated	Time (hrs)	Rate (liters/min)	Effluent	DP	Misc	Recirc	Sludge
NOV-2002									
Total	1,350,067	978,044	76.0		942,700	0	0	78,665	0
Maximum/Day	389,606	129,488	8.0	332.82	150,935			30,304	
Minimum/Day	15,912	14,563	3.0	48.543	64,319			8,312	
Average/Day	45,002	69,860	5.429	214.875	94,270			15,733	
DEC-2002									
Total	988,041	805,970	67.0		802,473	0	27,405	72,913	0
Maximum/Day	187,169	120,229	8.0	333.969	146,472			28,522	
Minimum/Day	11,429	9,576	3.0	26.6	70,719			18,543	
Average/Day	31,872	67,164	5.583	205.278	80,247			24,304	
SUMMARY									
Total	11,986,052	11,984,916	1063.0		11,010,203	0	134,173	1,001,527	45,732
Maximum/Month	1,354,195	1,477,205			1,461,654	0	106,768	219,752	45,732
Minimum/Month	727,429	694,928			578,594		27,405	16,935	45,732
Average/Month	998,838	998,743	88.583	187.91	917,517	0	11,181	83,461	3,811

**Appendix B**  
**TA-50 RLWTF Daily Flow Summary**

TA50 DAILY FLOWS (liters)

JAN-2002

	Influent	Treated	Time (hrs)	Rate (liters/min)	Effluent	DP	Misc	Recirc	Sludge
01-JAN-2002	12,425	0	0.0	0.0	0	0	0	0	0
02-JAN-2002	36,986	43,221	5.0	144.07	73,236	0	0	0	0
03-JAN-2002	33,991	66,317	7.0	157.898	146,472	0	0	0	0
04-JAN-2002	20,005	50,401	5.0	168.003	0	0	0	0	0
05-JAN-2002	13,555	0	0.0	0.0	0	0	0	0	0
06-JAN-2002	13,555	0	0.0	0.0	0	0	0	0	0
07-JAN-2002	44,889	72,706	6.0	201.961	73,236	0	0	0	0
08-JAN-2002	48,659	28,808	4.0	120.033	0	0	0	0	0
09-JAN-2002	31,102	56,828	4.0	236.783	73,236	0	0	0	0
10-JAN-2002	27,509	0	0.0	0.0	73,236	0	0	0	0
11-JAN-2002	21,934	49,663	5.0	165.543	0	0	0	0	0
12-JAN-2002	14,684	0	0.0	0.0	0	0	0	0	0
13-JAN-2002	4,924	0	0.0	0.0	0	0	0	0	0
14-JAN-2002	52,468	77,933	5.0	259.777	73,236	0	0	0	0
15-JAN-2002	22,471	26,397	3.0	146.65	73,236	0	0	0	0
16-JAN-2002	25,934	0	0.0	0.0	0	0	0	0	0
17-JAN-2002	95,839	113,861	9.0	210.854	0	0	0	0	0
18-JAN-2002	7,457	0	0.0	0.0	0	0	0	0	0
19-JAN-2002	13,555	0	0.0	0.0	0	0	0	0	0
20-JAN-2002	28,239	0	0.0	0.0	0	0	0	0	0
21-JAN-2002	15,814	0	0.0	0.0	0	0	0	0	0
22-JAN-2002	40,934	55,526	6.0	154.239	146,472	0	0	0	0
23-JAN-2002	21,044	17,710	3.0	98.389	0	0	0	0	0
24-JAN-2002	35,498	76,991	5.0	256.637	73,236	0	0	0	0
25-JAN-2002	29,928	0	0.0	0.0	0	0	0	0	0
26-JAN-2002	10,255	0	0.0	0.0	0	0	0	0	0
27-JAN-2002	8,947	0	0.0	0.0	0	0	0	0	0
28-JAN-2002	64,841	72,818	5.0	242.727	73,236	0	0	0	0
29-JAN-2002	40,502	73,236	6.0	203.433	73,236	0	0	0	0
30-JAN-2002	4,004	6,707	3.0	37.261	0	0	0	0	0
31-JAN-2002	26,078	45,446	4.0	189.358	0	0	0	0	0
JAN-2002									
Total	868,026	934,569	85.0		952,068	0	0	0	0
Maximum/Day	95,839	113,861	9.0	259.777	146,472				
Minimum/Day	4,004	6,707	3.0	37.261	73,236				
Average/Day	28,001	54,975	5.0	176.095	86,552				

02075

TA50 DAILY FLOWS (liters)

FEB-2002

	Influent	Treated	Time (hrs)	Rate (liters/min)	Effluent	DP	Misc	Recirc	Sludge
01-FEB-2002	16,943	0	0.0	0.0	0	0	0	0	0
02-FEB-2002	10,166	0	0.0	0.0	0	0	0	0	0
03-FEB-2002	11,786	0	0.0	0.0	0	0	0	0	0
04-FEB-2002	23,678	43,991	4.0	183.296	0	0	0	0	0
05-FEB-2002	15,041	0	0.0	0.0	0	0	0	0	0
06-FEB-2002	67,054	59,966	5.0	199.887	73,236	0	0	0	0
07-FEB-2002	13,653	32,411	4.0	135.046	73,236	0	0	0	0
08-FEB-2002	20,885	30,677	6.0	85.214	0	0	0	0	0
09-FEB-2002	8,982	0	0.0	0.0	0	0	0	0	0
10-FEB-2002	11,269	0	0.0	0.0	0	0	0	0	0
11-FEB-2002	72,565	0	0.0	0.0	66,548	0	0	43,050	0
12-FEB-2002	5,657	21,708	4.0	90.45	0	0	0	0	0
13-FEB-2002	29,022	89,144	8.0	185.717	0	0	0	0	0
14-FEB-2002	43,094	93,300	7.0	222.143	73,236	0	0	0	0
15-FEB-2002	13,528	0	0.0	0.0	0	0	0	0	0
16-FEB-2002	16,943	0	0.0	0.0	0	0	0	0	0
17-FEB-2002	14,684	0	0.0	0.0	0	0	0	0	0
18-FEB-2002	12,398	0	0.0	0.0	0	0	0	0	0
19-FEB-2002	26,503	42,409	4.0	176.704	73,236	0	0	0	0
20-FEB-2002	49,686	3,795	2.0	31.625	0	0	0	0	0
21-FEB-2002	49,512	57,195	5.0	190.65	73,236	0	0	0	0
22-FEB-2002	70,999	0	0.0	0.0	0	0	0	0	0
23-FEB-2002	21,489	0	0.0	0.0	0	0	0	0	0
24-FEB-2002	20,305	0	0.0	0.0	0	0	0	0	0
25-FEB-2002	47,029	70,931	8.0	147.773	72,630	0	0	0	0
26-FEB-2002	32,189	19,939	3.0	110.772	0	0	0	0	0
27-FEB-2002	36,316	33,581	2.0	279.842	0	0	0	0	0
28-FEB-2002	26,029	106,430	11.0	161.258	73,236	0	0	0	0
FEB-2002									
Total	787,405	705,477	73.0		578,594	0	0	43,050	0
Maximum/Day	72,565	106,430	11.0	279.842	73,236				
Minimum/Day	5,657	3,795	2.0	31.625	66,548				
Average/Day	28,122	50,391	5.214	157.17	72,324				

02076

TA50 DAILY FLOWS (liters)

MAR-2002

	Influent	Treated	Time (hrs)	Rate (liters/min)	Effluent	DP	Misc	Recirc	Sludge
01-MAR-2002	22,445	31,075	3.0	172.639	73,236	0	0	0	0
02-MAR-2002	19,229	0	0.0	0.0	0	0	0	0	0
03-MAR-2002	20,332	0	0.0	0.0	0	0	0	0	0
04-MAR-2002	35,125	53,142	5.0	177.14	0	0	0	0	0
05-MAR-2002	46,415	0	0.0	0.0	72,630	0	0	0	0
06-MAR-2002	94,851	128,033	7.0	304.84	72,630	0	0	0	0
07-MAR-2002	27,148	53,751	6.0	149.308	0	0	0	0	0
08-MAR-2002	20,842	0	0.0	0.0	0	0	0	0	0
09-MAR-2002	12,371	0	0.0	0.0	0	0	0	0	0
10-MAR-2002	10,899	0	0.0	0.0	0	0	0	0	0
11-MAR-2002	34,399	0	0.0	0.0	0	0	0	80,537	0
12-MAR-2002	5,424	48,035	6.0	133.431	73,236	0	0	0	0
13-MAR-2002	56,753	0	0.0	0.0	73,236	0	0	0	0
14-MAR-2002	35,350	91,038	8.0	189.662	0	0	0	0	0
15-MAR-2002	15,814	0	0.0	0.0	0	0	0	0	0
16-MAR-2002	22,591	0	0.0	0.0	0	0	0	0	0
17-MAR-2002	22,510	0	0.0	0.0	0	0	0	0	0
18-MAR-2002	29,969	43,026	5.0	143.42	72,630	0	0	0	0
19-MAR-2002	27,975	59,167	6.0	164.353	73,236	0	0	0	0
20-MAR-2002	14,754	54,206	7.0	129.062	73,236	0	0	0	0
21-MAR-2002	8,357	34,928	6.0	97.022	0	0	0	0	0
22-MAR-2002	75,399	0	0.0	0.0	0	0	0	0	0
23-MAR-2002	11,296	0	0.0	0.0	0	0	0	0	0
24-MAR-2002	9,036	0	0.0	0.0	0	0	0	0	0
25-MAR-2002	29,517	69,758	6.0	193.772	73,236	0	0	0	0
26-MAR-2002	4,490	0	0.0	0.0	0	0	0	29,353	0
27-MAR-2002	30,308	0	0.0	0.0	0	0	0	0	0
28-MAR-2002	53,968	0	0.0	0.0	0	0	0	0	0
29-MAR-2002	0	28,769	5.0	95.897	0	0	0	53,005	0
30-MAR-2002	11,738	0	0.0	0.0	0	0	0	0	0
31-MAR-2002	11,953	0	0.0	0.0	0	0	0	0	0
MAR-2002									
Total	821,278	694,928	70.0		657,306	0	0	162,895	0
Maximum/Day	94,851	128,033	8.0	304.84	73,236			80,537	
Minimum/Day	4,490	28,769	3.0	95.897	72,630			29,353	
Average/Day	26,493	57,911	5.833	162.546	73,034			54,298	

02077



TA50 DAILY FLOWS (liters)

APR-2002

	Influent	Treated	Time (hrs)	Rate (liters/min)	Effluent	DP	Misc	Recirc	Sludge
01-APR-2002	37,980	82,888	10.0	138.147	0	0	0	0	0
02-APR-2002	21,056	101,926	10.0	169.877	146,472	0	0	0	0
03-APR-2002	25,100	0	0.0	0.0	0	0	0	0	0
04-APR-2002	75,955	36,605	3.0	203.361	73,236	0	0	0	0
05-APR-2002	16,887	43,312	4.0	180.467	0	0	0	0	0
06-APR-2002	13,555	0	0.0	0.0	0	0	0	0	0
07-APR-2002	15,814	0	0.0	0.0	0	0	0	0	0
08-APR-2002	41,273	65,772	5.0	219.24	0	0	0	0	0
09-APR-2002	16,832	75,019	4.0	312.579	145,866	0	0	39,841	0
10-APR-2002	54,712	0	0.0	0.0	73,236	0	0	0	0
11-APR-2002	47,115	73,236	7.0	174.371	0	0	0	0	0
12-APR-2002	0	0	0.0	0.0	0	0	42,604	42,604	25,719
13-APR-2002	19,794	0	0.0	0.0	0	0	0	0	0
14-APR-2002	21,092	0	0.0	0.0	0	0	0	0	0
15-APR-2002	0	47,854	4.0	199.392	73,236	0	44,100	13,013	0
16-APR-2002	29,228	0	0.0	0.0	0	0	20,064	20,064	0
17-APR-2002	18,783	65,302	9.0	120.93	0	0	0	0	20,013
18-APR-2002	62,534	68,642	5.0	228.807	0	0	0	0	0
19-APR-2002	13,036	50,814	5.0	169.38	0	0	0	0	0
20-APR-2002	14,657	0	0.0	0.0	0	0	0	0	0
21-APR-2002	13,528	0	0.0	0.0	0	0	0	0	0
22-APR-2002	14,811	19,489	5.0	64.963	146,472	0	0	0	0
23-APR-2002	54,663	57,851	5.0	192.837	0	0	0	0	0
24-APR-2002	55,374	14,974	1.0	249.567	0	0	0	0	0
25-APR-2002	45,481	52,759	4.0	219.829	0	0	0	0	0
26-APR-2002	22,702	0	0.0	0.0	0	0	0	0	0
27-APR-2002	13,501	0	0.0	0.0	0	0	0	0	0
28-APR-2002	13,159	0	0.0	0.0	0	0	0	0	0
29-APR-2002	0	29,062	4.0	121.092	73,236	0	0	0	0
30-APR-2002	48,044	0	0.0	0.0	0	0	0	0	0
APR-2002									
Total	826,666	885,505	85.0		731,754	0	106,768	115,522	45,732
Maximum/Day	75,955	101,926	10.0	312.579	146,472		44,100	42,604	25,719
Minimum/Day	13,036	14,974	1.0	64.963	73,236		20,064	13,013	20,013
Average/Day	27,556	55,344	5.312	185.302	104,536		35,589	28,881	22,866

02078

TA50 DAILY FLOWS (liters)

MAY-2002

	Influent	Treated	Time (hrs)	Rate (liters/min)	Effluent	DP	Misc	Recirc	Sludge
01-MAY-2002	25,161	14,670	4.0	61.125	73,236	0	0	0	0
02-MAY-2002	20,196	38,986	5.0	129.953	0	0	0	0	0
03-MAY-2002	45,580	70,499	6.0	195.831	0	0	0	0	0
04-MAY-2002	15,814	0	0.0	0.0	0	0	0	0	0
05-MAY-2002	28,827	0	0.0	0.0	0	0	0	0	0
06-MAY-2002	19,861	26,981	6.0	74.947	73,236	0	0	0	0
07-MAY-2002	69,433	62,059	7.0	147.76	73,236	0	0	0	0
08-MAY-2002	23,770	121,647	6.0	337.908	0	0	0	63,444	0
09-MAY-2002	0	0	0.0	0.0	73,236	0	0	0	0
10-MAY-2002	84,262	112,191	4.0	467.462	0	0	0	42,337	0
12-MAY-2002	19,175	0	0.0	0.0	0	0	0	0	0
13-MAY-2002	62,764	37,618	6.0	104.494	73,236	0	0	0	0
14-MAY-2002	44,366	66,207	7.0	157.636	73,236	0	0	0	0
15-MAY-2002	61,587	33,253	8.0	69.277	73,236	0	0	0	0
16-MAY-2002	38,581	44,898	7.0	106.9	0	0	0	0	0
17-MAY-2002	41,587	49,108	5.0	163.693	0	0	0	0	0
18-MAY-2002	19,963	0	0.0	0.0	0	0	0	0	0
19-MAY-2002	20,023	0	0.0	0.0	0	0	0	0	0
20-MAY-2002	31,361	44,591	7.0	106.169	73,236	0	0	24,867	0
21-MAY-2002	40,214	50,185	6.0	139.403	0	0	0	0	0
22-MAY-2002	85,134	87,861	9.0	162.706	146,472	0	0	0	0
23-MAY-2002	44,463	86,193	10.0	143.655	72,630	0	0	0	0
24-MAY-2002	26,696	60,547	6.0	168.186	73,236	0	0	0	0
25-MAY-2002	0	0	0.0	0.0	0	0	0	0	0
26-MAY-2002	12,398	0	0.0	0.0	0	0	0	0	0
27-MAY-2002	11,269	0	0.0	0.0	0	0	0	0	0
28-MAY-2002	64,469	69,375	5.0	231.25	73,236	0	0	0	0
29-MAY-2002	46,212	66,262	5.0	220.873	69,375	0	0	0	0
30-MAY-2002	33,217	16,829	6.0	46.747	0	0	0	0	0
31-MAY-2002	29,813	0	0.0	0.0	0	0	0	0	0
MAY-2002									
Total	1,066,196	1,159,960	125.0		1,020,837	0	0	130,648	0
Maximum/Day	85,134	121,647	10.0	467.462	146,472			63,444	
Minimum/Day	11,269	14,670	4.0	46.747	69,375			24,867	
Average/Day	34,393	57,998	6.25	161.799	78,526			43,549	

02079

TA50 DAILY FLOWS (liters)

JUN-2002

	Influent	Treated	Time (hrs)	Rate (liters/min)	Effluent	DP	Misc	Recirc	Sludge
01-JUN-2002	18,551	0	0.0	0.0	0	0	0	0	0
02-JUN-2002	8,067	0	0.0	0.0	0	0	0	0	0
03-JUN-2002	58,997	58,657	5.0	195.523	0	0	0	0	0
04-JUN-2002	50,896	69,218	5.0	230.727	0	0	0	0	0
05-JUN-2002	42,349	35,887	2.0	299.058	73,236	0	0	0	0
06-JUN-2002	48,948	86,619	11.0	131.241	73,236	0	0	0	0
07-JUN-2002	17,252	49,135	6.0	136.486	73,236	0	0	54,815	0
08-JUN-2002	18,610	0	0.0	0.0	0	0	0	0	0
09-JUN-2002	16,096	0	0.0	0.0	0	0	0	0	0
10-JUN-2002	99,153	52,669	5.0	175.563	73,236	0	0	0	0
11-JUN-2002	93,281	113,348	7.0	269.876	0	0	0	40,269	0
12-JUN-2002	21,009	93,976	7.0	223.752	0	0	0	90,620	0
13-JUN-2002	66,674	93,150	11.0	141.136	73,236	0	0	0	0
14-JUN-2002	90,447	89,021	3.0	494.561	72,006	0	0	0	0
15-JUN-2002	17,199	0	0.0	0.0	0	0	0	0	0
16-JUN-2002	16,661	0	0.0	0.0	0	0	0	0	0
17-JUN-2002	8,364	0	0.0	0.0	73,236	0	0	0	0
18-JUN-2002	68,713	70,583	6.0	196.064	0	0	0	0	0
19-JUN-2002	58,371	62,849	5.0	209.497	73,236	0	0	0	0
20-JUN-2002	3,176	62,242	9.0	115.263	73,236	0	0	0	0
21-JUN-2002	56,882	44,564	7.0	106.105	67,986	0	0	0	0
22-JUN-2002	45,574	0	0.0	0.0	0	0	0	0	0
23-JUN-2002	39,068	0	0.0	0.0	0	0	0	0	0
24-JUN-2002	59,980	87,951	10.0	146.585	73,236	0	0	0	0
25-JUN-2002	38,990	92,671	10.0	154.452	73,236	0	0	0	0
26-JUN-2002	54,104	109,927	11.0	166.556	146,472	0	0	0	0
27-JUN-2002	28,983	85,629	10.0	142.715	73,236	0	0	34,048	0
28-JUN-2002	37,377	93,909	7.0	223.593	73,236	0	0	0	0
29-JUN-2002	122,518	0	0.0	0.0	0	0	0	0	0
30-JUN-2002	0	0	0.0	0.0	0	0	0	0	0
JUN-2002									
Total	1,306,290	1,452,005	137.0		1,165,296	0	0	219,752	0
Maximum/Day	122,518	113,348	11.0	494.561	146,472			90,620	
Minimum/Day	3,176	35,887	2.0	106.105	67,986			34,048	
Average/Day	43,543	78,421	7.211	197.829	77,686			54,938	

020800

**TA50 DAILY FLOWS (liters)**  
JUL-2002

	Influent	Treated	Time (hrs)	Rate (liters/min)	Effluent	DP	Misc	Recirc	Sludge
01-JUL-2002	31,760	78,853	7.0	187.745	0	0	0	0	0
02-JUL-2002	70,507	69,462	7.0	165.386	73,236	0	0	10,785	0
03-JUL-2002	69,018	115,921	7.0	276.002	73,236	0	0	0	0
04-JUL-2002	23,653	0	0.0	0.0	73,236	0	0	0	0
05-JUL-2002	11,026	42,334	5.0	141.113	73,236	0	0	0	0
06-JUL-2002	23,159	0	0.0	0.0	0	0	0	0	0
07-JUL-2002	27,261	0	0.0	0.0	0	0	0	0	0
08-JUL-2002	60,038	73,058	4.0	304.408	73,236	0	0	0	0
09-JUL-2002	65,347	73,236	6.0	203.433	73,236	0	0	0	0
10-JUL-2002	31,150	20,795	6.0	57.764	73,236	0	0	0	0
11-JUL-2002	70,629	96,354	9.0	178.433	73,236	0	0	0	0
12-JUL-2002	53,261	67,083	4.0	279.512	0	0	0	0	0
13-JUL-2002	38,583	0	0.0	0.0	0	0	0	0	0
14-JUL-2002	37,248	0	0.0	0.0	0	0	0	0	0
15-JUL-2002	33,833	39,120	3.0	217.333	145,242	0	0	0	0
16-JUL-2002	75,255	112,899	8.0	235.206	0	0	0	72,284	0
17-JUL-2002	56,484	102,486	8.0	213.512	146,472	0	0	13,904	0
18-JUL-2002	58,464	131,893	8.0	274.777	73,236	0	0	0	0
19-JUL-2002	61,064	48,747	2.0	406.225	73,236	0	0	0	0
20-JUL-2002	27,055	0	0.0	0.0	0	0	0	0	0
21-JUL-2002	28,239	0	0.0	0.0	0	0	0	0	0
22-JUL-2002	45,920	89	4.0	0.371	72,006	0	0	0	0
23-JUL-2002	32,181	67,626	7.0	161.014	0	0	0	0	0
24-JUL-2002	43,768	80,439	6.0	223.442	73,236	0	0	10,696	0
25-JUL-2002	29,995	1,783	9.0	3.302	72,630	0	0	0	0
26-JUL-2002	31,360	79,118	6.0	219.772	0	0	0	0	0
27-JUL-2002	18,295	0	0.0	0.0	0	0	0	0	0
28-JUL-2002	18,157	0	0.0	0.0	0	0	0	0	0
29-JUL-2002	60,044	0	0.0	0.0	73,236	0	0	7,130	0
30-JUL-2002	38,863	89,466	7.0	213.014	0	0	0	0	0
31-JUL-2002	82,578	86,443	3.0	480.239	146,472	0	0	0	0
JUL-2002									
Total	1,354,195	1,477,205	126.0		1,461,654	0	0	114,799	0
Maximum/Day	82,578	131,893	9.0	480.239	146,472			72,284	
Minimum/Day	11,026	89	2.0	0.371	72,006			7,130	
Average/Day	43,684	70,343	6.0	211.524	85,980			22,960	

100201

TA50 DAILY FLOWS (liters)  
AUG-2002

	Influent	Treated	Time (hrs)	Fate (liters/min)	Effluent	DP	Misc	Recirc	Sludge
01-AUG-2002	45,155	0	0.0	0.0	0	0	0	0	0
02-AUG-2002	58,827	39,527	3.0	219.594	73,236	0	0	0	0
03-AUG-2002	45,155	0	0.0	0.0	0	0	0	0	0
04-AUG-2002	42,641	0	0.0	0.0	0	0	0	0	0
05-AUG-2002	72,644	78,300	6.0	217.5	0	0	0	16,935	0
06-AUG-2002	57,274	102,407	7.0	243.826	73,236	0	0	0	0
07-AUG-2002	0	0	0.0	0.0	0	0	0	0	0
08-AUG-2002	50,672	94,750	7.0	225.595	145,866	0	0	0	0
09-AUG-2002	0	30,261	3.0	168.117	0	0	0	0	0
10-AUG-2002	0	0	0.0	0.0	0	0	0	0	0
11-AUG-2002	0	0	0.0	0.0	0	0	0	0	0
12-AUG-2002	13,982	58,439	5.0	194.797	72,006	0	0	0	0
13-AUG-2002	37,908	0	0.0	0.0	0	0	0	0	0
14-AUG-2002	23,276	63,641	5.0	212.137	73,236	0	0	0	0
15-AUG-2002	17,513	78,468	4.0	326.95	73,236	0	0	0	0
16-AUG-2002	20,278	0	0.0	0.0	0	0	0	0	0
17-AUG-2002	14,684	0	0.0	0.0	0	0	0	0	0
18-AUG-2002	13,528	0	0.0	0.0	0	0	0	0	0
19-AUG-2002	28,089	53,217	5.0	177.39	73,236	0	0	0	0
20-AUG-2002	38,109	0	0.0	0.0	0	0	0	0	0
21-AUG-2002	78,387	79,906	5.0	266.353	0	0	0	0	0
22-AUG-2002	19,278	0	0.0	0.0	72,630	0	0	0	0
23-AUG-2002	28,570	57,636	5.0	192.12	0	0	0	0	0
24-AUG-2002	13,528	0	0.0	0.0	0	0	0	0	0
25-AUG-2002	15,787	0	0.0	0.0	0	0	0	0	0
26-AUG-2002	73,619	80,258	5.0	267.527	73,236	0	0	0	0
27-AUG-2002	50,893	42,996	5.0	143.32	73,236	0	0	0	0
28-AUG-2002	47,814	69,735	4.0	290.562	0	0	0	0	0
29-AUG-2002	37,278	66,480	4.0	277.0	73,236	0	0	0	0
30-AUG-2002	20,005	16,603	2.0	138.358	0	0	0	0	0
31-AUG-2002	19,202	0	0.0	0.0	0	0	0	0	0
AUG-2002									
Total	984,096	1,012,624	75.0		876,390	0	0	16,935	0
Maximum/Day	78,387	102,407	7.0	326.95	145,866				
Minimum/Day	13,528	16,603	2.0	138.358	72,006				
Average/Day	31,745	63,289	4.688	222.572	79,672				

02082

TA50 DAILY FLOWS (liters)

SEP-2002

	Influent	Treated	Time (hrs)	Rate (liters/min)	Effluent	DP	Misc	Recirc	Sludge
01-SEP-2002	14,315	0	0.0	0.0	0	0	0	0	0
02-SEP-2002	16,943	0	0.0	0.0	0	0	0	0	0
03-SEP-2002	15,044	36,665	4.0	152.771	72,630	0	0	0	0
04-SEP-2002	26,751	57,180	4.0	238.25	69,375	0	0	0	0
05-SEP-2002	57,173	86,911	4.0	362.129	0	0	0	0	0
06-SEP-2002	41,494	0	0.0	0.0	0	0	0	0	0
07-SEP-2002	18,795	0	0.0	0.0	0	0	0	0	0
08-SEP-2002	20,975	0	0.0	0.0	0	0	0	0	0
09-SEP-2002	43,160	77,613	6.0	215.592	72,630	0	0	0	0
10-SEP-2002	10,117	0	0.0	0.0	73,236	0	0	0	0
11-SEP-2002	36,397	75,978	5.0	253.26	0	0	0	0	0
12-SEP-2002	15,224	41,060	5.0	136.867	73,236	0	0	0	0
13-SEP-2002	19,902	0	0.0	0.0	0	0	0	0	0
14-SEP-2002	15,787	0	0.0	0.0	0	0	0	0	0
15-SEP-2002	12,922	0	0.0	0.0	0	0	0	0	0
16-SEP-2002	38,534	17,674	1.0	294.567	72,630	0	0	0	0
17-SEP-2002	44,146	82,165	7.0	195.631	0	0	0	0	0
18-SEP-2002	0	51,258	5.0	170.86	73,236	0	0	0	0
19-SEP-2002	106,570	0	0.0	0.0	73,236	0	0	0	0
20-SEP-2002	0	0	0.0	0.0	0	0	0	0	0
21-SEP-2002	15,841	0	0.0	0.0	0	0	0	0	0
22-SEP-2002	45,711	0	0.0	0.0	0	0	0	0	0
23-SEP-2002	25,137	33,313	7.0	79.317	73,236	0	0	0	0
24-SEP-2002	7,471	34,187	6.0	94.964	0	0	0	0	0
25-SEP-2002	0	59,621	6.0	165.614	73,236	0	0	0	0
26-SEP-2002	6,381	117,270	6.0	325.75	73,236	0	0	0	0
27-SEP-2002	0	0	0.0	0.0	0	0	0	0	0
28-SEP-2002	13,555	0	0.0	0.0	0	0	0	0	0
29-SEP-2002	16,574	0	0.0	0.0	0	0	0	0	0
30-SEP-2002	42,510	75,344	6.0	209.289	73,236	0	0	0	0
SEP-2002									
Total	727,429	846,239	72.0		873,153	0	0	0	0
Maximum/Day	106,570	117,270	7.0	362.129	73,236				
Minimum/Day	6,381	17,674	1.0	79.317	69,375				
Average/Day	24,248	60,446	5.143	206.776	72,763				

02083

TA50 DAILY FLOWS (liters)

OCT-2002

	Influent	Treated	Time (hrs)	Rate (liters/min)	Effluent	DP	Misc	Recirc	Sludge
01-OCT-2002	0	0	0.0	0.0	73,236	0	0	0	0
02-OCT-2002	0	80,735	5.0	269.117	0	0	0	0	0
03-OCT-2002	17,302	0	0.0	0.0	73,236	0	0	0	0
04-OCT-2002	0	0	0.0	0.0	0	0	0	0	0
05-OCT-2002	15,603	0	0.0	0.0	0	0	0	0	0
06-OCT-2002	26,867	0	0.0	0.0	0	0	0	0	0
07-OCT-2002	82,604	97,123	6.0	269.786	0	0	0	25,848	0
08-OCT-2002	3,925	31,947	6.0	88.742	72,630	0	0	0	0
09-OCT-2002	67,841	92,420	5.0	308.067	73,236	0	0	0	0
10-OCT-2002	43,866	109,756	7.0	261.324	72,630	0	0	0	0
11-OCT-2002	39,780	0	0.0	0.0	0	0	0	0	0
12-OCT-2002	23,918	0	0.0	0.0	0	0	0	0	0
13-OCT-2002	13,501	0	0.0	0.0	0	0	0	0	0
14-OCT-2002	15,491	0	0.0	0.0	0	0	0	0	0
15-OCT-2002	16,526	71,099	7.0	169.283	72,630	0	0	0	0
16-OCT-2002	0	63,106	2.0	525.883	72,630	0	0	0	0
17-OCT-2002	43,699	87,555	6.0	243.208	73,236	0	0	0	0
18-OCT-2002	35,016	0	0.0	0.0	0	0	0	0	0
19-OCT-2002	13,528	0	0.0	0.0	0	0	0	0	0
20-OCT-2002	12,452	0	0.0	0.0	0	0	0	0	0
21-OCT-2002	41,914	31,122	4.0	129.675	72,630	0	0	0	0
22-OCT-2002	55,197	93,713	5.0	312.377	0	0	0	0	0
23-OCT-2002	25,419	0	0.0	0.0	145,412	0	0	0	0
24-OCT-2002	51,057	72,782	5.0	242.607	0	0	0	0	0
25-OCT-2002	11,122	0	0.0	0.0	0	0	0	20,500	0
26-OCT-2002	14,684	0	0.0	0.0	0	0	0	0	0
27-OCT-2002	16,943	0	0.0	0.0	0	0	0	0	0
28-OCT-2002	70,779	83,259	4.0	346.913	73,236	0	0	0	0
29-OCT-2002	37,088	0	0.0	0.0	0	0	0	0	0
30-OCT-2002	93,169	43,152	3.0	239.733	73,236	0	0	0	0
31-OCT-2002	17,072	74,821	7.0	177.669	0	0	0	0	0
OCT-2002									
Total	906,363	1,032,390	72.0		947,978	0	0	46,348	0
Maximum/Day	93,169	109,756	7.0	525.883	145,412			25,848	
Minimum/Day	3,925	31,122	2.0	88.742	72,630			20,500	
Average/Day	29,238	73,742	5.143	256.027	78,998			23,174	

0208

TA50 DAILY FLOWS (liters)

NOV-2002

	Influent	Treated	Time (hrs)	Rate (liters/min)	Effluent	DP	Misc	Recirc	Sudge
01-NOV-2002	0	24,489	3.0	136.05	0	0	0	30,304	0
02-NOV-2002	22,618	0	0.0	0.0	0	0	0	0	0
03-NOV-2002	20,332	0	0.0	0.0	0	0	0	0	0
04-NOV-2002	389,606	0	0.0	0.0	0	0	0	0	0
05-NOV-2002	59,835	46,590	3.0	258.833	146,472	0	0	0	0
06-NOV-2002	71,359	129,488	8.0	269.767	0	0	0	0	0
07-NOV-2002	32,212	37,813	4.0	157.554	72,630	0	0	0	0
08-NOV-2002	48,764	99,846	5.0	332.82	150,935	0	0	9,845	0
09-NOV-2002	36,077	0	0.0	0.0	0	0	0	0	0
10-NOV-2002	19,855	0	0.0	0.0	0	0	0	0	0
11-NOV-2002	16,943	0	0.0	0.0	0	0	0	0	0
12-NOV-2002	62,279	90,328	5.0	301.093	0	0	0	0	0
13-NOV-2002	53,376	67,736	5.0	225.787	73,236	0	0	14,360	0
14-NOV-2002	67,913	79,929	7.0	190.307	64,319	0	0	8,312	0
15-NOV-2002	26,504	0	0.0	0.0	0	0	0	0	0
16-NOV-2002	0	0	0.0	0.0	0	0	0	0	0
17-NOV-2002	0	0	0.0	0.0	0	0	0	0	0
18-NOV-2002	51,696	41,533	7.0	98.888	72,006	0	0	0	0
19-NOV-2002	30,185	14,563	5.0	48.543	72,630	0	0	0	0
20-NOV-2002	44,758	87,600	7.0	208.571	0	0	0	0	0
21-NOV-2002	46,031	90,340	5.0	301.133	73,236	0	0	15,844	0
22-NOV-2002	28,548	0	0.0	0.0	0	0	0	0	0
23-NOV-2002	26,027	0	0.0	0.0	0	0	0	0	0
24-NOV-2002	19,813	0	0.0	0.0	0	0	0	0	0
25-NOV-2002	32,127	84,409	7.0	200.974	144,000	0	0	0	0
26-NOV-2002	90,586	83,380	5.0	277.933	73,236	0	0	0	0
27-NOV-2002	0	0	0.0	0.0	0	0	0	0	0
28-NOV-2002	15,912	0	0.0	0.0	0	0	0	0	0
29-NOV-2002	18,638	0	0.0	0.0	0	0	0	0	0
30-NOV-2002	18,073	0	0.0	0.0	0	0	0	0	0
NOV-2002									
Total	1,350,067	978,044	76.0		942,700	0	0	78,665	0
Maximum/Day	389,606	129,488	8.0	332.82	150,935			30,304	
Minimum/Day	15,912	14,563	3.0	48.543	64,319			8,312	
Average/Day	45,002	69,860	5.429	214.875	94,270			15,733	

02085



TA50 DAILY FLOWS (liters)

DEC-2002

	Influent	Treated	Time (hrs)	Rate (liters/min)	Effluent	DP	Misc	Recirc	Sludge
01-DEC-2002	16,281	0	0.0	0.0	0	0	0	0	0
02-DEC-2002	0	58,005	5.0	193.35	146,472	0	27,405	25,848	0
03-DEC-2002	25,078	47,854	4.0	199.392	0	0	0	0	0
04-DEC-2002	22,260	0	0.0	0.0	0	0	0	0	0
05-DEC-2002	48,057	99,509	7.0	236.926	72,630	0	0	0	0
06-DEC-2002	75,137	0	0.0	0.0	73,236	0	0	0	0
07-DEC-2002	18,046	0	0.0	0.0	0	0	0	0	0
08-DEC-2002	17,777	0	0.0	0.0	0	0	0	0	0
09-DEC-2002	0	71,700	8.0	149.375	73,236	0	0	0	0
10-DEC-2002	12,143	0	0.0	0.0	0	0	0	0	0
11-DEC-2002	78,966	120,229	6.0	333.969	0	0	0	0	0
12-DEC-2002	0	0	0.0	0.0	73,236	0	0	18,543	0
13-DEC-2002	12,082	61,834	6.0	172.039	73,236	0	0	0	0
14-DEC-2002	14,442	0	0.0	0.0	0	0	0	0	0
15-DEC-2002	13,003	0	0.0	0.0	0	0	0	0	0
16-DEC-2002	60,415	70,585	4.0	294.104	73,236	0	0	0	0
17-DEC-2002	77,630	73,959	5.0	246.53	70,719	0	0	0	0
18-DEC-2002	0	0	0.0	0.0	0	0	0	28,522	0
19-DEC-2002	29,848	77,324	6.0	214.789	73,236	0	0	0	0
20-DEC-2002	37,002	9,576	6.0	26.6	73,236	0	0	0	0
21-DEC-2002	15,733	0	0.0	0.0	0	0	0	0	0
22-DEC-2002	16,096	0	0.0	0.0	0	0	0	0	0
23-DEC-2002	18,161	76,945	7.0	183.202	0	0	0	0	0
24-DEC-2002	187,169	38,350	3.0	213.056	0	0	0	0	0
25-DEC-2002	116,771	0	0.0	0.0	0	0	0	0	0
26-DEC-2002	14,109	0	0.0	0.0	0	0	0	0	0
27-DEC-2002	13,713	0	0.0	0.0	0	0	0	0	0
28-DEC-2002	11,429	0	0.0	0.0	0	0	0	0	0
29-DEC-2002	12,038	0	0.0	0.0	0	0	0	0	0
30-DEC-2002	12,899	0	0.0	0.0	0	0	0	0	0
31-DEC-2002	11,756	0	0.0	0.0	0	0	0	0	0
DEC-2002									
Total	988,041	805,970	67.0		802,473	0	27,405	72,913	0
MaximumDay	187,169	120,229	8.0	333.969	146,472			28,522	
MinimumDay	11,429	9,576	3.0	26.6	70,719			18,543	
AverageDay	31,872	67,164	5.583	205.278	80,247			24,304	

02086

## TA50 DAILY FLOWS (liters)

JAN-2002 through DEC-2002

	Influent	Treated	Time (hrs)	Rate (liters/min)	Effluent	DP	Misc	Recirc	Sludge
<b>SUMMARY</b>									
Total	11,986,052	11,984,916	1063.0		11,010,203	0	134,173	1,001,527	45,732
Maximum/Month	1,354,195	1,477,205			1,461,654	0	106,768	219,752	45,732
Minimum/Month	727,429	694,928			578,594		27,405	16,935	45,732
Average/Month	998,838	998,743	88.583	187.91	917,517	0	11,181	83,461	3,811

**Appendix C**

**TA-50 RLWTF Monthly Radioisotope Summary**

# TA50 RADIOISOTOPES

JAN-2002

	RAW nCi/L	RAW Total (Ci)		FINAL pCi/l	FINAL Total (Ci)
ALPHA	79.0	73.831e-3		39.0	37.131e-6
Am-241	19.0	17.757e-3		23.0	21.898e-6
BETA	25.0	23.364e-3		760.0	723.572e-6
Cs-137	LDL*			15.0	14.281e-6
Np-237	LDL*			LDL*	
Pu-238	54.0	50.467e-3		14.0	13.329e-6
Pu-239	14.0	13.084e-3		4.4	4.189e-6
Ra-226	LDL*			LDL*	
Ra-228	LDL*			LDL*	
Rb-83				LDL*	
Sr-89	LDL*			LDL*	
Sr-90	LDL*			LDL*	
TOTAL PLUTONIUM	68.0	63.551e-3		18.4	17.518e-6
TRITIUM	35.0	32.71e-3		4300.0	4.094e-3
Th-232	LDL*			LDL*	
U-234	130.0e-3	121.494e-6		4.6	4.38e-6
U-235	LDL*			LDL*	
U-238	160.0e-3	149.531e-6		LDL*	
Total Alpha		81.429e-3			43.795e-6

Volume of Flow: Influent = 868,026.0 liters      Final = 952,068.0 liters

\*LDL: Less than Detection Limit.

# TA50 RADIOISOTOPES

FEB-2002

	RAW nCi/L	RAW Total (Ci)		FINAL pCi/l	FINAL Total (Ci)
ALPHA	74.0	52.205e-3		42.0	24.301e-6
Am-241	29.0	20.459e-3		14.0	8.1e-6
BETA	LDL*			90.0	52.073e-6
Cs-137	LDL*			13.0	7.522e-6
Np-237	LDL*			LDL*	
Pu-238	33.0	23.281e-3		22.0	12.729e-6
Pu-239	9.3	6.561e-3		4.8	2.777e-6
Ra-226	LDL*			LDL*	
Ra-228	LDL*			LDL*	
Sr-89	LDL*			LDL*	
Sr-90	LDL*			LDL*	
TOTAL PLUTONIUM	42.3	29.842e-3		26.8	15.506e-6
TRITIUM	46.0	32.452e-3		10000.0	5.786e-3
Th-232	LDL*			LDL*	
U-234	170.0e-3	119.931e-6		LDL*	
U-235	95.0e-3	67.02e-6		LDL*	
U-238	270.0e-3	190.479e-6		LDL*	
Total Alpha		50.487e-3			23.607e-6

Volume of Flow: Influent = 787,405.0 liters      Final = 578,594.0 liters

\*LDL: Less than Detection Limit.

# TA50 RADIOISOTOPES

MAR-2002

	RAW nCi/L	RAW Total (Ci)		FINAL pCi/l	FINAL Total (Ci)
ALPHA	91.0	63.238e-3		22.0	14.461e-6
Am-241	35.0	24.322e-3		17.0	11.174e-6
As-74				28.0	18.405e-6
BETA	LDL*			290.0	190.619e-6
Be-7	180.0e-3	125.087e-6			
Co-56				2.2	1.446e-6
Cs-137	LDL*			7.7	5.061e-6
Na-22	190.0e-3	132.036e-6			
Np-237				LDL*	
Pu-238	17.0	11.814e-3		7.7	5.061e-6
Pu-239	22.0	15.288e-3		LDL*	
Pu-226	28.0e-3	19.458e-6		LDL*	
Pu-228	LDL*			LDL*	
Pb-83				35.0	23.006e-6
Sr-85	58.0e-3	40.306e-6			
Sr-89	LDL*			LDL*	
Sr-90	LDL*			LDL*	
TOTAL PLUTONIUM	39.0	27.102e-3		LDL*	
TRITIUM	38.0	26.407e-3		6700.0	4.404e-3
Th-232	LDL*			LDL*	
U-234	140.0e-3	97.29e-6		LDL*	
U-235	LDL*			LDL*	
U-238	160.0e-3	111.188e-6		LDL*	
Total Alpha		51.522e-3			16.235e-6

Volume of Flow: Influent = 821,278.0 liters Final = 657,306.0 liters

\*LDL: Less than Detection Limit.

# TA50 RADIOISOTOPES

APR-2002

	RAW nCi/L	RAW Total (Ci)		FINAL pCi/l	FINAL Total (Ci)
ALPHA	98.0	86.779e-3		5.0	3.659e-6
Am-241	53.0	46.932e-3		8.1	5.927e-6
As-74	30.0e-3	26.565e-6		21.0	15.367e-6
BETA	LDL*			LDL*	
Cs-137	LDL*			3.1	2.268e-6
Na-22				6.9	5.049e-6
Np-237				LDL*	
Pu-238	31.0	27.451e-3		6.4	4.683e-6
Pu-239	13.0	11.512e-3		2.7	1.976e-6
Ra-226				LDL*	
Ra-228				LDL*	
Pb-83				2.8	2.049e-6
Sr-89	LDL*			LDL*	
Sr-90	79.0e-3	69.955e-6		LDL*	
TOTAL PLUTONIUM	44.0	38.962e-3		9.1	6.659e-6
TRITIUM	8.4	7.438e-3		4200.0	3.073e-3
Th-232				LDL*	
U-234	160.0e-3	141.681e-6		LDL*	
U-235	LDL*			LDL*	
U-238	LDL*			LDL*	
Total Alpha		86.036e-3			12.586e-6

Volume of Flow: Influent = 826,666.0 liters      Final = 731,754.0 liters

\*LDL: Less than Detection Limit.

# TA50 RADIOISOTOPES

MAY-2002

	RAW nCi/L	RAW Total (Ci)		FINAL pCi/l	FINAL Total (Ci)
ALPHA	300.0	347.988e-3		12.0	12.25e-6
Am-241	16.0	18.559e-3		9.6	9.8e-6
As-74				13.0	13.271e-6
BETA	160.0e-3	185.594e-6		130.0	132.709e-6
Cs-137	LDL*			LDL*	
Na-22	61.0e-3	70.758e-6		5.6	5.717e-6
Pu-238	54.0	62.638e-3		5.6	5.717e-6
Pu-239	26.0	30.159e-3		2.0	2.042e-6
Ra-226				4.6	4.696e-6
Ra-228	18.0e-3	20.879e-6		5.7	5.819e-6
Rb-83	22.0e-3	25.519e-6			
Rb-84				3.7	3.777e-6
Sr-85	63.0e-3	73.077e-6			
Sr-89	LDL*			LDL*	
Sr-90	LDL*			LDL*	
TOTAL PLUTONIUM	80.0	92.797e-3		7.6	7.758e-6
TRITIUM	20.0	23.199e-3		7300.0	7.452e-3
U-234	LDL*			LDL*	
U-235	LDL*			LDL*	
U-238	140.0e-3	162.394e-6		LDL*	
Zn-65				3.2	3.267e-6
Total Alpha		111.356e-3			17.558e-6

Volume of Flow: Influent = 1,066,196.0 liters      Final = 1,020,837.0 liters

\*LDL: Less than Detection Limit.



# TA50 RADIOISOTOPES

JUN-2002

	RAW nCi/L	RAW Total (Ci)		FINAL pCi/l	FINAL Total (Ci)
ALPHA	400.0	580.802e-3		13.0	15.149e-6
Am-241	200.0	290.401e-3		14.0	16.314e-6
As-74				36.0	41.951e-6
BETA	LDL*			330.0	384.548e-6
Be-7				LDL*	
Ce-141				LDL*	
Co-56				LDL*	
Co-57				LDL*	
Co-58				LDL*	
Co-60				LDL*	
Cs-134				LDL*	
Cs-137	170.0e-3	246.841e-6		19.0	22.141e-6
Eu-152				LDL*	
I-133				LDL*	
Mn-52				LDL*	
Mn-54	33.0e-3	47.916e-6		LDL*	
Na-22	100.0e-3	145.2e-6		12.0	13.984e-6
Np-237				LDL*	
Pu-238	130.0	188.761e-3		6.1	7.108e-6
Pu-239	56.0	81.312e-3		2.5	2.913e-6
Ra-226				14.0	16.314e-6
Ra-228				LDL*	
Rb-83				LDL*	
Rb-84				LDL*	
Sc-46				LDL*	
Sc-48				LDL*	
Se-75				LDL*	
Sn-113				LDL*	
Sr-85				LDL*	
Sr-89	LDL*			LDL*	
Sr-90	68.0e-3	98.736e-6		LDL*	
TOTAL PLUTONIUM	186.0	270.073e-3		8.6	10.022e-6
TRITIUM	7.7	11.18e-3		7300.0	8.507e-3
Th-232				LDL*	
U-234	43.0e-3	62.436e-6		570.0e-3	664.219e-9
U-235	LDL*			LDL*	
U-238	LDL*			LDL*	
V-48				LDL*	
Y-88				LDL*	
Zn-65	1.0	1.452e-3		LDL*	
Total Alpha		560.536e-3			27.0e-6

Volume of Flow: Influent = 1,306,290.0 liters      Final = 1,165,296.0 liters

\*LDL: Less than Detection Limit.

# TA50 RADIOISOTOPES

JUL-2002

	RAW nCi/L	RAW Total (Ci)		FINAL pCi/l	FINAL Total (Ci)
ALPHA	150.0	221.581e-3		LDL*	
Am-241	110.0	162.493e-3		5.0	7.308e-6
As-74				28.0	40.926e-6
BETA	3.5	5.17e-3		LDL*	
Be-7				LDL*	
Ce-141				LDL*	
Co-56				LDL*	
Co-57				LDL*	
Co-58				LDL*	
Co-60				LDL*	
Cs-134				LDL*	
Cs-137	93.0e-3	137.38e-6		26.0	38.003e-6
Eu-152				LDL*	
I-133				LDL*	
Mn-52				LDL*	
Mn-54				LDL*	
Na-22				9.4	13.74e-6
Np-237				LDL*	
Pu-238	35.0	51.702e-3		4.3	6.285e-6
Pu-239	17.0	25.112e-3		1.9	2.777e-6
Ra-226				LDL*	
Ra-228				LDL*	
Rb-83				LDL*	
Rb-84				LDL*	
Sc-46				LDL*	
Sc-48				LDL*	
Se-75				LDL*	
Sn-113				LDL*	
Sr-85				LDL*	
Sr-89	LDL*			LDL*	
Sr-90	LDL*			LDL*	
TOTAL PLUTONIUM	52.0	76.815e-3		6.2	9.062e-6
TRITIUM				7400.0	10.816e-3
Th-232				LDL*	
U-234	370.0e-3	546.566e-6		LDL*	
U-235	LDL*			LDL*	
U-238	LDL*			LDL*	
V-48				LDL*	
Y-88				LDL*	
Zn-65	160.0e-3	236.353e-6		LDL*	
Total Alpha		239.854e-3			16.371e-6

Volume of Flow: Influent = 1,354,195.0 liters Final = 1,461,654.0 liters

\*LDL: Less than Detection Limit.

# TA50 RADIOISOTOPES

AUG-2002

	RAW nCi/L	RAW Total (Ci)		FINAL pCi/l	FINAL Total (Ci)
ALPHA	93.0	94.174e-3		LDL*	
Am-241	85.0	86.073e-3		5.5	4.82e-6
As-74				31.0	27.168e-6
BETA	LDL*			37.0	32.426e-6
Be-7				LDL*	
Ce-141				LDL*	
Co-56				LDL*	
Co-57				LDL*	
Co-58				LDL*	
Co-60				LDL*	
Cs-134				LDL*	
Cs-137	65.0e-3	65.821e-6		50.0	43.819e-6
Eu-152				LDL*	
I-133				LDL*	
Mn-52				LDL*	
Mn-54				LDL*	
Na-22				LDL*	
Np-237				LDL*	
Pu-238	48.0	48.606e-3		4.2	3.681e-6
Pu-239	21.0	21.265e-3		1.3	1.139e-6
Ra-226				8.8	7.712e-6
Ra-228				9.4	8.238e-6
Rb-83				LDL*	
Rb-84				LDL*	
Sc-46				LDL*	
Sc-48				LDL*	
Se-75				LDL*	
Sn-113				LDL*	
Sr-85				LDL*	
Sr-89	LDL*			LDL*	
Sr-90	LDL*			LDL*	
TOTAL PLUTONIUM	69.0	69.871e-3		LDL*	
TRITIUM				7900.0	6.923e-3
Th-232	1.1e-3	1.114e-6		LDL*	
U-234	1.2	1.215e-3		LDL*	
U-235	LDL*			LDL*	
U-238	LDL*			LDL*	
V-48				LDL*	
Y-88				LDL*	
Zn-65				5.4	4.733e-6
Total Alpha		157.159e-3			9.64e-6

Volume of Flow: Influent = 984,096.0 liters      Final = 876,390.0 liters

\*LDL: Less than Detection Limit.

# TA50 RADIOISOTOPES

SEP-2002

	RAW nCi/L	RAW Total (Ci)		FINAL pCi/l	FINAL Total (Ci)
ALPHA	590.0	499.281e-3		26.0	22.702e-6
Am-241	200.0	169.248e-3		3.7	3.231e-6
As-74				11.0	9.605e-6
BETA	24.0	20.31e-3		110.0	96.047e-6
Be-7				LDL*	
Ce-141				LDL*	
Co-56				LDL*	
Co-57				LDL*	
Co-58				LDL*	
Co-60				LDL*	
Cs-134				LDL*	
Cs-137	66.0e-3	55.852e-6		37.0	32.307e-6
Eu-152				LDL*	
I-133				LDL*	
Mn-52				LDL*	
Mn-54				LDL*	
Na-22				4.0	3.493e-6
Np-237				LDL*	
Pu-238	180.0	152.323e-3		2.7	2.358e-6
Pu-239	65.0	55.006e-3		600.0e-3	523.892e-9
Ra-226				LDL*	
Ra-228				LDL*	
Rb-83				LDL*	
Rb-84				LDL*	
Sc-46				LDL*	
Sc-48				LDL*	
Se-75				LDL*	
Sn-113				LDL*	
Sr-85				LDL*	
Sr-89	LDL*			LDL*	
Sr-90	LDL*			LDL*	
TOTAL PLUTONIUM	245.0	207.329e-3		3.3	2.881e-6
TRITIUM				9500.0	8.295e-3
Th-232	520.0e-6	440.044e-9		LDL*	
U-234	2.1	1.777e-3		LDL*	
U-235	LDL*			LDL*	
U-238	3.5	2.962e-3		LDL*	
V-48				LDL*	
Y-88				LDL*	
Zn-65	260.0e-3	220.022e-6		LDL*	
Total Alpha		378.353e-3			6.112e-6

Volume of Flow: Influent = 727,429.0 liters Final = 873,153.0 liters

\*LDL: Less than Detection Limit.

# TA50 RADIOISOTOPES

OCT-2002

	RAW nCi/L	RAW Total (Ci)		FINAL pCi/l	FINAL Total (Ci)
ALPHA	35.0	36.134e-3		15.0	14.22e-6
Am-241	21.0	21.68e-3		6.0	5.688e-6
As-74	39.0e-3	40.263e-6		21.0	19.908e-6
BETA	LDL*			230.0	218.035e-6
Be-7				LDL*	
Ce-141				LDL*	
Co-56				LDL*	
Co-57				LDL*	
Co-58				LDL*	
Co-60				LDL*	
Cs-134				LDL*	
Cs-137	1.3	1.342e-3		280.0	265.434e-6
Eu-152				LDL*	
I-133				LDL*	
Mn-52				LDL*	
Mn-54				LDL*	
Na-22	9.8e-3	10.117e-6		14.0	13.272e-6
Np-237				LDL*	
Pu-238	19.0	19.615e-3		6.5	6.162e-6
Pu-239	7.4	7.64e-3		3.1	2.939e-6
Ra-226				LDL*	
Ra-228	20.0e-3	20.648e-6		LDL*	
Rb-83				LDL*	
Rb-84				LDL*	
Sc-46				LDL*	
Sc-48				LDL*	
Se-75				LDL*	
Sn-113				LDL*	
Sr-85				LDL*	
Sr-89	LDL*			LDL*	
Sr-90	LDL*			LDL*	
TOTAL PLUTONIUM	26.4	27.255e-3		9.6	9.101e-6
TRITIUM				11000.0	10.428e-3
Th-232	620.0e-6	640.082e-9		40.0e-3	37.919e-9
U-234	26.1e-3	26.945e-6		LDL*	
U-235	1.1e-3	1.136e-6		LDL*	
U-238	45.4e-3	46.871e-6		LDL*	
V-48				LDL*	
Y-88				LDL*	
Zn-65	25.0e-3	25.81e-6		LDL*	
Total Alpha		48.963e-3			14.788e-6

Volume of Flow: Influent = 906,363.0 liters      Final = 947,978.0 liters

\*LDL: Less than Detection Limit.

# TA50 RADIOISOTOPES

NOV-2002

	RAW nCi/L	RAW Total (Ci)		FINAL pCi/l	FINAL Total (Ci)
ALPHA	79.0	77.265e-3		11.0	10.37e-6
Am-241	13.0	12.715e-3		16.0	15.083e-6
As-74	LDL*			18.0	16.969e-6
BETA	4.9	4.792e-3		250.0	235.675e-6
Be-7	LDL*			LDL*	
Ce-141	LDL*			LDL*	
Co-56	LDL*			LDL*	
Co-57	LDL*			LDL*	
Co-58	LDL*			LDL*	
Co-60	LDL*			LDL*	
Cs-134	LDL*			LDL*	
Cs-137	48.0e-3	46.946e-6		110.0	103.697e-6
Eu-152	LDL*			LDL*	
I-133	LDL*			LDL*	
Mn-52	LDL*			LDL*	
Mn-54	LDL*			LDL*	
Na-22	LDL*			50.0	47.135e-6
Np-237	LDL*			LDL*	
Pu-238	43.0	42.056e-3		2.7	2.545e-6
Pu-239	14.0	13.693e-3		1.1	1.037e-6
Ra-226	LDL*			LDL*	
Ra-228	LDL*			LDL*	
Rb-83	LDL*			LDL*	
Rb-84	LDL*			LDL*	
Sc-46	LDL*			LDL*	
Sc-48	LDL*			LDL*	
Se-75	LDL*			LDL*	
Sn-113	LDL*			LDL*	
Sr-85	230.0e-3	224.95e-6		LDL*	
Sr-89	LDL*			LDL*	
Sr-90	27.0e-3	26.407e-6		3.5	3.299e-6
TOTAL PLUTONIUM	LDL*			LDL*	
TRITIUM				6700.0	6.316e-3
Th-232	LDL*			LDL*	
U-234	47.3e-3	46.261e-6		500.0e-3	471.35e-9
U-235	LDL*			LDL*	
U-238	LDL*			LDL*	
V-48	LDL*			LDL*	
Y-88	LDL*			LDL*	
Zn-65	LDL*			LDL*	
Total Alpha		68.509e-3			19.137e-6

Volume of Flow: Influent = 1,350,067.0 liters Final = 942,700.0 liters

\*LDL: Less than Detection Limit.

# TA50 RADIOISOTOPES

DEC-2002

	RAW nCi/L	RAW Total (Ci)		FINAL pCi/l	FINAL Total (Ci)
ALPHA	53.0	42.716e-3		11.0	8.827e-6
Am-241	20.0	16.119e-3		6.0	4.815e-6
As-74	LDL*			37.0	29.692e-6
BETA	LDL*			100.0	80.247e-6
Be-7	LDL*			LDL*	
Ce-141	LDL*			LDL*	
Co-56	LDL*			LDL*	
Co-57	LDL*			LDL*	
Co-58	LDL*			LDL*	
Co-60	LDL*			LDL*	
Cs-134	LDL*			LDL*	
Cs-137	76.0e-3	61.254e-6		95.0	76.235e-6
Eu-152	LDL*			LDL*	
I-133	LDL*			LDL*	
Mn-52	LDL*			LDL*	
Mn-54	LDL*			LDL*	
Na-22	LDL*			9.3	7.463e-6
Np-237	LDL*			LDL*	
Pu-238	8.1	6.528e-3		4.7	3.772e-6
Pu-239	8.1	6.528e-3		2.2	1.765e-6
Pa-226	LDL*			LDL*	
Pa-228	LDL*			LDL*	
Pb-83	LDL*			2.0	1.605e-6
Pb-84	LDL*			LDL*	
Sc-46	LDL*			LDL*	
Sc-48	LDL*			LDL*	
Se-75	LDL*			LDL*	
Sn-113	LDL*			LDL*	
Sr-85	LDL*			LDL*	
Sr-89	38.0e-3	30.627e-6		4.8	3.852e-6
Sr-90	LDL*			LDL*	
TOTAL PLUTONIUM	LDL*			LDL*	
TRITIUM				3600.0	2.889e-3
Th-232	130.0e-6	104.776e-9		LDL*	
U-234	94.0e-3	75.761e-6		1.0	802.473e-9
U-235	LDL*			LDL*	
U-238	LDL*			LDL*	
V-48	LDL*			LDL*	
Y-88	LDL*			LDL*	
Zn-65	LDL*			3.1	2.488e-6
Total Alpha		29.252e-3			11.154e-6

Volume of Flow: Influent = 988,041.0 liters Final = 802,473.0 liters

\*LDL: Less than Detection Limit.

**Appendix D**

**TA-50 RLWTF Monthly Mineral Summary**



# TA50 MINERALS

JAN-2002

	RAW Concentration	Total (KG)		FINAL Concentration	Total (KG)
ALKALINITY-MO*	59.8	55.887		336.0	319.895
ALKALINITY-P*	LDL*			LDL*	
ALUMINUM	0.14	0.131		LDL*	
AMMONIA-N	8.8	8.224		9.6	9.14
ANTIMONY	0.014	0.013		0.018	0.017
ARSENIC	LDL*			LDL*	
BARIUM	0.038	0.036		LDL*	
BERYLLIUM	0.003	0.003		LDL*	
BORON	0.051	0.048		0.087	0.083
CADMIUM	LDL*			LDL*	
CALCIUM	10.8	10.093		5.84	5.56
CHLORIDE	24.0	22.43		32.0	30.466
COBALT	0.001	9.346e-4		LDL*	
COD	91.0	85.046		37.0	35.227
CONDUCTIVITY*	303.0			990.0	
COPPER	0.152	0.142		0.075	0.071
CYANIDE	0.019	0.018		0.02	0.019
FLUORIDE	0.98	0.916		1.04	0.99
HARDNESS*	39.939	37.326		LDL*	
IRON	0.976	0.912		LDL*	
LEAD	0.093	0.087		0.003	0.003
MAGNESIUM	3.15	2.944		LDL*	
MERCURY	0.002	0.002		4.0e-5	3.808e-5
NICKEL	0.386	0.361		0.02	0.019
NITRATE-N	7.45	6.963		1.25	1.19
PERCHLORATE	0.16	0.15		0.11	0.105
PHOSPHORUS	8.1	7.57		0.08	0.076
POTASSIUM	6.07	5.673		11.7	11.139
SELENIUM	0.197	0.184		LDL*	
SILICON	39.0	36.448		24.8	23.611
SILVER	0.009	0.008		LDL*	
SODIUM	25.7	24.018		197.0	187.557
SULFATE	16.8	15.701		115.0	109.488
TDS	70.62	65.999		336.6	320.466
TDS-E	107.0	99.999		510.0	485.555
THALLIUM	3.3e-4	3.084e-4		0.002	0.002
TKN	10.4	9.72		12.6	11.996
TOTAL CATIONS*	2.96			10.83	
TOTAL CHROMIUM	0.044	0.041		0.014	0.013
TOXIC ORGANICS				0.006	0.005
TSS	11.0	10.28		5.0	4.76
URANIUM	0.14	0.131		0.005	0.005
VANADIUM	0.016	0.015		0.013	0.012
ZINC	3.28	3.065		0.465	0.443
pH	7.19			7.93	

Volume of Flow: Influent = 868,026.0 liters Final = 952,068.0 liters

\*Alkalinities and hardness as mg CaCO<sub>3</sub>/l. \*Conductivity as uS/cm. \*Total Cations as meq/l. Otherwise: mg/l

\*LDL: Less than Detection Limit.

# TA50 MINERALS

FEB-2002

	RAW Concentration	Total (KG)		FINAL Concentration	Total (KG)
ALKALINITY-MO*	59.8	42.188		199.0	115.14
ALKALINITY-P*	LDL*			LDL*	
ALUMINUM	1.32	0.931		0.06	0.035
AMMONIA-N	9.5	6.702		6.2	3.587
ARSENIC	LDL*			LDL*	
BARUM	0.034	0.024		0.001	5.786e-4
BERYLLIUM	LDL*			0.001	5.786e-4
BORON	2.69	1.898		LDL*	
CADMIUM	0.008	0.006		LDL*	
CALCIUM	11.0	7.76		4.74	2.743
CHLORIDE	27.0	19.048		46.5	26.905
COBALT	0.009	0.006		LDL*	
COD	81.0	57.144		19.0	10.993
CONDUCTIVITY*	298.0			624.0	
COPPER	0.792	0.559		0.038	0.022
CYANIDE	0.04	0.028		0.06	0.035
FLUORIDE	1.1	0.776		0.51	0.295
HARDNESS*	40.48	28.558		12.359	7.151
IRON	2.97	2.095		0.056	0.032
LEAD	0.198	0.14		0.008	0.005
MAGNESIUM	3.16	2.229		0.127	0.073
MERCURY	0.002	0.001		3.1e-4	1.794e-4
NICKEL	0.364	0.257		0.018	0.01
NITRATE-N	4.1	2.892		0.78	0.451
PERCHLORATE	1.09	0.769		0.053	0.031
PHOSPHORUS	5.6	3.951		0.03	0.017
POTASSIUM	6.7	4.727		30.8	17.821
SELENIUM	0.141	0.099		LDL*	
SILICON	65.0	45.856		20.5	11.861
SILVER	LDL*			LDL*	
SODIUM	24.4	17.214		120.0	69.431
SULFATE	32.0	22.575		52.0	30.087
TDS	92.4	65.186		165.0	95.468
TDS-E	140.0	98.767		250.0	144.648
TKN	14.3	10.088		7.2	4.166
TOTAL CATIONS*	2.95			6.53	
TOTAL CHROMIUM	0.095	0.067		0.009	0.005
TOXIC ORGANICS				0.004	0.002
TSS	16.0	11.288		6.0	3.472
VANADIUM	LDL*			0.016	0.009
ZINC	0.23	0.162		0.012	0.007
pH	7.03			8.21	

Volume of Flow:    Influent = 787,405.0 liters    Final = 578,594.0 liters

\*Alkalinities and hardness as mg CaCO3/l.    \*Conductivity as uS/cm.    \*Total Cations as meq/l.    Otherwise: mg/l

\*LDL: Less than Detection Limit.

# TA50 MINERALS

MAR-2002

	RAW Concentration	Total (KG)		FINAL Concentration	Total (KG)
ALKALINITY-MO*	58.6	40.723		181.0	118.972
ALKALINITY-P*	LDL*			LDL*	
ALUMINIUM	2.9	2.015		0.18	0.118
AMMONIA-N	14.0	9.729		7.4	4.864
ANTIMONY	0.002	0.001		0.002	0.001
ARSENIC	0.017	0.012		0.015	0.01
BARIUM	0.021	0.015		LDL*	
BERYLLIUM	LDL*			LDL*	
BORON	2.91	2.022		3.94	2.59
CADMIUM	LDL*			LDL*	
CALCIUM	9.82	6.824		6.0	3.944
CHLORIDE	27.0	18.763		25.0	16.433
COBALT	LDL*			LDL*	
COD	64.0	44.475		21.0	13.803
CONDUCTIVITY*	403.0			481.0	
COPPER	0.303	0.211		0.067	0.044
CYANIDE	LDL*			0.04	0.026
FLUORIDE	0.84	0.584		0.39	0.256
HARDNESS*	36.998	25.711		15.064	9.902
IRON	0.927	0.644		0.059	0.039
LEAD	0.045	0.031		LDL*	
MAGNESIUM	3.03	2.108		0.02	0.013
MERCURY	0.005	0.003		6.0e-5	3.944e-5
NICKEL	0.096	0.067		0.017	0.011
NITRATE-N	18.0	12.509		0.73	0.48
NITRITE-N	0.55	0.382		2.93	1.926
PERCHLORATE	0.196	0.136		0.06	0.039
PHOSPHORUS	2.8	1.946		0.02	0.013
POTASSIUM	6.7	4.656		16.0	10.517
SELENIUM	0.024	0.017		LDL*	
SILICON	11.8	8.2		12.4	8.151
SILVER	LDL*			LDL*	
SODIUM	41.0	28.492		101.0	66.388
SULFATE	17.0	11.814		44.0	28.921
TDS	163.02	113.287		205.92	135.352
TDS-E	247.0	171.647		312.0	205.079
THALLIUM	LDL*			LDL*	
THORIUM	LDL*			LDL*	
TKN	16.7	11.605		8.9	5.85
TOTAL CATIONS*	3.73			5.3	
TOTAL CHROMIUM	0.02	0.014		0.002	0.001
TOXIC ORGANICS				0.004	0.003
TSS	144.0	100.07		LDL*	
URANIUM	0.214	0.149		LDL*	
VANADIUM	0.003	0.002		0.004	0.003
ZINC	0.1	0.069		0.029	0.019
pH	7.18			8.26	

Volume of Flow: Influent = 821,278.0 liters Final = 657,306.0 liters

\*Alkalinities and hardness as mg CaCO<sub>3</sub>/l. \*Conductivity as uS/cm. \*Total Cations as meq/l. Otherwise: mg/l

\*LDL: Less than Detection Limit.

# TA50 MINERALS

APR-2002

	FAW Concentration	Total (KG)		FINAL Concentration	Total (KG)
ALKALINITY-MO*	51.9	45.958		47.4	34.685
ALKALINITY-P*	LDL*			LDL*	
ALUMINUM	0.33	0.292		LDL*	
AMMONIA-N	7.81	6.916		4.16	3.044
ANTIMONY	0.003	0.003		0.001	7.318e-4
ARSENIC	LDL*			LDL*	
BARIUM	0.015	0.013		LDL*	
BERYLLIUM	LDL*			LDL*	
BORON	0.063	0.056		0.054	0.04
CADMIUM	LDL*			LDL*	
CALCIUM	11.0	9.741		1.7	1.244
CHLORIDE	28.0	24.794		3.87	2.832
COBALT	LDL*			LDL*	
COD	127.0	112.459		12.0	8.781
CONDUCTIVITY*	193.0			134.0	
COPPER	0.16	0.142		LDL*	
CYANIDE	0.04	0.035		0.04	0.029
FLUORIDE	0.98	0.868		0.03	0.022
HARDNESS*	41.056	36.355		LDL*	
IRON	1.7	1.505		LDL*	
LEAD	0.045	0.04		LDL*	
MAGNESIUM	3.3	2.922		LDL*	
MERCURY	0.002	0.002		LDL*	
NICKEL	0.12	0.106		LDL*	
NITRATE-N	4.99	4.419		0.36	0.263
NITRITE-N	0.35	0.31		0.45	0.329
PERCHLORATE	0.119	0.105		LDL*	
PHOSPHORUS	4.0	3.542		0.1	0.073
POTASSIUM	7.0	6.199		1.7	1.244
SELENIUM	LDL*			LDL*	
SILICON	37.0	32.764		1.06	0.776
SILVER	0.02	0.018		LDL*	
SODIUM	28.0	24.794		23.0	16.83
SULFATE	18.0	15.939		15.0	10.976
TDS	LDL*			LDL*	
THALLIUM	LDL*			LDL*	
THORIUM	LDL*			LDL*	
TKN	10.5	9.298		6.25	4.573
TOTAL CATIONS*	2.65			1.33	
TOTAL CHROMIUM	0.03	0.027		LDL*	
TOXIC ORGANICS				0.002	0.002
TSS	LDL*			LDL*	
URANIUM	0.111	0.098		LDL*	
VANADIUM	0.016	0.014		LDL*	
ZINC	0.12	0.106		LDL*	
pH	7.34			8.16	

Volume of Flow: Influent = 826,666.0 liters Final = 731,754.0 liters

\*Alkalinities and hardness as mg CaCO3/l. \*Conductivity as uS/cm \*Total Cations as meq/l. Otherwise: mg/l

\*LDL: Less than Detection Limit.

# TA50 MINERALS

MAY-2002

	RAW Concentration	Total (KG)		FINAL Concentration	Total (KG)
ALKALINITY-MO*	52.9	61.362		67.5	68.906
ALKALINITY-P*	LDL*			LDL*	
ALUMINUM	0.41	0.476		LDL*	
AMMONIA-N	3.55	4.118		3.65	3.726
ANTIMONY	0.004	0.005		0.001	0.001
ARSENIC	LDL*			LDL*	
BARIUM	0.01	0.012		LDL*	
BERYLLIUM	LDL*			LDL*	
BORON	0.045	0.052		0.03	0.031
CADMIUM	LDL*			LDL*	
CALCIUM	10.0	11.6		10.2	10.413
CHLORIDE	21.0	24.359		5.4	5.513
COBALT	LDL*			LDL*	
COB	54.0	62.638		10.0	10.208
CONDUCTIVITY*	240.0			190.0	
COPPER	0.3	0.348		LDL*	
CYANIDE	LDL*			LDL*	
FLUORIDE	0.69	0.8		0.07	0.071
HARDNESS*	37.324	43.294		38.235	39.032
IRON	2.1	2.436		0.03	0.031
LEAD	0.06	0.07		LDL*	
MAGNESIUM	3.0	3.48		3.1	3.165
MERCURY	0.006	0.007		4.0e-5	4.083e-5
NICKEL	0.11	0.128		LDL*	
NITRATE-N	2.55	2.958		0.06	0.061
NITRITE-N	0.42	0.487		0.04	0.041
PERCHLORATE	0.152	0.176		LDL*	
PHOSPHORUS	3.22	3.735		0.04	0.041
POTASSIUM	4.2	4.872		4.0	4.083
SELENIUM	LDL*			LDL*	
SILICON	38.0	44.078		2.0	2.042
SILVER	0.06	0.07		LDL*	
SODIUM	22.0	25.519		21.0	21.438
SULFATE	21.0	24.359		25.0	25.521
TDS	188.0	218.072		66.0	67.375
THALLIUM	LDL*			5.3e-4	5.41e-4
TKN	5.14	5.962		2.6	2.654
TOTAL CATIONS*	2.36			2.0	
TOTAL CHROMIUM	0.03	0.035		LDL*	
TOXIC ORGANICS				0.002	0.002
TSS	35.0	40.599		LDL*	
URANIUM	0.335	0.389		LDL*	
VANADIUM	LDL*			LDL*	
ZINC	0.15	0.174		LDL*	
pH	6.8			7.66	

Volume of Flow: Influent = 1,066,196.0 liters Final = 1,020,837.0 liters

\*Alkalinities and hardness as mg CaCO3/l. \*Conductivity as uS/cm. \*Total Cations as meq/l. Otherwise: mg/l

\*LDL: Less than Detection Limit.

# TA50 MINERALS

JUN-2002

	RAW Concentration	Total (KG)		FINAL Concentration	Total (KG)
ALKALINITY-MO*	52.9	76.811		93.8	109.305
ALKALINITY-P*	LDL*			LDL*	
ALUMINUM	1.26	1.83		0.042	0.049
AMMONIA-N	4.0	5.808		6.1	7.108
ANTIMONY	0.012	0.017		0.013	0.015
ARSENIC	LDL*			LDL*	
BARIUM	0.055	0.08		0.002	0.002
BERYLLIUM	LDL*			LDL*	
BORON	0.167	0.242		0.16	0.186
CADMIUM	0.004	0.006		LDL*	
CALCIUM	12.0	17.424		3.0	3.496
CHLORIDE	25.0	36.3		14.0	16.314
COBALT	0.004	0.006		0.001	0.001
COD	103.0	149.557		LDL*	
CONDUCTIVITY*	390.0			390.0	
COPPER	0.432	0.627		0.025	0.029
CYANIDE	LDL*			LDL*	
FLUORIDE	0.66	0.958		0.21	0.245
HARDNESS*	46.024	66.827		8.356	9.737
IRON	2.86	4.153		0.08	0.093
LEAD	0.16	0.232		LDL*	
MAGNESIUM	3.9	5.663		0.21	0.245
MERCURY	0.009	0.013		6.0e-5	6.992e-5
NICKEL	0.22	0.319		LDL*	
NITRATE-N	5.16	7.492		0.15	0.175
NITRITE-N	0.19	0.276		0.5	0.583
PERCHLORATE	0.164	0.238		LDL*	
PHOSPHORUS	5.5	7.986		0.05	0.058
POTASSIUM	6.2	9.002		5.3	6.176
SELENIUM	LDL*			LDL*	
SILICON	37.0	53.724		5.8	6.759
SILVER	0.105	0.152		0.001	0.001
SODIUM	55.0	79.86		66.0	76.91
SULFATE	56.0	81.312		59.0	68.752
TDS	244.0	354.289		144.0	167.803
THALLIUM	LDL*			LDL*	
THORIUM	5.0e-13	7.26e-13			
TKN	5.15	7.478		7.78	9.066
TOTAL CATIONS*	3.6			3.66	
TOTAL CHROMIUM	0.098	0.142		LDL*	
TOXIC ORGANICS				0.003	0.004
TSS	64.0	92.928		LDL*	
URANIUM	0.286	0.415		LDL*	
VANADIUM	0.03	0.044		LDL*	
ZINC	0.19	0.276		LDL*	
pH	7.03			7.94	

Volume of Flow: Influent = 1,306,290.0 liters Final = 1,165,296.0 liters

\*Alkalinities and hardness as mg CaCO3/l. \*Conductivity as uS/cm. \*Total Cations as mg/l. Otherwise: mg/l

\*LDL: Less than Detection Limit.

02107

# TA50 MINERALS

JUL-2002

	RAW Concentration	Total (KG)		FINAL Concentration	Total (KG)
ALKALINITY-MO*	40.7	60.122		109.0	159.32
ALKALINITY-P*	LDL*			LDL*	
ALUMINUM	0.59	0.872		0.014	0.02
AMMONIA-N	2.16	3.191		4.2	6.139
ANTIMONY	0.009	0.013		0.006	0.009
ARSENIC	LDL*			LDL*	
BARIUM	0.034	0.05		LDL*	
BERYLLIUM	LDL*			LDL*	
BORON	0.05	0.074		LDL*	
CADMIUM	0.004	0.006		LDL*	
CALCIUM	11.0	16.249		0.75	1.096
CHLORIDE	18.0	26.59		12.5	18.271
COBALT	LDL*			LDL*	
COD	56.0	82.723		LDL*	
CONDUCTIVITY*	230.0			340.0	
COPPER	1.05	1.551		0.023	0.034
CYANIDE	0.009	0.013		0.003	0.004
FLUORIDE	0.25	0.369		0.18	0.263
HARDNESS*	40.233	59.432		1.972	2.882
IRON	1.21	1.787		0.02	0.029
LEAD	0.114	0.168		LDL*	
MAGNESIUM	3.1	4.579		0.024	0.035
MERCURY	0.003	0.004		LDL*	
NICKEL	0.06	0.089		LDL*	
NITRATE-N	5.0	7.386		0.71	1.038
NITRITE-N	0.35	0.517		0.66	0.965
PERCHLORATE	0.08	0.118		LDL*	
PHOSPHORUS	0.042	0.062		1.02	1.491
POTASSIUM	3.5	5.17		3.5	5.116
SELENIUM	LDL*			LDL*	
SILICON	35.0	51.702		6.1	8.916
SILVER	0.03	0.044		LDL*	
SODIUM	20.0	29.544		63.0	92.084
SULFATE	12.0	17.726		16.2	23.679
TDS	148.0	218.626		130.0	190.015
THALLIUM	LDL*			LDL*	
THORIUM	1.6e-13	2.364e-13			
TKN	3.46	5.111		3.92	5.73
TOTAL CATIONS*	2.05			3.34	
TOTAL CHROMIUM	0.032	0.047		LDL*	
TOXIC ORGANICS				7.0e-4	0.001
TSS	7.6	11.227		LDL*	
URANIUM	0.198	0.292		LDL*	
VANADIUM	0.023	0.034		0.011	0.016
ZINC	0.21	0.31		LDL*	
pH	6.63			7.8	

Volume of Flow: Influent = 1,354,195.0 liters Final = 1,461,654.0 liters

\*Alkalinities and hardness as mg CaCO3/l. \*Conductivity as uS/cm \*Total Cations as meq/l. Otherwise: mg/l

\*LDL: Less than Detection Limit.

# TA50 MINERALS

AUG-2002

	RAW Concentration	Total (KG)		FINAL Concentration	Total (KG)
ALKALINITY-MO*	51.0	51.644		165.0	144.604
ALKALINITY-P*	LDL*			LDL*	
ALUMINIUM	0.78	0.79		0.048	0.042
AMMONIA-N	2.68	2.714		2.81	2.463
ARSENIC	LDL*			LDL*	
BARIUM	0.037	0.037		LDL*	
BERYLLIUM	LDL*			LDL*	
BORON	0.134	0.136		0.071	0.062
CADMIUM	0.005	0.005		LDL*	
CALCIUM	12.0	12.151		1.7	1.49
CHLORIDE	21.0	21.265		19.0	16.651
COBALT	LDL*			LDL*	
COD	48.0	48.606		14.0	12.269
CONDUCTIVITY*	270.0			580.0	
COPPER	0.41	0.415		0.044	0.039
CYANIDE	0.025	0.025		0.005	0.004
FLUORIDE	0.54	0.547		0.37	0.324
HARDNESS*	46.024	46.605		4.352	3.814
IRON	0.968	0.98		0.018	0.016
LEAD	0.08	0.081		LDL*	
MAGNESIUM	3.9	3.949		0.026	0.023
MERCURY	0.005	0.005		4.0e-5	3.506e-5
NICKEL	0.083	0.084		LDL*	
NITRATE-N	4.83	4.891		0.2	0.175
NITRITE-N	0.26	0.263		1.74	1.525
PERCHLORATE	0.216	0.219		LDL*	
PHOSPHORUS	3.1	3.139		0.201	0.176
POTASSIUM	3.8	3.848		4.4	3.856
SELENIUM	LDL*			LDL*	
SILICON	33.0	33.417		12.0	10.517
SILVER	0.104	0.105		0.086	0.075
SODIUM	29.0	29.366		124.0	108.672
SULFATE	17.0	17.215		76.0	66.606
TDS	110.0	111.389		208.0	182.289
THORIUM	1.1e-12	1.114e-12		LDL*	
TKN	5.0	5.063		3.2	2.804
TOTAL CATIONS*	2.52			5.73	
TOTAL CHROMIUM	0.037	0.037		LDL*	
TOXIC ORGANICS				0.003	0.003
TSS	20.0	20.252		LDL*	
URANIUM	0.143	0.145		LDL*	
VANADIUM	0.01	0.01		LDL*	
ZINC	0.13	0.132		LDL*	
pH	6.73			7.87	

Volume of Flow: Influent = 984,096.0 liters Final = 876,390.0 liters

\*Alkalinities and hardness as mg CaCO<sub>3</sub>/l. \*Conductivity as uS/cm. \*Total Cations as meq/l. Otherwise: mg/l

\*LDL: Less than Detection Limit.



# TA50 MINERALS

SEP-2002

	RAW Concentration	Total (KG)		FINAL Concentration	Total (KG)
ALKALINITY-MO*	48.8	41.296		152.0	132.719
ALKALINITY-P*	LDL*			LDL*	
ALUMINIUM	2.25	1.904		0.012	0.01
AMMONIA-N	1.6	1.354		2.86	2.497
ARSENIC	LDL*			LDL*	
BARIUM	0.08	0.068		LDL*	
BERYLLIUM	0.005	0.004		LDL*	
BORON	0.122	0.103		0.114	0.1
CADMIUM	0.008	0.007		LDL*	
CALCIUM	13.6	11.509		1.6	1.397
CHLORIDE	57.0	48.236		26.0	22.702
COBALT	LDL*			LDL*	
COD	270.0	228.485		13.0	11.351
CONDUCTIVITY*	380.0			520.0	
COPPER	1.73	1.464		0.038	0.033
CYANIDE	LDL*			LDL*	
FLUORIDE	0.88	0.745		0.46	0.402
HARDNESS*	79.257	67.07		4.242	3.704
IRON	5.3	4.485		0.02	0.017
LEAD	0.31	0.262		LDL*	
MAGNESIUM	11.0	9.309		0.06	0.052
MERCURY	0.025	0.021		1.0e-4	8.732e-5
NICKEL	0.22	0.186		LDL*	
NITRATE-N	3.56	3.013		0.32	0.279
NITRITE-N	0.4	0.338		1.99	1.738
PERCHLORATE	0.33	0.279		LDL*	
PHOSPHORUS	4.96	4.197		0.25	0.218
POTASSIUM	12.0	10.155		6.2	5.414
SELENIUM	LDL*			LDL*	
SILICON	36.0	30.465		9.0	7.858
SILVER	0.05	0.042		LDL*	
SODIUM	36.0	30.465		115.0	100.413
SULFATE	20.0	16.925		56.0	48.897
TDS	142.0	120.166		140.0	122.241
THORIUM	5.2e-13	4.4e-13		LDL*	
TKN	6.4	5.416		3.5	3.056
TOTAL CATIONS*	3.46			5.07	
TOTAL CHROMIUM	0.14	0.118		LDL*	
TOXIC ORGANICS				0.004	0.003
TSS	210.0	177.71		LDL*	
URANIUM	1.04	0.88		LDL*	
VANADIUM	0.03	0.025		LDL*	
ZINC	0.25	0.212		0.011	0.01
pH	6.01			7.37	

Volume of Flow: Influent = 727,429.0 liters Final = 873,153.0 liters

\*Alkalinities and hardness as mg CaCO<sub>3</sub>/l. \*Conductivity as uS/cm. \*Total Cations as meq/l. Otherwise: mg/l

\*LDL: Less than Detection Limit.

# TA50 MINERALS

OCT-2002

	RAW Concentration	Total (KG)		FINAL Concentration	Total (KG)
ALKALINITY-MO*	69.1	71.338		334.0	316.625
ALKALINITY-P*	LDL*			LDL*	
ALUMINUM	0.85	0.878		0.035	0.033
AMMONIA-N	2.09	2.158		3.89	3.688
ARSENIC	LDL*			LDL*	
BARIUM	0.045	0.046		LDL*	
BERYLLIUM	0.001	0.001		LDL*	
BORON	0.08	0.083		0.117	0.111
CADMIUM	0.005	0.005		LDL*	
CALCIUM	16.0	16.518		2.71	2.569
CHLORIDE	23.0	23.745		33.0	31.283
COBALT	0.001	0.001		0.001	9.48e-4
COD	107.0	110.466		21.0	19.908
CONDUCTIVITY*	260.0			940.0	
COPPER	0.283	0.292		0.076	0.072
CYANIDE	LDL*			LDL*	
FLUORIDE	0.5	0.516		0.85	0.806
HARDNESS*	55.189	56.977		7.121	6.751
IRON	2.84	2.932		0.034	0.032
LEAD	0.067	0.069		LDL*	
MAGNESIUM	3.7	3.82		0.086	0.082
MERCURY	0.011	0.011		1.9e-4	1.801e-4
NICKEL	0.053	0.055		0.018	0.017
NITRATE-N	2.78	2.87		0.29	0.275
NITRITE-N	0.012	0.012		1.39	1.318
PERCHLORATE	0.118	0.122		LDL*	
PHOSPHORUS	3.14	3.242		0.23	0.218
POTASSIUM	4.3	4.439		12.0	11.376
SELENIUM	LDL*			LDL*	
SILICON	36.0	37.166		17.0	16.116
SILVER	0.042	0.043		0.002	0.002
SODIUM	29.0	29.939		220.0	208.555
SULFATE	15.0	15.486		123.0	116.601
TDS	290.0	299.393		580.0	549.827
THORIUM	6.2e-13	6.401e-13		4.0e-14	3.792e-14
TKN	3.56	3.675		5.1	4.835
TOTAL CATIONS*	2.76			10.7	
TOTAL CHROMIUM	0.035	0.036		0.003	0.003
TOXIC ORGANICS				0.005	0.005
TSS	21.0	21.68		LDL*	
URANIUM	0.136	0.14		LDL*	
VANADIUM	0.012	0.012		LDL*	
ZINC	0.342	0.353		0.06	0.057
pH	6.41			7.59	

Volume of Flow: Influent = 906,363.0 liters Final = 947,978.0 liters

\*Alkalinities and hardness as mg CaCO<sub>3</sub>/l. \*Conductivity as uS/cm. \*Total Cations as meq/l. Otherwise: mg/l

\*LDL: Less than Detection Limit.

# TA50 MINERALS

NOV-2002

	RAW Concentration	Total (KG)		FINAL Concentration	Total (KG)
ALKALINITY-MO*	68.0	66.507		456.0	429.871
ALKALINITY-P*	LDL*			LDL*	
ALUMINIUM	0.698	0.683		0.05	0.047
AMMONIA-N	4.87	4.763		10.8	10.181
ARSENIC	LDL*			LDL*	
BARIUM	0.033	0.032		LDL*	
BERYLLIUM	0.002	0.002		LDL*	
BORON	0.08	0.078		0.101	0.095
CADMIUM	0.003	0.003		LDL*	
CALCIUM	14.0	13.693		2.0	1.885
CHLORIDE	17.0	16.627		36.0	33.937
COBALT	0.001	9.78e-4		0.001	9.427e-4
COD	42.0	41.078		8.0	7.542
CONDUCTIVITY*	290.0			1200.0	
COPPER	0.285	0.279		0.075	0.071
CYANIDE	0.006	0.006		0.005	0.005
FLUORIDE	0.36	0.352		0.76	0.716
HARDNESS*	48.63	47.562		5.241	4.941
IRON	2.21	2.161		0.04	0.038
LEAD	0.06	0.059		LDL*	
MAGNESIUM	3.32	3.247		0.06	0.057
MERCURY	0.008	0.008		8.0e-5	7.542e-5
NICKEL	1.1	1.076		0.02	0.019
NITRATE-N	5.29	5.174		0.14	0.132
NITRITE-N	0.53	0.518		1.03	0.971
PERCHLORATE	0.034	0.033		LDL*	
PHOSPHORUS	3.23	3.159		0.194	0.183
POTASSIUM	5.65	5.526		12.0	11.312
SELENIUM	LDL*			LDL*	
SILICON	35.0	34.232		15.0	14.14
SILVER	0.004	0.004		0.002	0.002
SODIUM	30.0	29.341		270.0	254.529
SULFATE	22.0	21.517		149.0	140.462
TDS	220.0	215.17		690.0	650.463
THORIUM	5.0e-14	4.89e-14			
TKN	10.2	9.976		2.23	2.102
TOTAL CATIONS*	2.84			13.2	
TOTAL CHROMIUM	0.057	0.056		0.003	0.003
TOXIC ORGANICS				0.002	0.002
TSS	20.0	19.561		4.4	4.148
URANIUM	0.178	0.174		1.7e-4	1.603e-4
VANADIUM	0.01	0.01		LDL*	
ZINC	0.22	0.215		LDL*	
pH	6.67			8.05	

Volume of Flow:    Influent = 1,350,067.0 liters    Final = 942,700.0 liters

\*Alkalinities and hardness as mg CaCO<sub>3</sub>/l.    \*Conductivity as uS/cm.    \*Total Cations as meq/l.    Otherwise: mg/l

\*LDL: Less than Detection Limit.

# TA50 MINERALS

DEC-2002

	RAW Concentration	Total (KG)		FINAL Concentration	Total (KG)
ALKALINITY-MO*	85.8	69.152		470.0	377.162
ALKALINITY-P*	LDL*			LDL*	
ALUMINIUM	0.697	0.562		0.023	0.018
AMMONIA-N	4.05	3.264		7.08	5.682
ARSENIC	LDL*			LDL*	
BARIUM	0.03	0.024		LDL*	
BERYLLIUM	0.004	0.003		LDL*	
BORON	0.07	0.056		0.078	0.063
CADMIUM	LDL*			LDL*	
CALCIUM	17.0	13.701		3.8	3.049
CHLORIDE	21.0	16.925		65.0	52.181
COBALT	LDL*			LDL*	
COD	74.0	59.642		56.0	44.938
CONDUCTIVITY*	410.0			1360.0	
COPPER	0.19	0.153		0.07	0.056
CYANIDE	0.043	0.035		0.005	0.004
FLUORIDE	0.84	0.677		0.85	0.682
HARDNESS*	63.039	50.808		9.736	7.813
IRON	1.3	1.048		0.03	0.024
LEAD	0.052	0.042		LDL*	
MAGNESIUM	5.0	4.03		0.06	0.048
MERCURY	0.002	0.002		8.0e-5	6.42e-5
NICKEL	0.06	0.048		0.02	0.016
NITRATE-N	5.68	4.578		0.25	0.201
NITRITE-N	0.39	0.314		1.8	1.444
PERCHLORATE	0.107	0.086		LDL*	
PHOSPHORUS	4.98	4.014		0.24	0.193
POTASSIUM	5.7	4.594		10.0	8.025
SELENIUM	LDL*			LDL*	
SILICON	36.0	29.015		19.0	15.247
SILVER	0.006	0.005		0.002	0.002
SODIUM	51.0	41.104		311.0	249.569
SULFATE	51.0	41.104		119.0	95.494
TDS	250.0	201.492		750.0	601.855
TKN	6.3	5.078		8.7	6.982
TOTAL CATIONS*	3.94			14.3	
TOTAL CHROMIUM	0.03	0.024		0.005	0.004
TOXIC ORGANICS				0.004	0.003
TSS	13.0	10.478		8.8	7.062
URANIUM	0.068	0.055		4.4e-4	3.531e-4
VANADIUM	0.02	0.016		0.01	0.008
ZINC	0.12	0.097		LDL*	
pH	6.95			7.67	

Volume of Flow: Influent = 988,041.0 liters Final = 802,473.0 liters

\*Alkalinities and hardness as mg CaCO3/l. \*Conductivity as uS/cm. \*Total Cations as meq/l. Otherwise: mg/l

\*LDL: Less than Detection Limit.

: 02113

**Appendix E**

**TA-50 Plant Feed VOC Results by Sample**

**Appendix F**

**TA-50 Plant Feed VOC Results by Species**

**Appendix G**

**TA-50 Plant Feed SVOC Results by Sample**

**Appendix H**

**TA-50 Plant Feed SVOC Results by Species**

RADIOACTIVE LIQUID WASTE  
TREATMENT FACILITY  
VOC results by sample for TA50 Plant Feed  
01-JAN-2002 - 31-DEC-2002

Sample Date	Sample Number	Species	Concentration (mg/l)	Uncertainty (mg/l)
03-JAN-2002	P0102.03	CHLOROFORM	4.4e-4	4.4e-5
03-JAN-2002	P0102.03	METHYLENE CHLORIDE	0.001	1.4e-4
07-JAN-2002	P0102.07	1,2,4-TRIMETHYLBENZENE	5.2e-4	5.2e-5
07-JAN-2002	P0102.07	2-BUTANONE	0.006	6.3e-4
07-JAN-2002	P0102.07	4-METHYL-2-PENTANONE	0.003	3.0e-4
07-JAN-2002	P0102.07	ACETONE	0.25	0.025
07-JAN-2002	P0102.07	BROMOMETHANE	0.002	2.0e-4
07-JAN-2002	P0102.07	CHLOROFORM	4.9e-4	4.9e-5
07-JAN-2002	P0102.07	CHLOROMETHANE	7.8e-4	7.8e-5
07-JAN-2002	P0102.07	IODOMETHANE	0.005	5.4e-4
14-JAN-2002	P0102.14	ACETONE	3.3	0.33
14-JAN-2002	P0102.14	CHLOROFORM	0.066	0.009
14-JAN-2002	P0102.14	METHYLENE CHLORIDE	0.27	0.027
22-JAN-2002	P0102.22	1,2,4-TRIMETHYLBENZENE	3.7e-4	3.7e-5
22-JAN-2002	P0102.22	2-BUTANONE	0.011	0.001
22-JAN-2002	P0102.22	2-HEXANONE	0.008	7.6e-4
22-JAN-2002	P0102.22	4-METHYL-2-PENTANONE	0.002	1.7e-4
22-JAN-2002	P0102.22	ACETONE	0.51	0.051
22-JAN-2002	P0102.22	BROMOMETHANE	7.3e-4	7.3e-5
22-JAN-2002	P0102.22	CHLOROFORM	0.001	1.2e-4
22-JAN-2002	P0102.22	IODOMETHANE	0.002	1.5e-4
28-JAN-2002	P0102.28	1,2,4-TRIMETHYLBENZENE	9.9e-4	9.9e-5
28-JAN-2002	P0102.28	2-BUTANONE	0.004	4.2e-4
28-JAN-2002	P0102.28	4-METHYL-2-PENTANONE	0.003	2.6e-4
28-JAN-2002	P0102.28	ACETONE	1.2	0.12
28-JAN-2002	P0102.28	CHLOROFORM	0.001	1.2e-4
07-FEB-2002	P0202.07	4-METHYL-2-PENTANONE	0.004	4.3e-4
07-FEB-2002	P0202.07	ACETONE	1.1	0.11
07-FEB-2002	P0202.07	CHLOROFORM	0.003	3.1e-4
07-FEB-2002	P0202.07	METHYLENE CHLORIDE	0.003	2.9e-4
12-FEB-2002	P0202.12	1,2,4-TRIMETHYLBENZENE	0.001	1.0e-4
12-FEB-2002	P0202.12	2-BUTANONE	0.004	3.5e-4
12-FEB-2002	P0202.12	4-METHYL-2-PENTANONE	0.002	2.3e-4
12-FEB-2002	P0202.12	ACETONE	0.83	0.083
12-FEB-2002	P0202.12	CHLOROFORM	0.005	5.1e-4
12-FEB-2002	P0202.12	CHLOROMETHANE	2.3e-4	2.3e-5
12-FEB-2002	P0202.12	METHYLENE CHLORIDE	2.5e-4	2.5e-5
21-FEB-2002	P0202.21	4-METHYL-2-PENTANONE	0.005	4.6e-4
21-FEB-2002	P0202.21	ACETONE	1.8	0.18
21-FEB-2002	P0202.21	CHLOROFORM	0.009	8.6e-4
21-FEB-2002	P0202.21	METHYLENE CHLORIDE	0.013	0.001
26-FEB-2002	P0202.26	ACETONE	0.84	0.084
26-FEB-2002	P0202.26	CHLOROFORM	0.003	3.0e-4
26-FEB-2002	P0202.26	METHYLENE CHLORIDE	0.003	3.0e-4
26-FEB-2002	P0202.26	TOLUENE	0.002	2.0e-4
04-MAR-2002	P0302.04	ACETONE	0.87	0.087
04-MAR-2002	P0302.04	CHLOROFORM	0.002	1.9e-4
04-MAR-2002	P0302.04	METHYLENE CHLORIDE	0.002	1.5e-4
04-MAR-2002	P0302.04	TOLUENE	0.001	1.2e-4
25-MAR-2002	P0302.25	ACETONE	0.26	0.026

RADIOACTIVE LIQUID WASTE  
TREATMENT FACILITY

VOC results by sample for TA50 Plant Feed  
01-JAN-2002 - 31-DEC-2002

Sample Date	Sample Number	Species	Concentration (mg/l)	Uncertainty (mg/l)
25-MAR-2002	P0302.25	CHLOROFORM	0.003	2.6e-4
25-MAR-2002	P0302.25	METHYLENE CHLORIDE	0.005	5.2e-4
02-APR-2002	P0402.02	1,2,4-TRIMETHYLBENZENE	0.001	1.4e-4
02-APR-2002	P0402.02	2-BUTANONE	0.005	5.3e-4
02-APR-2002	P0402.02	4-METHYL-2-PENTANONE	0.015	0.002
02-APR-2002	P0402.02	ACETONE	0.27	0.027
02-APR-2002	P0402.02	BROMODICHLOROMETHANE	2.3e-4	2.3e-5
02-APR-2002	P0402.02	CHLOROFORM	0.002	1.7e-4
02-APR-2002	P0402.02	CHLOROMETHANE	2.5e-4	2.5e-5
02-APR-2002	P0402.02	METHYLENE CHLORIDE	0.003	3.0e-4
09-APR-2002	P0402.09	1,2,4-TRIMETHYLBENZENE	0.002	1.7e-4
09-APR-2002	P0402.09	2-BUTANONE	0.027	0.003
09-APR-2002	P0402.09	4-METHYL-2-PENTANONE	0.015	0.002
09-APR-2002	P0402.09	ACETONE	1.2	0.12
09-APR-2002	P0402.09	CHLOROFORM	0.002	2.3e-4
09-APR-2002	P0402.09	METHYLENE CHLORIDE	4.8e-4	4.8e-5
15-APR-2002	P0402.15	1,2,4-TRIMETHYLBENZENE	7.5e-4	7.5e-5
15-APR-2002	P0402.15	2-BUTANONE	0.012	0.001
15-APR-2002	P0402.15	4-METHYL-2-PENTANONE	0.004	4.3e-4
15-APR-2002	P0402.15	ACETONE	0.36	0.036
15-APR-2002	P0402.15	BROMOMETHANE	0.001	1.3e-4
15-APR-2002	P0402.15	CARBON DISULFIDE	5.3e-4	5.3e-5
15-APR-2002	P0402.15	CHLOROFORM	0.001	1.4e-4
15-APR-2002	P0402.15	CHLOROMETHANE	0.002	2.2e-4
15-APR-2002	P0402.15	IODOMETHANE	0.004	4.2e-4
15-APR-2002	P0402.15	METHYLENE CHLORIDE	4.8e-4	4.8e-5
15-APR-2002	P0402.15	TRICHLOROETHENE	6.0e-4	6.0e-5
22-APR-2002	P0402.22	1,2,4-TRIMETHYLBENZENE	9.4e-4	9.4e-5
22-APR-2002	P0402.22	2-BUTANONE	0.005	4.8e-4
22-APR-2002	P0402.22	4-METHYL-2-PENTANONE	0.003	2.8e-4
22-APR-2002	P0402.22	ACETONE	0.22	0.022
22-APR-2002	P0402.22	BROMOMETHANE	0.002	2.0e-4
22-APR-2002	P0402.22	CARBON DISULFIDE	3.4e-4	3.4e-5
22-APR-2002	P0402.22	CHLOROFORM	0.002	1.9e-4
22-APR-2002	P0402.22	CHLOROMETHANE	0.003	2.7e-4
22-APR-2002	P0402.22	METHYLENE CHLORIDE	0.01	0.001
29-APR-2002	P0402.29	2-BUTANONE	0.037	0.004
29-APR-2002	P0402.29	4-METHYL-2-PENTANONE	0.005	5.1e-4
29-APR-2002	P0402.29	ACETONE	1.7	0.17
29-APR-2002	P0402.29	CHLOROFORM	0.002	1.7e-4
29-APR-2002	P0402.29	CHLOROMETHANE	0.002	2.0e-4
29-APR-2002	P0402.29	METHYLENE CHLORIDE	0.004	4.4e-4
07-MAY-2002	P0502.07	2-BUTANONE	0.023	0.002
07-MAY-2002	P0502.07	4-METHYL-2-PENTANONE	0.004	3.8e-4
07-MAY-2002	P0502.07	ACETONE	1.2	0.12
07-MAY-2002	P0502.07	CHLOROFORM	0.002	1.9e-4
07-MAY-2002	P0502.07	CHLOROMETHANE	0.001	1.3e-4
07-MAY-2002	P0502.07	METHYLENE CHLORIDE	0.002	2.5e-4
13-MAY-2002	P0502.13	1,1,1-TRICHLOROETHANE	0.068	0.007
13-MAY-2002	P0502.13	2-BUTANONE	0.019	0.002

RADIOACTIVE LIQUID WASTE  
TREATMENT FACILITY  
VOC results by sample for TA50 Plant Feed  
01-JAN-2002 - 31-DEC-2002

Sample Date	Sample Number	Species	Concentration (mg/l)	Uncertainty (mg/l)
13-MAY-2002	P0502.13	4-METHYL-2-PENTANONE	0.006	6.1e-4
13-MAY-2002	P0502.13	ACETONE	0.76	0.076
13-MAY-2002	P0502.13	CHLOROFORM	0.002	2.1e-4
13-MAY-2002	P0502.13	METHYLENE CHLORIDE	0.003	3.2e-4
20-MAY-2002	P0502.20	1,1,1-TRICHLOROETHANE	0.009	9.1e-4
20-MAY-2002	P0502.20	4-METHYL-2-PENTANONE	0.004	4.4e-4
20-MAY-2002	P0502.20	ACETONE	0.12	0.012
20-MAY-2002	P0502.20	CHLOROFORM	0.002	2.1e-4
20-MAY-2002	P0502.20	METHYLENE CHLORIDE	0.008	7.5e-4
04-JUN-2002	P0602.04	1,1,1-TRICHLOROETHANE	3.8e-4	3.8e-5
04-JUN-2002	P0602.04	1,2,4-TRIMETHYLBENZENE	6.2e-4	6.2e-5
04-JUN-2002	P0602.04	2-BUTANONE	0.003	3.4e-4
04-JUN-2002	P0602.04	4-METHYL-2-PENTANONE	0.003	3.3e-4
04-JUN-2002	P0602.04	ACETONE	0.22	0.022
04-JUN-2002	P0602.04	CHLOROFORM	0.002	1.6e-4
04-JUN-2002	P0602.04	CHLOROMETHANE	4.8e-4	4.8e-5
04-JUN-2002	P0602.04	METHYLENE CHLORIDE	0.025	0.002
18-JUN-2002	P0602.18	ACETONE	0.3	0.03
18-JUN-2002	P0602.18	CHLOROFORM	0.003	2.7e-4
18-JUN-2002	P0602.18	CHLOROMETHANE	0.003	3.4e-4
18-JUN-2002	P0602.18	METHYLENE CHLORIDE	0.031	0.003
25-JUN-2002	P0602.25	1,1,1-TRICHLOROETHANE	3.9e-4	3.9e-5
25-JUN-2002	P0602.25	1,2,4-TRIMETHYLBENZENE	3.7e-4	3.7e-5
25-JUN-2002	P0602.25	2-BUTANONE	0.004	3.7e-4
25-JUN-2002	P0602.25	4-METHYL-2-PENTANONE	0.002	2.5e-4
25-JUN-2002	P0602.25	ACETONE	0.17	0.017
25-JUN-2002	P0602.25	BROMODICHLOROMETHANE	3.0e-4	3.0e-5
25-JUN-2002	P0602.25	BROMOMETHANE	8.0e-4	8.0e-5
25-JUN-2002	P0602.25	CHLORODIBROMOMETHANE	3.5e-4	3.5e-5
25-JUN-2002	P0602.25	CHLOROFORM	0.002	2.1e-4
25-JUN-2002	P0602.25	CHLOROMETHANE	0.001	1.3e-4
25-JUN-2002	P0602.25	METHYLENE CHLORIDE	3.4e-4	3.4e-5
25-JUN-2002	P0602.25	TOLUENE	2.9e-4	2.9e-5
01-JUL-2002	P0702.01	2-BUTANONE	0.007	7.3e-4
01-JUL-2002	P0702.01	4-METHYL-2-PENTANONE	0.009	9.2e-4
01-JUL-2002	P0702.01	ACETONE	0.15	0.015
01-JUL-2002	P0702.01	BROMODICHLOROMETHANE	2.3e-4	2.3e-5
01-JUL-2002	P0702.01	BROMOFORM	4.3e-4	4.3e-5
01-JUL-2002	P0702.01	CHLORODIBROMOMETHANE	3.4e-4	3.4e-5
01-JUL-2002	P0702.01	CHLOROFORM	0.002	1.7e-4
01-JUL-2002	P0702.01	CHLOROMETHANE	5.7e-4	5.7e-5
01-JUL-2002	P0702.01	ETHYLBENZENE	4.0e-4	4.0e-5
01-JUL-2002	P0702.01	TOLUENE	3.6e-4	3.6e-5
08-JUL-2002	P0702.08	4-METHYL-2-PENTANONE	0.002	2.3e-4
08-JUL-2002	P0702.08	ACETONE	0.1	0.01
08-JUL-2002	P0702.08	CHLOROMETHANE	0.001	1.4e-4
17-JUL-2002	P0702.17	2-BUTANONE	0.005	5.3e-4
17-JUL-2002	P0702.17	4-METHYL-2-PENTANONE	0.003	2.7e-4
17-JUL-2002	P0702.17	ACETONE	0.24	0.024
17-JUL-2002	P0702.17	BROMOFORM	7.7e-4	7.7e-5



RADIOACTIVE LIQUID WASTE  
TREATMENT FACILITY  
VOC results by sample for TA50 Plant Feed  
01-JAN-2002 - 31-DEC-2002

Sample Date	Sample Number	Species	Concentration (mg/l)	Uncertainty (mg/l)
17-JUL-2002	P0702.17	CHLOROFORM	0.006	5.8e-4
17-JUL-2002	P0702.17	CHLOROMETHANE	6.9e-4	6.9e-5
17-JUL-2002	P0702.17	METHYLENE CHLORIDE	0.002	1.6e-4
17-JUL-2002	P0702.17	TOLUENE	2.7e-4	2.7e-5
22-JUL-2002	P0702.22	ACETONE	0.42	0.042
22-JUL-2002	P0702.22	METHYLENE CHLORIDE	0.043	0.004
30-JUL-2002	P0702.30	2-BUTANONE	0.065	0.007
30-JUL-2002	P0702.30	ACETONE	0.55	0.055
30-JUL-2002	P0702.30	CHLOROMETHANE	0.005	4.8e-4
30-JUL-2002	P0702.30	METHYLENE CHLORIDE	0.024	0.002
05-AUG-2002	P0802.05	ACETONE	0.85	0.085
05-AUG-2002	P0802.05	CHLOROMETHANE	0.02	0.002
05-AUG-2002	P0802.05	METHYLENE CHLORIDE	0.2	0.02
12-AUG-2002	P0802.12	ACETONE	2.2	0.22
12-AUG-2002	P0802.12	CHLOROMETHANE	0.018	0.002
12-AUG-2002	P0802.12	METHYLENE CHLORIDE	0.21	0.021
19-AUG-2002	P0802.19	2-BUTANONE	0.006	6.2e-4
19-AUG-2002	P0802.19	4-METHYL-2-PENTANONE	0.012	0.001
19-AUG-2002	P0802.19	ACETONE	0.62	0.062
19-AUG-2002	P0802.19	BROMODICHLOROMETHANE	3.0e-4	3.0e-5
19-AUG-2002	P0802.19	CHLOROFORM	0.002	1.7e-4
19-AUG-2002	P0802.19	CHLOROMETHANE	3.1e-4	3.1e-5
19-AUG-2002	P0802.19	METHYLENE CHLORIDE	7.5e-4	7.5e-5
19-AUG-2002	P0802.19	TOLUENE	2.6e-4	2.6e-5
26-AUG-2002	P0802.26	2-BUTANONE	0.006	5.7e-4
26-AUG-2002	P0802.26	4-METHYL-2-PENTANONE	0.005	4.7e-4
26-AUG-2002	P0802.26	ACETONE	1.3	0.13
26-AUG-2002	P0802.26	CHLOROFORM	0.001	1.0e-4
26-AUG-2002	P0802.26	METHYLENE CHLORIDE	8.1e-4	8.1e-5
03-SEP-2002	P0902.03	ACETONE	0.55	0.055
03-SEP-2002	P0902.03	BROMOFORM	0.012	0.001
03-SEP-2002	P0902.03	METHYLENE CHLORIDE	0.037	0.004
09-SEP-2002	P0902.09	ACETONE	0.78	0.078
09-SEP-2002	P0902.09	METHYLENE CHLORIDE	0.071	0.007
16-SEP-2002	P0902.16	ACETONE	0.63	0.063
16-SEP-2002	P0902.16	METHYLENE CHLORIDE	0.039	0.004
23-SEP-2002	P0902.23	ACETONE	2.1	0.21
23-SEP-2002	P0902.23	METHYLENE CHLORIDE	0.31	0.031
30-SEP-2002	P0902.30	ACETONE	1.3	0.13
30-SEP-2002	P0902.30	METHYLENE CHLORIDE	0.19	0.019
08-OCT-2002	P1002.08	ACETONE	0.46	0.046
08-OCT-2002	P1002.08	METHYLENE CHLORIDE	0.062	0.006
15-OCT-2002	P1002.15	2-BUTANONE	0.007	6.7e-4
15-OCT-2002	P1002.15	ACETONE	0.442	0.044
15-OCT-2002	P1002.15	CHLOROFORM	8.6e-4	8.6e-5
15-OCT-2002	P1002.15	TOLUENE	5.4e-4	5.4e-5
21-OCT-2002	P1002.21	ACETONE	1.1	0.11
21-OCT-2002	P1002.21	METHYLENE CHLORIDE	0.1	0.01
28-OCT-2002	P1002.28	ACETONE	0.19	0.019
28-OCT-2002	P1002.28	CHLOROMETHANE	0.007	7.0e-4

RADIOACTIVE LIQUID WASTE  
TREATMENT FACILITY

VOC results by species for TA50 Plant Feed  
01-JAN-2002 through 31-DEC-2002

Sample Date	Sample Number	Species	Concentration (mg/l)	Uncertainty (mg/l)
13-MAY-2002	P0502.13	1,1,1-TRICHLOROETHANE	0.068	0.007
20-MAY-2002	P0502.20	1,1,1-TRICHLOROETHANE	0.009	9.1e-4
04-JUN-2002	P0602.04	1,1,1-TRICHLOROETHANE	3.8e-4	3.8e-5
25-JUN-2002	P0602.25	1,1,1-TRICHLOROETHANE	3.9e-4	3.9e-5
25-NOV-2002	P1102.25	1,1,1-TRICHLOROETHANE	0.006	5.9e-4
25-NOV-2002	P1102.25	1,1-DICHLOROETHANE	0.002	1.8e-4
07-JAN-2002	P0102.07	1,2,4-TRIMETHYLBENZENE	5.2e-4	5.2e-5
22-JAN-2002	P0102.22	1,2,4-TRIMETHYLBENZENE	3.7e-4	3.7e-5
28-JAN-2002	P0102.28	1,2,4-TRIMETHYLBENZENE	9.9e-4	9.9e-5
12-FEB-2002	P0202.12	1,2,4-TRIMETHYLBENZENE	0.001	1.0e-4
02-APR-2002	P0402.02	1,2,4-TRIMETHYLBENZENE	0.001	1.4e-4
09-APR-2002	P0402.09	1,2,4-TRIMETHYLBENZENE	0.002	1.7e-4
15-APR-2002	P0402.15	1,2,4-TRIMETHYLBENZENE	7.5e-4	7.5e-5
22-APR-2002	P0402.22	1,2,4-TRIMETHYLBENZENE	9.4e-4	9.4e-5
04-JUN-2002	P0602.04	1,2,4-TRIMETHYLBENZENE	6.2e-4	6.2e-5
25-JUN-2002	P0602.25	1,2,4-TRIMETHYLBENZENE	3.7e-4	3.7e-5
07-JAN-2002	P0102.07	2-BUTANONE	0.006	6.3e-4
22-JAN-2002	P0102.22	2-BUTANONE	0.011	0.001
28-JAN-2002	P0102.28	2-BUTANONE	0.004	4.2e-4
12-FEB-2002	P0202.12	2-BUTANONE	0.004	3.5e-4
02-APR-2002	P0402.02	2-BUTANONE	0.005	5.3e-4
09-APR-2002	P0402.09	2-BUTANONE	0.027	0.003
15-APR-2002	P0402.15	2-BUTANONE	0.012	0.001
22-APR-2002	P0402.22	2-BUTANONE	0.005	4.8e-4
29-APR-2002	P0402.29	2-BUTANONE	0.037	0.004
07-MAY-2002	P0502.07	2-BUTANONE	0.023	0.002
13-MAY-2002	P0502.13	2-BUTANONE	0.019	0.002
04-JUN-2002	P0602.04	2-BUTANONE	0.003	3.4e-4
25-JUN-2002	P0602.25	2-BUTANONE	0.004	3.7e-4
01-JUL-2002	P0702.01	2-BUTANONE	0.007	7.3e-4
17-JUL-2002	P0702.17	2-BUTANONE	0.005	5.3e-4
30-JUL-2002	P0702.30	2-BUTANONE	0.065	0.007
19-AUG-2002	P0802.19	2-BUTANONE	0.006	6.2e-4
26-AUG-2002	P0802.26	2-BUTANONE	0.006	5.7e-4
15-OCT-2002	P1002.15	2-BUTANONE	0.007	6.7e-4
19-NOV-2002	P1102.19	2-BUTANONE	0.005	5.4e-4
22-JAN-2002	P0102.22	2-HEXANONE	0.008	7.6e-4
07-JAN-2002	P0102.07	4-METHYL-2-PENTANONE	0.003	3.0e-4
22-JAN-2002	P0102.22	4-METHYL-2-PENTANONE	0.002	1.7e-4
28-JAN-2002	P0102.28	4-METHYL-2-PENTANONE	0.003	2.6e-4
07-FEB-2002	P0202.07	4-METHYL-2-PENTANONE	0.004	4.3e-4
12-FEB-2002	P0202.12	4-METHYL-2-PENTANONE	0.002	2.3e-4
21-FEB-2002	P0202.21	4-METHYL-2-PENTANONE	0.005	4.8e-4
02-APR-2002	P0402.02	4-METHYL-2-PENTANONE	0.015	0.002
09-APR-2002	P0402.09	4-METHYL-2-PENTANONE	0.015	0.002
15-APR-2002	P0402.15	4-METHYL-2-PENTANONE	0.004	4.3e-4
22-APR-2002	P0402.22	4-METHYL-2-PENTANONE	0.003	2.8e-4
29-APR-2002	P0402.29	4-METHYL-2-PENTANONE	0.005	5.1e-4
07-MAY-2002	P0502.07	4-METHYL-2-PENTANONE	0.004	3.6e-4
13-MAY-2002	P0502.13	4-METHYL-2-PENTANONE	0.006	6.1e-4

RADIOACTIVE LIQUID WASTE  
TREATMENT FACILITY

VOC results by species for TA50 Plant Feed  
01-JAN-2002 through 31-DEC-2002

Sample Date	Sample Number	Species	Concentration (mg/l)	Uncertainty (mg/l)
20-MAY-2002	P0502.20	4-METHYL-2-PENTANONE	0.004	4.4e-4
04-JUN-2002	P0602.04	4-METHYL-2-PENTANONE	0.003	3.3e-4
25-JUN-2002	P0602.25	4-METHYL-2-PENTANONE	0.002	2.5e-4
01-JUL-2002	P0702.01	4-METHYL-2-PENTANONE	0.009	9.2e-4
08-JUL-2002	P0702.08	4-METHYL-2-PENTANONE	0.002	2.3e-4
17-JUL-2002	P0702.17	4-METHYL-2-PENTANONE	0.003	2.7e-4
19-AUG-2002	P0802.19	4-METHYL-2-PENTANONE	0.012	0.001
26-AUG-2002	P0802.26	4-METHYL-2-PENTANONE	0.005	4.7e-4
19-NOV-2002	P1102.19	4-METHYL-2-PENTANONE	0.003	2.7e-4
25-NOV-2002	P1102.25	4-METHYL-2-PENTANONE	0.003	2.7e-4
09-DEC-2002	P1202.09	4-METHYL-2-PENTANONE	0.005	5.2e-4
07-JAN-2002	P0102.07	ACETONE	0.25	0.025
14-JAN-2002	P0102.14	ACETONE	3.3	0.33
22-JAN-2002	P0102.22	ACETONE	0.51	0.051
28-JAN-2002	P0102.28	ACETONE	1.2	0.12
07-FEB-2002	P0202.07	ACETONE	1.1	0.11
12-FEB-2002	P0202.12	ACETONE	0.83	0.083
21-FEB-2002	P0202.21	ACETONE	1.8	0.18
26-FEB-2002	P0202.26	ACETONE	0.84	0.084
04-MAR-2002	P0302.04	ACETONE	0.87	0.087
25-MAR-2002	P0302.25	ACETONE	0.26	0.026
02-APR-2002	P0402.02	ACETONE	0.27	0.027
09-APR-2002	P0402.09	ACETONE	1.2	0.12
15-APR-2002	P0402.15	ACETONE	0.36	0.036
22-APR-2002	P0402.22	ACETONE	0.22	0.022
29-APR-2002	P0402.29	ACETONE	1.7	0.17
07-MAY-2002	P0502.07	ACETONE	1.2	0.12
13-MAY-2002	P0502.13	ACETONE	0.76	0.076
20-MAY-2002	P0502.20	ACETONE	0.12	0.012
04-JUN-2002	P0602.04	ACETONE	0.22	0.022
18-JUN-2002	P0602.18	ACETONE	0.3	0.03
25-JUN-2002	P0602.25	ACETONE	0.17	0.017
01-JUL-2002	P0702.01	ACETONE	0.15	0.015
08-JUL-2002	P0702.08	ACETONE	0.1	0.01
17-JUL-2002	P0702.17	ACETONE	0.24	0.024
22-JUL-2002	P0702.22	ACETONE	0.42	0.042
30-JUL-2002	P0702.30	ACETONE	0.55	0.055
05-AUG-2002	P0802.05	ACETONE	0.85	0.085
12-AUG-2002	P0802.12	ACETONE	2.2	0.22
19-AUG-2002	P0802.19	ACETONE	0.62	0.062
26-AUG-2002	P0802.26	ACETONE	1.3	0.13
03-SEP-2002	P0902.03	ACETONE	0.55	0.055
09-SEP-2002	P0902.09	ACETONE	0.78	0.078
16-SEP-2002	P0902.16	ACETONE	0.63	0.063
23-SEP-2002	P0902.23	ACETONE	2.1	0.21
30-SEP-2002	P0902.30	ACETONE	1.3	0.13
08-OCT-2002	P1002.08	ACETONE	0.46	0.046
15-OCT-2002	P1002.15	ACETONE	0.442	0.044
21-OCT-2002	P1002.21	ACETONE	1.1	0.11
28-OCT-2002	P1002.28	ACETONE	0.19	0.019

RADIOACTIVE LIQUID WASTE  
TREATMENT FACILITY

VOC results by species for TA50 Plant Feed  
01-JAN-2002 through 31-DEC-2002

Sample Date	Sample Number	Species	Concentration (mg/l)	Uncertainty (mg/l)
05-NOV-2002	P1102.05	ACETONE	0.77	0.077
12-NOV-2002	P1102.12	ACETONE	0.63	0.063
19-NOV-2002	P1102.19	ACETONE	0.19	0.019
25-NOV-2002	P1102.25	ACETONE	0.17	0.017
02-DEC-2002	P1202.02	ACETONE	0.25	0.025
09-DEC-2002	P1202.09	ACETONE	0.28	0.028
16-DEC-2002	P1202.16	ACETONE	0.23	0.023
02-APR-2002	P0402.02	BROMODICHLOROMETHANE	2.3e-4	2.3e-5
25-JUN-2002	P0602.25	BROMODICHLOROMETHANE	3.0e-4	3.0e-5
01-JUL-2002	P0702.01	BROMODICHLOROMETHANE	2.3e-4	2.3e-5
19-AUG-2002	P0802.19	BROMODICHLOROMETHANE	3.0e-4	3.0e-5
01-JUL-2002	P0702.01	BROMOFORM	4.3e-4	4.3e-5
17-JUL-2002	P0702.17	BROMOFORM	7.7e-4	7.7e-5
03-SEP-2002	P0902.03	BROMOFORM	0.012	0.001
07-JAN-2002	P0102.07	BROMOMETHANE	0.002	2.0e-4
22-JAN-2002	P0102.22	BROMOMETHANE	7.3e-4	7.3e-5
15-APR-2002	P0402.15	BROMOMETHANE	0.001	1.3e-4
22-APR-2002	P0402.22	BROMOMETHANE	0.002	2.0e-4
25-JUN-2002	P0602.25	BROMOMETHANE	8.0e-4	8.0e-5
15-APR-2002	P0402.15	CARBON DISULFIDE	5.3e-4	5.3e-5
22-APR-2002	P0402.22	CARBON DISULFIDE	3.4e-4	3.4e-5
25-JUN-2002	P0602.25	CHLORODIBROMOMETHANE	3.5e-4	3.5e-5
01-JUL-2002	P0702.01	CHLORODIBROMOMETHANE	3.4e-4	3.4e-5
03-JAN-2002	P0102.03	CHLOROFORM	4.4e-4	4.4e-5
07-JAN-2002	P0102.07	CHLOROFORM	4.9e-4	4.9e-5
14-JAN-2002	P0102.14	CHLOROFORM	0.086	0.009
22-JAN-2002	P0102.22	CHLOROFORM	0.001	1.2e-4
28-JAN-2002	P0102.28	CHLOROFORM	0.001	1.2e-4
07-FEB-2002	P0202.07	CHLOROFORM	0.003	3.1e-4
12-FEB-2002	P0202.12	CHLOROFORM	0.005	5.1e-4
21-FEB-2002	P0202.21	CHLOROFORM	0.009	8.6e-4
26-FEB-2002	P0202.26	CHLOROFORM	0.003	3.0e-4
04-MAR-2002	P0302.04	CHLOROFORM	0.002	1.9e-4
25-MAR-2002	P0302.25	CHLOROFORM	0.003	2.6e-4
02-APR-2002	P0402.02	CHLOROFORM	0.002	1.7e-4
09-APR-2002	P0402.09	CHLOROFORM	0.002	2.3e-4
15-APR-2002	P0402.15	CHLOROFORM	0.001	1.4e-4
22-APR-2002	P0402.22	CHLOROFORM	0.002	1.9e-4
29-APR-2002	P0402.29	CHLOROFORM	0.002	1.7e-4
07-MAY-2002	P0502.07	CHLOROFORM	0.002	1.9e-4
13-MAY-2002	P0502.13	CHLOROFORM	0.002	2.1e-4
20-MAY-2002	P0502.20	CHLOROFORM	0.002	2.1e-4
04-JUN-2002	P0602.04	CHLOROFORM	0.002	1.6e-4
18-JUN-2002	P0602.18	CHLOROFORM	0.003	2.7e-4
25-JUN-2002	P0602.25	CHLOROFORM	0.002	2.1e-4
01-JUL-2002	P0702.01	CHLOROFORM	0.002	1.7e-4
17-JUL-2002	P0702.17	CHLOROFORM	0.006	5.8e-4
19-AUG-2002	P0802.19	CHLOROFORM	0.002	1.7e-4
26-AUG-2002	P0802.26	CHLOROFORM	0.001	1.0e-4
15-OCT-2002	P1002.15	CHLOROFORM	8.8e-4	8.8e-5

RADIOACTIVE LIQUID WASTE  
TREATMENT FACILITY

VOC results by species for TA50 Plant Feed  
01-JAN-2002 through 31-DEC-2002

Sample Date	Sample Number	Species	Concentration (mg/l)	Uncertainty (mg/l)
19-NOV-2002	P1102.19	CHLOROFORM	0.01	9.8e-4
25-NOV-2002	P1102.25	CHLOROFORM	0.003	3.3e-4
07-JAN-2002	P0102.07	CHLOROMETHANE	7.8e-4	7.8e-5
12-FEB-2002	P0202.12	CHLOROMETHANE	2.3e-4	2.3e-5
02-APR-2002	P0402.02	CHLOROMETHANE	2.5e-4	2.5e-5
15-APR-2002	P0402.15	CHLOROMETHANE	0.002	2.2e-4
22-APR-2002	P0402.22	CHLOROMETHANE	0.003	2.7e-4
29-APR-2002	P0402.29	CHLOROMETHANE	0.002	2.0e-4
07-MAY-2002	P0502.07	CHLOROMETHANE	0.001	1.3e-4
04-JUN-2002	P0602.04	CHLOROMETHANE	4.8e-4	4.8e-5
18-JUN-2002	P0602.18	CHLOROMETHANE	0.003	3.4e-4
25-JUN-2002	P0602.25	CHLOROMETHANE	0.001	1.3e-4
01-JUL-2002	P0702.01	CHLOROMETHANE	5.7e-4	5.7e-5
08-JUL-2002	P0702.08	CHLOROMETHANE	0.001	1.4e-4
17-JUL-2002	P0702.17	CHLOROMETHANE	6.9e-4	6.9e-5
30-JUL-2002	P0702.30	CHLOROMETHANE	0.005	4.8e-4
05-AUG-2002	P0802.05	CHLOROMETHANE	0.02	0.002
12-AUG-2002	P0802.12	CHLOROMETHANE	0.018	0.002
19-AUG-2002	P0802.19	CHLOROMETHANE	3.1e-4	3.1e-5
28-OCT-2002	P1002.28	CHLOROMETHANE	0.007	7.0e-4
01-JUL-2002	P0702.01	ETHYLBENZENE	4.0e-4	4.0e-5
07-JAN-2002	P0102.07	IODOMETHANE	0.005	5.4e-4
22-JAN-2002	P0102.22	IODOMETHANE	0.002	1.5e-4
15-APR-2002	P0402.15	IODOMETHANE	0.004	4.2e-4
03-JAN-2002	P0102.03	METHYLENE CHLORIDE	0.001	1.4e-4
14-JAN-2002	P0102.14	METHYLENE CHLORIDE	0.27	0.027
07-FEB-2002	P0202.07	METHYLENE CHLORIDE	0.003	2.9e-4
12-FEB-2002	P0202.12	METHYLENE CHLORIDE	2.5e-4	2.5e-5
21-FEB-2002	P0202.21	METHYLENE CHLORIDE	0.013	0.001
26-FEB-2002	P0202.26	METHYLENE CHLORIDE	0.003	3.0e-4
04-MAR-2002	P0302.04	METHYLENE CHLORIDE	0.002	1.5e-4
25-MAR-2002	P0302.25	METHYLENE CHLORIDE	0.005	5.2e-4
02-APR-2002	P0402.02	METHYLENE CHLORIDE	0.003	3.0e-4
09-APR-2002	P0402.09	METHYLENE CHLORIDE	4.8e-4	4.8e-5
15-APR-2002	P0402.15	METHYLENE CHLORIDE	4.8e-4	4.8e-5
22-APR-2002	P0402.22	METHYLENE CHLORIDE	0.01	0.001
29-APR-2002	P0402.29	METHYLENE CHLORIDE	0.004	4.4e-4
07-MAY-2002	P0502.07	METHYLENE CHLORIDE	0.002	2.5e-4
13-MAY-2002	P0502.13	METHYLENE CHLORIDE	0.003	3.2e-4
20-MAY-2002	P0502.20	METHYLENE CHLORIDE	0.008	7.5e-4
04-JUN-2002	P0602.04	METHYLENE CHLORIDE	0.025	0.002
18-JUN-2002	P0602.18	METHYLENE CHLORIDE	0.031	0.003
25-JUN-2002	P0602.25	METHYLENE CHLORIDE	3.4e-4	3.4e-5
17-JUL-2002	P0702.17	METHYLENE CHLORIDE	0.002	1.6e-4
22-JUL-2002	P0702.22	METHYLENE CHLORIDE	0.043	0.004
30-JUL-2002	P0702.30	METHYLENE CHLORIDE	0.024	0.002
05-AUG-2002	P0802.05	METHYLENE CHLORIDE	0.2	0.02
12-AUG-2002	P0802.12	METHYLENE CHLORIDE	0.21	0.021
19-AUG-2002	P0802.19	METHYLENE CHLORIDE	7.5e-4	7.5e-5
26-AUG-2002	P0802.26	METHYLENE CHLORIDE	8.1e-4	8.1e-5

RADIOACTIVE LIQUID WASTE  
TREATMENT FACILITY  
SVOC results by sample for TA50 Plant Feed  
01-JAN-2002 - 31-DEC-2002

Sample Date	Sample Number	Species	Concentration (mg/l)	Uncertainty (mg/l)
03-JAN-2002	P0102.03	BIS(2-ETHYLHEXYL)PHTHALATE	0.041	0.004
03-JAN-2002	P0102.03	DIETHYL PHTHALATE	0.002	2.2e-4
07-JAN-2002	P0102.07	BENZOIC ACID	0.025	0.002
07-JAN-2002	P0102.07	BENZYL ALCOHOL	0.003	3.2e-4
07-JAN-2002	P0102.07	DI-N-OCTYL PHTHALATE	0.018	0.002
14-JAN-2002	P0102.14	BENZOIC ACID	0.027	0.003
14-JAN-2002	P0102.14	BIS(2-ETHYLHEXYL)PHTHALATE	0.014	0.001
22-JAN-2002	P0102.22	BENZOIC ACID	0.065	0.007
22-JAN-2002	P0102.22	BIS(2-ETHYLHEXYL)PHTHALATE	0.044	0.004
22-JAN-2002	P0102.22	PHENOL	0.002	2.1e-4
28-JAN-2002	P0102.28	BENZOIC ACID	0.057	0.006
28-JAN-2002	P0102.28	BIS(2-ETHYLHEXYL)PHTHALATE	0.005	5.3e-4
07-FEB-2002	P0202.07	BENZOIC ACID	0.057	0.006
07-FEB-2002	P0202.07	BIS(2-ETHYLHEXYL)PHTHALATE	0.012	0.001
07-FEB-2002	P0202.07	BUTYLBENZYLPHthalATE	0.01	9.5e-4
12-FEB-2002	P0202.12	BENZOIC ACID	0.027	0.003
21-FEB-2002	P0202.21	BENZOIC ACID	0.017	0.002
21-FEB-2002	P0202.21	BIS(2-ETHYLHEXYL)PHTHALATE	0.008	8.2e-4
21-FEB-2002	P0202.21	PYRIDINE	0.01	0.001
26-FEB-2002	P0202.26	BENZOIC ACID	0.031	0.003
26-FEB-2002	P0202.26	BENZYL ALCOHOL	0.004	3.6e-4
26-FEB-2002	P0202.26	PYRIDINE	0.005	4.7e-4
04-MAR-2002	P0302.04	BENZOIC ACID	0.063	0.006
04-MAR-2002	P0302.04	BIS(2-ETHYLHEXYL)PHTHALATE	0.007	6.8e-4
02-APR-2002	P0402.02	BENZOIC ACID	0.031	0.003
22-APR-2002	P0402.22	PHENOL	0.017	0.002
29-APR-2002	P0402.29	BENZOIC ACID	0.14	0.014
29-APR-2002	P0402.29	PYRIDINE	0.042	0.004
07-MAY-2002	P0502.07	BENZOIC ACID	0.081	0.009
07-MAY-2002	P0502.07	BIS(2-ETHYLHEXYL)PHTHALATE	0.006	5.6e-4
07-MAY-2002	P0502.07	PYRIDINE	0.015	0.002
13-MAY-2002	P0502.13	BENZOIC ACID	0.043	0.004
13-MAY-2002	P0502.13	PYRIDINE	0.014	0.001
20-MAY-2002	P0502.20	BENZOIC ACID	0.029	0.003
20-MAY-2002	P0502.20	BIS(2-ETHYLHEXYL)PHTHALATE	0.006	5.6e-4
04-JUN-2002	P0602.04	BIS(2-ETHYLHEXYL)PHTHALATE	0.007	6.9e-4
04-JUN-2002	P0602.04	PYRIDINE	0.006	5.9e-4
18-JUN-2002	P0602.18	BENZOIC ACID	0.021	0.002
18-JUN-2002	P0602.18	BIS(2-ETHYLHEXYL)PHTHALATE	0.005	4.5e-4
25-JUN-2002	P0602.25	BENZOIC ACID	0.004	3.7e-4
25-JUN-2002	P0602.25	BIS(2-ETHYLHEXYL)PHTHALATE	0.01	9.6e-4
01-JUL-2002	P0702.01	BENZOIC ACID	0.029	0.003
01-JUL-2002	P0702.01	BIS(2-ETHYLHEXYL)PHTHALATE	0.005	5.1e-4
08-JUL-2002	P0702.08	BIS(2-ETHYLHEXYL)PHTHALATE	0.009	9.0e-4
17-JUL-2002	P0702.17	BIS(2-ETHYLHEXYL)PHTHALATE	0.007	7.0e-4
17-JUL-2002	P0702.17	BUTYLBENZYLPHthalATE	0.005	4.9e-4
17-JUL-2002	P0702.17	PYRIDINE	0.02	0.002
22-JUL-2002	P0702.22	BIS(2-ETHYLHEXYL)PHTHALATE	0.017	0.002
22-JUL-2002	P0702.22	PYRIDINE	0.007	7.4e-4
30-JUL-2002	P0702.30	BENZOIC ACID	0.093	0.009

RADIOACTIVE LIQUID WASTE  
TREATMENT FACILITY

SVOC results by sample for TA50 Plant Feed  
01-JAN-2002 - 31-DEC-2002

Sample Date	Sample Number	Species	Concentration (mg/l)	Uncertainty (mg/l)
30-JUL-2002	P0702.30	BIS(2-ETHYLHEXYL)PHTHALATE	0.011	0.001
30-JUL-2002	P0702.30	PYRIDINE	0.014	0.001
05-AUG-2002	P0802.05	BENZOIC ACID	0.027	0.003
05-AUG-2002	P0802.05	BIS(2-ETHYLHEXYL)PHTHALATE	0.006	5.9e-4
12-AUG-2002	P0802.12	BIS(2-ETHYLHEXYL)PHTHALATE	0.005	5.4e-4
19-AUG-2002	P0802.19	BENZOIC ACID	0.016	0.002
19-AUG-2002	P0802.19	BIS(2-ETHYLHEXYL)PHTHALATE	0.017	0.002
19-AUG-2002	P0802.19	BUTYLBENZYLPHTHALATE	0.005	4.5e-4
26-AUG-2002	P0802.26	BENZOIC ACID	0.047	0.005
26-AUG-2002	P0802.26	BIS(2-ETHYLHEXYL)PHTHALATE	0.01	9.5e-4
03-SEP-2002	P0902.03	AZOBENZENE	0.004	4.1e-4
03-SEP-2002	P0902.03	BENZOIC ACID	0.042	0.004
03-SEP-2002	P0902.03	NITROBENZENE	0.002	2.1e-4
03-SEP-2002	P0902.03	PYRIDINE	0.038	0.004
09-SEP-2002	P0902.09	BENZOIC ACID	0.003	3.4e-4
09-SEP-2002	P0902.09	BIS(2-ETHYLHEXYL)PHTHALATE	0.008	8.4e-4
09-SEP-2002	P0902.09	PYRIDINE	0.008	7.7e-4
16-SEP-2002	P0902.16	AZOBENZENE	0.002	2.5e-4
16-SEP-2002	P0902.16	BENZOIC ACID	0.022	0.002
16-SEP-2002	P0902.16	BIS(2-ETHYLHEXYL)PHTHALATE	0.095	0.01
23-SEP-2002	P0902.23	BENZOIC ACID	0.027	0.003
23-SEP-2002	P0902.23	BENZYL ALCOHOL	0.002	2.4e-4
23-SEP-2002	P0902.23	BIS(2-ETHYLHEXYL)PHTHALATE	0.011	0.001
30-SEP-2002	P0902.30	BENZOIC ACID	0.083	0.008
30-SEP-2002	P0902.30	BIS(2-ETHYLHEXYL)PHTHALATE	0.007	7.2e-4
08-OCT-2002	P1002.08	BENZOIC ACID	0.033	0.003
08-OCT-2002	P1002.08	BENZYL ALCOHOL	0.002	2.4e-4
08-OCT-2002	P1002.08	BIS(2-ETHYLHEXYL)PHTHALATE	0.013	0.001
08-OCT-2002	P1002.08	BUTYLBENZYLPHTHALATE	0.003	3.4e-4
21-OCT-2002	P1002.21	BENZOIC ACID	0.027	0.003
21-OCT-2002	P1002.21	BIS(2-ETHYLHEXYL)PHTHALATE	0.008	8.3e-4
28-OCT-2002	P1002.28	BENZOIC ACID	0.036	0.004
28-OCT-2002	P1002.28	BIS(2-ETHYLHEXYL)PHTHALATE	0.011	0.001
28-OCT-2002	P1002.28	BUTYLBENZYLPHTHALATE	0.007	7.3e-4
05-NOV-2002	P1102.05	BENZOIC ACID	0.068	0.007
05-NOV-2002	P1102.05	BIS(2-ETHYLHEXYL)PHTHALATE	0.009	8.9e-4
12-NOV-2002	P1102.12	BIS(2-ETHYLHEXYL)PHTHALATE	0.008	7.6e-4
19-NOV-2002	P1102.19	BENZOIC ACID	0.036	0.004
19-NOV-2002	P1102.19	BENZYL ALCOHOL	0.014	0.001
25-NOV-2002	P1102.25	BENZOIC ACID	0.07	0.007
25-NOV-2002	P1102.25	BENZYL ALCOHOL	0.015	0.002
25-NOV-2002	P1102.25	BIS(2-ETHYLHEXYL)PHTHALATE	0.013	0.001
02-DEC-2002	P1202.02	BENZOIC ACID	0.023	0.002
02-DEC-2002	P1202.02	BIS(2-ETHYLHEXYL)PHTHALATE	0.004	4.2e-4
02-DEC-2002	P1202.02	PYRIDINE	0.003	3.1e-4
09-DEC-2002	P1202.09	BENZO(A)PYRENE	0.003	2.8e-4
09-DEC-2002	P1202.09	BENZO(B)FLUORANTHENE	0.003	2.8e-4
09-DEC-2002	P1202.09	BENZOIC ACID	0.06	0.006
09-DEC-2002	P1202.09	BENZYL ALCOHOL	0.003	3.0e-4
09-DEC-2002	P1202.09	BIS(2-ETHYLHEXYL)PHTHALATE	0.01	9.8e-4

RADIOACTIVE LIQUID WASTE  
TREATMENT FACILITY

SVOC results by sample for TA50 Plant Feed  
01-JAN-2002 - 31-DEC-2002

Sample Date	Sample Number	Species	Concentration (mg/l)	Uncertainty (mg/l)
09-DEC-2002	P1202.09	BUTYLBENZYLPHTHALATE	0.003	3.4e-4
09-DEC-2002	P1202.09	PYRIDINE	0.004	4.4e-4
16-DEC-2002	P1202.16	BENZOIC ACID	0.003	2.7e-4
16-DEC-2002	P1202.16	BIS(2-ETHYLHEXYL)PHTHALATE	0.051	0.005
16-DEC-2002	P1202.16	BUTYLBENZYLPHTHALATE	0.004	4.1e-4
16-DEC-2002	P1202.16	DI-N-OCTYL PHTHALATE	0.003	2.7e-4

Issued 1 Apr 2003 7:17:19 a.m. Page 3 of 3.



RADIOACTIVE LIQUID WASTE  
TREATMENT FACILITY  
SVOC results by species for TA50 Plant Feed  
01-JAN-2002 through 31-DEC-2002

Sample Date	Sample Number	Species	Concentration (mg/l)	Uncertainty (mg/l)
03-SEP-2002	P0902.03	AZOBENZENE	0.004	4.1e-4
16-SEP-2002	P0902.16	AZOBENZENE	0.002	2.5e-4
09-DEC-2002	P1202.09	BENZO(A)PYRENE	0.003	2.8e-4
09-DEC-2002	P1202.09	BENZO(B)FLUORANTHENE	0.003	2.8e-4
07-JAN-2002	P0102.07	BENZOIC ACID	0.025	0.002
14-JAN-2002	P0102.14	BENZOIC ACID	0.027	0.003
22-JAN-2002	P0102.22	BENZOIC ACID	0.065	0.007
28-JAN-2002	P0102.28	BENZOIC ACID	0.057	0.006
07-FEB-2002	P0202.07	BENZOIC ACID	0.057	0.006
12-FEB-2002	P0202.12	BENZOIC ACID	0.027	0.003
21-FEB-2002	P0202.21	BENZOIC ACID	0.017	0.002
26-FEB-2002	P0202.26	BENZOIC ACID	0.031	0.003
04-MAR-2002	P0302.04	BENZOIC ACID	0.063	0.006
02-APR-2002	P0402.02	BENZOIC ACID	0.031	0.003
29-APR-2002	P0402.29	BENZOIC ACID	0.14	0.014
07-MAY-2002	P0502.07	BENZOIC ACID	0.091	0.009
13-MAY-2002	P0502.13	BENZOIC ACID	0.043	0.004
20-MAY-2002	P0502.20	BENZOIC ACID	0.029	0.003
18-JUN-2002	P0602.18	BENZOIC ACID	0.021	0.002
25-JUN-2002	P0602.25	BENZOIC ACID	0.004	3.7e-4
01-JUL-2002	P0702.01	BENZOIC ACID	0.029	0.003
30-JUL-2002	P0702.30	BENZOIC ACID	0.093	0.009
05-AUG-2002	P0802.05	BENZOIC ACID	0.027	0.003
19-AUG-2002	P0802.19	BENZOIC ACID	0.016	0.002
26-AUG-2002	P0802.26	BENZOIC ACID	0.047	0.005
03-SEP-2002	P0902.03	BENZOIC ACID	0.042	0.004
09-SEP-2002	P0902.09	BENZOIC ACID	0.003	3.4e-4
16-SEP-2002	P0902.16	BENZOIC ACID	0.022	0.002
23-SEP-2002	P0902.23	BENZOIC ACID	0.027	0.003
30-SEP-2002	P0902.30	BENZOIC ACID	0.083	0.008
08-OCT-2002	P1002.08	BENZOIC ACID	0.033	0.003
21-OCT-2002	P1002.21	BENZOIC ACID	0.027	0.003
28-OCT-2002	P1002.28	BENZOIC ACID	0.036	0.004
05-NOV-2002	P1102.05	BENZOIC ACID	0.068	0.007
19-NOV-2002	P1102.19	BENZOIC ACID	0.036	0.004
25-NOV-2002	P1102.25	BENZOIC ACID	0.07	0.007
02-DEC-2002	P1202.02	BENZOIC ACID	0.023	0.002
09-DEC-2002	P1202.09	BENZOIC ACID	0.06	0.006
16-DEC-2002	P1202.16	BENZOIC ACID	0.003	2.7e-4
07-JAN-2002	P0102.07	BENZYL ALCOHOL	0.003	3.2e-4
26-FEB-2002	P0202.26	BENZYL ALCOHOL	0.004	3.6e-4
23-SEP-2002	P0902.23	BENZYL ALCOHOL	0.002	2.4e-4
08-OCT-2002	P1002.08	BENZYL ALCOHOL	0.002	2.4e-4
19-NOV-2002	P1102.19	BENZYL ALCOHOL	0.014	0.001
25-NOV-2002	P1102.25	BENZYL ALCOHOL	0.015	0.002
09-DEC-2002	P1202.09	BENZYL ALCOHOL	0.003	3.0e-4
03-JAN-2002	P0102.03	BIS(2-ETHYLHEXYL)PHTHALATE	0.041	0.004
14-JAN-2002	P0102.14	BIS(2-ETHYLHEXYL)PHTHALATE	0.014	0.001
22-JAN-2002	P0102.22	BIS(2-ETHYLHEXYL)PHTHALATE	0.044	0.004
28-JAN-2002	P0102.28	BIS(2-ETHYLHEXYL)PHTHALATE	0.005	5.3e-4

RADIOACTIVE LIQUID WASTE  
TREATMENT FACILITY  
SVOC results by species for TA50 Plant Feed  
01-JAN-2002 through 31-DEC-2002

Sample Date	Sample Number	Species	Concentration (mg/l)	Uncertainty (mg/l)
07-FEB-2002	P0202.07	BIS(2-ETHYLHEXYL)PHTHALATE	0.012	0.001
21-FEB-2002	P0202.21	BIS(2-ETHYLHEXYL)PHTHALATE	0.008	8.2e-4
04-MAR-2002	P0302.04	BIS(2-ETHYLHEXYL)PHTHALATE	0.007	6.8e-4
07-MAY-2002	P0502.07	BIS(2-ETHYLHEXYL)PHTHALATE	0.006	5.6e-4
20-MAY-2002	P0502.20	BIS(2-ETHYLHEXYL)PHTHALATE	0.006	5.6e-4
04-JUN-2002	P0602.04	BIS(2-ETHYLHEXYL)PHTHALATE	0.007	6.9e-4
18-JUN-2002	P0602.18	BIS(2-ETHYLHEXYL)PHTHALATE	0.005	4.5e-4
25-JUN-2002	P0602.25	BIS(2-ETHYLHEXYL)PHTHALATE	0.01	9.6e-4
01-JUL-2002	P0702.01	BIS(2-ETHYLHEXYL)PHTHALATE	0.005	5.1e-4
08-JUL-2002	P0702.08	BIS(2-ETHYLHEXYL)PHTHALATE	0.009	9.0e-4
17-JUL-2002	P0702.17	BIS(2-ETHYLHEXYL)PHTHALATE	0.007	7.0e-4
22-JUL-2002	P0702.22	BIS(2-ETHYLHEXYL)PHTHALATE	0.017	0.002
30-JUL-2002	P0702.30	BIS(2-ETHYLHEXYL)PHTHALATE	0.011	0.001
05-AUG-2002	P0802.05	BIS(2-ETHYLHEXYL)PHTHALATE	0.006	5.9e-4
12-AUG-2002	P0802.12	BIS(2-ETHYLHEXYL)PHTHALATE	0.005	5.4e-4
19-AUG-2002	P0802.19	BIS(2-ETHYLHEXYL)PHTHALATE	0.017	0.002
26-AUG-2002	P0802.26	BIS(2-ETHYLHEXYL)PHTHALATE	0.01	9.5e-4
09-SEP-2002	P0902.09	BIS(2-ETHYLHEXYL)PHTHALATE	0.008	8.4e-4
16-SEP-2002	P0902.16	BIS(2-ETHYLHEXYL)PHTHALATE	0.095	0.01
23-SEP-2002	P0902.23	BIS(2-ETHYLHEXYL)PHTHALATE	0.011	0.001
30-SEP-2002	P0902.30	BIS(2-ETHYLHEXYL)PHTHALATE	0.007	7.2e-4
08-OCT-2002	P1002.08	BIS(2-ETHYLHEXYL)PHTHALATE	0.013	0.001
21-OCT-2002	P1002.21	BIS(2-ETHYLHEXYL)PHTHALATE	0.008	8.3e-4
28-OCT-2002	P1002.28	BIS(2-ETHYLHEXYL)PHTHALATE	0.011	0.001
05-NOV-2002	P1102.05	BIS(2-ETHYLHEXYL)PHTHALATE	0.009	8.9e-4
12-NOV-2002	P1102.12	BIS(2-ETHYLHEXYL)PHTHALATE	0.008	7.6e-4
25-NOV-2002	P1102.25	BIS(2-ETHYLHEXYL)PHTHALATE	0.013	0.001
02-DEC-2002	P1202.02	BIS(2-ETHYLHEXYL)PHTHALATE	0.004	4.2e-4
09-DEC-2002	P1202.09	BIS(2-ETHYLHEXYL)PHTHALATE	0.01	9.8e-4
16-DEC-2002	P1202.16	BIS(2-ETHYLHEXYL)PHTHALATE	0.051	0.005
07-FEB-2002	P0202.07	BUTYLBENZYLPHTHALATE	0.01	9.5e-4
17-JUL-2002	P0702.17	BUTYLBENZYLPHTHALATE	0.005	4.9e-4
19-AUG-2002	P0802.19	BUTYLBENZYLPHTHALATE	0.005	4.5e-4
08-OCT-2002	P1002.08	BUTYLBENZYLPHTHALATE	0.003	3.4e-4
28-OCT-2002	P1002.28	BUTYLBENZYLPHTHALATE	0.007	7.3e-4
09-DEC-2002	P1202.09	BUTYLBENZYLPHTHALATE	0.003	3.4e-4
16-DEC-2002	P1202.16	BUTYLBENZYLPHTHALATE	0.004	4.1e-4
07-JAN-2002	P0102.07	DI-N-OCTYL PHTHALATE	0.018	0.002
16-DEC-2002	P1202.16	DI-N-OCTYL PHTHALATE	0.003	2.7e-4
03-JAN-2002	P0102.03	DIETHYL PHTHALATE	0.002	2.2e-4
03-SEP-2002	P0902.03	NITROBENZENE	0.002	2.1e-4
22-JAN-2002	P0102.22	PHENOL	0.002	2.1e-4
22-APR-2002	P0402.22	PHENOL	0.017	0.002
21-FEB-2002	P0202.21	PYRDINE	0.01	0.001
26-FEB-2002	P0202.26	PYRDINE	0.005	4.7e-4
29-APR-2002	P0402.29	PYRDINE	0.042	0.004
07-MAY-2002	P0502.07	PYRDINE	0.015	0.002
13-MAY-2002	P0502.13	PYRDINE	0.014	0.001
04-JUN-2002	P0602.04	PYRDINE	0.006	5.9e-4
17-JUL-2002	P0702.17	PYRDINE	0.02	0.002

RADIOACTIVE LIQUID WASTE  
TREATMENT FACILITY

SVOC results by species for TA50 Plant Feed  
01-JAN-2002 through 31-DEC-2002

Sample Date	Sample Number	Species	Concentration (mg/l)	Uncertainty (mg/l)
22-JUL-2002	P0702.22	PYRIDINE	0.007	7.4e-4
30-JUL-2002	P0702.30	PYRIDINE	0.014	0.001
03-SEP-2002	P0902.03	PYRIDINE	0.038	0.004
09-SEP-2002	P0902.09	PYRIDINE	0.008	7.7e-4
02-DEC-2002	P1202.02	PYRIDINE	0.003	3.1e-4
09-DEC-2002	P1202.09	PYRIDINE	0.004	4.4e-4

Issued 1 Apr 2003 7:15:10 a.m. Page 3 of 3.

**Appendix I**

**TA-50 Plant Sludge VOC Results by Sample**

**Appendix J**

**TA-50 Plant Sludge VOC Results by Species**

**Appendix K**

**TA-50 Plant Sludge SVOC Results by Sample**

**Appendix L**

**TA-50 Plant Sludge SVOC Results by Species**

RADIOACTIVE LIQUID WASTE  
TREATMENT FACILITY

VOC results by sample for TA50 Plant Sludge  
01-JAN-2002 - 31-DEC-2002

Sample Date	Sample Number	Species	Concentration (mg/l)	Uncertainty (mg/l)
08-JAN-2002	50S0102.08	1,2,4-TRIMETHYLBENZENE	0.18	0.018
08-JAN-2002	50S0102.08	1,3,5-TRIMETHYLBENZENE	0.005	5.0e-4
08-JAN-2002	50S0102.08	4-METHYL-2-PENTANONE	0.009	9.1e-4
08-JAN-2002	50S0102.08	ACETONE	0.5	0.05
08-JAN-2002	50S0102.08	BROMOMETHANE	0.003	2.6e-4
08-JAN-2002	50S0102.08	CHLOROFORM	0.041	0.004
08-JAN-2002	50S0102.08	METHYLENE CHLORIDE	0.096	0.01
08-JAN-2002	50S0102.08	TOLUENE	0.068	0.007
21-FEB-2002	50S0202.21	1,2,4-TRIMETHYLBENZENE	0.16	0.016
21-FEB-2002	50S0202.21	2-BUTANONE	0.021	0.002
21-FEB-2002	50S0202.21	ACETONE	0.16	0.016
21-FEB-2002	50S0202.21	METHYLENE CHLORIDE	0.012	0.001
21-FEB-2002	50S0202.21	TOLUENE	0.007	6.5e-4
12-MAR-2002	50S0302.12	1,2,4-TRIMETHYLBENZENE	0.1	0.01
12-MAR-2002	50S0302.12	1,2-DICHLOROBENZENE	7.3e-4	7.3e-5
12-MAR-2002	50S0302.12	2-BUTANONE	0.012	0.001
12-MAR-2002	50S0302.12	4-METHYL-2-PENTANONE	0.004	3.9e-4
12-MAR-2002	50S0302.12	ACETONE	0.068	0.009
12-MAR-2002	50S0302.12	BROMOMETHANE	0.002	1.9e-4
12-MAR-2002	50S0302.12	METHYLENE CHLORIDE	0.004	3.9e-4
12-MAR-2002	50S0302.12	STYRENE	0.001	1.1e-4
12-MAR-2002	50S0302.12	TOLUENE	0.004	3.5e-4
12-MAR-2002	50S0302.12	TRICHLOROFLUOROMETHANE	0.002	1.6e-4
01-MAY-2002	50S0502.01	1,2,4-TRIMETHYLBENZENE	0.03	0.003
01-MAY-2002	50S0502.01	ACETONE	0.29	0.029
01-MAY-2002	50S0502.01	METHYLENE CHLORIDE	0.001	1.4e-4
01-MAY-2002	50S0502.01	TOLUENE	0.002	2.3e-4
24-JUN-2002	50S0602.24	1,2,4-TRIMETHYLBENZENE	0.11	0.011
24-JUN-2002	50S0602.24	2-BUTANONE	0.05	0.005
24-JUN-2002	50S0602.24	4-METHYL-2-PENTANONE	0.008	7.5e-4
24-JUN-2002	50S0602.24	ACETONE	0.72	0.072
24-JUN-2002	50S0602.24	CHLOROFORM	0.001	1.4e-4
24-JUN-2002	50S0602.24	METHYLENE CHLORIDE	0.049	0.005
24-JUN-2002	50S0602.24	TOLUENE	0.006	6.2e-4
22-JUL-2002	50S0702.22	1,2,4-TRIMETHYLBENZENE	0.043	0.004
22-JUL-2002	50S0702.22	2-BUTANONE	0.021	0.002
22-JUL-2002	50S0702.22	ACETONE	0.22	0.022
22-JUL-2002	50S0702.22	METHYLENE CHLORIDE	0.008	8.1e-4
22-JUL-2002	50S0702.22	TOLUENE	0.002	1.7e-4
27-AUG-2002	50S0802.27	1,2,4-TRIMETHYLBENZENE	0.035	0.004
27-AUG-2002	50S0802.27	1,3,5-TRIMETHYLBENZENE	0.004	3.8e-4
27-AUG-2002	50S0802.27	ACETONE	0.32	0.032
27-AUG-2002	50S0802.27	METHYLENE CHLORIDE	0.006	6.1e-4
27-AUG-2002	50S0802.27	TOLUENE	0.004	3.7e-4
01-OCT-2002	50S1002.01	1,2,4-TRIMETHYLBENZENE	0.034	0.003
01-OCT-2002	50S1002.01	ACETONE	0.48	0.048
01-OCT-2002	50S1002.01	METHYLENE CHLORIDE	0.023	0.002
01-OCT-2002	50S1002.01	TOLUENE	0.003	2.8e-4
19-NOV-2002	50S1102.19	1,2,4-TRIMETHYLBENZENE	0.004	4.4e-4
19-NOV-2002	50S1102.19	ACETONE	0.23	0.023

RADIOACTIVE LIQUID WASTE  
TREATMENT FACILITY

VOC results by sample for TA50 Plant Sludge  
01-JAN-2002 - 31-DEC-2002

Sample Date	Sample Number	Species	Concentration (mg/l)	Uncertainty (mg/l)
19-NOV-2002	50S1102.19	METHYLENE CHLORIDE	0.011	0.001
19-NOV-2002	50S1102.19	TOLUENE	6.5e-4	6.5e-5
17-DEC-2002	50S1202.17	ACETONE	2.35	0.235

Issued 1 Apr 2003 7:16:51 a.m. Page 2 of 2.

RADIOACTIVE LIQUID WASTE  
TREATMENT FACILITY

VOC results by species for TA50 Plant Sludge  
01-JAN-2002 through 31-DEC-2002

Sample Date	Sample Number	Species	Concentration (mg/l)	Uncertainty (mg/l)
08-JAN-2002	50S0102.08	1,2,4-TRIMETHYLBENZENE	0.18	0.018
21-FEB-2002	50S0202.21	1,2,4-TRIMETHYLBENZENE	0.16	0.016
12-MAR-2002	50S0302.12	1,2,4-TRIMETHYLBENZENE	0.1	0.01
01-MAY-2002	50S0502.01	1,2,4-TRIMETHYLBENZENE	0.03	0.003
24-JUN-2002	50S0602.24	1,2,4-TRIMETHYLBENZENE	0.11	0.011
22-JUL-2002	50S0702.22	1,2,4-TRIMETHYLBENZENE	0.043	0.004
27-AUG-2002	50S0802.27	1,2,4-TRIMETHYLBENZENE	0.035	0.004
01-OCT-2002	50S1002.01	1,2,4-TRIMETHYLBENZENE	0.034	0.003
19-NOV-2002	50S1102.19	1,2,4-TRIMETHYLBENZENE	0.004	4.4e-4
12-MAR-2002	50S0302.12	1,2-DICHLOROBENZENE	7.3e-4	7.3e-5
08-JAN-2002	50S0102.08	1,3,5-TRIMETHYLBENZENE	0.005	5.0e-4
27-AUG-2002	50S0802.27	1,3,5-TRIMETHYLBENZENE	0.004	3.8e-4
21-FEB-2002	50S0202.21	2-BUTANONE	0.021	0.002
12-MAR-2002	50S0302.12	2-BUTANONE	0.012	0.001
24-JUN-2002	50S0602.24	2-BUTANONE	0.05	0.005
22-JUL-2002	50S0702.22	2-BUTANONE	0.021	0.002
08-JAN-2002	50S0102.08	4-METHYL-2-PENTANONE	0.009	9.1e-4
12-MAR-2002	50S0302.12	4-METHYL-2-PENTANONE	0.004	3.9e-4
24-JUN-2002	50S0602.24	4-METHYL-2-PENTANONE	0.008	7.5e-4
08-JAN-2002	50S0102.08	ACETONE	0.5	0.05
21-FEB-2002	50S0202.21	ACETONE	0.16	0.016
12-MAR-2002	50S0302.12	ACETONE	0.088	0.009
01-MAY-2002	50S0502.01	ACETONE	0.29	0.029
24-JUN-2002	50S0602.24	ACETONE	0.72	0.072
22-JUL-2002	50S0702.22	ACETONE	0.22	0.022
27-AUG-2002	50S0802.27	ACETONE	0.32	0.032
01-OCT-2002	50S1002.01	ACETONE	0.48	0.048
19-NOV-2002	50S1102.19	ACETONE	0.23	0.023
17-DEC-2002	50S1202.17	ACETONE	2.35	0.235
08-JAN-2002	50S0102.08	BROMOMETHANE	0.003	2.6e-4
12-MAR-2002	50S0302.12	BROMOMETHANE	0.002	1.9e-4
08-JAN-2002	50S0102.08	CHLOROFORM	0.041	0.004
24-JUN-2002	50S0602.24	CHLOROFORM	0.001	1.4e-4
08-JAN-2002	50S0102.08	METHYLENE CHLORIDE	0.096	0.01
21-FEB-2002	50S0202.21	METHYLENE CHLORIDE	0.012	0.001
12-MAR-2002	50S0302.12	METHYLENE CHLORIDE	0.004	3.9e-4
01-MAY-2002	50S0502.01	METHYLENE CHLORIDE	0.001	1.4e-4
24-JUN-2002	50S0602.24	METHYLENE CHLORIDE	0.049	0.005
22-JUL-2002	50S0702.22	METHYLENE CHLORIDE	0.008	8.1e-4
27-AUG-2002	50S0802.27	METHYLENE CHLORIDE	0.006	6.1e-4
01-OCT-2002	50S1002.01	METHYLENE CHLORIDE	0.023	0.002
19-NOV-2002	50S1102.19	METHYLENE CHLORIDE	0.011	0.001
12-MAR-2002	50S0302.12	STYRENE	0.001	1.1e-4
08-JAN-2002	50S0102.08	TOLUENE	0.068	0.007
21-FEB-2002	50S0202.21	TOLUENE	0.007	6.5e-4
12-MAR-2002	50S0302.12	TOLUENE	0.004	3.5e-4
01-MAY-2002	50S0502.01	TOLUENE	0.002	2.3e-4
24-JUN-2002	50S0602.24	TOLUENE	0.006	6.2e-4
22-JUL-2002	50S0702.22	TOLUENE	0.002	1.7e-4
27-AUG-2002	50S0802.27	TOLUENE	0.004	3.7e-4

RADIOACTIVE LIQUID WASTE  
TREATMENT FACILITY

VOC results by species for TA50 Plant Sludge  
01-JAN-2002 through 31-DEC-2002

Sample Date	Sample Number	Species	Concentration (mg/l)	Uncertainty (mg/l)
01-OCT-2002	50S1002.01	TOLUENE	0.003	2.8e-4
19-NOV-2002	50S1102.19	TOLUENE	6.5e-4	6.5e-5
12-MAR-2002	50S0302.12	TRICHLOROFLUOROMETHANE	0.002	1.6e-4

Issued 1 Apr 2003 7:14:53 a.m. Page 2 of 2.



RADIOACTIVE LIQUID WASTE  
TREATMENT FACILITY

SVOC results by sample for TA50 Plant Sludge  
01-JAN-2002 - 31-DEC-2002

Sample Date	Sample Number	Species	Concentration (mg/l)	Uncertainty (mg/l)
08-JAN-2002	50S0102.08	BIS(2-ETHYLHEXYL)PHTHALATE	8.7	0.87
08-JAN-2002	50S0102.08	PHENOL	0.73	0.073
21-FEB-2002	50S0202.21	BIS(2-ETHYLHEXYL)PHTHALATE	7.2	0.72
12-MAR-2002	50S0302.12	BIS(2-ETHYLHEXYL)PHTHALATE	6.8	0.68
01-MAY-2002	50S0502.01	BIS(2-ETHYLHEXYL)PHTHALATE	2.5	0.25
24-JUN-2002	50S0602.24	BIS(2-ETHYLHEXYL)PHTHALATE	30.0	3.0
27-AUG-2002	50S0802.27	BIS(2-ETHYLHEXYL)PHTHALATE	7.8	0.78
01-OCT-2002	50S1002.01	BIS(2-ETHYLHEXYL)PHTHALATE	15.0	1.5
19-NOV-2002	50S1102.19	BIS(2-ETHYLHEXYL)PHTHALATE	3.5	0.35
19-NOV-2002	50S1102.19	DI-N-OCTYL PHTHALATE	0.21	0.021
17-DEC-2002	50S1202.17	BIS(2-ETHYLHEXYL)PHTHALATE	10.8	1.08

Issued 1 Apr 2003 7:17:19 a.m. Page 1 of 1.

RADIOACTIVE LIQUID WASTE  
TREATMENT FACILITY

SVOC results by species for TA50 Plant Sludge  
01-JAN-2002 through 31-DEC-2002

Sample Date	Sample Number	Species	Concentration (mg/l)	Uncertainty (mg/l)
08-JAN-2002	50S0102.08	BIS(2-ETHYLHEXYL)PHTHALATE	8.7	0.87
21-FEB-2002	50S0202.21	BIS(2-ETHYLHEXYL)PHTHALATE	7.2	0.72
12-MAR-2002	50S0302.12	BIS(2-ETHYLHEXYL)PHTHALATE	6.8	0.68
01-MAY-2002	50S0502.01	BIS(2-ETHYLHEXYL)PHTHALATE	2.5	0.25
24-JUN-2002	50S0602.24	BIS(2-ETHYLHEXYL)PHTHALATE	30.0	3.0
27-AUG-2002	50S0802.27	BIS(2-ETHYLHEXYL)PHTHALATE	7.8	0.78
01-OCT-2002	50S1002.01	BIS(2-ETHYLHEXYL)PHTHALATE	15.0	1.5
19-NOV-2002	50S1102.19	BIS(2-ETHYLHEXYL)PHTHALATE	3.5	0.35
17-DEC-2002	50S1202.17	BIS(2-ETHYLHEXYL)PHTHALATE	10.8	1.08
19-NOV-2002	50S1102.19	DI-N-OCTYL PHTHALATE	0.21	0.021
08-JAN-2002	50S0102.08	PHENOL	0.73	0.073

Issued 1 Apr 2003 7:15:11 a.m. Page 1 of 1.





JUN 27 2003

*Risk Reduction & Environmental Stewardship Division  
Water Quality & Hydrology Group (RRES-WQH)*  
PO Box 1663, MS K497

Los Alamos, New Mexico 87545  
(505) 665-1859/Fax: (505) 665-9344

Date: June 24, 2003  
Refer to: RRES-WQH: 03-148

Mr. Curt Frischkorn  
Pollution Prevention Section  
Ground Water Quality Bureau  
New Mexico Environment Department  
P.O. Box 26110  
Santa Fe, New Mexico 87502

**SUBJECT: TA-50 RADIOACTIVE LIQUID WASTE TREATMENT FACILITY, GROUND WATER DISCHARGE PLAN (DP-1132), MINOR MODIFICATION**

Dear Mr. Frischkorn:

In accordance with Section 3107 of the New Mexico Water Quality Control Commission Regulations, I am notifying you of a minor modification to Los Alamos National Laboratory's Ground Water Discharge Plan (DP-1132) for the TA-50 Radioactive Liquid Waste Treatment Facility (RLWTF). The TA-50 RLWTF intends to replace a section of the existing 6-inch outfall pipeline with the out-of-service 3-inch cross-country pipeline (See Enclosure 1). Historically, the cross-country pipeline was used to transport treated wastewater from TA-21, Building 257, to the TA-50 RLWTF. However, the Laboratory flushed and removed the cross-country pipeline from service on July 21, 2001. Replacement of the existing 6-inch outfall pipeline has been initiated to mitigate the problem of radiological contaminants that are leaching from the inner walls of the pipe.

In addition to pipeline replacement, this project also includes the installation of a new discharge pump from the effluent tanks (frac tanks) to the cross-country pipeline. The cross-country pipeline will be connected to the existing 6-inch pipeline in Mortandad Canyon (NPDES Outfall 051). The existing 6-inch outfall pipeline will be taken out of service.

Please contact me at (505) 667-7969 if you have any questions regarding this matter.

Sincerely,

A handwritten signature in blue ink that reads "Bob Beers".

Bob Beers  
Water Quality & Hydrology Group

An Equal Opportunity Employer / Operated by the University of California



: 02137

BB/jr

Enclosure: a/s

Cy: J. Davis, NMED/SWQB, Santa Fe, NM, w/enc.  
J. Parker, NMED/DOE/OB, Santa Fe, NM, w/enc.  
J. Vozella, DOE/OLASO, w/enc., MS A316  
G. Turner, DOE/OLASO, w/enc., MS A316  
D. McLain, FWO-WFM, w/enc., MS J593  
R. Alexander, FWO-WFM, w/enc., MS E518  
B. Ramsey, RRES-DO, w/enc., MS J591  
K. Hargis, RRES-DO, w/enc., MS J591  
T. George, RRES-DO, w/enc., MS J591  
D. Stavert, RRES-EP, w/enc., MS J591  
S. Rae, RRES-WQH, w/enc., MS K497  
D. Rogers, RRES-WQH, w/enc., MS K497  
M. Saladen, RRES-WQH, w/enc., MS K497  
D. Woitte, LC-ESH, w/enc., MS A187  
RRES-WQH File, w/enc., MS K497  
IM-5, w/enc., MS A150





BILL RICHARDSON  
GOVERNOR

State of New Mexico  
**ENVIRONMENT DEPARTMENT**

Ground Water Quality Bureau  
Harold Runnels Building  
1190 St. Francis Drive, P.O. Box 26110  
Santa Fe, New Mexico 87502-6110  
Telephone (505) 827-2918  
Fax (505) 827-2965



RON CURRY  
SECRETARY

DERRITH WATCHMAN-MOORE  
DEPUTY SECRETARY

**CERTIFIED MAIL RETURN RECEIPT REQUESTED**

DP-1132 (CF)

August 1, 2003

Mr. Ralph Erickson, Manager  
Office of Los Alamos Site Operations  
National Nuclear Security Administration  
US Dept. of Energy  
528 35th Street  
Los Alamos, New Mexico 87544

Dear Mr. Erickson:

Enclosed is a copy of the public notice pertaining to your proposed discharge plan(s) which is being published by the New Mexico Environment Department in a newspaper of general circulation.

If you have any questions, please do not hesitate to contact me at the address listed above or at 827-2900.

Sincerely,

*Maura Hanning*  
Maura Hanning, Program Manager  
Ground Water Pollution Prevention Section

MH:ds

Enclosures

<b>U.S. Postal Service</b>	
<b>CERTIFIED MAIL</b>	
<i>(Domestic Mail Only; No Ins)</i>	
7001 2510 0000 8014 7613	
Postage	\$
Certified Fee	
Return Receipt Fee (Endorsement Required)	
Restricted Delivery Fee (Endorsement Required)	
Mr. Ralph Erickson, Manager Office of Los Alamos Site National Nuclear Security US Dept. of Energy 528 35 <sup>th</sup> ST. Los Alamos, NM 87544	
PS Form 3800, January 2001	



BILL RICHARDSON  
GOVERNOR

State of New Mexico  
**ENVIRONMENT DEPARTMENT**

Ground Water Quality Bureau  
Harold Runnels Building  
1190 St. Francis Drive, P.O. Box 26110  
Santa Fe, New Mexico 87502-6110  
Telephone (505) 827-2918  
Fax (505) 827-2965



RON CURRY  
SECRETARY

DERRITH WATCHMAN-MOORE  
DEPUTY SECRETARY

**CERTIFIED MAIL - RETURN RECEIPT REQUESTED**

✓ DP-1132(CF)

August 1, 2003

Board of County Commissioners  
Los Alamos County  
P.O. Box 30  
Los Alamos, New Mexico 87544

Board of County Commissioners :

Enclosed is a copy of the public notice for one or more operations located in your county which is being published by the New Mexico Environment Department in a newspaper of general circulation.

If you have any questions, please do not hesitate to contact me at the address listed above or at 827-2900.

Sincerely,

Maura Hanning, Program Manager  
Ground Water Pollution Prevention Section

MH:ds

Enclosures



7001 2510 0000 8014 7958

Postage	\$
Certified Fee	
Return Receipt Fee (Endorsement Required)	
Restricted Delivery Fee (Endorsement Required)	

Board of County Commissio  
Los Alamos County  
P.O. Box 30  
Los Alamos, NM 87544

PS Form 3800, January 2001



NEW MEXICO ENVIRONMENT DEPARTMENT

Notice is hereby given that, pursuant to New Mexico Water Quality Control Commission Regulations, the following proposed ground water discharge permit(s) have been submitted for approval to the New Mexico Environment Department. The information in this notice generally has been supplied by the applicant and may or may not have been confirmed by the NM Environment Department.

**DP-181, CONTINENTAL MINE, NO. 1 MILL, NO. 2 MILL, MAIN TAILING POND, MAGNETITE TAILING POND, SOUTH WASTE ROCK DISPOSAL FACILITY,** John Fenn, Vice-President, Phelps Dodge New Mexico Operations, proposes to renew its discharge plan for the discharge of 12,000,000 gallons per day of tailing slurry from two crushing / flotation mills and 10,000 gallons per day of domestic waste to the Main Tailing Pond. The permit also includes the placement of all waste rock generated at the Continental Mine Facility in the South Waste Rock Disposal Facility. The Magnetite Tailing Pond is used to store magnetite and accepts intermittent discharges from the No. 2 Mill. The Pearson-Barnes Mine area, South and North Overburden Stockpiles, and former Hanover Empire Zinc Mine area at the Continental Mine Facility are also included in this permit. In addition, the Bullfrog/Hanover Pipeline system consists of steel tanks near the Bullfrog shaft and an eight inch steel pipeline to the Continental Mine and processing facilities. An HDPE pipeline also connects the steel tanks at the Bullfrog shaft with the Chino mine site. Up to 1,200,000 gallons of water per day can be transported via these pipelines. Seeps and storm water at the Continental Mine Site are collected and used in process water system. The Continental Mine Facility is located near Fierro in Sections 3, 4, 5, 8, 9, 10, 15, 16, 17, 20, 21, 29, 31, 32, T17S, R12W, Grant County. The renewal consists of a change of waste rock pile description as well as additions to the waste rock disposal facility. It includes the West, East, Buckhorn, and South Waste Rock Piles, as well as the low-grade ore stockpile in the area of the primary ore crusher and all waste rock stored south of the Main Tailing Impoundment to be named the South Waste Rock Disposal Facility. The South Waste Rock Pile Disposal Facility will accept waste rock material from the underground workings, the Continental Open Pit, and the Hanover Mountain Mine. Additionally, the storm water collection system on the Buckhorn Gulch and its tributaries south of the South Waste Rock Disposal Facility will be included in the South Waste Rock Pile Disposal Facility. Ground water below the site ranges in depth from 1 foot to 200 feet and has a total dissolved solids concentration in a range of 350 to 1,400 milligrams per liter.

**DP-281, ROSWELL WASTEWATER TREATMENT PLANT,** Art Torrez, Water Sewer Manager, proposes to modify the discharge permit for the discharge of 4,500,000 gallons per day of domestic waste. The facility is located east of Roswell in Sections 22, 23, 24, 25, 26, 34, 35 and 36, T10S, R24E, and Sections 29, 30, 31 and 32, T10S, R25E, Chaves County. Domestic wastewater from the City of Roswell is treated through two primary clarifiers, two trickling filters, two intermediate clarifiers, two second-stage trickling filters and a final clarifier. After final clarification, the effluent is disinfected by chlorination. The effluent will be transferred offsite via pipeline and land applied to approximately 1435 acres of cropland. The permit modification consists expanding the discharge locations from the existing 1000-acre land application area to include approximately 435 acres of additional cropland. Ground water most likely to be affected is at a depth of approximately 7 feet and has a total dissolved solids concentration of approximately 3000 milligrams per liter.

**DP-383, PHELPS DODGE, TYRONE, INC.,** John A. Fenn, Vice-President New Mexico Operations, proposes to renew its discharge permit for the discharge of 16,488,000 gallons per day (gpd) of leach solution to the No. 1B Leach Stockpile located at the Tyrone Mine Facility. Acidic leach solution is applied to the top of the stockpile and allowed to infiltrate through the ore material to extract metals. Up to 14,400,000 gpd of pregnant leach solution (PLS) is collected at the toe of the stockpile from surface impoundments, extraction wells and subsurface trenches. The PLS is transferred to above-ground steel storage tanks and then pumped to the solvent extraction/ electrowinning plant for processing. Primary contaminants associated with this type of

discharge include sulfate, TDS and several metals such as aluminum, cadmium, copper, iron and manganese. The facility is located 10 miles southwest of Silver City in Section 24, T19S, R15W, Grant County. Ground water most likely to be affected is at a depth of approximately 500 feet and has a total dissolved solids concentration of approximately 250 milligrams per liter.

**DP-435, PHELPS DODGE TYRONE, INC.,** John A. Fenn, Vice-President New Mexico Operations, proposes to renew and modify the discharge permit, which presently allows for the discharge of up to 12,000 gallons per minute of an acidic leach solution with a pH of 2 to the No. 2A Leach Stockpile. Leach solution is applied to the top of the stockpile to remove copper. The leach solution is collected at the base of the stockpile and transferred to a solvent extraction/electrowinning plant for processing. The proposed modification to this renewal includes increasing the discharge rate of leach solution to the No. 2A Leach Stockpile to 13,600 gallons per minute, placing leach ore from the Little Rock Mine on the 2A Leach Stockpile, and creating a new stockpile (9A Stockpile) consisting of waste rock from the Little Rock Mine. The 9A Stockpile will be located immediately northwest of the 2A Leach Stockpile and will not be leached. The facilities are located approximately 12 miles southwest of Silver City, New Mexico, in parts of Section 15, 16, 21, and 22, T19S, R15W, Grant County. Ground water below the permit discharge area ranges from approximately 180 to 210 feet and has a total dissolved solids concentration of approximately 250 to 880 milligrams per liter.

**DP-666, WESTERN STAR DAIRY,** Todd Teune, Owner, proposes to renew and modify the discharge permit for the discharge of 20,000 gallons per day of dairy wastewater from the Western Star Dairy. The facility is located 14 miles northwest from Portales in Section 7, T01S, R33E, Roosevelt County. Dairy wastewater is evaporated from one clay-lined and one synthetically lined lagoon, and may be land applied to 60 acres of irrigated cropland. The modification consists of decreasing the discharge from 49,950 gallons per day to 20,000 gallons per day, and decreasing the land application area from 170 acres to 60 acres. Ground water most likely to be affected is at a depth of approximately 90 feet and has a total dissolved solids concentration of approximately 1,500 milligrams per liter.

**DP-682, JOHNSON'S MOBILE HOME PARK #1,** Steve Calkins and Ahmad Hashemian, Owners, propose to renew and modify the discharge permit for the discharge of 12,500 gallons per day of domestic wastewater. The facility is located 3 miles from Las Cruces in Section 3, T24S, R02E, Doña Ana County. Up to 12,500 gallons per day of domestic wastewater from a mobile home park will be discharged from a septic tank leachfield system. The modification consists of reducing the discharge volume from 18,750 to 12,500 gallons per day. Ground water most likely to be affected is at a depth of approximately 110 feet and has a total dissolved solids concentration of approximately 250 milligrams per liter.

**DP-728, 4 DAUGHTERS LAND AND CATTLE COMPANY-LOS LUNAS FEEDLOT,** Mike Mechenbier, President, proposes to contain agricultural waste run-off from a cattle feedlot for a 24-hour, 25-year storm event. The facility is located in Los Lunas in Section 4, T06N, R02E, Valencia County. Storm water run-off is contained in a series of clay-lined lagoons for evaporation. Ground water most likely to be affected is at a depth of approximately 3 feet and has a total dissolved solids concentration of approximately 239 milligrams per liter.

**DP-988, BOYD BROTHERS INC. DAIRY,** Lee Boyd, Owner, proposes to renew and modify the discharge permit for the discharge of 3,000 gallons per day of dairy wastewater from the Boyd Brothers INC. Dairy. The facility is located 6 miles northeast from Lovington in Sections 34 and 35, T14S, R36E, Lea County. Dairy wastewater is collected in a sump and direct land applied by tanker truck to 640 acres of irrigated cropland. The modification consists of increasing the land application area from 34 to 640 acres of irrigated cropland including Section 35, T14S, R36E. Ground water most likely to be affected is at a depth of approximately 85 feet and has a total dissolved solids concentration of approximately 725 milligrams per liter.

**DP-1132, LOS ALAMOS NATIONAL LABORATORY, RADIOACTIVE LIQUID WASTE TREATMENT FACILITY (RLWTF)**, Ralph Erickson, U.S. Department of Energy, Office of Los Alamos Site Operations Manager, proposes to continue the discharge of up to 41,770 gallons per day of industrial effluent from the RLWTF. The facility is located approximately 1 mile south of the Town of Los Alamos at Technical Area 50, in Section 22, T19N, R6E, Los Alamos County. Radioactive liquid waste is conveyed to the RLWTF via double encased pipe, where it is treated by the following batch treatment process: raw and pretreated wastewater is collected in influent tanks prior to clarification. Clarified supernatant is then treated with a variety of filtration processes, followed by ion exchange. Effluent is either discharged to Mortandad Canyon, or receives further treatment by reverse osmosis (RO) prior to discharge. Reject from the RO unit receives further treatment via clarification followed by Electrodialysis Reversal (EDR). EDR product is routed to the RLWTF influent tanks where it reenters the treatment process, while EDR concentrate flows to an evaporator. Evaporator distillate is either discharged to Mortandad Canyon or held for further treatment. Evaporator distillate and RO permeate with tritium concentrations exceeding 20 nCi/L are trucked to Technical Area 53 for further treatment. Solids removed from the primary clarifier and the TUF unit are concentrated and dewatered prior to disposal at Technical Area 54 (TA-54), while filtrate from the dewatering of solids is routed to the RLWTF influent tanks where it reenters the treatment process. Evaporator bottoms are stabilized by off-site treatment prior to disposal at TA-54. The depth to alluvial ground water below the outfall in Mortandad Canyon is approximately 1 foot, and has a total dissolved solids concentration of approximately 320 milligrams per liter. The depth to regional ground water below the facility is approximately 970 feet, and has a total dissolved solids concentration of approximately 165 milligrams per liter.

**DP-1143, TAOS RIDGE TOWNHOUSES**, Mark Hirsch, Owner, proposes to renew and modify the discharge permit for the discharge of 4,500 gallons per day of domestic wastewater. The facility is located approximately 4 miles northwest of Taos, in the Antonio Martinez or Godoi Land Grant in projected Section 24, T26N, R12E, Taos County. Wastewater is treated in a 4,000 gallon septic tank followed by two parallel trickling filters coupled with a 1000 gallon recirculation tank, prior to disposal in a leachfield. The modification is to increase the permitted discharge volume from 2,700 gallons per day to 4,500 gallons per day. Ground water below the site is at a depth of approximately 160 ft and has a total dissolved solids concentration of approximately 187 milligrams per liter.

**DP-1163, NORTH POINT DAIRY**, Eddie Schaap, Owner, proposes to modify and renew the discharge permit for the discharge of 180,000 gallons per day of wastewater from a dairy. The facility is located 12 miles north of Clovis in Sections 15, 21, 22, 27 and 28, T4N, R36E, Curry County. Wastewater gravity flows from the parlor barn into the first clay-lined lagoon and is then pumped over a screen solids separator and collects in the second clay-lined lagoon. Wastewater is then land applied by center-pivot sprinkler irrigation to 1250 acres of irrigated cropland. The modification consists of increasing the land application area from 375 to 1250 acres. Ground water below the site is at a depth of approximately 380 feet and has a total dissolved solids concentration of approximately 260 milligrams per liter. The renewal was previously noticed on October 26, 2002, with 375 acres of land application area.

**DP-1168, GOFF DAIRY LLC**, Buster Goff, Owner, proposes to renew the discharge permit for the discharge of 160,000 gallons per day of dairy wastewater from the Goff Dairy LLC. The facility is located 10 miles south from Lovington in Sections 20 and 21, T17S, R37E, Lea County. Dairy wastewater is collected in a concrete sump, pumped to three clay-lined lagoons in series, and land applied to 320 acres of irrigated cropland. Ground water most likely to be affected is at a depth of approximately 60 feet and has a total dissolved solids concentration of approximately 450 to 650 milligrams per liter.

**DP-1289, RIVER RANCH RV PARK,** Tangela and Stelvin Sanderson, Owners, proposes to discharge up to 9,900 gallons per day of domestic wastewater. The facility is located 5 miles from Ruidoso Downs in Section 7, T11S, R15E, Lincoln County. Up to 9,900 gallons per day of domestic wastewater from the RV Park shall be discharged from a septic tank leachfield system. Ground water most likely to be affected is at a depth of approximately 12 feet and has a total dissolved solids concentration of approximately 1410 milligrams per liter.

Any interested person may obtain further information from the Ground Water Pollution Prevention Section of the NM Environment Department, telephone (505) 827-2900, and may submit written comments to the Ground Water Pollution Prevention Section, NM Environment Department, P.O. Box 26110, Santa Fe, NM 87502. Prior to ruling on any proposed discharge permit or its modification, the NM Environment Department will allow thirty (30) days after the date of publication of this notice to receive written comments and during which a public hearing may be requested by any interested person. Requests for public hearing shall set forth the reasons why the hearing should be held. A hearing will be held if the NM Environment Department determines that there is significant public interest.



Jerry in 6wqB

AUG 11 2003



*Risk Reduction & Environmental Stewardship Division*  
*Water Quality & Hydrology Group (RRES-WQH)*  
PO Box 1663, MS K497  
Los Alamos, New Mexico 87545  
(505) 667-7969/Fax: (505) 665-9344

Date: July 30, 2003  
Refer to: RRES-WQH: 03-169

Mr. Curt Frischkorn  
Ground Water Pollution Prevention Section  
Ground Water Quality Bureau  
New Mexico Environment Department  
P.O. Box 26110  
Santa Fe, New Mexico 87502

**SUBJECT: TA-50 RADIOACTIVE LIQUID WASTE TREATMENT FACILITY, GROUND WATER DISCHARGE PLAN (DP-1132) QUARTERLY REPORT, SECOND QUARTER 2003**

Dear Mr. Frischkorn:

This letter is intended to serve as Los Alamos National Laboratory's quarterly Ground Water Discharge Plan (DP-1132) report for the TA-50 Radioactive Liquid Waste Treatment Facility (RLWTF) for the 2<sup>nd</sup> quarter of 2003. Since the first quarter of 1999, Los Alamos National Laboratory has provided your agency with voluntary quarterly reports containing analytical results from effluent and ground water monitoring.

Mortandad Canyon Alluvial Ground Water Monitoring Results

Table 1.0 presents the analytical results from sampling conducted at four Mortandad Canyon alluvial monitoring wells (MCO-4B, MCO-5, MCO-6, and MCO-7) during the 2<sup>nd</sup> quarter of 2003 and one well (MCO-3) sampled during the 3<sup>rd</sup> quarter of 2003. The analytical results from the June 2, 2003, sampling of MCO-3 were invalidated due to an apparent analytical error; the data suggests that deionized water, commonly used in the preparation of QC blanks, was analyzed in lieu of a real ground water sample. As a result, MCO-3 was resampled in the 3<sup>rd</sup> quarter as soon as the error became evident.

All of the analytical results from MCO-3, MCO-4B, MCO-5, MCO-6, and MCO-7 were below New Mexico Water Quality Control Commission (NM WQCC) Regulation 3103 standards for nitrate-nitrogen (NO<sub>3</sub>-N), fluoride (F), and total dissolved solids (TDS).

RLWTF Effluent Monitoring Results

Table 2.0 presents the analytical results from weekly monitoring of the RLWTF's effluent. The weekly samples are flow-proportioned composite samples prepared from each tank of effluent generated by the RLWTF during a 7-day period. Samples are submitted to General Engineering Laboratories (GEL), Charleston, SC, for analysis. All sample results from the 2<sup>nd</sup> quarter were below NM WQCC Regulation 3103 standards for NO<sub>3</sub>-N, F, and TDS with the exception of a single excursion for fluoride in March of 1.64 mg/L. The RLWTF, in accordance with its administrative procedures, collected an operational sample for fluoride from each batch of effluent discharge during the week of March 17-23. Fluoride concentrations from operational sampling of the four effluent batches discharged during this period are as follows: 1.33 mg/L, 1.0 mg/L, 1.52 mg/L, and 1.12 mg/L. In addition, RLWTF analysis of the same weekly composite sample submitted to GEL showed a fluoride concentration of 1.45 mg/L (+/- 0.1 mg/L). In sum, all RLWTF operational results indicate that effluent discharged during this period was in compliance with the NM WQCC ground water standard for fluoride.

As presented in Table 2.0, the 2<sup>nd</sup> quarter average for fluoride in the RLWTF's effluent was 0.42 mg/L. Low fluoride concentrations in the RLWTF's effluent were achieved during May and June through the consistent use of the facility's RO treatment unit.

Please contact me at (505) 667-7969 if you would like additional information regarding this quarterly report.

Sincerely,



Bob Beers  
Water Quality & Hydrology Group

BB/tml

Cy: M. Leavitt, NMED/SWQB, Santa Fe, NM  
S. Yanicak, NMED/DOE/OB, Santa Fe, NM  
R. Ford-Schmid, NMED/DOE/OB, Santa Fe, NM  
J. Vozella, DOE/OLASO, MS A316  
G. Turner, DOE/OLASO, MS A316  
J. Holt, ADO, MS A104  
T. Stanford, FWO-DO, MS K492  
D. McLain, FWO-WFM, MS J593  
R. Alexander, FWO-WFM, MS E518  
D. Moss, FWO-WFM, MS E518  
P. Worland, FWO-WFM, MS E518  
B. McClenahan, FWO-WFM, MS E518  
B. Ramsey, RRES-DO, MS J591

Mr. Curt Frischkorn  
RRES-WQH:03-169

- 3 -

July 30, 2003

Cy (continued):

K. Hargis, RRES-DO, MS J591  
T. George, RRES-DO, MS J591  
D. Stavert, RRES-EP, MS J591  
S. Rae, RRES-WQH, MS K497  
D. Rogers, RRES-WQH, MS K497  
M. Saladen, RRES-WQH, MS K497  
RRES-WQH File, MS K497  
IM-5, MS A150



*Radioactive Liquid Waste Treatment Facility  
Ground Water Discharge Plan (DP-1132) Quarterly Report  
2nd Quarter, 2003*

**Table 1.0. Mortandad Canyon Alluvial Monitoring Wells Analytical Results, 2nd Quarter, 2003.**

Sampling Location	Sample Date	Perchlorate <sup>4</sup> (ug/L)	NO3/NO2-N (mg/L)	TKN (mg/L)	NH3-N (mg/L)	TDS (mg/L)	F (mg/L)
MCO-3	7/10/2003 <sup>3</sup>	<0.989	2.17	0.30	<0.050	318	0.786
MCO-4B	6/2/2003	20.5	2.78	0.38	<0.050	399	0.972
MCO-5	6/2/2003	27.7	2.69	0.42	<0.050	399	0.937
MCO-6	6/3/2003	37.4	2.72	0.32	<0.050	386	1.11
MCO-7	6/3/2003	84.8	4.08	0.36	<0.050	327	1.35
<i>NM WQCC 3103. Ground Water Standards (mg/L)</i>			<i>10<sup>2</sup></i>			<i>1000</i>	<i>1.6</i>

**Notes:**

<sup>1</sup>NS means that there was not sufficient water available for sampling.

<sup>2</sup>The NMWQCC Regulation 3103. Ground Water Standard is for NO<sub>3</sub>-N.

<sup>3</sup>Resample results were collected outside of quarter. Initial results, collected on 6/2/03, were invalidated due to sampler error.

<sup>4</sup>Nonfiltered sample.

J indicates an estimated value. The result was less than the reporting limit, but greater than the detection limit.

All analyses by General Engineering Laboratories, Charleston, SC.

All samples filtered unless otherwise noted.

02151

Radioactive Liquid Waste Treatment Facility  
 Ground Water Discharge Plan (DP-1132) Quarterly Report  
 2nd Quarter, 2003

Table 2.0. RLWTF Weekly Effluent Monitoring Analytical Results, 2nd Quarter, 2003.

Monitoring Period	Composite Date	RLWTF Weekly Effluent Monitoring Analytical Results (mg/L)		
		NO <sub>3</sub> +NO <sub>2</sub> -N	Fluoride	TDS
<u>MARCH, 2002</u>	3/25/2003	1.66	1.64	514
<u>APRIL, 2003</u>	4/1/2003	1.27	1.12	310
	4/8/2003	0.94	0.68	214
	4/15/2003	0.47	0.43	215
	4/24/2003	0.29	0.35	209
	<u>MAY, 2003</u>	5/6/2003	0.15	<0.1
<u>MAY, 2003</u>	5/13/2003	0.19	<0.1	24
	5/21/2003	0.19	0.21	64
	5/28/2003	0.03	<0.1	93
	<u>JUNE, 2003</u>	6/3/2003	0.06	0.13
<u>JUNE, 2003</u>	6/10/2003	0.01	<0.1	85
	6/17/2003	<0.05	<0.1	36
	6/24/2003	pending	pending	pending
	<b>2nd Quarter 2003 Averages (mg/L)</b>		<b>0.44</b>	<b>0.42</b>
<i>NM WQCC 3103. Ground Water Standards (mg/L)</i>		<i>10.0<sup>4</sup></i>	<i>1.6</i>	<i>1000</i>

**Notes:**

<sup>1</sup>Results for these analyses are pending validation.

<sup>2</sup>A duplicate sample result.

<sup>4</sup>The NMWQCC Regulation 3103. Ground Water Standard is for NO<sub>3</sub>-N

All analyses by the General Engineering Laboratories, Charleston, South Carolina.

: 02152





BILL RICHARDSON  
GOVERNOR

State of New Mexico  
**ENVIRONMENT DEPARTMENT**

Ground Water Quality Bureau

Harold Runnels Building

1190 St. Francis Drive, P.O. Box 26110

Santa Fe, New Mexico 87502-6110

Telephone (505) 827-2918

Fax (505) 827-2965



U.S. Postal Service  
**CERTIFIED MAIL**  
(Domestic Mail Only; No Ins)

**CERTIFIED MAIL – RETURN RECEIPT REQUESTED**

August 11, 2003

Kathy Sanchez, President  
Pi'ee Quiyo Inc.  
Rt. 5, Box 442-B  
San Ildefonso Pueblo  
Santa Fe, New Mexico 87506

Dear Ms. Sanchez:

Enclosed is a copy of the public notice pertaining to the proposed ground water discharge permit for Los Alamos National Laboratory's Radioactive Liquid Waste Treatment Facility. The public notice is being published by the New Mexico Environment Department in the Albuquerque Journal and the Los Alamos Monitor on approximately August 8, 2003.

Any interested person may obtain further information from the Ground Water Pollution Prevention Section of the New Mexico Environment Department, telephone (505) 827-2900, and may submit written comments to the Ground Water Pollution Prevention Section, New Mexico Environment Department, P.O. Box 26110, Santa Fe, NM 87502. Prior to ruling on any proposed discharge permit or its modification, the New Mexico Environment Department will allow thirty (30) days after the date of publication of this notice to receive written comments, during which a public hearing may be requested by any interested person. Requests for public hearing shall set forth the reasons why the hearing should be held. A hearing will be held if the NM Environment Department determines that there is significant public interest.

You are being provided with a copy of this public notice because of correspondence received by you in response to the initial public notice for this facility, which was published in November, 1996. Please provide written comment if you wish to request a public hearing at this time, or contact Curt Frischkorn of the Ground Water Pollution Prevention Section at (505) 827-0078 if you have any questions.

Sincerely,

Maura Hanning, Program Manager  
Ground Water Pollution Prevention Section

DER  
8238  
8014  
8000  
0000  
0152  
2510  
700J

Postage	\$
Certified Fee	
Return Receipt Fee (Endorsement Required)	
Restricted Delivery Fee (Endorsement Required)	
Total Postage & Fees	\$

Kathy Sanchez, Pres  
Pi'ee Quiyo, Inc.  
Rt. 5, Box 442-B  
San Ildefonso Pueblo  
Santa Fe, New Mexico



BILL RICHARDSON  
GOVERNOR

State of New Mexico  
**ENVIRONMENT DEPARTMENT**

Ground Water Quality Bureau

Harold Runnels Building

1190 St. Francis Drive, P.O. Box 26110

Santa Fe, New Mexico 87502-6110

Telephone (505) 827-2918

Fax (505) 827-2965



U.S. Postal Service  
**CERTIFIED MAIL**  
(Domestic Mail Only; No Ins)

**CERTIFIED MAIL – RETURN RECEIPT REQUESTED**

August 11, 2003

Susan Diane  
P.O. Box 9855  
Santa Fe, New Mexico 87504

Dear Ms. Diane:

Enclosed is a copy of the public notice pertaining to the proposed ground water discharge permit for Los Alamos National Laboratory's Radioactive Liquid Waste Treatment Facility. The public notice is being published by the New Mexico Environment Department in the Albuquerque Journal and the Los Alamos Monitor on approximately August 8, 2003.

Any interested person may obtain further information from the Ground Water Pollution Prevention Section of the New Mexico Environment Department, telephone (505) 827-2900, and may submit written comments to the Ground Water Pollution Prevention Section, New Mexico Environment Department, P.O. Box 26110, Santa Fe, NM 87502. Prior to ruling on any proposed discharge permit or its modification, the New Mexico Environment Department will allow thirty (30) days after the date of publication of this notice to receive written comments, during which a public hearing may be requested by any interested person. Requests for public hearing shall set forth the reasons why the hearing should be held. A hearing will be held if the NM Environment Department determines that there is significant public interest.

You are being provided with a copy of this public notice because of correspondence received by you in response to the initial public notice for this facility, which was published in November, 1996. Please provide written comment if you wish to request a public hearing at this time, or contact Curt Frischkorn of the Ground Water Pollution Prevention Section at (505) 827-0078 if you have any questions.

Sincerely,

Maura Hanning, Program Manager  
Ground Water Pollution Prevention Section

DI 8221  
8014 8221  
0000 0000  
0510 0000  
7001 2510

Postage	\$
Certified Fee	
Return Receipt Fee (Endorsement Required)	
Restricted Delivery Fee (Endorsement Required)	
<b>Total Postage &amp; Fees</b>	<b>\$</b>
Sent To <b>Susan Diane</b>	
P.O. Box 9855	
Santa Fe, New Mexico	
City, State, ZIP+4	
PS Form 3800, January 2003	



BILL RICHARDSON  
GOVERNOR

State of New Mexico  
**ENVIRONMENT DEPARTMENT**

Ground Water Quality Bureau  
Harold Runnels Building  
1190 St. Francis Drive, P.O. Box 26110  
Santa Fe, New Mexico 87502-6110  
Telephone (505) 827-2918  
Fax (505) 827-2965



U.S. Postal Service  
**CERTIFIED MAIL**  
(Domestic Mail Only; No In...

**CERTIFIED MAIL – RETURN RECEIPT REQUESTED**

August 11, 2003

Douglas Meiklejohn  
New Mexico Environmental Law Center  
1405 Luisa Street, Suite 5  
Santa Fe, New Mexico 87505

Dear Mr. Meiklejohn:

Enclosed is a copy of the public notice pertaining to the proposed ground water discharge permit for Los Alamos National Laboratory's Radioactive Liquid Waste Treatment Facility. The public notice is being published by the New Mexico Environment Department in the Albuquerque Journal and the Los Alamos Monitor on approximately August 8, 2003.

Any interested person may obtain further information from the Ground Water Pollution Prevention Section of the New Mexico Environment Department, telephone (505) 827-2900, and may submit written comments to the Ground Water Pollution Prevention Section, New Mexico Environment Department, P.O. Box 26110, Santa Fe, NM 87502. Prior to ruling on any proposed discharge permit or its modification, the New Mexico Environment Department will allow thirty (30) days after the date of publication of this notice to receive written comments, during which a public hearing may be requested by any interested person. Requests for public hearing shall set forth the reasons why the hearing should be held. A hearing will be held if the NM Environment Department determines that there is significant public interest.

You are being provided with a copy of this public notice because of correspondence received by you in response to the initial public notice for this facility, which was published in November, 1996. Please provide written comment if you wish to request a public hearing at this time, or contact Curt Frischkorn of the Ground Water Pollution Prevention Section at (505) 827-0078 if you have any questions.

Sincerely,

Maura Hanning, Program Manager  
Ground Water Pollution Prevention Section

DERRI

7001 2510 0000 8014 8207

Postage	\$
Certified Fee	
Return Receipt Fee (Endorsement Required)	
Restricted Delivery Fee (Endorsement Required)	
Total Postage & Fees	\$

Sent To: Douglas Meiklejohn  
NM Environmental L  
1405 Luisa St., Su  
Santa Fe, New Mexi

Form 3800 January 2001



BILL RICHARDSON  
GOVERNOR

State of New Mexico  
**ENVIRONMENT DEPARTMENT**

Ground Water Quality Bureau  
Harold Runnels Building  
1190 St. Francis Drive, P.O. Box 26110  
Santa Fe, New Mexico 87502-6110  
Telephone (505) 827-2918  
Fax (505) 827-2965



U.S. Postal Service  
**CERTIFIED MAIL**  
(Domestic Mail Only; No Ins)

**CERTIFIED MAIL – RETURN RECEIPT REQUESTED**

August 11, 2003

Joey Natseway  
Tewa Women United  
Rt. 5, Box 298  
Santa Fe, New Mexico 87506

Dear Ms. Natseway:

Enclosed is a copy of the public notice pertaining to the proposed ground water discharge permit for Los Alamos National Laboratory's Radioactive Liquid Waste Treatment Facility. The public notice is being published by the New Mexico Environment Department in the Albuquerque Journal and the Los Alamos Monitor on approximately August 8, 2003.

Any interested person may obtain further information from the Ground Water Pollution Prevention Section of the New Mexico Environment Department, telephone (505) 827-2900, and may submit written comments to the Ground Water Pollution Prevention Section, New Mexico Environment Department, P.O. Box 26110, Santa Fe, NM 87502. Prior to ruling on any proposed discharge permit or its modification, the New Mexico Environment Department will allow thirty (30) days after the date of publication of this notice to receive written comments, during which a public hearing may be requested by any interested person. Requests for public hearing shall set forth the reasons why the hearing should be held. A hearing will be held if the NM Environment Department determines that there is significant public interest.

You are being provided with a copy of this public notice because of correspondence received by you in response to the initial public notice for this facility, which was published in November, 1996. Please provide written comment if you wish to request a public hearing at this time, or contact Curt Frischkorn of the Ground Water Pollution Prevention Section at (505) 827-0078 if you have any questions.

Sincerely,

Maura Hanning, Program Manager  
Ground Water Pollution Prevention Section

DE 8214  
8214  
8014  
0000  
0000  
0520  
2510  
7001

Postage	\$
Certified Fee	
Return Receipt Fee (Endorsement Required)	
Restricted Delivery Fee (Endorsement Required)	
Total Postage & Fees	\$

Send to  
**Joey Natseway**  
**Tewa Women United**  
Rt. 5 Box 298  
Santa Fe, New Mexico

PS Form 3800 January 2001



BILL RICHARDSON  
GOVERNOR

*State of New Mexico*  
**ENVIRONMENT DEPARTMENT**

*Ground Water Quality Bureau*

*Harold Runnels Building*

*1190 St. Francis Drive, P.O. Box 26110*

*Santa Fe, New Mexico 87502-6110*

*Telephone (505) 827-2918*

*Fax (505) 827-2965*



U.S. Postal Service  
**CERTIFIED MAIL**  
(Domestic Mail Only; No Ins)

DER 5429 8245  
4108 8014  
0000 0000  
0752 0007  
7007 2510

**CERTIFIED MAIL – RETURN RECEIPT REQUESTED**

August 11, 2003

Joni Arends, Waste Programs Director  
Concerned Citizens for Nuclear Safety  
107 Cienega  
Santa Fe, New Mexico 87501

Dear Ms. Arends:

Enclosed is a copy of the public notice pertaining to the proposed ground water discharge permit for Los Alamos National Laboratory's Radioactive Liquid Waste Treatment Facility. The public notice is being published by the New Mexico Environment Department in the Albuquerque Journal and the Los Alamos Monitor on approximately August 8, 2003.

Any interested person may obtain further information from the Ground Water Pollution Prevention Section of the New Mexico Environment Department, telephone (505) 827-2900, and may submit written comments to the Ground Water Pollution Prevention Section, New Mexico Environment Department, P.O. Box 26110, Santa Fe, NM 87502. Prior to ruling on any proposed discharge permit or its modification, the New Mexico Environment Department will allow thirty (30) days after the date of publication of this notice to receive written comments, during which a public hearing may be requested by any interested person. Requests for public hearing shall set forth the reasons why the hearing should be held. A hearing will be held if the NM Environment Department determines that there is significant public interest.

You are being provided with a copy of this public notice because of correspondence received by you in response to the initial public notice for this facility, which was published in November, 1996. Please provide written comment if you wish to request a public hearing at this time, or contact Curt Frischkorn of the Ground Water Pollution Prevention Section at (505) 827-0078 if you have any questions.

Sincerely,

Maura Hanning, Program Manager  
Ground Water Pollution Prevention Section

Postage	\$
Certified Fee	
Return Receipt Fee (Endorsement Required)	
Restricted Delivery Fee (Endorsement Required)	
<b>Total Postage &amp; Fees</b>	<b>\$</b>
Sent To <b>Joni Arends, Program Manager Concerned Citizens for Nuclear Safety 107 Cienega Santa Fe, New Mexico</b>	





AFFIDAVIT OF PUBLICATION

RECEIVED

AUG 22 2003

CHRIS DISSINGER, being duly sworn, declares that he is the PUBLISHER/  
GENERAL MANAGER of the Los Alamos Monitor, a newspaper published and  
having a general fully paid circulation and second-class postal privilege in the  
County of Los Alamos, State of New Mexico.

Affiant further states that this newspaper is duly qualified to publish legal notices  
or advertisements within the meaning of Section 14-11 N.M.S.A., 1978  
Compilation and was so qualified at the time of all publications in reference  
hereto.

Affiant further states that the publication, a copy of which hereto affixed, was  
published in said paper, in the regular and entire issue of each number of the  
paper, during the period and time of publication and that the notice was  
published

on the newspaper proper and not in a supplement, for 1 Consecutive weeks,  
the first publication being on the 7<sup>th</sup> day of August, 2003,  
and the subsequent publications on \_\_\_\_\_,

and \_\_\_\_\_

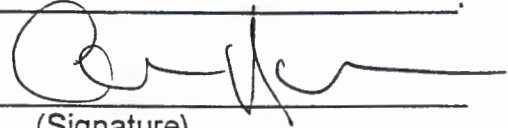
  
(Signature)

Subscribed and sworn before me this 19<sup>th</sup> day of August,  
2003.

Rowena Plonski  
Notary Public

My Commission Expires: Oct 4, 2006

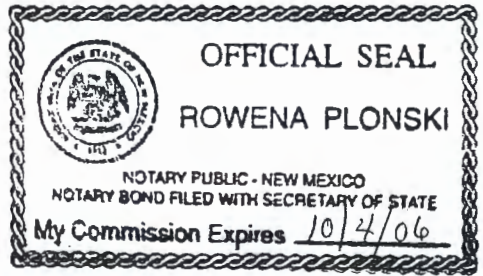

NEW MEXICO ENVIRONMENT  
DEPARTMENT

Notice is hereby given that, pursuant to New Mexico Water Quality Control Commission Regulations, the following proposed ground water discharge permit(s) have been submitted for approval to the New Mexico Environment Department. The information in this notice generally has been supplied by the applicant and may or may not have been confirmed by the NM Environment Department.

DP-1132, LOS ALAMOS NATIONAL LABORATORY, RADIOACTIVE LIQUID WASTE TREATMENT FACILITY (RLWTF), Ralph Erickson, U.S. Department of Energy, Office of Los Alamos Site Operations Manager, proposes to continue the discharge of up to 41,770 gal-

lons per day of industrial effluent from the RLWTF. The facility is located approximately 1 mile south of the Town of Los Alamos at Technical Area 50, in Section 22, T19N, R6E, Los Alamos County. Radioactive liquid waste is conveyed to the RLWTF via double encased pipe, where it is treated by the following batch treatment process: raw and pre-treated wastewater is collected in influent tanks prior to clarification. Clarified supernatant is then treated with a variety of filtration processes, followed by ion exchange. Effluent is either discharged to Mortandad Canyon, or receives further treatment by reverse osmosis (RO) prior to discharge. Reject from the RO unit receives further treatment via clarification followed by Electrodialysis Reversal (EDR). EDR product is routed to the RLWTF influent tanks where it reenters the treatment process, while EDR concentrate flows to an evaporator. Evaporator distillate is

either discharged to Mortandad Canyon or held for further treatment. Evaporator distillate and RO permeate with tritium concentrations exceeding 20 nCi/L are trucked to Technical Area 53 for further treatment. Solids removed from the primary clarifier and the TUF unit are concentrated and dewatered prior to disposal at Technical Area 54 (TA-54), while filtrate from the dewatering of solids is routed to the RLWTF influent tanks where it reenters the treatment process. Evaporator bottoms are stabilized by off-site treatment prior to disposal at TA-54. The depth to alluvial ground water below the outfall in Mortandad Canyon is approximately 1 foot, and has a total dissolved solids concentration of approximately 320 milligrams per liter. The depth to regional ground water below the facility is approximately 970 feet, and has a total dissolved solids concentration of approximately 165 milligrams per liter.

Any interested person may obtain further information from the Ground Water Pollution Prevention Section of the NM Environment Department, telephone (505) 827-2900, and may submit written comments to the Ground Water Pollution Prevention Section, NM Environment Department, P.O. Box 26110, Santa Fe, NM 87502. Prior to ruling on any proposed discharge permit or its modification, the NM Environment Department will allow thirty (30) days after the date of publication of this notice to receive written comments and during which a public hearing may be requested by any interested person. Requests for public hearing shall set forth the reasons why the hearing should be held. A hearing will be held if the NM Environment Department determines that there is significant public interest.

Date of Publication: \_\_\_\_\_

STATE OF NEW MEXICO  
County of Bernalillo SS

Bill Tafoya, being duly sworn, declares and says that he is Classified Advertising Manager of The Albuquerque Journal, and that this newspaper is duly qualified to publish legal notices or advertisements within the meaning of Section 3, Chapter 167, Session Laws of 1937, and that payment therefore has been made of assessed as court cost; that the notice, copy of which is hereto attached, was published in said paper in the regular daily edition, for 4 times, the first publication being on the 4 day of August, 2003, and the subsequent consecutive publications on \_\_\_\_\_, 2003.

NEW MEXICO  
ENVIRONMENT DEPARTMENT

Notice is hereby given that, pursuant to New Mexico Water Quality Control Commission Regulations, the following proposed ground water discharge permit(s) have been submitted for approval to the New Mexico Environment Department. The information in this notice generally has been supplied by the applicant and may or may not have been confirmed by the NM Environment Department.

DP-181, CONTINENTAL MINE, NO. 1 MILL, NO. 2 MILL, MAIN TAILING POND, MAGNETITE TAILING POND, SOUTH WASTE ROCK DISPOSAL FACILITY, John Fenn, Vice-President, Phelps Dodge New Mexico Operations, proposes to renew its discharge permit for the discharge of 12,000,000 gallons per day of tailing slurry from two crushing / flotation mills and 10,000 gallons per day of domestic waste to the Main Tailing Pond. The permit also includes the placement of all waste rock generated at the Continental Mine Facility in the South Waste Rock Disposal Facility. The Magnetite Tailing Pond is used to store magnetite and accepts intermittent discharges from the No. 2 Mill, The Pearson-Barnes Mine area, South and North Overburden Stockpiles, and former Hanover Empire Zinc Mine area at the Continental Mine Facility are also included in this permit. In addition, the Bullfrog/Hanover Pipeline system consists of steel tanks near the Bullfrog shaft and an eight inch steel pipeline to the Continental Mine and processing facilities. An HDPE pipeline also connects the steel tanks at the Bullfrog shaft with the Chino mine site. Up to 2,000,000 gallons of water per day can be transported via these pipelines. Seeps and storm water at the Continental Mine Site are collected and used in process water system. The Continental Mine Facility is located near Fiero in Sections 3, 4, 6, 9, 10, 15, 16, 17, 20, 21, 29, 31, 32, T17S, R12W, Grant County. The renewal consists of a change of waste rock pile description as well as additions to the waste rock disposal facility. It includes the West, East, Buckhorn, and South Waste Rock Piles, as well as the w-grade ore stockpile in the area of the primary ore crusher and all waste rock stored south of the Main Tailing Impoundment to be named the South Waste Rock Disposal Facility. The South Waste Rock Disposal Facility will accept waste rock material from the underground workings, the Continental Open Pit, and the Hanover Mountain Mine. Additionally, the storm water collection system on the Buckhorn Gulch and its tributaries south of the South Waste Rock Disposal Facility will be included in the South Waste Rock Disposal Facility. Ground water below the site ranges in depth from 1 foot to 200 feet and has a total dissolved solids concentration in a range of 350 to 1,400 milligrams per liter.

DP-281, ROSWELL WASTEWATER TREATMENT PLANT, Art Torrez, Water Sewer Manager, proposes to modify the discharge permit for the discharge of 4,500,000 gallons per day of domestic waste. The facility is located east of Roswell in Sections 22, 23, 24, 25, 26, 34, 35 and 36, T10S, R24E, and Sections 29, 30, 31 and 32, T10S, R25E, Chaves County. Domestic wastewater from the City of Roswell is treated through two primary clarifiers, two trickling filters, two intermediate clarifiers, two second-stage trickling filters and a final clarifier. After final clarification, the effluent is disinfected by chlorination. The effluent will be transferred offsite via pipeline and land applied to approximately 1435 acres of cropland. The permit modification consists expanding the discharge locations from the existing 1000-acre land application area to include approximately 435 acres of additional cropland. Ground water most likely to be affected is at a depth of approximately 7 feet and has a total dissolved solids concentration of approximately 3000 milligrams per liter.

DP-383, PHELPS DODGE TYRONE, INC., John A. Fenn, Vice-President New Mexico Operations, proposes to renew its discharge permit for the discharge of 16,488,000 gallons per day (gpd) of leach solution to the No. 1B Leach Stockpile located at the Tyrone Mine Facility. Acidic leach solution is applied to the top of the stockpile and allowed to infiltrate through the ore material to extract metals. Up to 14,400,000 gpd of pregnant leach solution (PLS) is collected at the toe of the stockpile from surface impoundments, extraction wells and subsurface trenches. The PLS is transferred to above-ground steel storage tanks and then pumped to the solvent extraction/electrowinning plant for processing. Primary contaminants associated with this type of discharge include sulfate, TDS and several metals such as aluminum, cadmium, copper, iron and manganese. The facility is located 10 miles southwest of Silver City in Section 24, T19S, R15W, Grant County. Ground water most likely to be affected is at a depth of approximately 500 feet and has a total dissolved solids concentration of approximately 250 milligrams per liter.

DP-435, PHELPS DODGE TYRONE, INC., John A. Fenn, Vice-President New Mexico Operations, proposes to renew and modify the discharge permit, which presently allows for the discharge of up to 12,000 gallons per minute of an acidic leach solution with a pH of 2 to the No. 2A Leach Stockpile. Leach solution is applied to the top of the stockpile to remove copper. The leach solution is collected at the base of the stockpile and transferred to a solvent extraction/electrowinning plant for processing. The proposed modification to this renewal includes increasing the discharge rate of leach solution to the No. 2A Leach Stockpile to 13, 600 gallons per minute, placing leach ore from the Little Rock Mine on the 2A Leach Stockpile, and creating a new stockpile (9A Stockpile) consisting of waste rock from the Little Rock Mine. The 9A Stockpile will be located immediately northwest of the 2A Leach Stockpile and will not be leached. The facilities are located approximately 12 miles southwest of Silver City, New Mexico, in parts of Section 15, 16, 21, and 22, T19S, R15W, Grant County. Ground water below the permit discharge area ranges from approximately 180 to 210 feet and has a total dissolved solids concentration of approximately 250 to 880 milligrams per liter.

DP-666, WESTERN STAR DAIRY, Todd Teune, Owner, proposes to renew and modify the discharge permit for the discharge of 20,000 gallons per day of dairy wastewater from the Western Star Dairy. The facility is located 14 miles northwest from Portales in Section 7, T01S, R33E, Roosevelt County. Dairy wastewater is evaporated from one clay-lined and one synthetically lined lagoon, and may be land applied to 60 acres of irrigated cropland. The modification consists of decreasing the discharge from 49,950 gallons per day to 20,000 gallons per day, and decreasing the land application area from 170 acres to 60 acres. Ground water most likely to be affected is at a depth of approximately 90 feet and has a total dissolved solids concentration of approximately 1,500 milligrams per liter.

DP-682, JOHNSON'S MOBILE HOME PARK #1, Steve Calkins and Ahmad Hashemian, Owners, propose to renew and modify the discharge permit for the discharge of 12,500 gallons per day of domestic wastewater. The facility is located 3 miles from Las Cruces in Section 3, T24S, R02E, Dona Ana County. Up to 12,500 gallons per day of domestic wastewater from a mobile home park will be discharged from a septic tank leachfield system. The modification consists of reducing the discharge volume from 18,750 to 12,500 gallons per day. Ground water most likely to be affected is at a depth of approximately 110 feet and has a total dissolved solids concentration of approximately 250 milligrams per liter.

DP-728, 4 DAUGHTERS LAND AND CATTLE COMPANY-LOS LUNAS FEEDLOT, Mike Mechenthaler, President, proposes to contain agricultural waste run-off from a cattle feedlot for a 24-hour, 25-year storm event. The facility is located in Los Lunas in Section 4, T06N, R02E, Valencia County. Storm water run-off is contained in a series of clay-lined lagoons for evaporation. Ground water most likely to be affected is at a depth of approximately 3 feet and has a total dissolved solids concentration of approximately 239 milligrams per liter.

DP-988, BOYD BROTHERS INC. DAIRY, Lee Boyd, Owner, proposes to renew and modify the discharge permit for the discharge of 3,000 gallons per day of dairy wastewater from the Boyd Brothers Inc. Dairy. The facility is located 6 miles northeast from Lovington in Sections 34 and 35, T14S, R36E, Lea County. Dairy wastewater is collected in a sump and direct land applied by tanker truck to 640 acres of irrigated cropland. The modification consists of increasing the land application area from 34 to 640 acres of irrigated cropland including Section 35, T14S, R36E. Ground water most likely to be affected is at a depth of approximately 85 feet and has a total dissolved solids concentration of approximately 725 milligrams per liter.

DP-1132, LOS ALAMOS NATIONAL LABORATORY, RADIOACTIVE LIQUID WASTE TREATMENT FACILITY (RLWTF), Ralph Erickson, U.S. Department of Energy, Office of Los Alamos Site Operations Manager, proposes to continue the discharge of up to 41,770 gallons per day of industrial effluent from the RLWTF. The facility is located approximately 1-mile south of the Town of Los Alamos at Technical Area 50, in Section 22, T19N, R6E, Los Alamos County. Radioactive liquid waste is conveyed to the RLWTF via double encased pipe, where it is treated by the following batch treatment process: raw and pretreated wastewater is collected in influent tanks prior to clarification. Clarified supernatant is then treated with a variety of filtration processes, followed by ion exchange. Effluent is either discharged to Mortandad Canyon, or receives further treatment by reverse osmosis (RO) prior to discharge. Reject from the RO unit receives further treatment via clarification followed by Electrodeionolysis Reversal (EDR). EDR product is routed to the RLWTF influent tanks where it reenters the treatment process, while EDR concentrate flows to an evaporator. Evaporator distillate is either discharged to Mortandad Canyon or held for further treatment. Evaporator distillate and RO permeate with tritium concentrations exceeding 20 nCi/L are trucked to Technical Area 53 for further treatment. Solids removed from the primary clarifier and de-watered prior to disposal at Technical Area 54 (TA-54), while filtrate from the dewatering of solids is routed to the RLWTF influent tanks where it reenters the treatment process. Evaporator bottoms are stabilized by off-site treatment prior to disposal at TA-54. The depth to alluvial ground water below the outfall in Mortandad Canyon is approximately 1 foot, and has a total dissolved solids concentration of approximately 320 milligrams per liter. The depth to regional ground water below the facility is approximately 970 feet, and has a total dissolved solids concentration of approximately 165 milligrams per liter.

DP-1143, TAOS RIDGE TOWNHOUSES, Mark Hirsch, Owner, proposes to renew and modify the discharge permit for the discharge of 4,500 gallons per day of domestic wastewater. The facility is located approximately 4 miles northwest of Taos, in the Antonio Martinez or Godol Land Grant in projected Section 24, T26N, R12E, Taos County. Wastewater is treated in a 4,000-gallon septic tank followed by two parallel trickling filters coupled with a 1000-gallon recirculation tank, prior to disposal in a leachfield. The modification is to increase the permitted discharge volume from 2,700 gallons per day to 4,500 gallons per day. Ground water below the site is at a depth of approximately 160 ft and has a total dissolved solids concentration of approximately 187 milligrams per liter.

DP-1163, NORTH POINT DAIRY, Eddie Schaap, Owner, proposes to modify and renew the discharge permit for the discharge of 180,000 gallons per day of wastewater from a dairy. The facility is located 12 miles north of Clovis in Sections 15, 21, 22, 27 and 28, T4N, R36E, Curry County. Wastewater gravity flows from the parlor barn into the first clay-lined lagoon and is then pumped over a screen solids separator and collects in the second clay-lined lagoon. Wastewater is then land applied by center-pivot sprinkler irrigation to 1250 acres of irrigated cropland. The modification consists of increasing the land application area from 375 to 1250 acres. Ground water below the site is at a depth of approximately 380 feet and has a total dissolved solids concentration of approximately 260 milligrams per liter. The renewal was previously noticed on October 26, 2002, with 375 acres of land application area.

DP-1168, GOFF DAIRY LLC, Buster Goff, Owner, proposes to renew the discharge permit for the discharge of 160,000 gallons per day of dairy wastewater from the Goff Dairy LLC. The facility is located 10 miles south from Lovington in Sections 20 and 21, T17S, R37E, Lea County. Dairy wastewater is collected in a concrete sump, pumped to three clay-lined lagoons in series, and land applied to 320 acres of irrigated cropland. Ground water most likely to be affected is at a depth of approximately 60 feet and has a total dissolved solids concentration of approximately 450 to 650 milligrams per liter.

DP-1289, RIVER RANCH RV PARK, Tanglee and Stevin Sanderson, Owners, proposes to discharge up to 9,900 gallons per day of domestic wastewater. The facility is located 5 miles from Ruidoso Downs in Section 7, T11S, R15E, Lincoln County. Up to 9,900 gallons per day of domestic wastewater from the RV Park shall be discharged from a septic tank leachfield system. Ground water most likely to be affected is at a depth of approximately 12 feet and has a total dissolved solids concentration of approximately 1410 milligrams per liter.

Any interested person may obtain further information from the Ground Water Pollution Prevention Section of the NM Environment Department, telephone (505) 827-2900, and may submit written comments to the Ground Water Pollution Prevention Section, NM Environment Department, P.O. Box 26110, Santa Fe, NM 87502. Prior to ruling on any proposed discharge permit or its modification, the NM Environment Department will allow thirty (30) days after the date of publication of this notice to receive written comments and during which a public hearing may be requested by any interested person. Requests for public hearing shall set forth the reasons why the hearing should be held. A hearing will be held if the NM Environment Department determines that there is significant public interest.

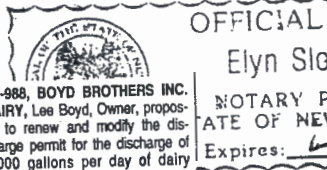

*[Signature]*  
Sworn and subscribed to before me, a Notary Public, in and for the County of Bernalillo and State of New Mexico this day of 4 August of 2003.

213.23  
at end of month.  
IBER 081020



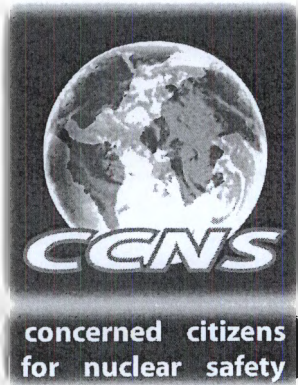

September 3, 2003

107 Cienega St.  
Santa Fe, NM 87501  
(505) 986-1973 Tel.  
(505) 986-0997 Fax  
ccns@nuclearactive.org  
www.nuclearactive.org

Maura Hanning, Program Manager  
on Prevention Section  
ment Department  
P. O. Box 26110  
Santa Fe, NM 87502-6110

Re: Los Alamos National Laboratory  
Radioactive Liquid Waste Treatment Facility DP - 1132

Dear Maura,

Concerned Citizens for Nuclear Safety (CCNS) received your August 11, 2003 letter regarding the proposed ground water discharge permit for the Los Alamos National Laboratory Radioactive Liquid Waste Treatment Facility, DP - 1132. CCNS requests that a public hearing be held on the draft discharge permit.

Should you have any comments or questions, please contact me.

Sincerely,

Joni Arends  
Executive Director



## Curt Frischkorn

---

**From:** Joni Arends [jarends@nuclearactive.org]  
**Sent:** Wednesday, September 03, 2003 6:26 PM  
**To:** Maura Hanning  
**Cc:** Curt Frischkorn (E-mail)  
**Subject:** RE: DP - 1132 - RLWTF proposed permit



RLWTF.2\_9=3=03. ATT00011.txt  
doc

September 3, 2003

Maura Hanning, Program Manager  
Ground Water Pollution Prevention Section  
New Mexico Environment Department  
P. O. Box 26110  
Santa Fe, NM 87502-6110

Re: Los Alamos National Laboratory  
Radioactive Liquid Waste Treatment Facility DP - 1132

Dear Maura,

Concerned Citizens for Nuclear Safety (CCNS) received your August 11, 2003 letter regarding the proposed ground water discharge permit for the Los Alamos National Laboratory Radioactive Liquid Waste Treatment Facility, DP - 1132. CCNS requests that a public hearing be held on the draft discharge permit.

Should you have any comments or questions, please contact me.

Sincerely,

Joni Arends  
Executive Director

At 1:23 PM -0600 9/3/03, Maura Hanning wrote:

>Hi Joni, I believe we did this particular public notice following our old  
>regulations because LANL had submitted the application prior to the  
>promulgation of the new public notice regulations. Therefore, the right to  
>a hearing is still tied to the date of publication of the public notice and  
>is not tied to the date of release of a draft permit. So if you want to  
>preserve your right to a hearing, I believe you need to request it at this  
>time. You may later withdraw your request for hearing based upon review of  
>the draft permit. So, if you really want to preserve your rights, I suggest  
>you request a hearing before the 30 day period has ended.

>

>Maura Hanning, Manager  
>Ground Water Pollution Prevention Section  
>P.O. Box 26110  
>Santa Fe, NM 87502  
>(505) 827-2945 (phone), (505) 827-2965 (fax)  
>maura\_hanning@nmenv.state.nm.us

>

>  
>-----Original Message-----  
>From: Joni Arends [mailto:jarends@nuclearactive.org]  
>Sent: Wednesday, September 03, 2003 12:58 PM  
>To: Maura\_Hanning@nmenv.state.nm.us  
>Subject: Fwd: DP - 1132 - RLWTF proposed permit  
>  
>  
>>Date: Wed, 3 Sep 2003 11:55:23 -0600  
>>To: maura\_hanning@nmenv.state.us.nm  
>>From: Joni Arends <jarends@nuclearactive.org>  
>>Subject: DP - 1132 - RLWTF proposed permit  
>>Cc:  
>>Bcc:  
>>X-Attachments: :Joni:110583:RLWTF 9/3/03:  
>>  
>>Maura,  
>>Attached please find our letter regarding the above-referenced  
>>proposed permit. Please reply that you have received it. Thank you.







SEP 09 2003

Sept. 6, 2003

Maura Hanning, Program Manager  
Ground Water Pollution Prevention Section  
New Mexico Environment Department  
P.O. Box 26110  
Santa Fe, NM 87502-6110

Re: Los Alamos National Laboratory  
Radioactive Liquid Waste Treatment Facility DP- 1132

Dear Ms. Hanning,

Tewa Women United received a copy of the letter you addressed to Pi'ee Quiyo regarding the proposed ground water discharge permit for the Los Alamos National Laboratory Radioactive Liquid Waste Treatment Facility, DP-1132. We, Tewa women living near and around the discharge area are requesting that a public hearing be held on the draft discharge permit.

Please contact us, Tewa Women United at 747-3259 should you have any comments or questions.

Sincerely,

A handwritten signature in cursive script that reads "Kathleen M. Sanchez". The signature is written in black ink and is positioned above the printed name and title.

Kathleen M. Sanchez  
Co-Director

Rt. 5 Box 298 Santa Fe, NM 87506 (505) 455-3964 Phone/ Fax

: 02168





BILL RICHARDSON  
GOVERNOR

*State of New Mexico*  
**ENVIRONMENT DEPARTMENT**

*Ground Water Quality Bureau*

*Harold Runnels Building*

*1190 St. Francis Drive, P.O. Box 26110*

*Santa Fe, New Mexico 87502-6110*

*Telephone (505) 827-2918*

*Fax (505) 827-2965*



RON CURRY  
SECRETARY

DERRITH WATCHMAN-MOORE  
DEPUTY SECRETARY

**CERTIFIED MAIL – RETURN RECEIPT REQUESTED**

August 11, 2003

Susan Diane  
P.O. Box 9855  
Santa Fe, New Mexico 87504

Dear Ms. Diane:

Enclosed is a copy of the public notice pertaining to the proposed ground water discharge permit for Los Alamos National Laboratory's Radioactive Liquid Waste Treatment Facility. The public notice is being published by the New Mexico Environment Department in the Albuquerque Journal and the Los Alamos Monitor on approximately August 8, 2003.

Any interested person may obtain further information from the Ground Water Pollution Prevention Section of the New Mexico Environment Department, telephone (505) 827-2900, and may submit written comments to the Ground Water Pollution Prevention Section, New Mexico Environment Department, P.O. Box 26110, Santa Fe, NM 87502. Prior to ruling on any proposed discharge permit or its modification, the New Mexico Environment Department will allow thirty (30) days after the date of publication of this notice to receive written comments, during which a public hearing may be requested by any interested person. Requests for public hearing shall set forth the reasons why the hearing should be held. A hearing will be held if the NM Environment Department determines that there is significant public interest.

You are being provided with a copy of this public notice because of correspondence received by you in response to the initial public notice for this facility, which was published in November, 1996. Please provide written comment if you wish to request a public hearing at this time, or contact Curt Frischkorn of the Ground Water Pollution Prevention Section at (505) 827-0078 if you have any questions.

Sincerely,

A handwritten signature in cursive script, appearing to read "Maura Hanning".

Maura Hanning, Program Manager  
Ground Water Pollution Prevention Section

## Public Notice DP-1132

Reviewer - Curt Frischkorn

**DP-1132, Los Alamos National Laboratory, Radioactive Liquid Waste Treatment Facility (RLWTF)**, Ralph Erickson, U.S. Department of Energy, Office of Los Alamos Site Operations Manager, proposes to continue the discharge of up to 41,770 gallons per day of industrial effluent from the RLWTF. The facility is located approximately 1 mile south of the Town of Los Alamos at Technical Area 50, in Section 22, T19N, R6E, Los Alamos County. Radioactive liquid waste is conveyed to the RLWTF via double encased pipe, where it is treated by the following batch treatment process: raw and pretreated wastewater is collected in influent tanks prior to clarification. Clarified supernatant is then treated with a variety of filtration processes, followed by ion exchange. Effluent is either discharged to Mortandad Canyon, or receives further treatment by reverse osmosis (RO) prior to discharge. Reject from the RO unit receives further treatment via clarification followed by Electrodialysis Reversal (EDR). EDR product is routed to the RLWTF influent tanks where it reenters the treatment process, while EDR concentrate flows to an evaporator. Evaporator distillate is either discharged to Mortandad Canyon or held for further treatment. Evaporator distillate and RO permeate with tritium concentrations exceeding 20 nCi/L are trucked to Technical Area 53 for further treatment. Solids removed from the primary clarifier and the TUF unit are concentrated and dewatered prior to disposal at Technical Area 54 (TA-54), while filtrate from the dewatering of solids is routed to the RLWTF influent tanks where it reenters the treatment process. Evaporator bottoms are stabilized by off-site treatment prior to disposal at TA-54. The depth to alluvial ground water below the outfall in Mortandad Canyon is approximately 1 foot, and has a total dissolved solids concentration of approximately 320 milligrams per liter. The depth to regional ground water below the facility is approximately 970 feet, and has a total dissolved solids concentration of approximately 165 milligrams per liter.

Ralph Erickson, Manager  
Office of Los Alamos Site Operations  
National Nuclear Security Administration  
U.S. Department of Energy  
528 35<sup>th</sup> Street  
Los Alamos, New Mexico 87544

Beverly Ramsey, Director  
Risk Reduction and Environmental Stewardship Division  
Los Alamos National Laboratory  
P.O. Box 1663, MS-J591  
Los Alamos, New Mexico 87545





*Los Alamos National Laboratory/University of California*  
 Risk Reduction & Environmental Stewardship (RRES)  
 Remediation Services (RS), MS M992  
 Los Alamos, New Mexico 87545  
 (505) 667-0808/FAX (505) 665-4747



*National Nuclear Security Administration.*  
 Los Alamos Site Operations, MS A316  
 Environmental Restoration Program  
 Los Alamos, New Mexico 87544  
 (505) 667-7203/FAX (505) 665-4504

Date: September 04, 2003  
 Refer to: ER2003-0566

Mr. John Young, Corrective Action Project Leader  
 Permits Management Program  
 NMED – Hazardous Waste Bureau  
 2905 Rodeo Park Drive East  
 Building 1  
 Santa Fe, NM 87505-6303

SEP 12 2003

**SUBJECT: STATUS OF MORTANDAD CANYON SEDIMENT INVESTIGATIONS**

Dear Mr. Young:

Enclosed is a report entitled "Status of Mortandad Canyon Sediment Investigations" (LA-UR-03-5997) which briefly summarizes sediment investigations conducted to date under the "Work Plan for Mortandad Canyon" (LA-UR-97-3291). Also, enclosed is an electronic file on CD that includes analytical data from all sediment samples collected by the Risk Reduction and Environmental Stewardship - Remediation Services Project in Mortandad Canyon and its tributaries, and maps showing sample locations. A more complete presentation and assessment of data will occur in a future Mortandad Canyon Investigation Report, which will also include data on surface water and groundwater. This submission of data and maps fulfills a request you made in a letter dated December 12, 2002, and the report satisfies a request you made later.

This report and the accompanying electronic file contain data regarding radioactive materials, the management of which is regulated under the Atomic Energy Act and specifically excluded from regulation under the Resource Conservation and Recovery Act and the New Mexico Hazardous Waste Act. These data are provided to the New Mexico Environment Department for information purposes only.

Please contact Steven Reneau at (505) 665-3151 if you have any questions.

Sincerely,

David McInroy, Deputy Project Director  
 Remediation Services  
 Los Alamos National Laboratory

Sincerely,

David Gregory, Project Manager  
 Department of Energy  
 Los Alamos Site Operations



An Equal Opportunity Employer/Operated by the University of California

Printed on Recycled Paper

: 02173

Mr. John Young  
ER2003-0566

-3-

September 4, 2003

DM/DG/SR/KR/dv

SEP 12 2003

Enclosures: Status of Mortandad Canyon Sediment Investigations (LA-UR-03-5997)  
CD with Electronic Data (To Mr. John Young)  
GISLab Map M200739, M200747, M200741, M200737, M200760 (To Mr. John Young)

Cy:(w/enc)

N. Quintana, RRES-RS, MS M992  
D. Gregory, LASO, MS A316  
J. Kieling, NMED-HWB  
V. Maranville, NMED-HWB  
J. Schoeppner, NMED-GWQB  
S. Yanicak, NMED-OB  
L. King, EPA Region 6  
RRES-RS File, MS M992  
IM-5, MS A150  
RPF MS M707

Cy:(w/o enclosure)

D. McInroy, RRES-RS, MS M992  
B. Ramsey, RRES-DO, MS J591  
S. Reneau, MS D462  
K. Rich, RRES-RS, MS M992  
S. Martin, NMED-HWB  
C. Voorhees, NMED-OB



SEP 12 2003

## STATUS OF MORTANDAD CANYON SEDIMENT INVESTIGATIONS

Steven Reneau, Randy Ryti, Paul Drakos, and Terre Mercier

August 26, 2003

Los Alamos National Laboratory Report LA-UR-03-5997

### INTRODUCTION

Investigations of potentially contaminated sediment deposits in Mortandad Canyon and its tributary canyons by the Los Alamos National Laboratory (LANL) Environmental Restoration (ER) Project (now the Risk Reduction and Environmental Stewardship-Remediation Services Project) Canyons team have been in progress since 1998. This work has been conducted following the "Work Plan for Mortandad Canyon" (the "work plan") (LANL 1997, 56835; LANL 1999, 62777), which was approved by the New Mexico Environment Department (NMED) in December 2002 (NMED 2002, 73830). Included in this work plan are investigations of potential contamination in sediment, surface water, and groundwater in Mortandad Canyon proper, as well as in Effluent Canyon, Ten Site Canyon, and an unnamed tributary canyon that heads in Technical Area (TA) 5 (hereafter referred to collectively as the "Mortandad Canyon reaches"). A short tributary to Ten Site Canyon, "Pratt Canyon", has been investigated separately as part of characterization activities at TA-35. This report summarizes analytical results from all sediment samples collected by the Canyons team to date in implementation of the work plan, as well as results from relevant sediment samples from the Mortandad Canyon reaches and from Pratt Canyon that were collected by other ER Project investigations in TA-5, TA-35, and TA-50. An accompanying electronic data file includes all analytical results from these samples.

This report and the electronic file contain data regarding radioactive materials, the management of which is regulated by the Department of Energy under the Atomic Energy Act. The radioactive materials are specifically excluded from regulation under the Resource Conservation Recovery Act and the Hazardous Waste Act. These data are provided to the NMED for informational purposes only.

### FIELD INVESTIGATIONS

Field investigations that include detailed geomorphic mapping, associated geomorphic characterization, and sediment sampling have been conducted in all reaches specified in the work

plan except reach M-7. In some of these reaches, two rounds of sampling have been conducted. Table 1 presents a summary of sediment sampling in Mortandad Canyon and tributary canyons, including the years in which samples were collected in each reach or subreach, and the number of samples collected for each analytical suite. The term "subreach" is used for subdivisions or additions to the reaches discussed in the work plan; these subdivisions were made to facilitate more detailed evaluation of possible contributions from different potential release sites (PRSs) in the watershed. Table 1 includes samples collected by the Canyons team and also as part of other ER Project investigations. Sample locations are shown on the geomorphic maps listed in Table 2. Table 2 also includes a watershed map that shows the locations of all reaches.

Reach M-7 has not been investigated because it is a contingency reach only planned for investigation if results from upstream reaches indicated transport of contaminated sediments at least as far as reach M-6 or down Cañada del Buey into lower Mortandad Canyon (LANL 1997, 56835, p. 7-26). Results from reach CDB-4 in Cañada del Buey, immediately upstream from the LANL boundary (Drakos et al. 2000, 68739), and from reach M-6 (discussed below), do not indicate the presence of analytes at levels above background, and therefore no investigation is planned for reach M-7.

As part of the geomorphic characterization, field gross gamma radiation data were obtained from walkover surveys and from fixed-point measurements in a series of vertical profiles in selected reaches. Gamma radiation was targeted because cesium-137 (Cs-137) is a primary contaminant released from the TA-50 Radioactive Liquid Waste Treatment Facility (RLWTF) outfall and is a high-energy gamma emitter that is easily detected with field instruments. In addition, Cs-137 is expected to be collocated with other particle-bound contaminants released from the RLWTF. Walkover surveys were conducted in the entirety of reaches M-3 and M-4, and in parts of M-5 and TS-3, in 1999 and 2000. Other areas were not surveyed with this method either because concentrations of Cs-137 are too low to make screening data useful, or because the reaches are too brushy and/or rocky to allow efficient application of walkover surveys (e.g., E-1 and M-2). Characterization in reaches E-1, M-2, M-3, and M-4 included fixed-point measurements because Cs-137 concentrations in these reaches are high enough to make this a useful field technique. Some fixed-point beta-gamma radiation measurements were also made in reach TS-2 because these data had proved useful upstream in Pratt Canyon, but Sr-90 levels in TS-2 were found to be too low to make field radiation surveys useful there.

**Table 1**  
**Summary of ER Project Sediment Sampling In Mortandad Canyon**

Reach or Subreach	Reach Length (km)*	Source	Year of Sediment Sampling	Number of Samples Collected															
				Gamma Spec	H-3	Iso Pu	Iso Th	Iso U	Am-241	Sr-90	Metals	CN	Anions	Perchlorate	HE	PCBs	Pest	SVOCs	VOCs
E-1 East	0.30	Canyons	1998, 2001	40	15	40	10	15	5	40	40	5	10	10		15	15	15	10
		Other	1993	42	42	42		42		21	42					16		40	24
E-1 West		Canyons	1998, 2001	11	11	11	6	11	5	11	11	5	6	6		11	11	11	
M-1 East	0.26	Canyons	1998	6	6	6		6	6	6	6	6				6	6	5	
M-1 West		Canyons	1998	6	6	6		6	6	6	6	6				6	6	6	
M-2 East	1.01	Canyons	2001	42	10	42	10	10		42	42		10	10		10	10	10	7
M-2 West		Canyons	1998, 2001	63	20	63	10	20	10	63	63	10	10	10		20	20	20	9
		Other	1993	12	12	12		12		8	12					2		12	12
M-3	0.90	Canyons	1999, 2001	82	15	82	10	15		82	82		10	10		15	15	15	10
M-4	0.66	Canyons	1999, 2001	81	15	81	10	15		81	81			10		15	15	15	10
		Other	1995	1	1	21		21			21							21	21
M-5	0.56	Canyons	2000, 2001	13	14	13	14	13	7	14	13	7				13	13	13	
M-6	0.20	Canyons	2002	10		10		10		10	10	10						10	
MCW-1	0.24	Canyons	2002			8	8	8			8	8			8			8	
MCW-2 East	0.50	Canyons	2002			7	7	7			7	7			7			7	
MCW-2 North		Canyons	2002			9	9	9			9	9			9			9	
MCW-2 West		Canyons	2002			9	9	9			9	9			9			9	

Table 1 (continued)

Reach or Subreach	Reach Length (km)*	Source	Year of Sediment Sampling	Number of Samples Collected															
				Gamma Spec	H-3	Iso Pu	Iso Th	Iso U	Am-241	Sr-90	Metals	CN	Anions	Perchlorate	HE	PCBs	Pest	SVOCs	VOCs
Pratt Canyon	0.18	Other	1994, 1997, 1998	12	12	33		33	9	11	14	9	2			12	10	12	
TS-1 Central	0.59	Canyons	1999	4	4	4		4		4	4					4	4	4	
		Other	1993	59	59	59		59	1		59					1		59	59
TS-1 East		Canyons	1999	4	4	4		4		4	4					4	4	4	
TS-1 West		Other	1993	66	66	66		66	40		66					34		66	66
TS-2 Central	0.51	Canyons	1999	4	4	4		4		4	4					4	4	4	
		Other	1995			1		1											
TS-2 East		Canyons	1999	4	4	4		4		4	4					4	4	4	
		Other	1995			6		6											
TS-2 West		Canyons	1999	4	4	4		4		4	4					4	4	4	
TS-3		0.30	Canyons	2001	10	10	10	10	10		10	10					10	10	10

Note: Blank cells indicate no sample results for that analyte suite in that reach.

\* Length refers to area mapped and characterized, and may include multiple subreaches.

**Table 2**  
**Mortandad Canyon Geomorphic Maps**

Reach	GISLab Map #
Watershed map, showing locations of all reaches	m200739
M-1, E-1	m200747
M-2, TS-1, TS-2, Pratt Cyn	m200741
M-3, M-4, TS-3, MCW-1	m200737
M-5, M-6, MCW-2	m200760

### MODIFICATIONS TO WORK PLAN

During implementation of this work, several modifications have been made to the analytical suites and the investigation approach presented in the work plan. These modifications were in part discussed with NMED during preparatory stages for individual sampling events, and have in part been incorporated into subsequent work plans submitted to the NMED for other canyons as the Canyons investigation approach has evolved. Although not specified in the work plan, analytical data have been obtained in select reaches for high explosives (HE), isotopic thorium, perchlorate and other anions, and volatile organic compounds (VOCs) because these were judged to be potential data gaps based on process knowledge and/or previous data. In 1998 a reach "M-1 West" was added and investigated upstream of reach M-1 as shown in the work plan. M-1 West is located at the head of the canyon just east of Diamond Drive, and was investigated to better determine contaminant levels that would be associated with releases from TA-3. In 2001, a reach "M-2 East" was investigated downstream of reach M-2 as shown in the work plan. M-2 East is located downstream of the easternmost PRS at TA-35, and was investigated to better determine if TA-35 PRSs have had a measurable impact on sediments in Mortandad Canyon. Investigation of M-2 East was partially in support of planned ER Project work at TA-35 under the "Sampling and Analysis Plan for the Middle Mortandad/Ten Site Aggregate" (LANL 2002, 73092). Other objectives of the M-2 East investigation were to obtain additional data on contaminants released from TA-50, and to reduce the length of the non-sampled area between Effluent Canyon and reach M-3. An additional modification is that several reaches are shorter than the estimated minimum reach length of 0.5 km presented in the work plan (E-1, M-1, M-6, MCW-1, TS-3). Most of these reaches are shorter than 0.5 km because contaminants were expected to be present at low levels or to be absent (M-1, M-6, MCW-1, TS-3), and it was judged that shorter reaches would be adequate to obtain sufficient characterization data in the first phase of sampling. The exception, E-1, includes the entirety of the canyon between the TA-50 RLWTF outfall and Mortandad Canyon (0.2 km), and a short part of the upstream canyon with lower contaminant levels.

## NATURE AND SOURCES OF CONTAMINANTS

Inorganic, organic, and radionuclide analytes have been identified as chemicals of potential concern (COPCs) in the Mortandad Canyon reaches based on detected or non-detected analytical results that exceed sediment background values (BVs) for inorganic chemicals, or based on detected results for radionuclides and organic chemicals. The sediment BVs are presented in Rytí et al. (1998, 59730) and McDonald et al. (2003, 76084). Tables 3 through 5 present maximum concentrations in each reach for all COPCs in Mortandad Canyon sediment samples. Maximum concentrations are shown for the purpose of identifying COPCs and indicating general spatial trends in concentrations. For purposes of assessing risk, more representative concentrations can be used.

Table 3 presents the maximum values for either detected or non-detected inorganic analytes, and Tables 4 and 5 present maximum detected sample results for organic and radionuclide analytes, respectively. Highlighted values in these tables are concentrations or detection limits greater than BVs for inorganic and radionuclide analytes that have BVs, or detected values for analytes without BVs. These highlighted values indicate analytes that are considered a COPC in that reach. Separate columns are included for sample locations that have been removed either in an interim action (LANL 1997, 55834) or during maintenance of the sediment traps (WGII 2000, 70735). No HE analytes are shown in these tables because none were detected. Several organic analytes were eliminated as COPCs because they were not detected or were detected in less than 5% of the sample results in a sub-watershed; elimination of organic analytes that were detected less than 5% of the time follows the screening processes developed for Los Alamos and Pueblo Canyons in discussions with the NMED (Katzman 2002, 73667), and is also consistent with risk assessment guidance from the Environmental Protection Agency (EPA 1989, 08021) and NMED (NMED 2000, 70107). As used in this assessment, sub-watersheds consist of (1) upper reaches of Mortandad Canyon (M-1 through M-4) and Effluent Canyon (E-1); (2) lower Mortandad Canyon (M-5 and M-6); (3) Ten Site Canyon (TS-1 through TS-3) and Pratt Canyon; and (4) the unnamed tributary canyon that heads in TA-5 (MCW-1 and MCW-2). Some analytes (e.g., antimony) are identified as COPCs based on detection limits exceeding BVs in some samples. Other analytes retained as COPCs (e.g., Th-230) have only a single sample result reported to be greater than the BV.

**Table 3**  
**Maximum Values for Inorganic COPCs in Mortandad Canyon Sediment Samples**

Analyte Name	Background Value	M-1 West	M-1 East	E-1 West	E-1 East	M-2 West	M-2 East	M-3	M-4	M-4 (Removed)	M-5	M-6	MCW-1
Aluminum	15400	7800	26000	19000	11000	8200	5100	10300	9910	8620	6300	12420	13880
Antimony	0.83	[11]		[0.56]	0.69	[13]	0.51	0.8	[1.9]	[0.64]	0.69		
Arsenic	3.98	4.4	8.4	11	6.1	4.3	2.8	4	4.6	3.8	3	2.7	3.22
Barium	127	89	270	350	160	130	85	115	146	104	110	125	125
Beryllium	1.31	[0.93]	1.4	2.4	1	0.95	0.74	1	1.1	[1.2]	0.94	1.05	0.949
Boron	4.1	[46]	[40]	[60]	[39]	[35]							
Bromide	n/a			8.31	12.4	3.83	1.12	0.944					
Cadmium	0.4	[0.93]	[0.79]	[1.2]	2.2	0.8	0.074	0.25	0.19	[0.05]	0.14	[0.51]	[0.582]
Calcium	4420	2500	3600	5800	51000	22000	12000	5460	5180	3000	2700	2800	2490
Chloride	17.1			185	45.2	39.2	52.7	35.8					
Chromium	10.5	8.2	18	50	140	22	14	17.5	11.1	11.9	5.4	8.14	8.96
Cobalt	4.73	3.9	7.7	12	6	4.5	3.8	3.9	5.1	4.4	4.1	3.77	3.99
Copper	11.2	6	14	20	120	47	35	29	37.2	16.9	6.9	8.22	7.26
Cyanide (Total)	0.82	[0.93]	[0.79]	[1.2]	[0.78]	[0.7]					[0.53]	0.239	0.436
Fluoride	n/a			1.93	3.9	70.6	13.3	3.62					
Iron	13800	12000	21000	25000	13000	14000	10000	13900	14500	14700	11000	11690	12090
Lead	19.7	23	30	30	70	58	17	19.7	22.6	18.7	16	18.8	21.4
Lithium	n/a												
Magnesium	2370	1200	3400	2700	2200	1400	1100	1860	1870	1490	1300	2030	1990

Table 3 (continued)

Analyte Name	Background Value	M-1 West	M-1 East	E-1 West	E-1 East	M-2 West	M-2 East	M-3	M-4	M-4 (Removed)	M-5	M-6	MCW-1
Manganese	543	470	1300	2500	1700	530	390	429	470	481	430	385	378
Mercury	0.1	[0.19]	[0.16]	[0.24]	2.7	0.69	1.1	0.43	0.32	0.1	0.024	0.0126	0.0227
Nickel	9.38	5.3	11	11	48	8.7	6.9	7.4	8.3	6.9	5.7	6.54	6.89
Oxalate	n/a			46.5	25.8	19.3	15.8	12.8					
Perchlorate	n/a			[0.656]	[3.2]	0.959	[0.162]	0.162	[0.627]				
Selenium	0.3	[1.9]	[1.6]	[2.4]	[1.6]	[1.4]	0.59	0.73	0.78	0.81	0.56	[0.603]	[0.582]
Silicon	n/a												
Silver	1	[3.7]	[3.2]	[4.8]	8	[2.8]	2.7	0.34	7	0.29	[0.063]	0.0848	0.0929
Sodium	1470	140	190	450	1300	1700	410	599	193	114	85	134	759
Strontium	n/a												
Sulfate	58.2			232	204	181	99.9	96.2					
Thallium	0.73	[0.46]	[0.4]	[0.6]	1.6	0.8	[0.31]	0.72	[0.51]	[0.52]	[0.39]	0.201	0.23
Vanadium	19.7	16	37	30	16	16	12	15.2	16.5	31.1	14	16	18.2
Zinc	60.2	80	77	110	78	100	59	88.8	71.1	60.3	44	48.5	34.9



Table 3 (continued)

Analyte Name	Category	Background Value	MCW-2 North	MCW-2 West	MCW-2 East	TS-1 West	TS-1 West (Removed)	TS-1 Central	TS-1 East	Pratt Canyon	TS-2 West	TS-2 Central	TS-2 East	TS-3
Aluminum	All Results	15400	9470	10760	13300			10500	7320	5860	7270	7810	6960	7200
Antimony	All Results	0.83				[11.2]	[1.2]	[11.2]	0.54	[4.5]	0.73	0.68	0.67	0.4
Arsenic	All Results	3.98	2.49	3.64	3.28	4.7	3.9	3.9	3	[3.7]	3.2	3.5	3.3	3.2
Barium	All Results	127	80.9	93.7	113	160	230	132	94.5	80.5	86.8	90.2	103	120
Beryllium	All Results	1.31	0.696	0.667	0.821	2.8	2.7	1.2	0.72	0.86	0.79	0.9	0.76	0.92
Boron	All Results	4.1								[2.4]				
Bromide	All Results	n/a								[0.33]				
Cadmium	All Results	0.4	[0.532]	[0.5]	[0.53]	[1.2]	1.1	1.7	[0.02]	2.1	[0.01]	[0.02]	0.22	0.14
Calcium	All Results	4420	2290	3440	3820			2380	1850	1760	1680	1930	3070	2500
Chloride	All Results	17.1								8.5				
Chromium	All Results	10.5	6.34	7.24	8.59	10	20	9.3	6.8	6.8	6.3	7.4	9.8	9.1
Cobalt	All Results	4.73	2.74	3.09	3.39			5.9	4	3	3.6	4	5.5	4.5
Copper	All Results	11.2	9.03	11.5	8.92			12.9	119	13.2	7.5	15.4	27.2	19
Cyanide (Total)	All Results	0.82	0.359	1.37	[0.319]					[0.7]				
Fluoride	All Results	n/a								6.6				
Iron	All Results	13800	8900	10670	11370			28800	11900	8740	12500	13800	13900	13000
Lead	All Results	19.7	12.3	14.6	18	23.6	44	39.1	16.6	16.1	13	15.8	17	20
Lithium	All Results	n/a								4.3				
Magnesium	All Results	2370	1350	1680	2010			1760	1280	1140	1300	1370	1410	1400

Table 3 (continued)

Analyte Name	Category	Background Value	MCW-2 North	MCW-2 West	MCW-2 East	TS-1 West	TS-1 West (Removed)	TS-1 Central	TS-1 East	Pratt Canyon	TS-2 West	TS-2 Central	TS-2 East	TS-3
Manganese	All Results	543	342	417	375			414	322	344	396	377	373	570
Mercury	All Results	0.1	0.0207	0.044	0.0412	0.1	2	[0.1]	0.05	1.6	0.06	0.07	0.37	0.19
Nickel	All Results	9.38	4.09	4.6	5.65	9.9	3	58.9	5.4	11.5	5.8	6.1	7.5	8.1
Oxalate	All Results	n/a												
Perchlorate	All Results	n/a												
Selenium	All Results	0.3	[0.55]	[0.55]	[0.52]	[0.6]	[0.2]	[3]	1.6	[7.1]	0.77	1.1	0.75	0.62
Silicon	All Results	n/a								57.1				
Silver	All Results	1	0.09	[0.2]	0.097	3.5	33	[1.4]	[0.03]	[0.8]	[0.04]	1.3	6	4.4
Sodium	All Results	1470	95.5	97.6	119			157	93.1	[395]	121	101	372	100
Strontium	All Results	n/a								7.9				
Sulfate	All Results	58.2								24.2				
Thallium	All Results	0.73	0.159	0.219	0.128	[1.2]	2.3	[1]	[0.27]	[25.2]	[0.54]	[0.24]	[0.24]	[0.22]
Vanadium	All Results	19.7	11.5	14.2	16.3			25.9	15.2	11.9	14.9	15.7	21	17
Zinc	All Results	60.2	37	56.4	43.5			94	58.3	54.9	46.4	61	65.8	63

Notes: 1. Blackened cells indicate maximum result is above BV in that reach.

2. Blank cells indicate no sample results for that analyte in that reach.

3. [ ] indicate a non-detected sample result.

4. n/a = background value is not available.

5. Units are mg/kg.

**Table 4**  
**Maximum Values for Organic COPCs in Mortandad Canyon Sediment Samples**

Analyte Name	M-1 West	M-1 East	E-1 West	E-1 East	M-2 West	M-2 East	M-3	M-4	M-4 (Removed)	M-5	M-6	MCW-1
Acenaphthene	ND	ND	ND	ND	ND	0.088	ND	0.29	ND	1.8	ND	ND
Acetone				0.1	0.034	0.085	0.046	0.069	0.016			
Aroclor-1260	0.053	ND	0.18	0.1	0.21	0.054	0.39	0.12	0.07	ND		
Aroclors (Mixed)				0.053	ND							
Benzo(a)anthracene	ND	ND	ND	ND	0.12	0.22	ND	0.58	ND	ND	ND	ND
Benzo(a)pyrene	ND	ND	ND	ND	0.11	0.16	ND	0.59	ND	ND	ND	ND
Benzo(b)fluoranthene	ND	ND	ND	0.1	0.12	0.11	ND	0.6	ND	ND	ND	ND
Benzo(k)fluoranthene	ND	ND	ND	ND	0.13	0.069	ND	0.2	ND	ND	ND	ND
Bis(2-ethylhexyl)phthalate	ND	ND	ND	0.16	0.4	0.091	ND	0.41	ND	ND	0.207	0.191
Chlorophenol[2-]	ND	ND	ND	ND	ND	ND	ND	ND	ND	ND	ND	ND
Chrysene	ND	ND	ND	ND	0.16	0.21	ND	0.59	ND	ND	ND	ND
DDT[4,4'-]	ND	ND	0.0096	0.078	0.035	0.013	0.028	0.015	ND	ND		
Dichloroethene[cis-1,2-]				ND	ND			0.002	0.003			
Di-n-butylphthalate	ND	ND	ND	ND	ND	ND	ND	ND	ND	ND	ND	ND
Fluoranthene	ND	ND	0.17	0.21	0.26	0.59	0.15	1.5	ND	ND	ND	ND
Fluorene	ND	ND	ND	ND	ND	0.089	ND	0.24	ND	ND	ND	ND
Isopropyltoluene[4-]				0.044	0.032	ND	0.026	ND	ND			
Phenanthrene	ND	ND	ND	0.12	0.23	0.56	0.11	1.5	ND	ND	ND	ND

Table 4 (continued)

Analyte Name	M-1 West	M-1 East	E-1 West	E-1 East	M-2 West	M-2 East	M-3	M-4	M-4 (Removed)	M-5	M-6	MCW-1
Pyrene	ND	ND	ND	ND	0.26	0.55	ND	1.4	0.42	ND	ND	ND
Tetrachloroethene				ND	ND	ND	ND	0.005	0.008			
Toluene				0.043	0.011	0.087	0.023	0.016	0.027			
Trichlorofluoromethane				0.019	0.022	0.0027	ND	0.0037	ND			
Trimethylbenzene[1,2,4-]				0.026	ND	ND	0.068	0.003	0.004			
Xylene[1,2-]								0.002	0.001			
Xylene[1,3-]								0.005	0.004			

Table 4 (continued)

Analyte Name	MCW-2 North	MCW-2 West	MCW-2 East	TS-1 West	TS-1 West (Removed)	TS-1 Central	TS-1 East	Pratt Canyon	TS-2 West	TS-2 Central	TS-2 East	TS-3
Acenaphthene	0.0108	ND	ND	ND	ND	0.51	ND	6.4	ND	ND	ND	ND
Acetone				0.056	ND	0.041						
Aroclor-1260				1.52	ND	0.63	0.13	0.6	0.058	0.086	0.11	0.076
Aroclors (Mixed)				1.52	6	ND		ND				
Benzo(a)anthracene	ND	ND	ND	0.91	ND	1.1	0.44	8.2	ND	ND	ND	0.059
Benzo(a)pyrene	ND	ND	ND	1.1	ND	1.2	0.85	7.3	ND	ND	ND	0.084
Benzo(b)fluoranthene	ND	ND	ND	1.5	ND	1.1	1.6	7.3	ND	ND	ND	0.09
Benzo(k)fluoranthene	ND	ND	ND	0.64	ND	1.13	0.25	3.1	ND	ND	ND	0.079
Bis(2-ethylhexyl)phthalate	0.17	0.0445	ND	1.1	0.56	ND	ND	ND	ND	ND	ND	0.094
Chlorophenol[2-]	0.024	ND	ND	ND	ND	ND	ND	ND	ND	ND	ND	ND
Chrysene	ND	ND	ND	1.1	ND	1.4	0.91	7.6	ND	ND	ND	0.087
DDT[4,4'-]						ND	ND	ND	ND	ND	ND	0.0095
Dichloroethene[cis-1,2-]				ND	ND	ND						
Di-n-butylphthalate	0.0406	ND	ND	2.6	ND	3	ND	ND	ND	ND	ND	ND
Fluoranthene	ND	ND	ND	1.9	ND	2.4	1.7	24	0.46	0.36	ND	0.35
Fluorene	0.0195	ND	ND	ND	ND	0.47	ND	4.8	ND	ND	ND	ND
Isopropyltoluene[4-]				0.035	ND	ND						
Phenanthrene	ND	ND	ND	1	ND	3.1	0.81	30	ND	ND	ND	ND
Pyrene	ND	ND	ND	2	ND	2.4	2.2	22	0.5	0.66	ND	0.38

Table 4 (continued)

Analyte Name	MCW-2 North	MCW-2 West	MCW-2 East	TS-1 West	TS-1 West (Removed)	TS-1 Central	TS-1 East	Pratt Canyon	TS-2 West	TS-2 Central	TS-2 East	TS-3
Tetrachloroethene				ND	ND	ND						
Toluene				0.022	ND	ND						
Trichlorofluoromethane				ND	ND	ND						
Trimethylbenzene[1,2,4-]				ND	ND	ND						
Xylene[1,2-]												
Xylene[1,3-]												

- Notes: 1. Blackened cells indicate detected results in that reach.  
 2. Blank cells indicate no sample results for that analyte in that reach.  
 3. ND = analyte is not detected.  
 4. Units are mg/kg.

**Table 5**  
**Maximum Values for Radionuclide COPCs In Mortandad Canyon Sediment Samples**

Analyte Name	Background Value	M-1 West	M-1 East	E-1 West	E-1 East	M-2 West	M-2 East	M-3	M-4	M-4 (Removed)	M-5	M-6	MCW-1
Americium-241 <sup>a</sup>	0.04	ND	ND	0.157	642	524	211	223	112	20.7	ND	ND	
Cesium-134	n/a	ND	ND	ND	0.196	0.24	0.114	ND	ND	ND	ND	ND	
Cesium-137	0.9	ND	0.64	2.14	2530	870	557	298	276	43.5	0.93	0.409	
Cobalt-60	n/a	ND	ND	ND	5.22	2.45	0.5	1.47	0.445	ND	ND	ND	
Plutonium-238	0.006	0.04	0.048	0.417	88.7	203	113	40.9	32.2	8.41	ND	ND	ND
Plutonium-239	0.068	ND	0.042	30.1	1360	596	157	123	64.5	25.6	0.095	ND	ND
Sodium-22	n/a	ND	ND	ND	0.49	0.151	ND	ND	ND	ND	ND	ND	
Strontium-90	1.04	ND	ND	ND	273	35.9	20	8.6	9.64	3.5	0.4	0.304	
Thorium-230	2.29			1.15	0.93	1.2	1.34	1.22	1.24		1.46		2.44
Tritium	0.093	0.13	ND	ND	105	7.15	0.518	0.321	0.278	ND	0.055		
Uranium-234	2.59	0.649	1.306	2.41	16.04	14.7	1.57	1.83	1.6	1.43	1.52	1.25	2.13
Uranium-235 <sup>b</sup>	0.2	0.041	0.118	0.112	0.683	0.8	0.18	0.242	0.103	0.14	0.174	0.103	0.105
Uranium-238	2.29	0.678	1.44	2.65	7.125	10.7	1.81	1.64	1.52	1.44	1.62	1.21	2.04

Table 5 (continued)

Analyte Name	Background Value	MCW-2 North	MCW-2 West	MCW-2 East	TS-1 West	TS-1 West (Removed)	TS-1 Central	TS-1 East	Pratt Canyon	TS-2 West	TS-2 Central	TS-2 East	TS-3
Americium-241 <sup>a</sup>	0.04				1.82	170.9	2.3	ND	0.412	ND	ND	ND	ND
Cesium-134	n/a				ND	ND	ND	ND	ND	ND	ND	ND	ND
Cesium-137	0.9				3.59	72.83	3.19	0.65	25	0.48	0.45	0.87	1.22
Cobalt-60	n/a				1.30	0.91	ND	ND	0.368	ND	ND	ND	ND
Plutonium-238	0.006	0.0229	ND	ND	67.8	5190	16.8	3.63	0.02	1.52	2.209	1.351	1.55
Plutonium-239	0.068	0.026	0.038	0.0445	19.5	453	13.8	1.033	1.73	0.596	0.894	0.703	0.77
Sodium-22	n/a				ND	ND	ND	ND	ND	ND	ND	ND	ND
Strontium-90	1.04						ND	ND	118	6.7	2.54	8.3	3.1
Thorium-230	2.29	1.28	1.84	1.5									1.43
Tritium	0.093				1.50	19.1	0.303	ND	0.211	0.143	0.134	0.088	0.297
Uranium-234	2.59	1.16	1.28	1.21	2.735	5.295	2.469	1.262	2.1816	1.136	1.132	2.25	1.84
Uranium-235 <sup>b</sup>	0.2	0.108	0.0743	0.078	ND	ND	0.255	0.071	0.102	0.087	0.075	0.1	0.098
Uranium-238	2.29	1.1	1.33	1.33	3.049	2.67	3.006	1.333	1.899	1.193	1.121	2.37	1.75

- Notes: 1. Blackened cells indicate maximum result is above BV in that reach.  
 2. Blank cells indicate no sample results for that analyte in that reach.  
 3. ND = analyte is not detected.  
 4. n/a = background value is not available.  
 5. Units are pCi/g.

<sup>a</sup> Maximum from either alpha or gamma spectroscopy

<sup>b</sup> Maximum from alpha spectroscopy



Inorganic COPCs apparently have a variety of sources in the watershed, including the upstream parts of Mortandad Canyon (TA-3 and TA-48), Effluent Canyon upstream and downstream of the TA-50 RLWTF outfall, the upper part of Ten Site Canyon (TA-35 and/or TA-50), and Pratt Canyon. Table 3 shows that maximum concentrations for different inorganic COPCs are found in a variety of reaches, supporting the interpretation that there are a variety of sources.

Organic COPCs also apparently have a variety of sources in the watershed. Maximum results for polychlorinated biphenyls (PCBs) and polycyclic aromatic hydrocarbons (PAHs) occur in Ten Site Canyon and Pratt Canyon (Table 4), indicating sources at TA-35 and/or TA-50. Among the organic chemicals detected in more than 5% of the sample results and retained as COPCs were acetone, toluene, and bis(2-ethylhexyl)phthalate, which are all considered to be common analytical laboratory contaminants by the EPA. These organic chemicals could therefore be due to field or analytical laboratory contamination and may not primarily represent releases from LANL PRSs.

The most important source for radionuclide COPCs in the Mortandad Canyon watershed is the TA-50 RLWTF outfall (located in Effluent Canyon), and maximum concentrations for most radionuclide COPCs occur in reach E-1 East or downstream in reach M-2 (Table 5). Secondary sources include discharges from TA-35 into Pratt Canyon and from TA-50 into the head of Ten Site Canyon.

## EXTENT OF CONTAMINANTS

In each reach, the potential lateral extent of contaminants distributed by floods is the extent of the "c" (post-1942 channel) and "f" (post-1942 floodplain) units on the geomorphic maps. The area occupied by these geomorphic units varies from 1 to 90 m in width, being least in parts of steep rocky reaches such as E-1 East and TS-2 East, and greatest in reaches M-3 and M-4. The estimated vertical extent of contaminants contained within post-1942 sediment deposits ranges from less than 5 cm to at least 1.5 m deep, representing the thickness of sediment deposited by floods since initial releases. Contaminants are expected to extend deeper into older sediments in some areas associated with the infiltration of effluent and storm water and with alluvial groundwater flow. However, the extent of subsurface contaminants is less well known than the lateral extent of contaminants that have been dispersed by floods. Collection of additional data to address the subsurface extent of contaminants is planned as part of the Mortandad Canyon groundwater work plan addendum (in preparation).

Available data suggest that the downstream extent of contaminants in Mortandad Canyon that were released from LANL sites and carried by floods may be somewhere between reaches M-4 and M-5, although there is some uncertainty here (as discussed below). From the perspective of potential human health exposure pathways, the most significant contaminant released into the

watershed prior to the first discharges from the TA-50 RLWTF in 1963 is strontium-90 (Sr-90), released from TA-35 into Pratt Canyon. Sr-90 has been detected at levels above the sediment BV (1.04 pCi/g) in M-4 and in upstream reaches, but not in M-5 or M-6. From a human health perspective, the most significant contaminant released from the TA-50 RLWTF that is associated with sediment is Cs-137. In sampling by the Canyons team, Cs-137 has also been detected in multiple samples at levels above the sediment BV (0.9 pCi/g) in M-4 and in upstream reaches, but only slightly higher than the BV in one sample in M-5 (0.93 pCi/g) and in no samples in M-6. In contrast, the Environmental Surveillance Program (ESP) reported Cs-137 above the BV in M-5 in 1997 and 2001 (2.58 and 3.16 pCi/g at station A-6; ESP 1998, 59904, p. 168; ESP 2002, 73806, p. 303), although below the BV in other years. We plan to resample station A-6 to see if these results can be confirmed and to help constrain the downstream extent of contamination.

Additional analytes have been detected at levels above BVs in either M-5 or M-6, but the spatial distributions of most of these do not indicate significant releases from any LANL PRS (e.g., no pattern of decreasing concentrations downstream, as seen for Cs-137, Sr-90, and other contaminants). Exceptions are plutonium-238 (Pu-238) and plutonium-239,240 (Pu-239,240), which are detected at low levels above BVs in M-5 but not in M-6, suggesting that for these analytes the downstream extent of flood-borne contaminants may be between M-5 and M-6. However, understanding the source of plutonium isotopes is complicated by the inference from regional soil data that plutonium may also be dispersed at levels above BVs by local stack emissions and/or by fugitive dust (Fresquez et al. 1998, 76063), and the results in M-5 may or may not record past flood transport.

Only three analytes have been retained as COPCs in reach M-6, and none of these can be clearly traced to LANL sources. These include two inorganic analytes, cadmium and selenium, which are retained only because detection limits for some samples exceed the BV. The third COPC, bis(2-ethylhexyl)phthalate, is considered by the EPA to be a common analytical laboratory contaminant, as discussed above, and the detected value in M-6 is not considered to represent releases from LANL.

## **TRANSPORT OF CONTAMINANTS**

The analytical data have been combined with geomorphic characterization data to develop preliminary contaminant inventories in the different reaches for key radionuclides, and to develop preliminary trends in contaminant concentrations in sediment deposits as a function of time of deposition. This information on contaminant inventories and concentrations is being used to refine the conceptual model of contaminant transport in the Mortandad Canyon watershed.

Figure 1 shows the preliminary estimate of the Cs-137 inventory between the TA-50 RLWTF outfall and reach M-6. Figure 1a shows the inventory by reach, normalized to units of mCi/km, and Figure 1b shows cumulative inventory, in units of mCi, that extrapolates between sampled reaches. Of the 1.5 Ci of Cs-137 estimated to be present in Effluent and Mortandad Canyons, about 50% is within the eastern 0.6 km of reach M-3. This is the area where Mortandad Canyon widens abruptly and floodwaters have historically spread across the valley bottom, causing sediments and associated contaminants to be deposited. This deposition is upstream from the sediment traps, supporting the interpretation that this part of Mortandad Canyon was a natural deposition area before construction of the sediment traps. These data revise the initial conceptual model in the work plan (LANL 1997, 56835; p. 7-21) that reach M-4 may contain the highest inventory of contaminants in the watershed.

The age of specific sediment deposits in reach M-4 with the highest concentrations of key radionuclides can be estimated based on their relation to sediment traps constructed in this reach, and to trees that have been dated by dendrochronology (tree-ring dating). The first sediment traps were excavated in 1976 and had filled in by 1983 (LANL 1997, 56835; p. 2-8). Unique isotope ratio signatures in these deposits, reflecting the variable release history of different radionuclides from the TA-50 RLWTF, have been used to estimate ages of sampled sediment deposits in upstream reaches (isotope ratios in the effluent at any point in time varied with both the nature of contemporary research at LANL and on the treatment process at the RLWTF). For example, sediment with the lowest ratios of Pu-239,240 to Pu-238 (0.4-0.7) and americium-241 (Am-241) to Pu-238 (0.3-0.5) are present in the lower layers of the early sediment traps and in slightly older sediment deposited just downstream before the traps were created. These sediment deposits also have the highest concentrations of Cs-137 and Pu-238 in reach M-4, indicating that the highest levels of these radionuclides occurred in sediment deposited ca. 1976. Effluent records from the RLWTF show that the peak releases of Pu-238 were in 1974-1975 (LANL 1997, 56835; p. 2-20, 2-21), in turn indicating that within a few years floods had transported these constituents downstream to reach M-4. The peak release of Cs-137 is less well constrained by discharge records, but the correspondence of Cs-137 and Pu-238 peaks in sediment deposits suggests that Cs-137 also had maximum releases ca. 1974-1975.

Somewhat different histories are seen for Am-241 and Pu-239,240. In reach M-4, the highest levels of these analytes occur in slightly younger sediments in the early sediment traps, after 1976 but no later than 1983. These sediments have the lowest ratios of Cs-137 to Am-241 (0.6-0.9) and Pu-239,240 to Am-241 (0.5-0.6). Effluent records from the RLWTF indicate that the peak releases for Am-241 and Pu-239,240 were in 1981-1983 (LANL 1997, 56835; p. 2-20, 2-21), also providing evidence that floods rapidly transported these constituents downstream to M-4. Younger sediment deposits (post-1983) have lower concentrations of these key radionuclides, reflecting reduced releases from the RLWTF. Barring an increase in releases from the RLWTF, concentrations in sediments carried by floods should stay well below the peak levels that occurred ca. 1976-1983.

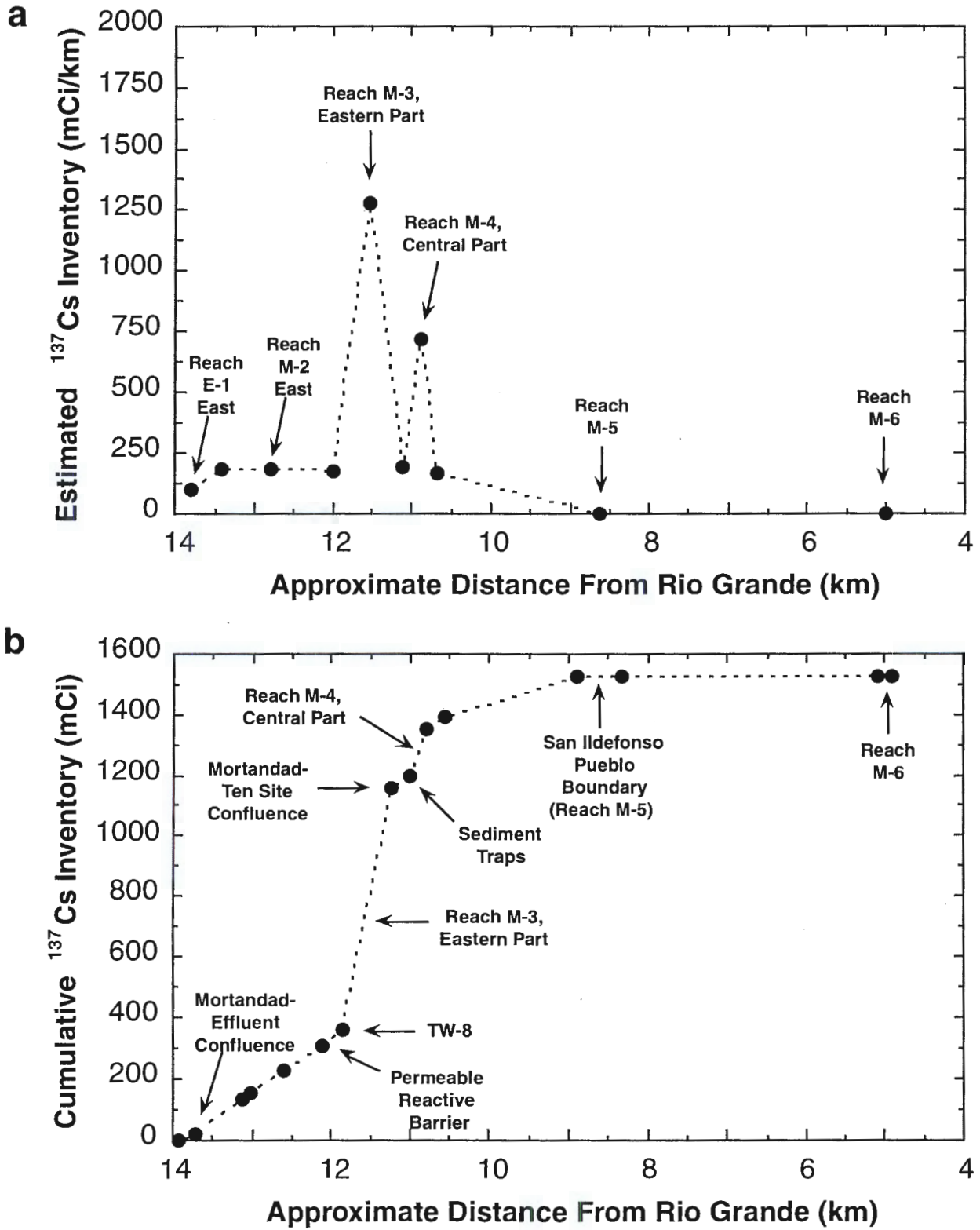

Figure 1. Preliminary estimate of Cs-137 inventory in Mortandad Canyon: (a) normalized inventory and (b) cumulative inventory

## **REMAINING MORTANDAD CANYON ACTIVITIES**

A series of tasks are required in Mortandad Canyon to complete the investigations presented in the work plan. These include collecting additional sediment samples to address uncertainties in the nature, extent, and concentration of COPCs; collecting surface water and groundwater samples; and potentially developing and implementing a biological investigation. Additional sampling of sediment in the Mortandad Canyon reaches is planned for Fall 2003, and may be followed by additional sampling in 2004 if data needs remain. Data needs for groundwater and surface water are being addressed in a separate groundwater work plan addendum (in preparation). Assessment of the potential need for a biological investigation is planned for Fall 2003, with implementation in 2004 if a biological investigation is deemed necessary. In addition to sampling associated with implementation of the Mortandad Canyon Work Plan, sampling planned at TA-35 as part of the NMED-approved Sampling and Analysis Plan for the Middle Mortandad/Ten Site Aggregate (LANL 2002, 73092), including in Pratt Canyon, will also contribute to understanding contamination in Mortandad Canyon.

## **ACKNOWLEDGMENTS**

This work was conducted as part of the Los Alamos National Laboratory Environmental Restoration Project (currently the Risk Reduction and Environmental Stewardship-Remediation Services Project) under the supervision of Allyn Pratt and Kent Rich. The authors thank Jason Hall, Shannon Purdue, Deborah Steven, Joe Toya, and other members of the field team for their help with the field work; San Ildefonso Pueblo for access onto Pueblo land; and Joe English, Danny Katzman, Ellen Louderbough, Rich Mirenda, Mark Tardiff, and Tom Whitacre for helpful reviews.

## **REFERENCES**

Drakos, P., R. Ryti, S. Reneau, and K. Greene, September 2000. "Evaluation of Possible Sediment Contamination in the White Rock Land Transfer Parcel: Reach CDB-4," Los Alamos National Laboratory report LA-UR-00-5071, Los Alamos, New Mexico. (Drakos et al. 2000, 68739)

EPA (US Environmental Protection Agency), 1989. "Risk Assessment Guidance for Superfund (RAGS), Volume 1, Human Health Evaluation Manual (Part A)," OSWER Directive 9285.7-01A, Office of Emergency and Remedial Response, Washington, D.C. (EPA 1989, 08021)

ESP (Environmental Surveillance Program), September 1998. "Environmental Surveillance at Los Alamos During 1997," Los Alamos National Laboratory report LA-13487-ENV, Los Alamos, New Mexico. (ESP 1998, 59904)

ESP (Environmental Surveillance Program), September 2002. "Environmental Surveillance at Los Alamos During 2001," Los Alamos National Laboratory report LA-13979-ENV, Los Alamos, New Mexico. (ESP 2002, 73806)

Fresquez, P. R., D. R. Armstrong, and M. A. Mullen, 1998. "Radionuclides in soils collected from within and around Los Alamos National Laboratory: 1974-1996," *Journal of Environmental Science and Health*, v. A33, no. 2, p. 263-278. (Fresquez et al. 1998, 76063)

Katzman, D., September 26, 2002. "Los Alamos/Pueblo Surface Aggregate Report – Record of Communication #1," Los Alamos National Laboratory, Environmental Restoration Project Memorandum ER2002-0690. (Katzman 2002, 73667)

LANL (Los Alamos National Laboratory), July 1997. "Interim Action Report for Potential Release Site 50-006(a), TA-50," Los Alamos National Laboratory report, Los Alamos, New Mexico. (LANL 1997, 55834)

LANL (Los Alamos National Laboratory), September 1997. "Work Plan for Mortandad Canyon," Los Alamos National Laboratory report LA-UR-97-3291, Los Alamos, New Mexico. (LANL 1997, 56835)

LANL (Los Alamos National Laboratory), August 1999. "Response To Request For Supplemental Information For Work Plan For Mortandad Canyon, Los Alamos National Laboratory, NM 0890010515 (NMED Comments, LANL Response)", Los Alamos National Laboratory letter EM/ER:99-024, Los Alamos, New Mexico. (LANL 1999, 62777)

LANL (Los Alamos National Laboratory), March 2002. "Sampling and Analysis Plan for the Middle Mortandad/Ten Site Aggregate," Los Alamos National Laboratory report LA-UR-02-0244, Los Alamos, New Mexico. (LANL 2002, 73092)

McDonald, E., R. T. Ryti, S. L. Reneau, and D. Carlson, May 2, 2003. "Natural Background Geochemistry and Statistical Analysis of Sediments, Los Alamos National Laboratory," Los Alamos National Laboratory report LA-UR-03-2661, Los Alamos, New Mexico. (McDonald et al. 2003, 76084)

NMED (New Mexico Environment Department), March 24, 2000. "Guidance for Assessing Ecological Risks Posed by Chemicals: Screening Level Ecological Risk Assessment," New Mexico Environment Department, Hazardous and Radioactive Materials Bureau, Santa Fe. (NMED 2000, 70107)

NMED (New Mexico Environment Department), December 12, 2002. "Approval Of Work Plan For Mortandad Canyon," New Mexico Environment Department Letter to Everett Trollinger

(Project Manager, DOE/OLASO) and John Browne (Director, LANL) from John Young (Project Leader, NMED-HWB), Santa Fe, New Mexico. (NMED 2002, 73830)

Ryti, R., P. A. Longmire, D. E. Broxton, S. L. Reneau, and E. V. McDonald, May 7, 1998. "Inorganic and Radionuclide Background Data for Soils, Canyon Sediments, and Bandelier Tuff at Los Alamos National Laboratory," Los Alamos National Laboratory report LA-UR-98-4847, Los Alamos, New Mexico. (Ryti et al. 1998, 59730)

WGII (Washington Group International, Inc.), October 2000. "Mortandad Canyon Sediment Trap Maintenance, Final Closeout Report," Washington Group International, Inc., Los Alamos, New Mexico. (WGII 2000, 70735)









SEP 22 2003

Risk Reduction & Environmental Stewardship Division  
Water Quality & Hydrology Group (RRES-WQH)  
PO Box 1663, MS K497  
Los Alamos, New Mexico 87545  
(505) 667-7969/Fax: (505) 665-9344

Date: September 17, 2003  
Refer to: RRES-WQH: 03-161

Mr. Curt Frischkorn  
Pollution Prevention Section  
Ground Water Quality Bureau  
New Mexico Environment Department  
P.O. Box 26110  
Santa Fe, New Mexico 87502

**SUBJECT: REQUEST FOR ADDITIONAL INFORMATION, TA-50 RADIOACTIVE LIQUID WASTE TREATMENT FACILITY, GROUND WATER DISCHARGE PLAN (DP-1132)**

Dear Mr. Frischkorn:

Per your request, please find the enclosed map, *Ground Water Wells in the Mortandad Canyon Area* (LA-UR-03-4596, July 2003). Further, you asked that the following information be displayed: NPDES Outfall 051; alluvial, intermediate and regional aquifer monitoring wells; Permeable Reactive Barrier (PRB) and associated monitoring wells; sediment traps; and technical area boundaries. Additionally, for your information, I have included stream gaging station GS-1 and several regional aquifer monitoring and supply wells in the vicinity of Mortandad Canyon.

Please contact me at (505) 667-7969 if you have any questions regarding this map.

Sincerely,

A handwritten signature in black ink, appearing to read 'Bob Beers'.

Bob Beers  
Water Quality & Hydrology Group

BB/jr

Enclosures: a/s

Cy: J. Vozella, DOE/OLASO, w/o enc., MS A316  
G. Turner, DOE/OLASO, w/enc., MS A316  
M. Johansen, DOE/OLASO, w/enc., MS A316  
J. Holt, ADO, w/o enc., MS A104  
D. McLain, FWO-WFM, w/o enc., MS J593  
R. Alexander, FWO-WFM, w/enc., MS E518  
B. Ramsey, RRES-DO, w/o enc., MS J591  
K. Hargis, RRES-DO, w/o enc., MS J591  
T. George, RRES-DO, w/o enc., MS J591  
D. Stavert, RRES-EP, w/o enc., MS J591  
S. Rae, RRES-WQH, w/enc., MS K497  
D. Rogers, RRES-WQH, w/enc., MS K497  
P. Wardwell, LC-ESH, w/o enc., MS A187  
RRES-WQH File, w/enc., MS K497  
IM-5, w/enc., MS A150



**NM Environmental Health Conference  
October 20-22, 2003**

Radioactive Liquid Waste Treatment Facility at LANL  
and  
Wastewater Treatment and Reuse at LANL

Pete Worland, RLWTF Process Engineer



History of Radioactive Liquid Waste Management at LANL

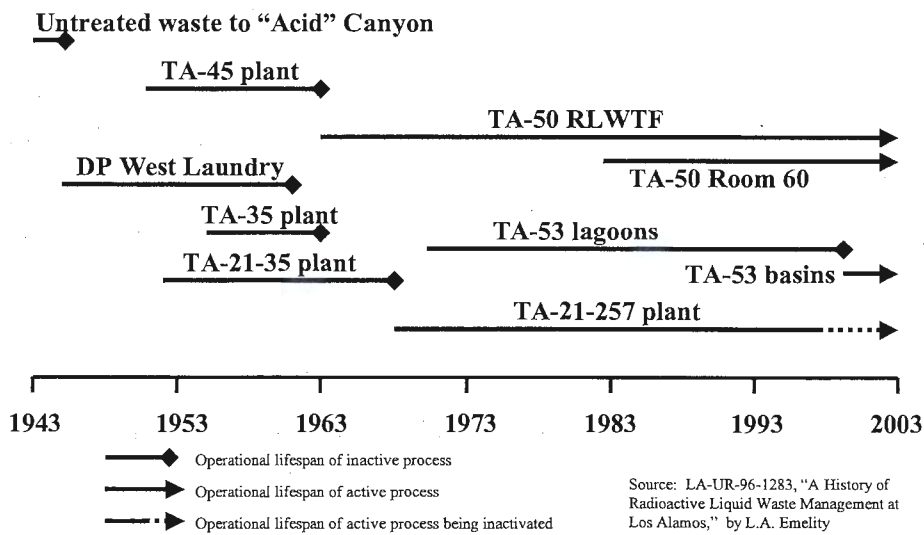

## TA-50 RLW Treatment Facility

- Startup in 1963
- Additions in 1966, 1984 and 1999
- 55,000 sq. ft.



NISA

Los Alamos

## Radioactive Liquid Waste Collection System

- 11,000 cubic meters/year (2002)
- Double contained pipeline
- 1,600 sinks, sumps, and tank pump down locations

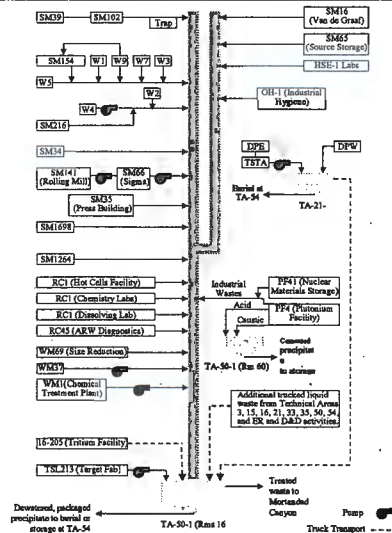

NISA

Los Alamos

## RLWTF Discharges (1963 – 2002)

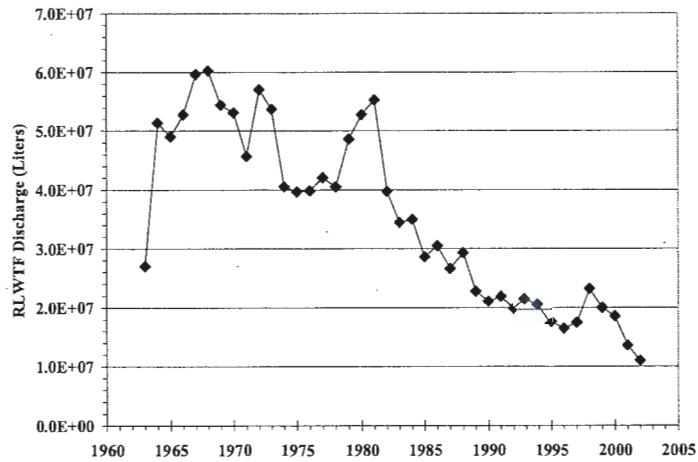

NISA

Los Alamos

## RLWTF Flow Schematic (CY 2002 basis)

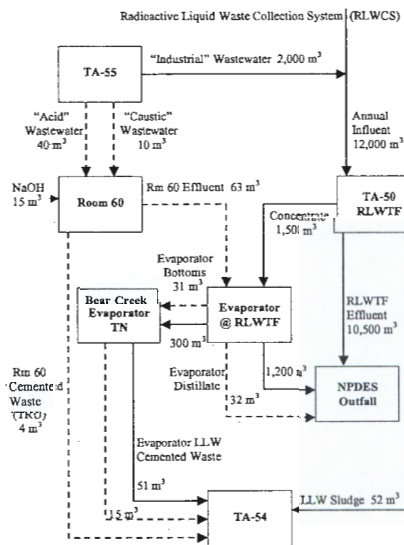

NISA

Los Alamos

## Schematic of RLWTF Treatment Process

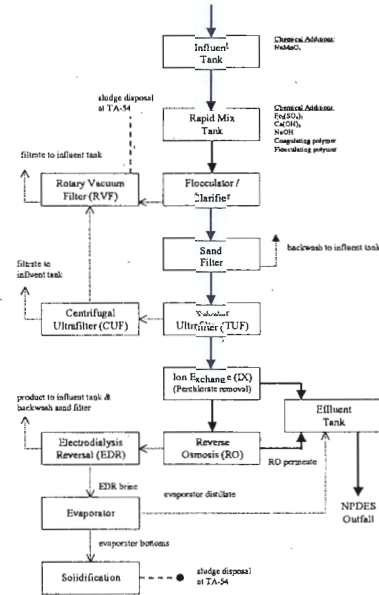

NISA

Los Alamos

## RLWTF Process Flow Diagram

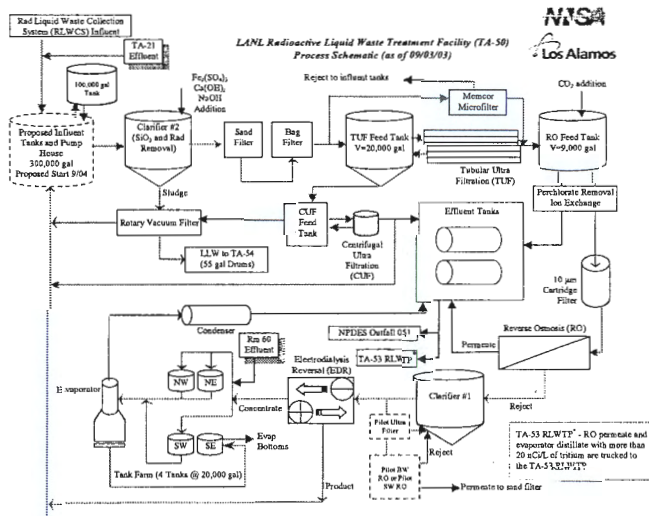

NISA

Los Alamos



## Computer Control / SCADA

---

- RS View operation / control system
- Remote monitoring and control
- Several hundred instruments at RLWTF, RLWCS and remote facilities

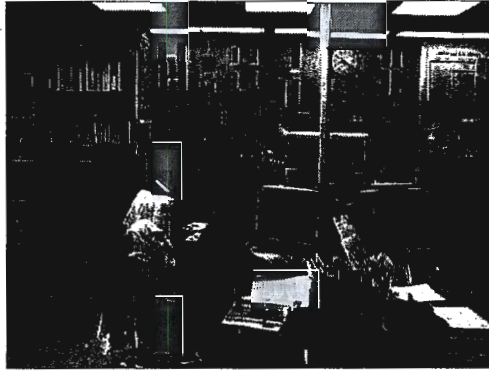

NVSA

Los Alamos

## Coagulation-Flocculation-Sedimentation

---

- Ferric sulfate, lime, NaOH, polymer additions
- 95% removal of gross alpha
- Sludge dewatered by a rotary vacuum filter

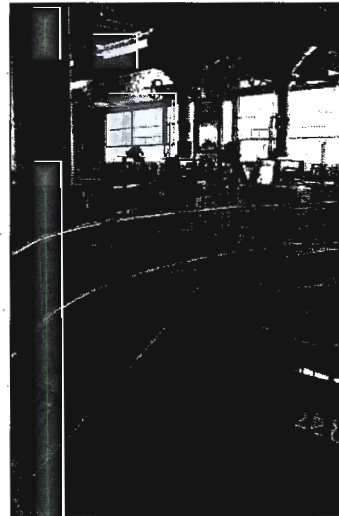

NVSA

Los Alamos

## Particle Size Removal Capability of Membrane Filtration Technologies

Dissolved Contaminants		Suspended Contaminants			
< 0.01 $\mu\text{m}$		> 0.01 $\mu\text{m}$			
		Colloids 0.01 - 1 $\mu\text{m}$		Particulate > 1 $\mu\text{m}$	
< 0.001 $\mu\text{m}$	0.001 - 0.01 $\mu\text{m}$	0.01 - 0.1 $\mu\text{m}$	0.1 - 1 $\mu\text{m}$	Fine 1-10 $\mu\text{m}$	Coarse > 10 $\mu\text{m}$
		MICROFILTRATION			
		ULTRAFILTRATION			
		NANOFILTRATION			
REVERSE OSMOSIS					

David H. Paul, 2002, QpEzr, AWWA, V.28, No.5

**NISA**

Los Alamos

### Tubular Ultrafilter (TUF)

- Processing rate 65 gpm
- Feed: clarifier / sand filter effluent
- 350 membranes (each tube is 10 feet long and 1 inch in diameter)
- Pore size: 0.008 micron
- Function: fine particulate removal

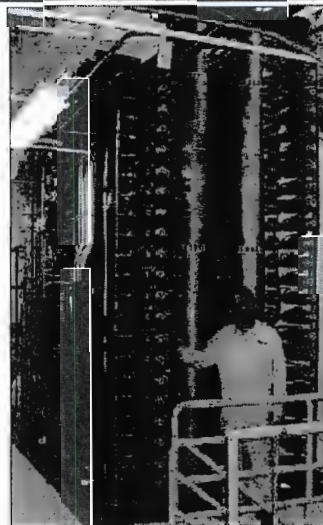

**NISA**

Los Alamos

## Perchlorate Removal by Ion Exchange (IX)

- Sybron SR-7: a perchlorate specific IX resin
- All RLWTF effluent is treated by this resin to remove perchlorate to less than 4 ppb



**NISA**

 Los Alamos

## Reverse Osmosis (RO)

- Processing rate: 70 gpm
- Feed: tubular ultrafilter permeate
- 2 stage (2:1 array)
- 90% water recovery
- Batch operation
- Silica management
- Removes dissolved contaminants

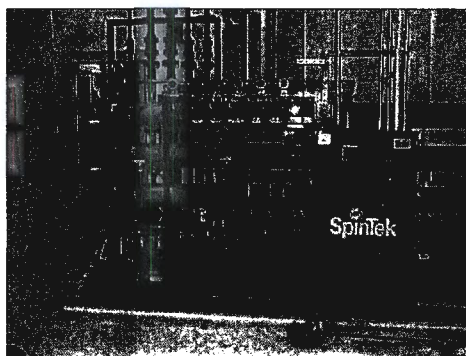

**NISA**

 Los Alamos

## Centrifugal Ultrafilter (CUF)

- Processing rate: 2 gpm
- Feed: tubular ultrafilter concentrate
- 25 membrane plates spinning at 1,300 rpm
- Average pore size: 0.1 micron
- Removes particulates and organics

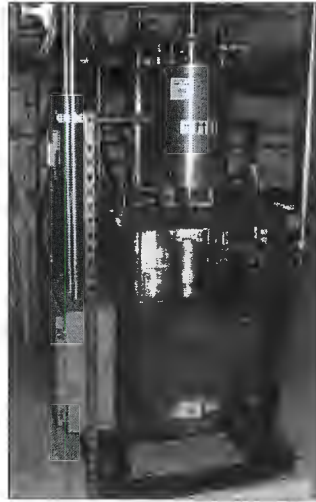

NISA

Los Alamos

## Electrodialysis Reversal (EDR)

- Concentrates ions by direct electric current
- Purpose: volume reduces RO concentrate



NISA

Los Alamos

## Volume Reduction Evaporator

- Processing rate: 7 gpm
- Feed: EDR concentrate
- "Bottoms" to offsite location for evaporation to dryness
- Distillate to NPDES outfall



NISA

Los Alamos

## USEPA Discharge Limits for RLWTF Effluent

NPDES Parameters	Monthly Average (mg/L) Report	Daily Max (mg/L) Report
Flow		
pH	6-9 su	6-9 su
Chemical Oxygen Demand	125	125
Total Suspended Solids	30	45
Total Cadmium	0.05	0.05
Total Chromium	1.34	2.68
Total Copper	1.393	1.393
Total Iron	-----	-----
Total Lead	0.423	0.524
Total Mercury	0.00077	0.00077
Total Zinc	4.37	8.75
Total Toxic Organics	1.0	1.0
Total Arsenic	0.368	0.368
Total Aluminum	5.0	5.0
Total Boron	5.0	5.0
Total Cobalt	1.0	1.0
Total Selenium	0.005	0.005
Total Vanadium	0.1	0.1
Radium 226 + Radium 228	30 pCi/L	30 pCi/L
Tritium (when accelerator produced)	20,000 pCi/L	20,000 pCi/L
Total Nickel	Report	Report
Perchlorate	Report	Report

NISA

Los Alamos

## NMED Discharge Limits for RLWTF Effluent

NMED Parameters	Per Discharge (mg/L)
Fluoride	1.6
Nitrate-nitrogen	10.0
Total Dissolved Solids	1,000

**NISA**

 **Los Alamos**

## Radiation Protection of the Public and the Environment (DOE Order 5400.5)

- Order 5400.5 was issued in 1990 to ensure that no person would receive greater than 100 mrem of effective dose equivalent by drinking 730 liters (2 liters/day) of water in a one year period. Each radionuclide has an activity in 730 liters of water that would equal a 100 mrem dose per year. This concentration is known as the "Derived Concentration Guideline" (DCG) for that particular radionuclide. For example, the DCG value for Plutonium-239 is 30 pCi/L.
- When more than one radionuclide is present in the water, a technique known as the "Sum of the Ratios" is used to ensure that the 100 mrem dose limit is not exceeded. The ratio of each nuclide's concentration to its DCG value is calculated. As long as the "Sum of the Ratios" is less than 1.0, the effective dose equivalent will be less than 100 mrem per year. (see example to the right)

	DCG			
	pCi/L	uCi/ml	pCi/L	Ratios
Am-241	4	3.00E-08	30	0.13
Cs-137	170	3.00E-06	3000	0.06
H-3	7100	2.00E-03	2000000	0.00
Rb-83	NDA	2.00E-05	20000	0.00
Pu-238	4	4.00E-08	40	0.10
Pu-239	4	3.00E-08	30	0.13
Sr-89	14	2.00E-05	20000	0.00
Sr-90	20	1.00E-06	1000	0.02
U-234	4.1	5.00E-07	500	0.01
U-235	0.25	6.00E-07	600	0.00
Mn-54	NDA	5.00E-05	50000	0.00
U-238	9.4	6.00E-07	600	0.02
			Sum =	<b>0.47</b>

**NISA**

 **Los Alamos**

## Reduction in Nitrate-Nitrogen Discharged

Nitrate-Nitrogen in RLWTF Effluent January 1999 through July 2003

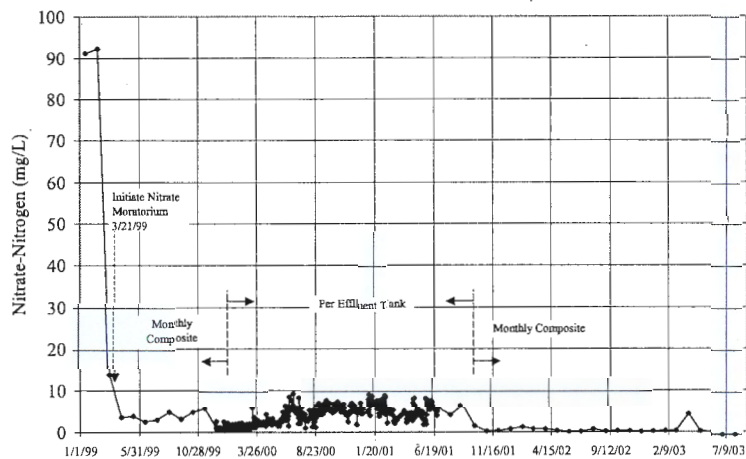

NISA

Los Alamos

## Perchlorate Reduction in RLWTF Effluent

Perchlorate in RLWTF Influent and Effluent from May 2001 - August 2003  
Analysis of Flow Weighted Weekly Composite Samples

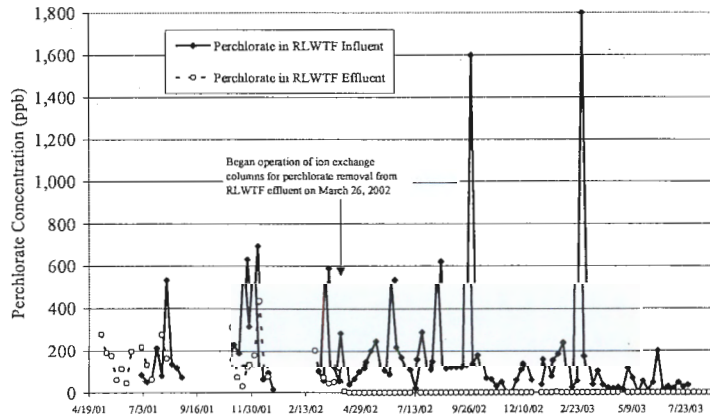

NISA

Los Alamos

## Tritium Reduction in RLWTF Effluent

Tritium in Final Monthly Composite Samples (1/99 - 7/03)

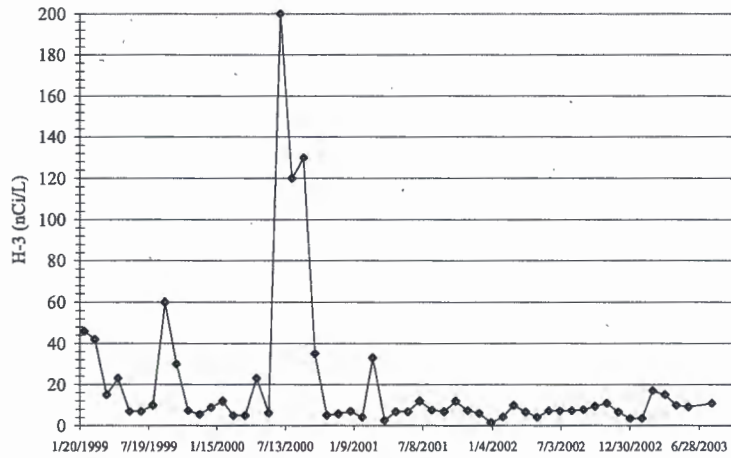

NISA

Los Alamos

## Reduction in Radioactive Material Discharged to the Environment

Monthly and 12 Month Running Average of RLWTF Effluent from December 1998 through June 2003 (55 months) Analysis of Flow Weighted Monthly Composite Samples

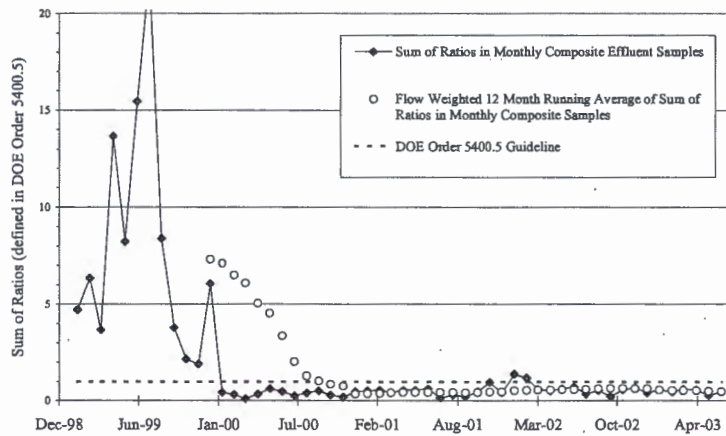

NISA

Los Alamos



## Regulations and RLWTF Upgrades

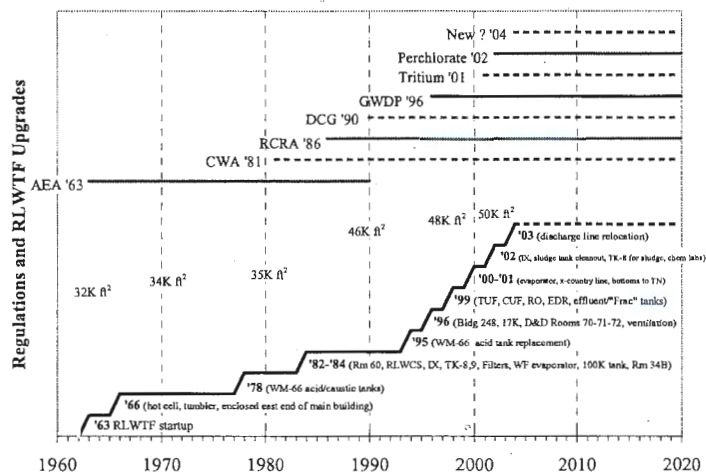

NVSA

Los Alamos

## RLWTF Future Plans

- Continue to meet institutional requirements for RLW treatment in support of programmatic needs
- Continue to remain under Federal and State regulatory permit requirements
- Continue to achieve ALARA goals (per DOE Order 5400.5) for discharges to the environment
- New influent tank farm and pump house
- New facility
- Zero liquid discharge

NVSA

Los Alamos

### Los Alamos National Laboratory Recycled Wastewater Flow Path

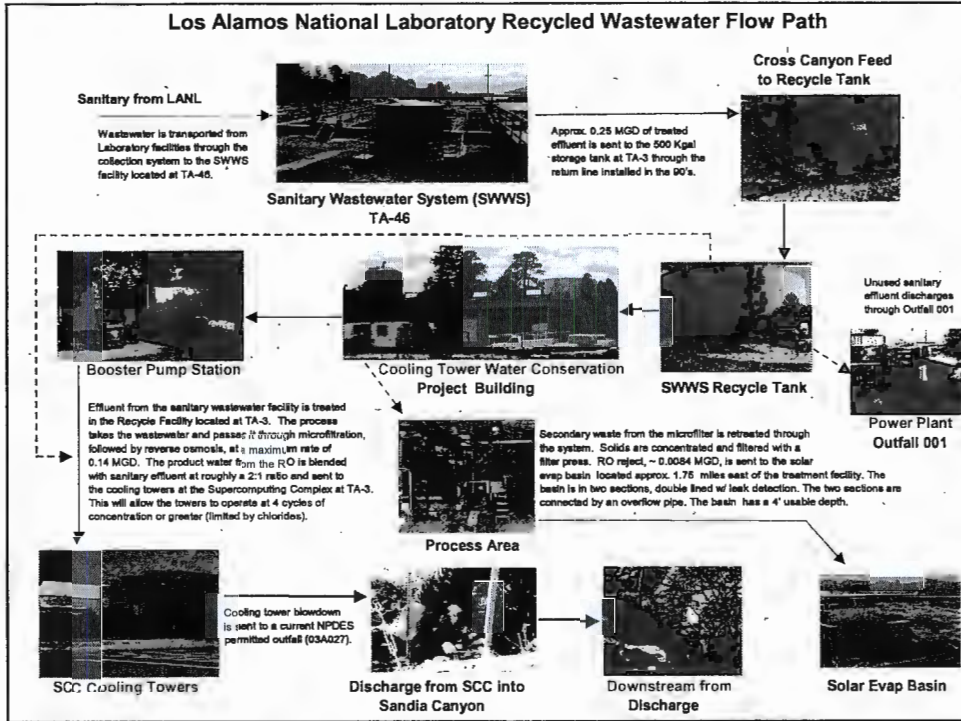

### LANL Sanitary Wastewater Effluent

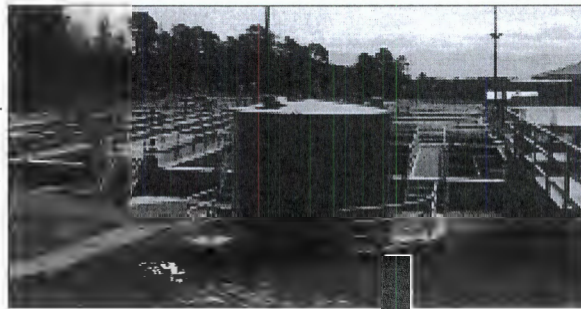

## Sanitary Effluent Reclamation Facility (SERF)

---



**NNSA**

**Los Alamos**

## SCC Cooling Towers

---



**NNSA**

**Los Alamos**

## Solar Evaporation Basin

---

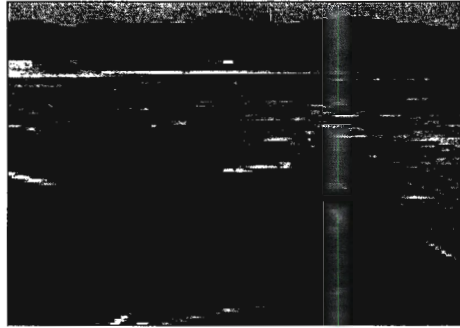

**NISA**

 **Los Alamos**

H

- Vant Arc Reader (Freeview)

Arc Publisher - creates file

Land Trek (www.landtrek.org)

↳ Cold Fusion - relates spatial data to Oracle.

- Kevin Trostman - Bern. Co/ABQ GIS 505-314-0321

NHD 83 - State Plane Fares/Data - Downloadable

→ Solar Dist - Solar Still - sells Mex

170°F - spike H<sub>2</sub>O/Ecoli - ND in product

Seawater TDS - 36,000ppm

- Distilled H<sub>2</sub>O cleaner than DI

6h/day - depends on sunlight/surface area of collector

↳ entirely for Drink H<sub>2</sub>O

- won't remove organics - run through GAC

- 1m<sup>2</sup> still - produces H<sub>2</sub>O for 2 people

- No biofilm formation (temp.)

- has outlet for flushing solids

Ent  
Er

RLWTF → ~3mg/yr (20,000g pot)

Acid Canyon - recd. untreated RAD waste

1963 - TA-00 online

TA-21 - being shut down.

Rm 60 - (TA-50) - high level

7mi - collection 6"/10" (1792 - installed)

TA-53 - solar evap. - tritium waste.

↳ 1999 - only treatment was grav. clarifi. flou.

150,000mg/l TDS - Evap bottoms - shipped to Tenn.

facility - dried/stabilized

≥ 100mcu/g - HLW (WIPP)

Treatment Plant - IB

Fine Clay Colloid  
settles slowly

Tide-behaviorant

→ Bilingual DVD - as soon as comic bk is done

↳ offered to Ana Maria Ortiz (END)

→ Texas A&M website - Bruce Lesikar

↳ maintained

DVD  
all 31/3/05





State of New Mexico Environment Department

Ground Water Bureau

1190 St. Francis Drive  
Santa Fe, NM 87505

Telephone: (505) 827-2905 Fax: (505) 827-2965

---

**INVOICE**

**Primary Billing Party:**  
Los Alamos National Laboratory  
PO Box 1663, MS J978  
Meteorology and Air Quality Group  
Los Alamos, NM 87545  
DP-1132 (N)

**Agency Interest:**  
856 - Los Alamos National Laboratory  
1 mile S of Los Alamos  
Los Alamos, NM 87545

**INVOICE ID:** 1494

**INVOICE DATE:** 10/31/2003

**INVOICE DUE DATE:** 11/30/2003

---

**ASSESSMENTS**

Ground Water, PRD20030002, 341 - Discharge Fee

\$3,450.00

**INVOICED AMOUNT**

\$3,450.00

---

**BALANCE DUE**

\$3,450.00

-----  
Cut Here and Include Lower Portion with Payment  
-----

**Primary Billing Party:**  
Los Alamos National Laboratory  
PO Box 1663, MS J978  
Meteorology and Air Quality Group  
Los Alamos, NM 87545  
DP-1132 (N)

**Agency Interest:**  
856 - Los Alamos National Laboratory  
1 mile S of Los Alamos  
Los Alamos, NM 87545

**INVOICE ID:** 1494

**INVOICE DUE DATE:** 11/30/2003

**Invoice Amount:** \$3,450.00

**Amount Enclosed** \_\_\_\_\_

**Please make checks payable to:**

**Mail payments to:**

**NMED Federal Tax ID#:** 85-6000565

**New Mexico Environment Department**

**Ground Water Quality Bureau**

**PO Box 26110**

**Santa Fe, NM 87502-6110**

**Telephone:** (505) 827-2905

**Fax:** (505) 827-2965

02221







*Risk Reduction & Environmental Stewardship Division  
Water Quality & Hydrology Group (RRES-WQH)*  
PO Box 1663, MS K497  
Los Alamos, New Mexico 87545  
(505) 667-7969/Fax: (505) 665-9344

Date: October 29, 2003  
Refer to: RRES-WQH: 03-278

Mr. Curt Frischkorn  
Ground Water Pollution Prevention Section  
Ground Water Quality Bureau  
New Mexico Environment Department  
P.O. Box 26110  
Santa Fe, New Mexico 87502

**SUBJECT: TA-50 RADIOACTIVE LIQUID WASTE TREATMENT FACILITY, GROUND WATER DISCHARGE PLAN (DP-1132) QUARTERLY REPORT, THIRD QUARTER 2003**

Dear Mr. Frischkorn:

This letter is intended to serve as Los Alamos National Laboratory's quarterly Ground Water Discharge Plan (DP-1132) report for the TA-50 Radioactive Liquid Waste Treatment Facility (RLWTF) for the third quarter of 2003. Since the first quarter of 1999, Los Alamos National Laboratory has provided your agency with voluntary quarterly reports containing analytical results from effluent and ground water monitoring.

Mortandad Canyon Alluvial Ground Water Monitoring Results

Table 1.0 presents the analytical results from sampling conducted at four Mortandad Canyon alluvial monitoring wells during the 3rd quarter of 2003. All of the analytical results from MCO-3, MCO-4B, MCO-6, and MCO-7 were below New Mexico Water Quality Control Commission (NM WQCC) Regulation 3103 standards for nitrate-nitrogen (NO<sub>3</sub>-N), fluoride (F), and total dissolved solids (TDS).

RLWTF Effluent Monitoring Results

Table 2.0 presents the analytical results from weekly monitoring of the RLWTF's effluent. The weekly samples are flow-proportioned composite samples prepared from each tank of effluent generated by the RLWTF during a 7-day period. Samples are submitted to General Engineering Laboratories (GEL), Charleston, SC, for analysis. All sample results from the 3rd quarter were below NM WQCC Regulation 3103 standards for NO<sub>3</sub>-N, F, and TDS.

Additionally, starting this quarter, the Laboratory will begin reporting the analytical results from monthly composite sampling of RLWTF's effluent for NO<sub>3</sub>-N and perchlorate. The monthly samples are flow-proportioned composite samples prepared from each tank of effluent generated by the RLWTF during the month. Sample analysis is performed by an internal analytical laboratory located at the TA-50 RLWTF. Perchlorate analysis is by EPA Method 314, Ion Chromatography. Table 3.0 presents the final monthly composite sample results for the 3<sup>rd</sup> quarter of 2003.

Please contact me at (505) 667-7969 if you would like additional information regarding this quarterly report.

Sincerely,

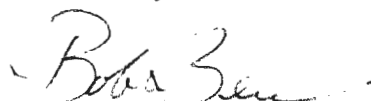

Bob Beers  
Water Quality & Hydrology Group

BB/lm

Cy: M. Leavitt, NMED/SWQB, Santa Fe, NM  
C. Voorhees, NMED/DOE/OB, Santa Fe, NM  
R. Ford-Schmid, NMED/DOE/OB, Santa Fe, NM  
J. Vozella, DOE/OLASO, MS A316  
G. Turner, DOE/OLASO, MS A316  
J. Holt, ADO, MS A104  
T. Stanford, FWO-DO, MS K492  
D. Mclain, FWO-WFM, MS J593  
R. Alexander, FWO-WFM, MS E518  
D. Moss, FWO-WFM, MS E518  
P. Worland, FWO-WFM, MS E518  
B. Ramsey, RRES-DO, MS J591  
K. Hargis, RRES-DO, MS J591  
D. Stavert, RRES-EP, MS J591  
S. Rae, RRES-WQH, MS K497  
D. Rogers, RRES-WQH, MS K497  
M. Saladen, RRES-WQH, MS K497  
RRES-WQH File, MS K497  
IM-5, MS A150

*Radioactive Liquid Waste Treatment Facility  
Ground Water Discharge Plan (DP-1132) Quarterly Report  
3rd Quarter, 2003*

**Table 1.0. Mortandad Canyon Alluvial Monitoring Wells Analytical Results, 3rd Quarter, 2003.**

Sampling Location	Sample Date	Perchlorate <sup>3</sup> (ug/L)	NO3/NO2-N (mg/L)	TKN (mg/L)	NH3-N (mg/L)	TDS (mg/L)	F (mg/L)
MCO-3	8/11/2003	2.35J	2.81	0.34	<0.024	310	0.621
MCO-4B	8/13/2003	10.4	2.4	0.30	<0.024	400	0.865
MCO-6	8/14/2003	15.8	2.78	0.24	<0.024	415	0.940
MCO-7	8/14/2003	60.4	3.50	0.23	<0.024	342	1.21
<i>NM WQCC 3103. Ground Water Standards (mg/L)</i>			$10^2$			1000	1.6

**Notes:**

<sup>1</sup>NS means that there was not sufficient water available for sampling.

<sup>2</sup>The NMWQCC Regulation 3103. Ground Water Standard is for NO<sub>3</sub>-N.

<sup>3</sup>Nonfiltered sample.

J indicates an estimated value. The result was less than the reporting limit, but greater than the detection limit.

All analyses by General Engineering Laboratories, Charleston, SC.

All samples filtered unless otherwise noted.

10/27/2003

*Radioactive Liquid Waste Treatment Facility  
Ground Water Discharge Plan (DP-1132) Quarterly Report  
3rd Quarter, 2003*

**Table 2.0. RLWTF Weekly Effluent Monitoring Analytical Results, 3rd Quarter, 2003.**

Monitoring Period	Composite Date	RLWTF Weekly Effluent Monitoring Analytical Results (mg/L)		
		NO3+NO2-N	Fluoride	TDS
<u>JUNE, 2003</u>	6/24/2003	<0.01	<0.06	109
	6/30/2003	<0.01	0.10	134
<u>JULY, 2003</u>	7/7/2003	<0.01	0.13	124
	7/15/2003	0.02J	0.15	121
	7/18/2003	0.04J	0.16	143
	7/29/2003	<0.01	0.15	183
<u>AUGUST, 2003</u>	8/5/2003	0.07	0.16	143
	8/13/2003	0.05	0.07J	75
	8/19/2003	0.18	0.12	105
	8/26/2003	0.58	0.12	81
<u>SEPTEMBER, 2003</u>	9/3/2003	0.39	0.16	150
	9/9/2003	0.36	0.10	126
	9/15/2003	0.67	0.16	129
	9/23/2003	0.70	0.16	61
<b>3rd Quarter 2003 Averages (mg/L)</b>		<b>0.22</b>	<b>0.13</b>	<b>120</b>
<i>NM WQCC 3103. Ground Water Standards (mg/L)</i>		<i>10.0<sup>4</sup></i>	<i>1.6</i>	<i>1000</i>

**Notes:**

<sup>1</sup>Results for these analyses are pending validation.

<sup>2</sup>A duplicate sample result.

<sup>4</sup>The NMWQCC Regulation 3103. Ground Water Standard is for NO3-N

All analyses by the General Engineering Laboratories, Charleston, South Carolina.

*Radioactive Liquid Waste Treatment Facility  
Ground Water Discharge Plan (DP-1132) Quarterly Report  
3rd Quarter, 2003*

**Table 3.0. RLWTF Monthly Effluent Monitoring Analytical Results, 3rd Quarter, 2003.**

Monitoring Period	Final Monthly Composite (FMC) Analytical Results	
	NO <sub>3</sub> -N (mg/L)	Perchlorate (ug/L)
<u>JULY, 2003</u>	0 (+/-0.01)	0 (+/- 1)
<u>AUGUST, 2003</u>	0.08 (+/-0.01)	0 (+/- 1)
<u>SEPTEMBER, 2003</u>	0.2 (+/-0.02)	0 (+/- 1)
<i>NM WQCC 3103. Ground Water Standards</i>	<i>10.0</i>	<i>NA</i>

**Notes:**

All analyses by the Laboratory's TA-50 RLWTF analytical laboratory.



**TA-50**  
**RADIOACTIVE LIQUID WASTE TREATMENT FACILITY**  
**GROUND WATER DISCHARGE PLAN HISTORY**

Presentation To:

NMED

CCNS

Tewa Women United

Bob Beers

Risk Reduction and Environmental Stewardship  
Water Quality and Hydrology Group

November 10, 2003



UNCLASSIFIED



# Proposed Schedule

---

---

- **Drilling and Field Activities**
  - o Oct 2003 - December 2004
- **Sample Collection and Analysis**
  - o July 2004 - July 2005
- **Report Preparation**
  - o July 2005 - December 2005
- **Report Submittal:**
  - o December 31, 2005



**TA-50 RLWTF  
DISCHARGE PLAN ACCOMPLISHMENTS**

- Since Mar-99 Effluent Meets WQCC Standards (nitrate & fluoride)
- Since Dec-99 Effluent Meets DOE DCGs (AEA radionuclides)
- Since Oct-00 Tritium Reductions in Effluent (below EPA MCL)
- Since Mar-02 IX Treatment for ClO<sub>4</sub> Removal (below detection)



UNCLASSIFIED



## TA-50 RLWTF DISCHARGE PLAN HISTORY

- Apr-96 NMED Request for Discharge Plan
- Aug-96 Discharge Plan Submitted
- Nov-96 Public Notice Issued
- Apr-97 to Sep-98 Requests/Replies for Additional Info
- Sep-98 NMED Letter of Non-Compliance
- Feb-99 Request/Reply for Additional Info
- Mar-99 Nitrate Moratorium Implemented

# TA-50 RLWTF DISCHARGE PLAN HISTORY

02253

Nitrate-Nitrogen in RLWTF Effluent January 1999 through July 2003

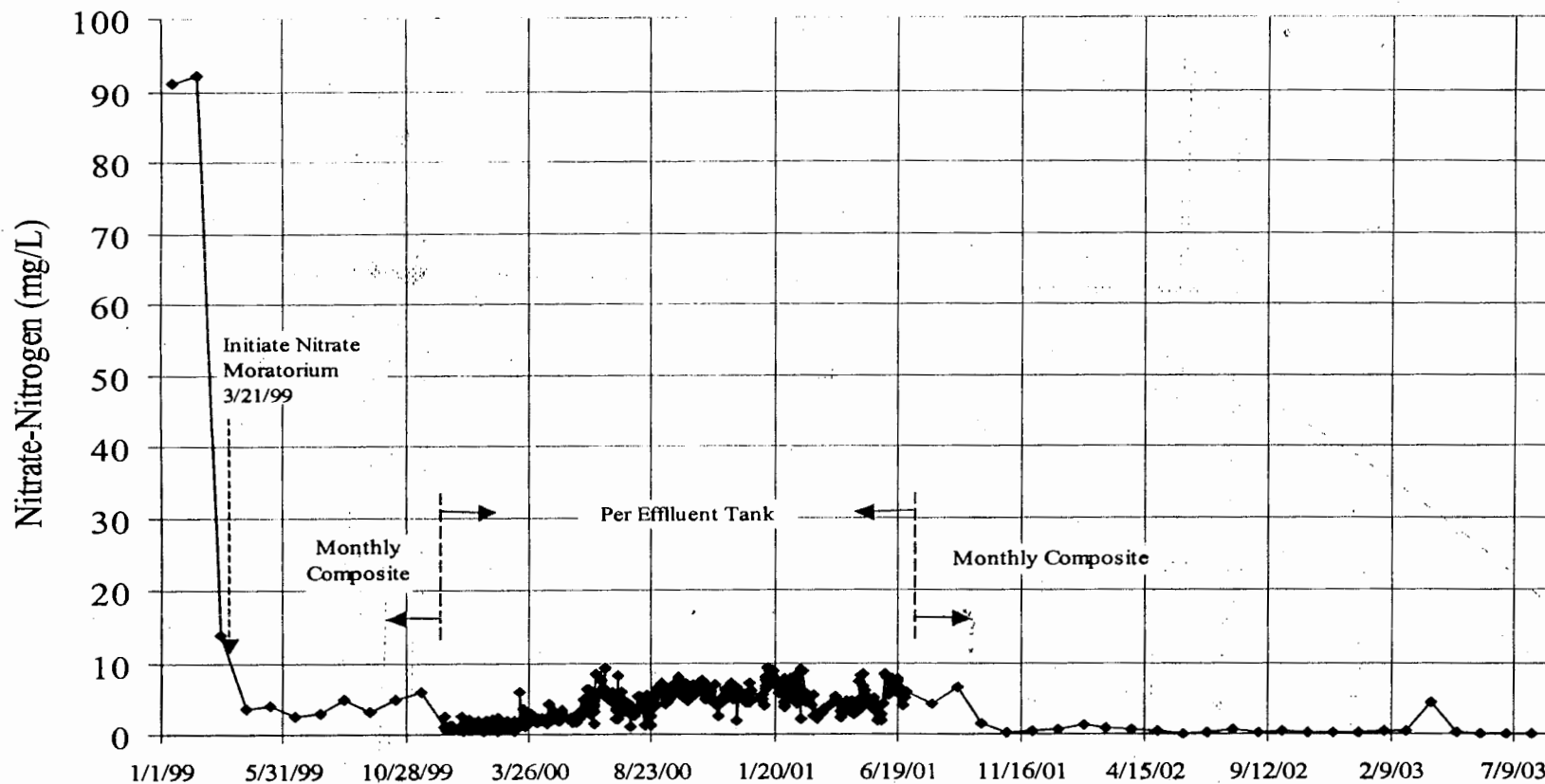

# TA-50 RLWTF DISCHARGE PLAN HISTORY

➤ March 21, 1999

Effluent Meets WQCC Standards

➤ Apr-99

Phase I—TUF and RO Start-Up

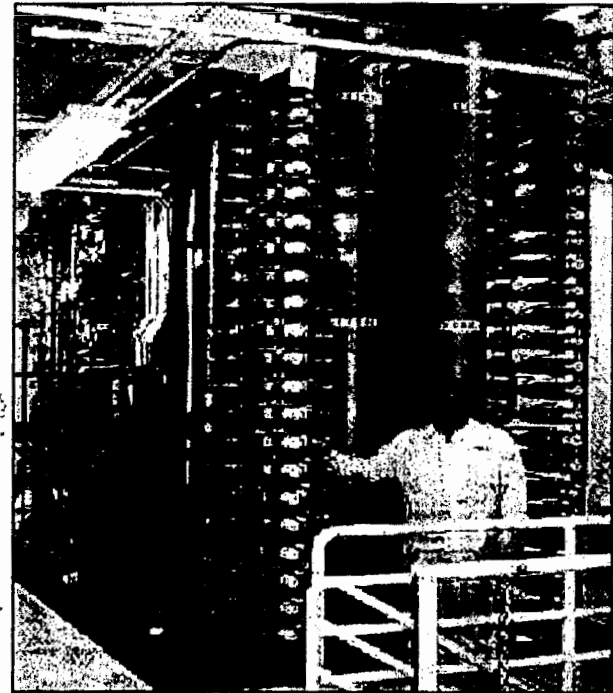
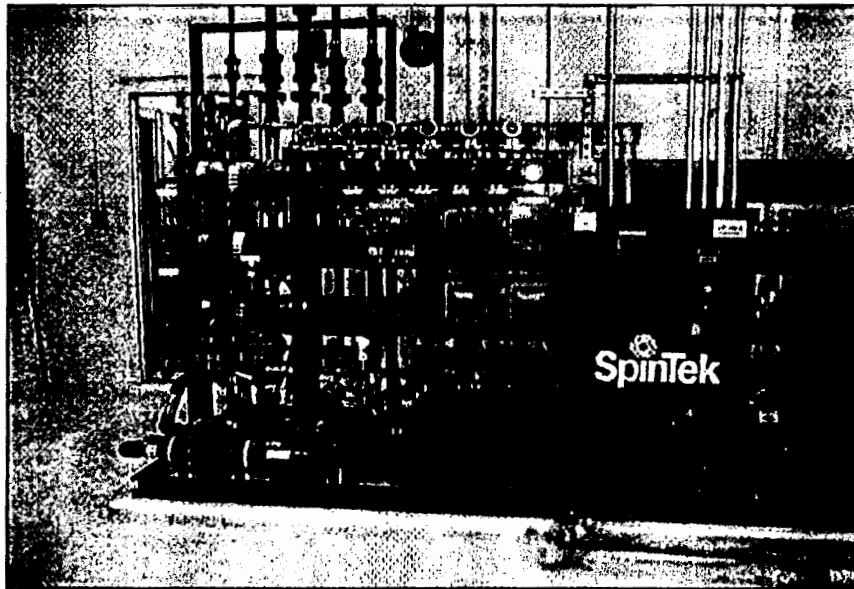

# TA-50 RLWTF DISCHARGE PLAN HISTORY

02235

➤ May-99

Voluntary Qtrly Reporting by LANL

➤ Jan-00

Phase II—EDR Start-Up

➤ Jan-00

Phase II—Evaporator Start-Up

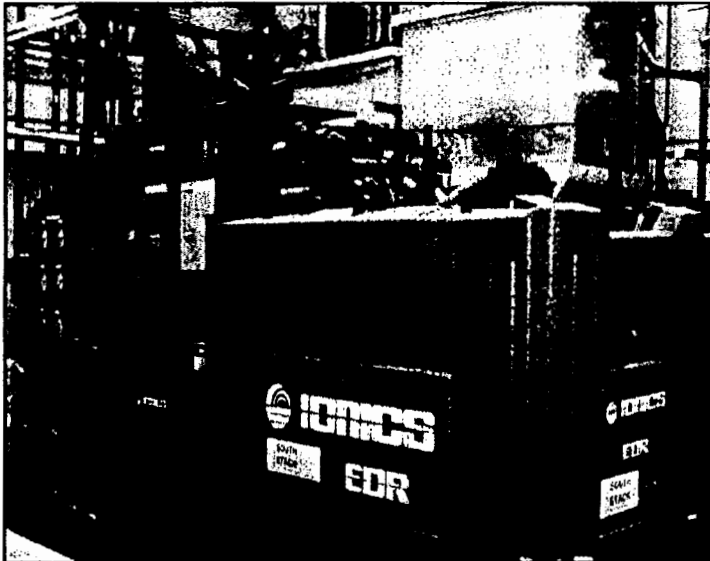

# TA-50 RLWTF DISCHARGE PLAN HISTORY

92236

➤ Jan-02

Request/Reply for Additional Info

➤ Aug-03

NMED Reissues Public Notice

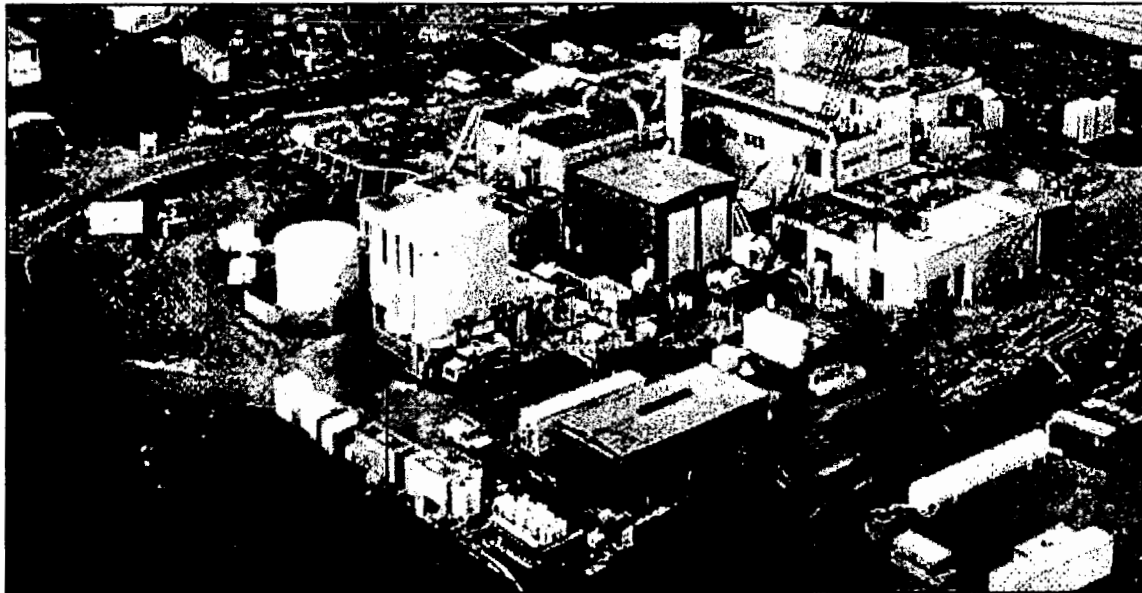

# TA-50 RLWTF DISCHARGE PLAN HISTORY

## Related Milestones

- Dec-99 to present RLWTF Meets DOE DCGs
- Oct-00 Tritium Reductions in Effluent
- Mar-02 IX Treatment for  $\text{ClO}_4$  Removal

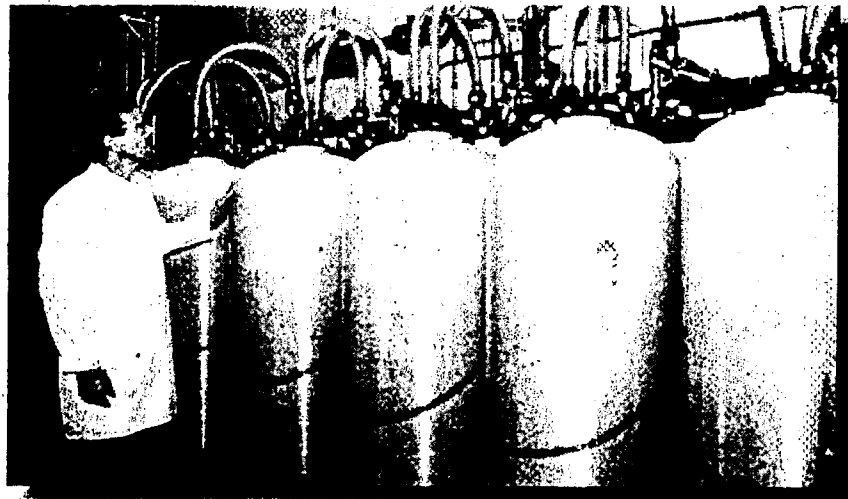

# Radioactive Material—Reduction in RLWTF Effluent

Monthly and 12 Month Running Average of RLWTF Effluent from December 1998 through June 2003 (55 months) Analysis of Flow Weighted Monthly Composite Samples

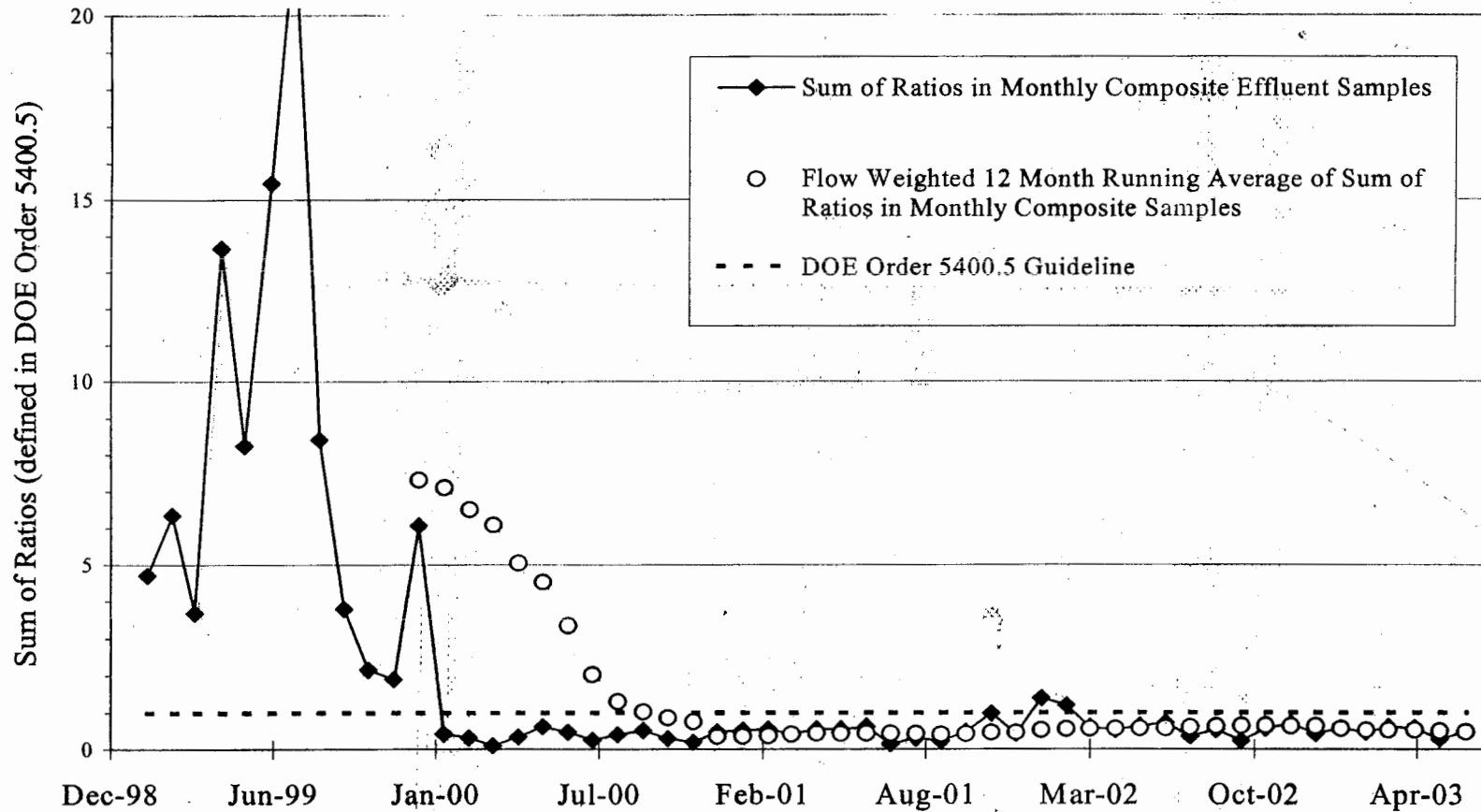



# Tritium—Reduction in RLWTF Effluent

Tritium in Final Monthly Composite Samples (1/99 - 7/03)

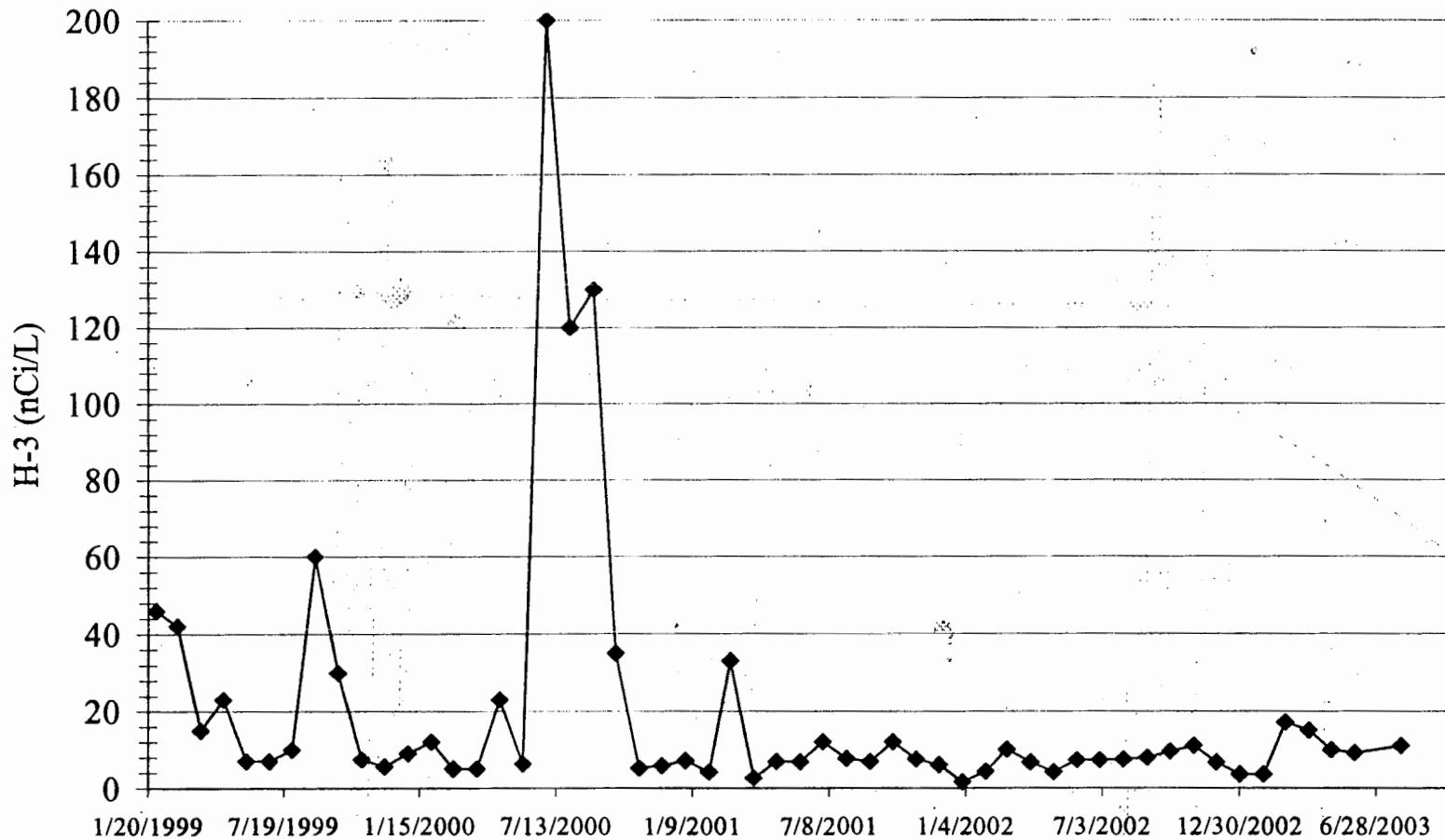

# Perchlorate—Reduction in RLWTF Effluent

Perchlorate in RLWTF Influent and Effluent from May 2001 - August 2003  
Analysis of Flow Weighted Weekly Composite Samples

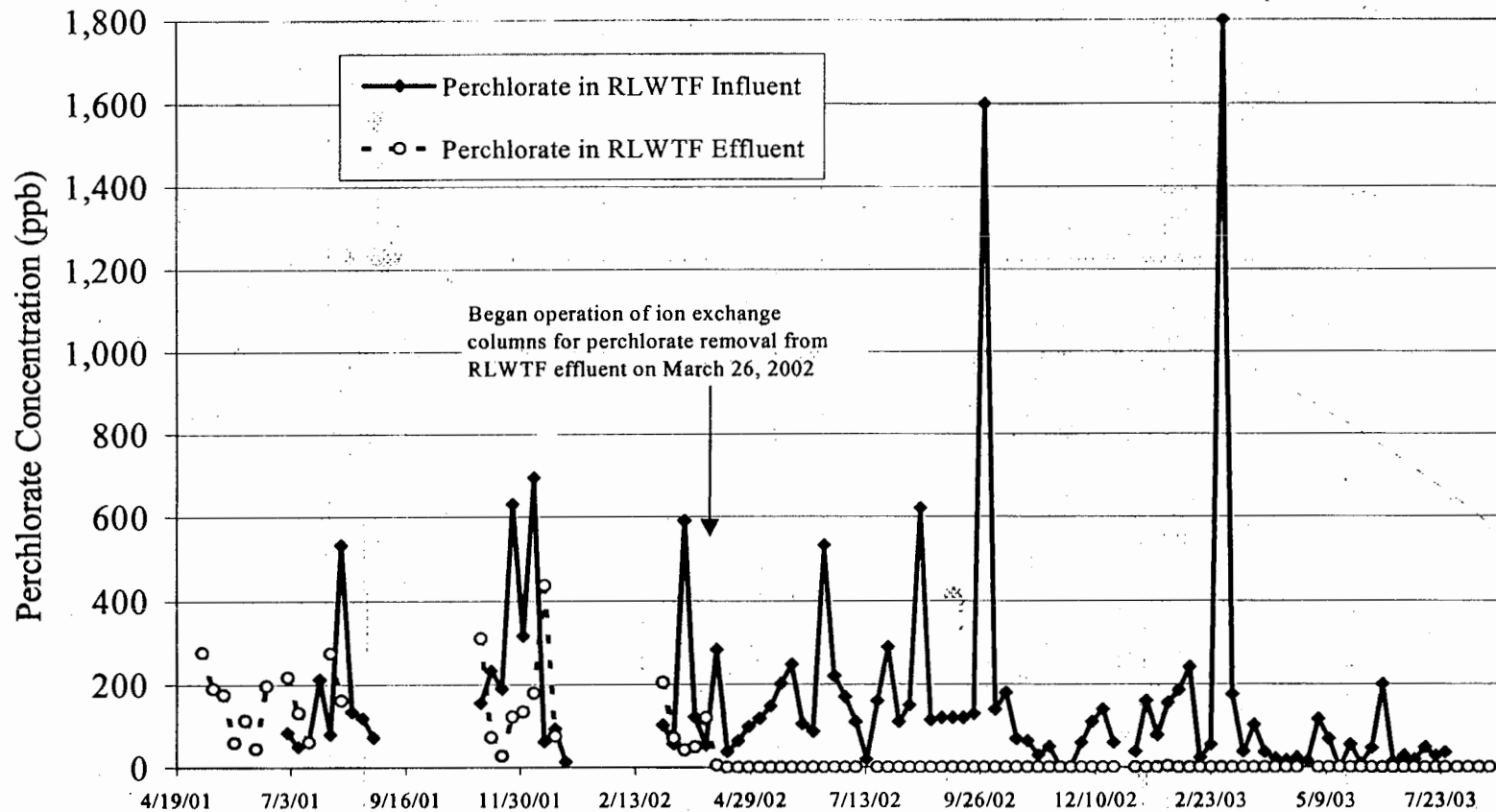

# Nitrate-Nitrogen in RLWTF Effluent Discharges

NMED Groundwater Standard = 10 mg/L  
Average from 12/10/99 - 6/30/01  
is 3.9 mg/L NO<sub>3</sub>-N  
(372 effluent tanks)

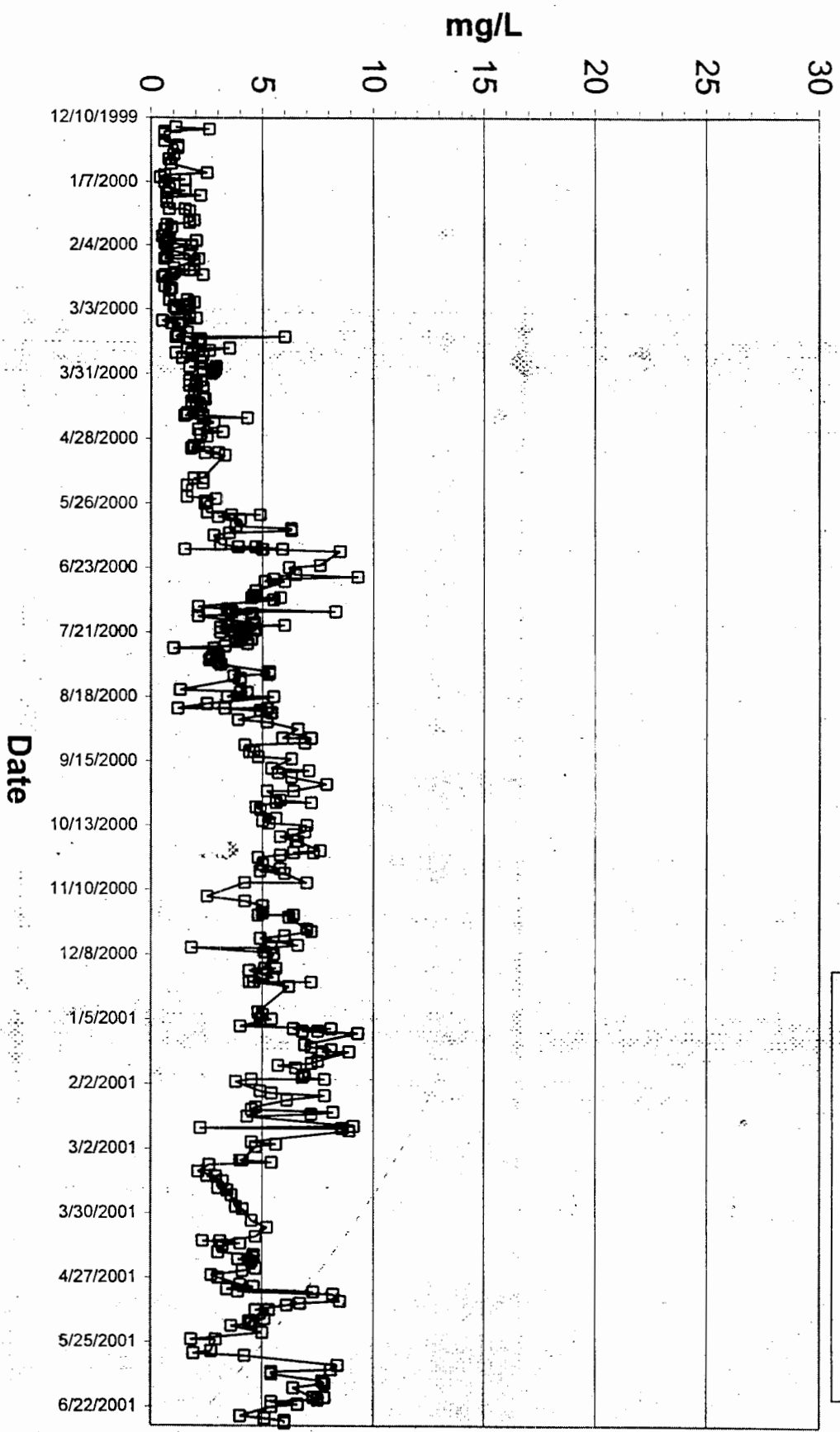

**Radioactive Liquid Waste Treatment Facility**  
**Ground Water Discharge Plan (DP-1132) Quarterly Report**  
**3rd Quarter, 2003**

**Table 2.0. RLWTF Weekly Effluent Monitoring Analytical Results, 3rd Quarter, 2003.**

<b><u>JUNE, 2002</u></b>	6/24/2003	<0.01	<0.06	109
	6/30/2003	<0.01	0.10	134
<b><u>JULY, 2003</u></b>	7/7/2003	<0.01	0.13	124
	7/15/2003	0.02J	0.15	121
	7/18/2003	0.04J	0.16	143
	7/29/2003	<0.01	0.15	183
<b><u>AUGUST, 2003</u></b>	8/5/2003	0.07	0.16	143
	8/13/2003	0.05	0.07J	75
	8/19/2003	0.18	0.12	105
	8/26/2003	0.58	0.12	81
<b><u>SEPTEMBER, 2003</u></b>	9/3/2003	0.39	0.16	150
	9/9/2003	0.36	0.10	126
	9/15/2003	0.67	0.16	129
	9/23/2003	0.70	0.16	61
<b>3rd Quarter 2003 Averages (mg/L)</b>		<b>0.22</b>	<b>0.13</b>	<b>120</b>
<i>NM WQCC 3103. Ground Water Standards (mg/L)</i>		<i>10.0<sup>4</sup></i>	<i>1.6</i>	<i>1000</i>

**Notes:**

<sup>1</sup>Results for these analyses are pending validation.

<sup>2</sup>A duplicate sample result.

<sup>4</sup>The NMWQCC Regulation 3103, Ground Water Standard is for NO3-N

All analyses by the General Engineering Laboratories, Charleston, South Carolina.

TA-50 RW Treatment Facility Ground Water Discharge Plan - Monitoring Wells



- LEGEND**
- ☒ Contour, 100 ft
  - ☒ Contour, 20 ft
  - ☒ Treatment Stream
  - ☒ Road, Paved
  - ☒ Building (0001)
  - ☒ Structure (100)
  - ☒ Wetland
  - ☒ Stream Gaging Station
  - ☒ Discharge Plan Monitoring Well
  - ☒ Other Monitoring Well

- Discharge Plan Monitoring Wells**
- MCO-3
  - MCO-4
  - MCO-4B
  - MCO-4C
  - MCO-5
  - MCO-6
  - MCO-7
  - MCO-8
- Montezuma Canyon Stream Gaging Station**
- GS-1
  - GS-2



Prepared by: [Name]  
 Date: [Date]



**ve Liquid Waste Treatment Facility  
Water Discharge Plan (DP-1132) Quarterly Report  
ter, 2003**

**Table 1.0. Mortandad Canyon Alluvial Monitoring Wells Analytical Results, 3rd Quarter, 2003.**

Well ID	Sample Date	Parameter 1	Parameter 2	Parameter 3	Parameter 4	Parameter 5	Parameter 6
MCO-3	8/11/2003	2,35J	2.81	0.34	<0.024	310	0.621
MCO-4B	8/13/2003	10.4	2.4	0.30	<0.024	400	0.865
MCO-6	8/14/2003	15.8	2.78	0.24	<0.024	415	0.940
MCO-7	8/14/2003	60.4	3.50	0.23	<0.024	342	1.21
<i>NM WQCC 3103. Ground Water Standards (mg/L)</i>			$10^2$			1000	1.6

**Notes:**

<sup>1</sup>NS means that there was not sufficient water available for sampling.

<sup>2</sup>The NMWQCC Regulation 3103. Ground Water Standard is for NO<sub>3</sub>-N.

<sup>3</sup>Nonfiltered sample.

J indicates an estimated value. The result was less than the reporting limit, but greater than the detection limit.

All analyses by General Engineering Laboratories, Charleston, SC.

All samples filtered unless otherwise noted.

# TA-50 Discharge Volumes 1963-2002

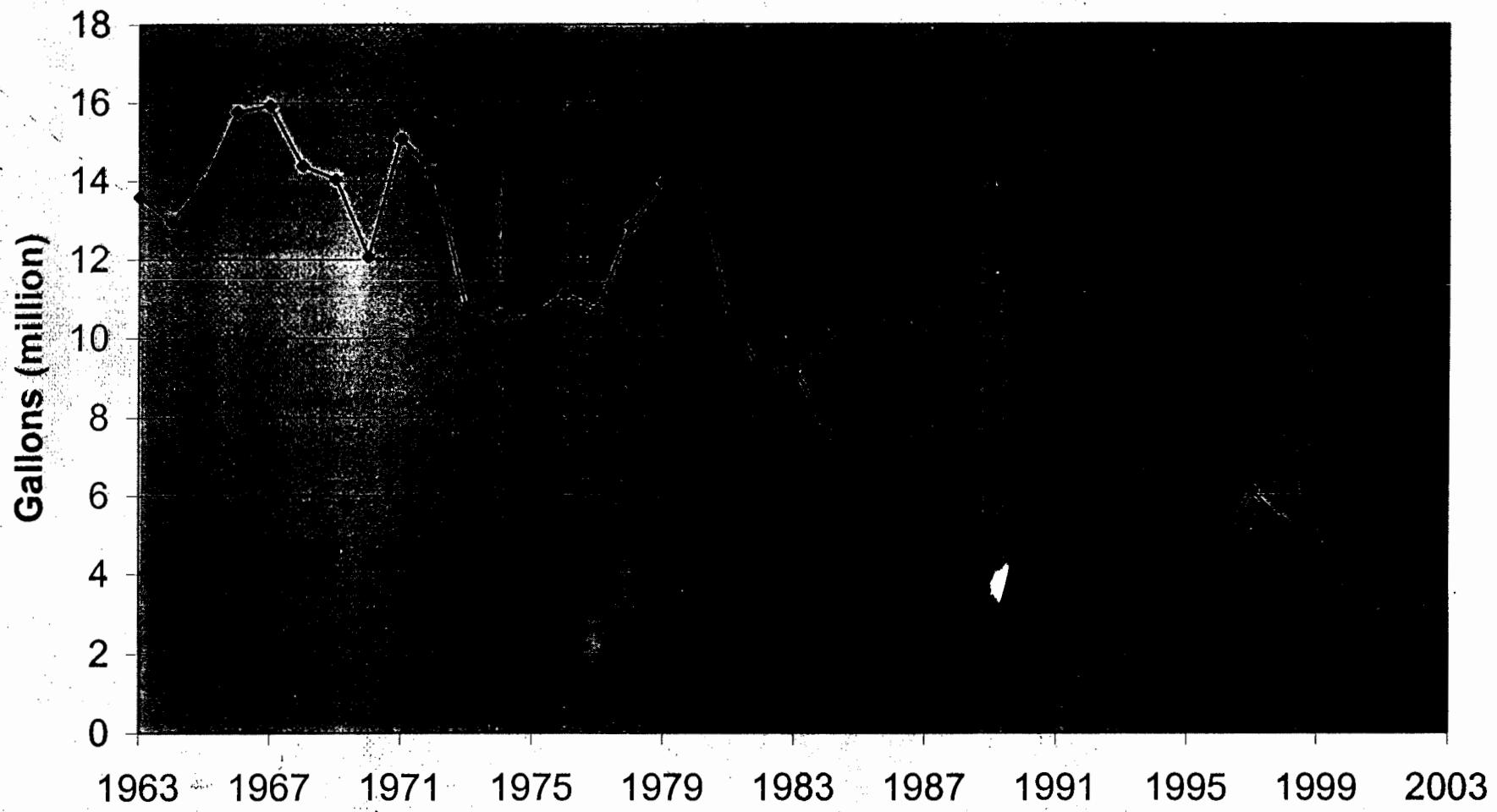

### Annual Discharge Volumes Mortandad Canyon 1964-2002

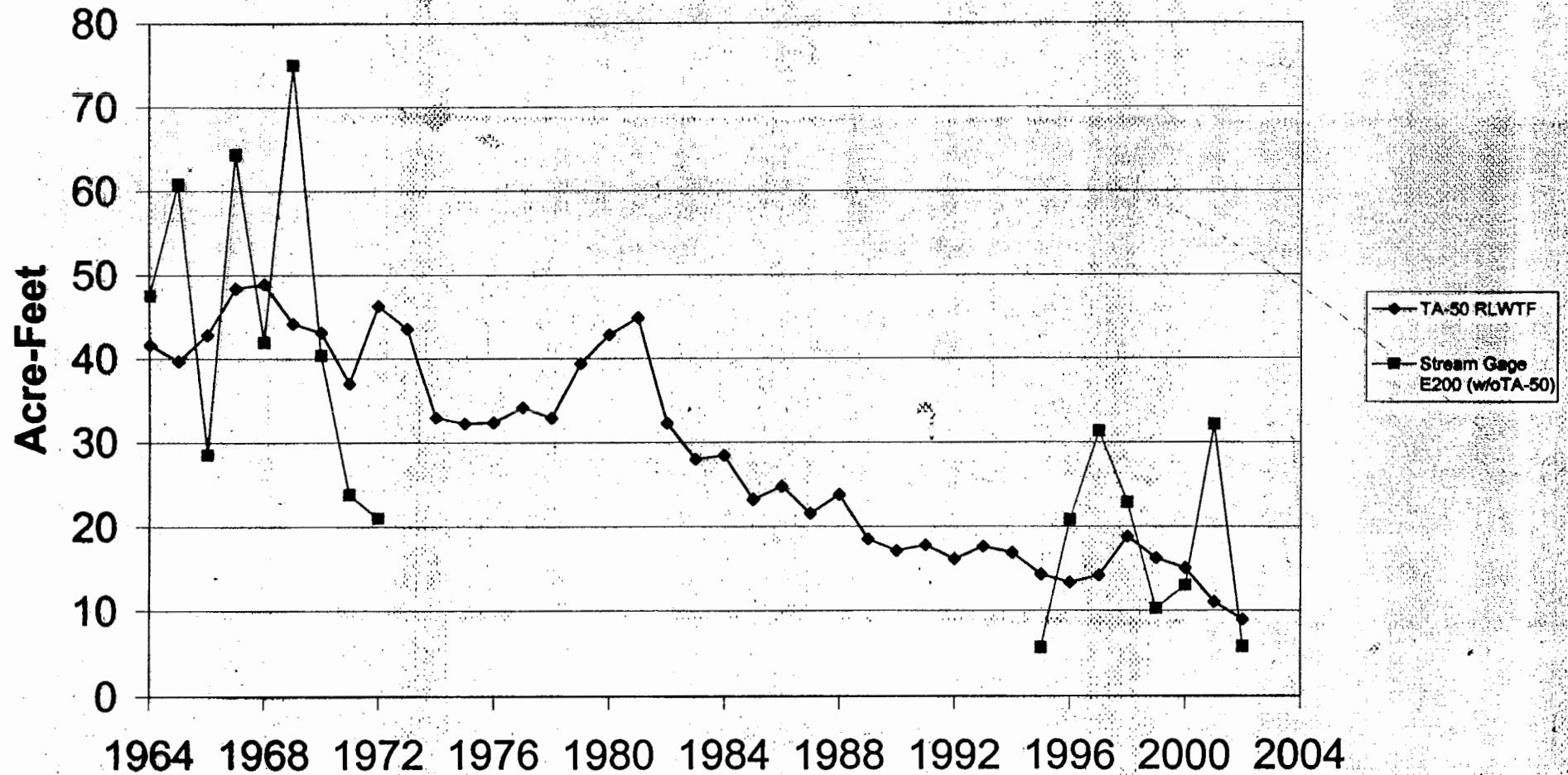



**TA-50 Portion of Annual Discharge Volumes  
Mortandad Canyon 1995-2002  
Average Ratio: 0.49**

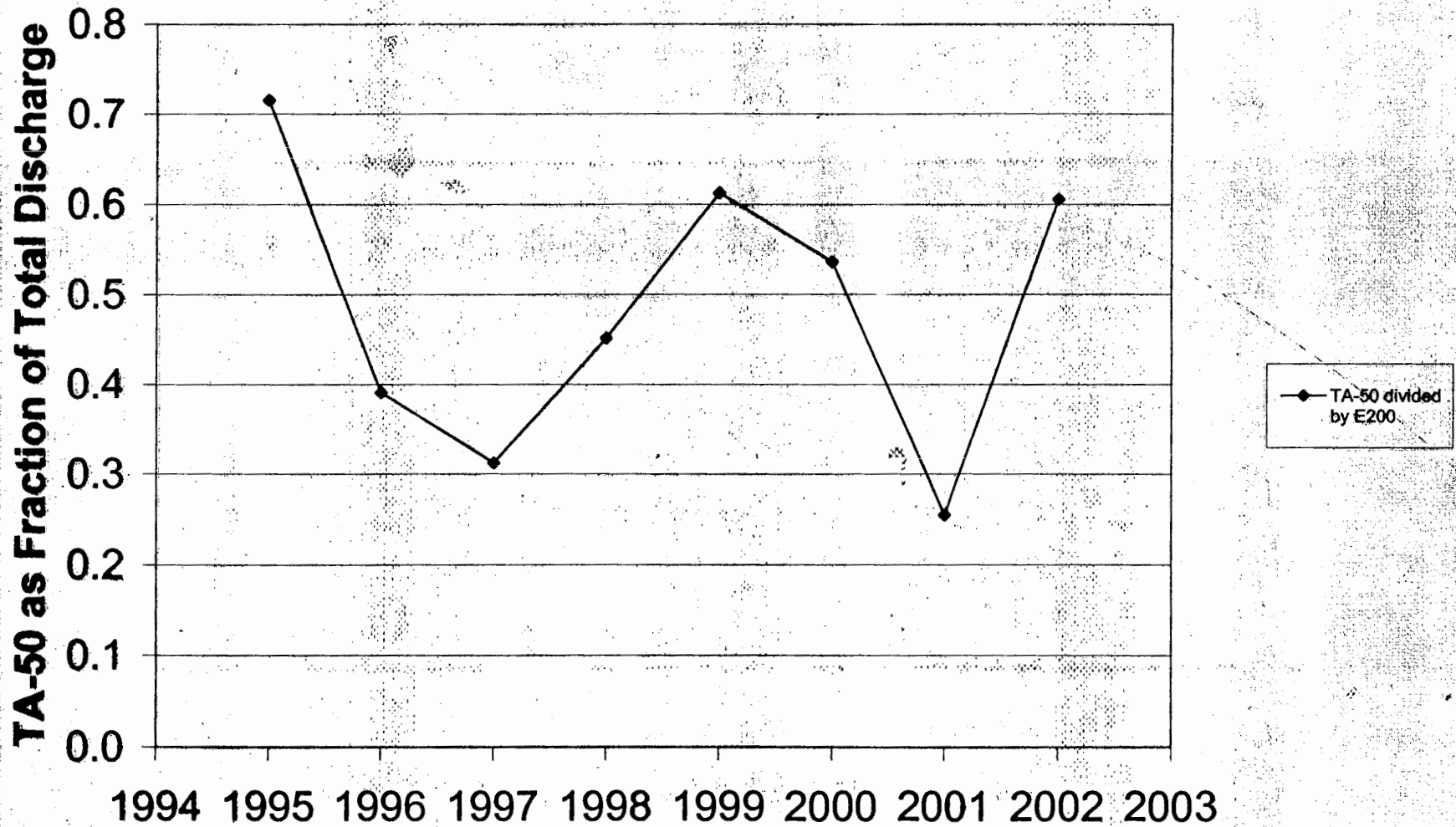



**TA-50 Portion of Annual Discharge Volumes  
Mortandad Canyon 1963-1972  
Average Ratio: 0.51**

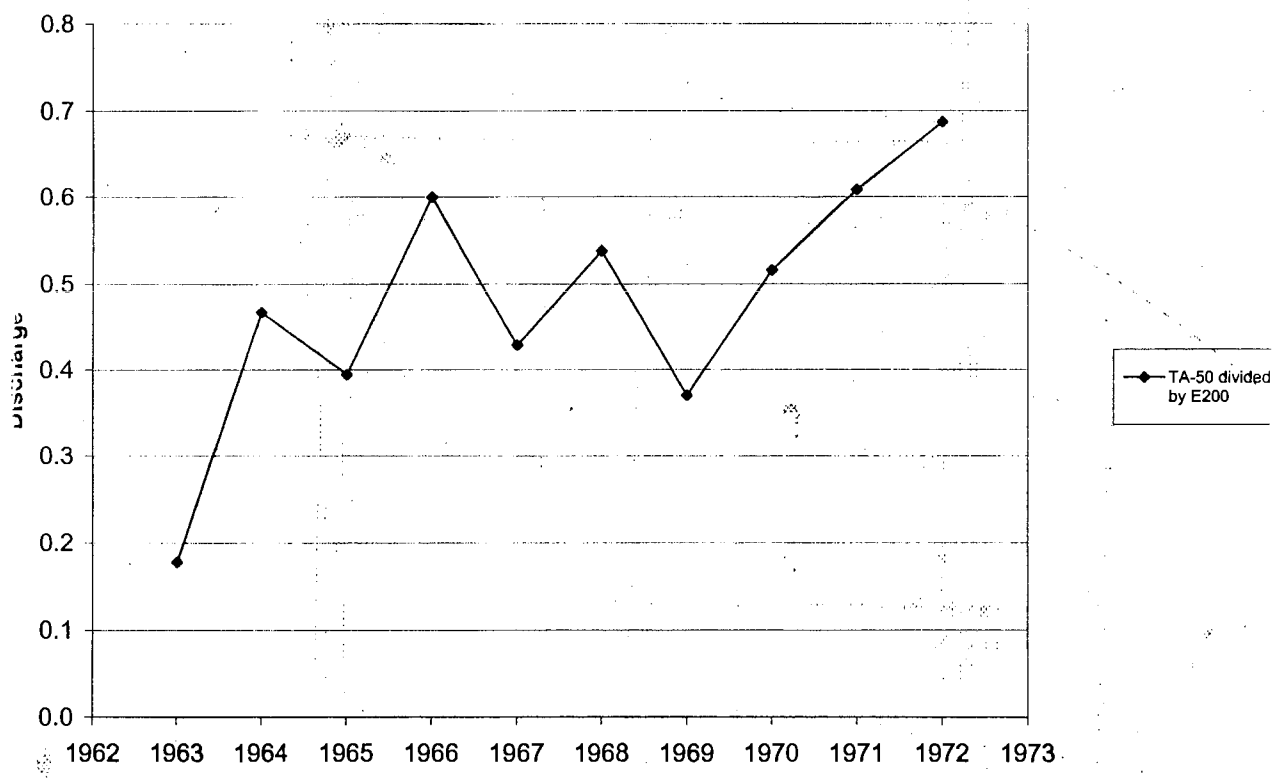

# Other Investigations

---

---

- **Infiltration Investigation:** constrain various terms of water budget to quantify deep percolation.
- **Colloid Investigation:** evaluate potential importance of colloids in the transport of adsorbed contaminants.

# Data Analysis and Interpretation

---

---

- **Guide data collection:** Real-time data analysis of characterization data for up-to-date interpretation of contaminant nature and extent.
- **Overall synthesis of data:** Numerical models of fate and transport through alluvial and vadose zone to underlying regional aquifer.

# Mortandad Canyon Groundwater Investigation

---

---

P. Longmire, K. Bitner, D. Broxton,  
D. Vaniman, T. Whitacre,  
R. Gray, & B. Robinson

Groundwater Protection Program  
Quarterly Meeting  
October 27, 2003

# Investigation Objectives

---

---

## Collect data and information to:

- Determine nature and extent of contamination
- Estimate present-day human health and ecological risk *pathway analysis*
- Base corrective action decisions for PRS aggregates and groundwater
- Make recommendations for long-term monitoring

# Surface Water Sampling

02253

1. Mortandad Canyon - east of Diamond Dr.
2. wetland near NPDES outfall at TA-3
3. Effluent Canyon wetland near head of canyon
4. wetland at TA-55
5. Effluent Canyon - 300 ft east of TA-50 discharge
6. Down stream of Effluent & Mort.
7. Ten site canyon east of TA-35

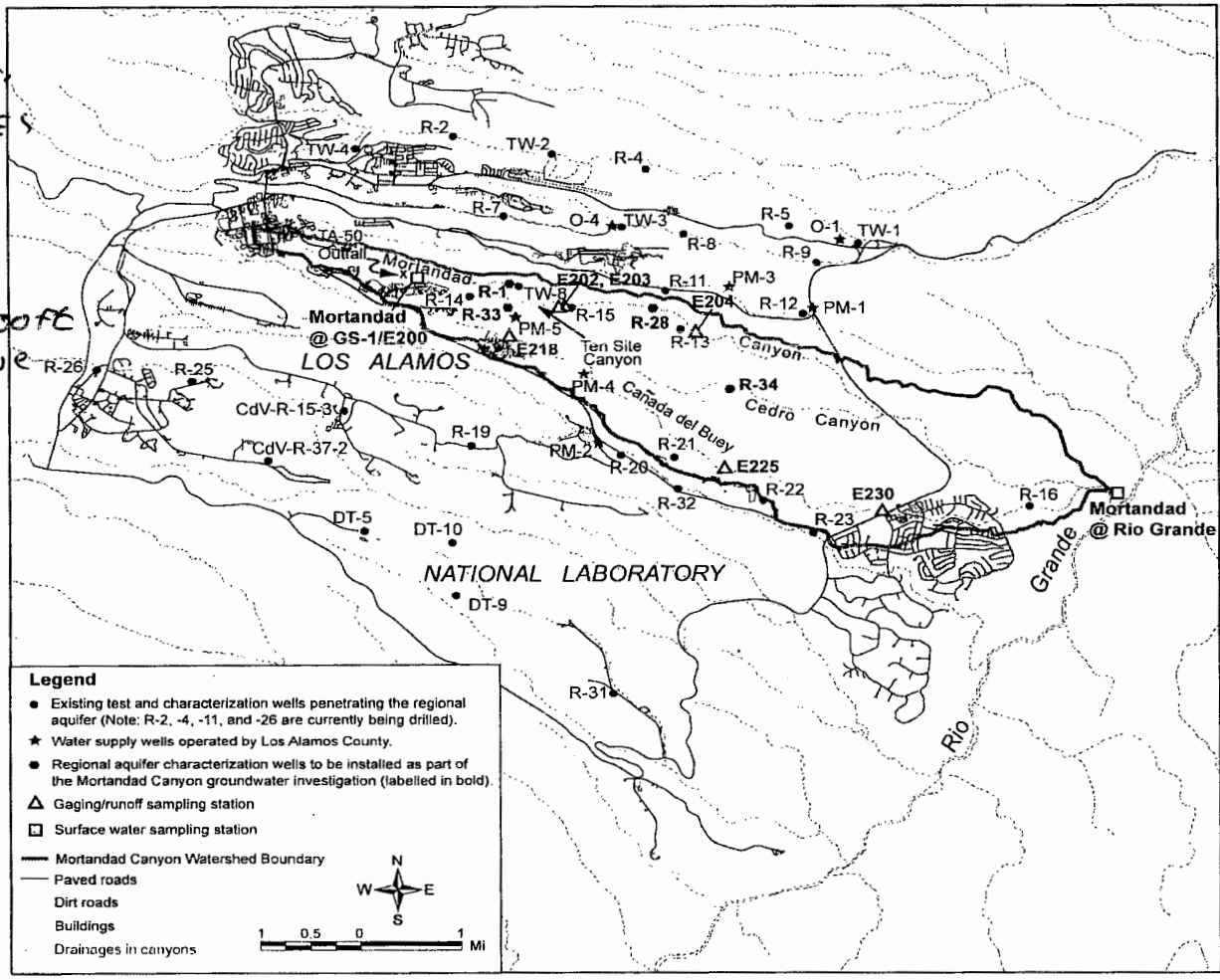

UNCLASSIFIED



# Piezometers, Wells, & Boreholes

: 0225H

Mortandad Canyon East

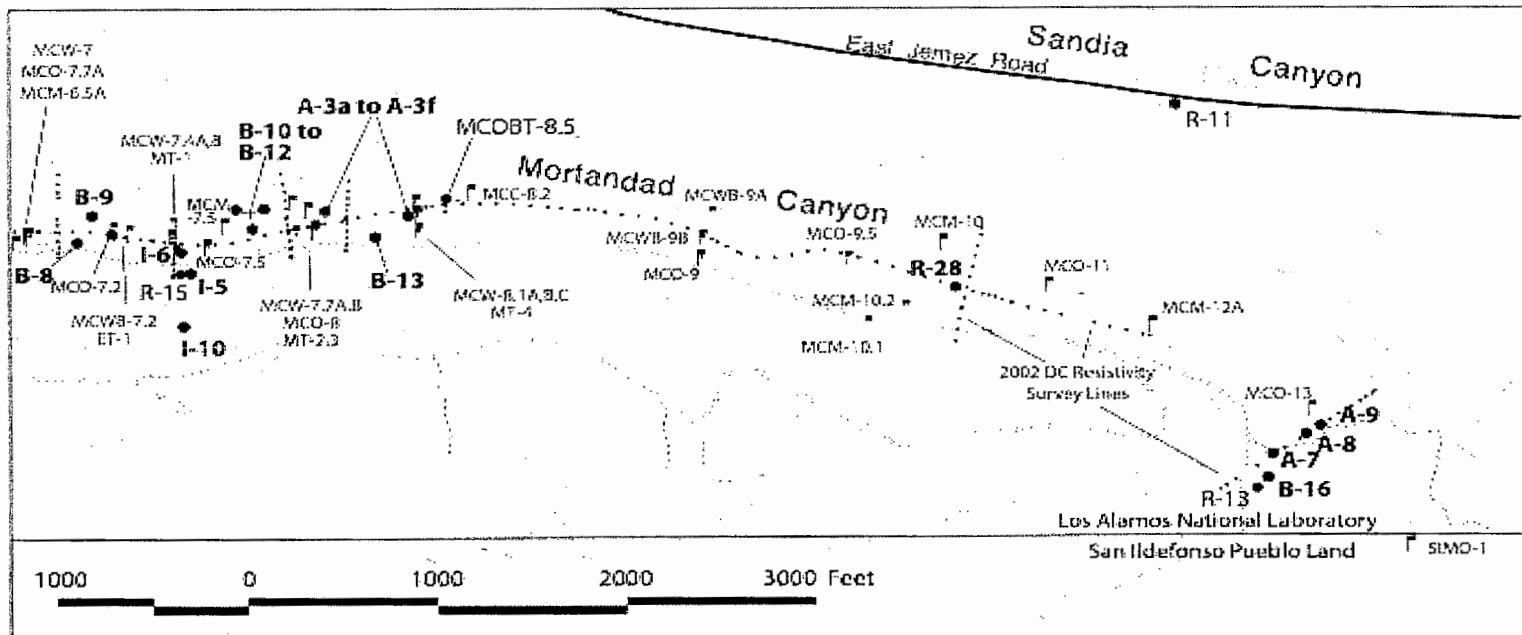

- Proposed wells under this workplan addendum. Note: R-11 is currently being installed under the Hydrogeologic Workplan.
- Wells installed since 1997 (as part of Mortandad Canyon Work Plan)
- ▭ Wells installed before 1997 (prior to Mortandad Canyon Work Plan)
- Buildings
- Topographic Contours: interval = 20 ft
- Paved road
- - - Dirt road



UNCLASSIFIED

Los Alamos



# Piezometers, Wells & Boreholes

02255

Mortandad Canyon West

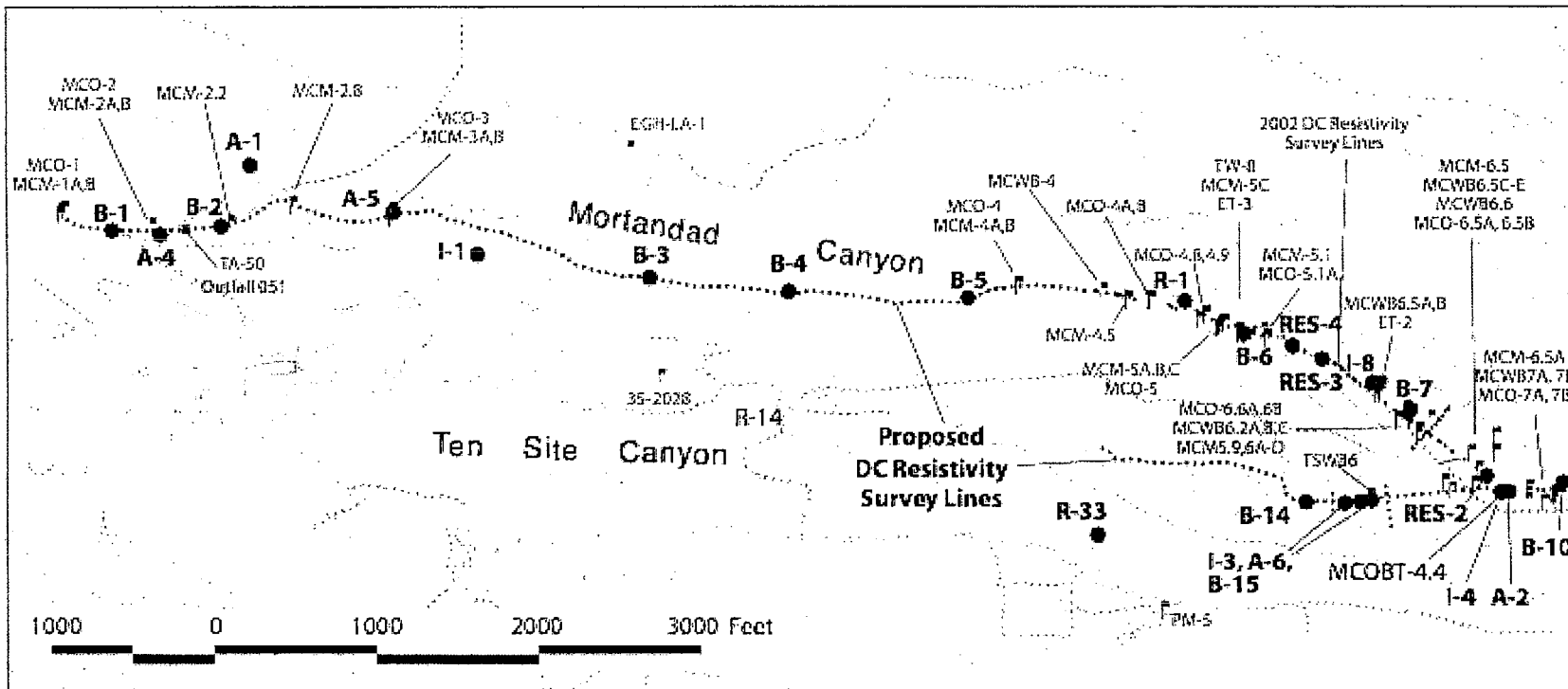

UNCLASSIFIED



# Geophysical Surveys and Boreholes

: 02256

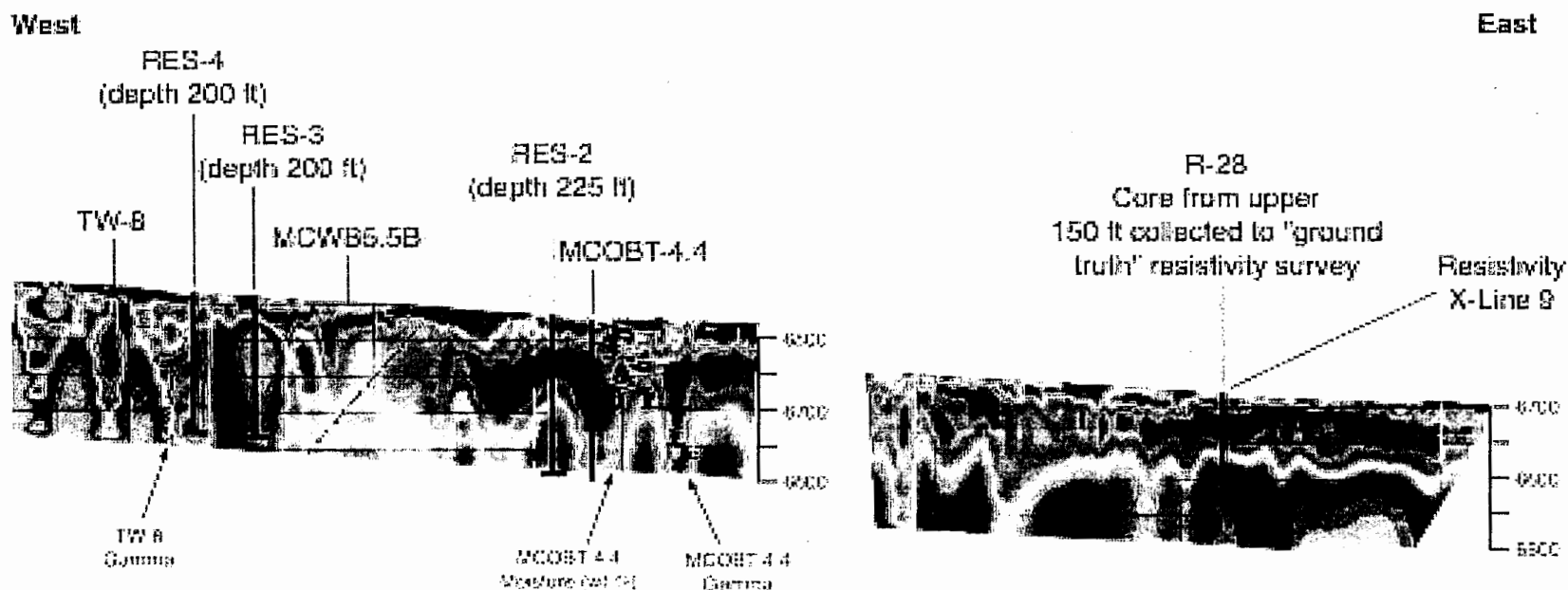

Colored profiles represent modeled DC resistivity values. The colored scale is nonlinear with cool colors (blue) representing conductive zones of 0 to  $\sim 150$  Ohm-m, intermediate colors (yellow) representing zones of  $\sim 600$  to  $700$  Ohm-m, and warm colors (red) representing resistive zones of  $2000$  to  $>6400$  Ohm-m.

# Scope of Field Work Summary

---

---

- Surface Water Sampling: 7 locations
- Piezometers: 6 locations
- Alluvial Wells: 9 locations
- Shallow Boreholes: 16 locations
- Intermediate Wells: 7 locations
- Regional Aquifer Wells: 4 locations
- Geophysical Surveys and Boreholes

# Present-Day Risk to Human Health and Ecological Receptors

---

---

- **Surface water:** sampling 7 areas of persistent water,  $\bar{X}_2$  sampling events.
- **R-28:** point between R-15 (contaminants present) and R-13 (contaminants absent).
- **R-33:** sentry well for PM-5.
- **Geomorphic surveys:** conducted under RFI Work Plan for Mortandad Canyon.

# Location of Contaminants and Extent of Impact on Regional Aquifer

---

---

## 4 regional aquifer wells:

- R-1 (TW-8 replacement): where canyon widens.
- R-28: point between R-15 (contaminants present) and R-13 (contaminants absent).
- R-33: sentry well for PM-5.
- R-34: San Ildefonso Pueblo monitoring point.

# Perched Zones and Role in Contaminant Transport

---

---

- Geophysical surveys and boreholes to identify potential perched water in Bandelier Tuff (done first).
- 7 intermediate wells: collect core and borehole and well water samples; possible hydrologic testing.
- 4 regional aquifer wells: identify the presence of intermediate zones encountered and collect boreholes water samples.

# Extent and Depth of Contaminant Fronts

---

---

Core and/or water samples to measure moisture, anions, stable isotopes, & contaminants from:

- 9 alluvial wells
- 16 shallow (<100 ft) boreholes
- 7 intermediate wells
- 4 regional aquifer wells

# Location and Rate of Water Infiltration

---

---

02262

- **Infiltration investigation:** Location and rate of surface water infiltrating into the subsurface.
- **Piezometers:** 6 to determine alluvial groundwater movement east of sediment traps.
- **Boreholes:** 16 shallow boreholes, core samples to measure moisture, anions, stable isotopes, contaminants.
- **Alluvial Wells:** 9 wells to augment contaminant distribution information.
- **Geophysical Surveys:** DC resistivity to identify potential zones of infiltration.



# Conceptual Model Uncertainties

---

---

- Location and rate of water infiltration
- Extent and depth of strongly adsorbing, moderately adsorbing, and non-adsorbing contaminant fronts
- Presence of perched zones and role in contaminant transport
- Location of contaminants and extent of impact on regional aquifer
- Present-day risk to human health and ecological receptors

# Hydrogeologic and Contaminant Conceptual Model

192261

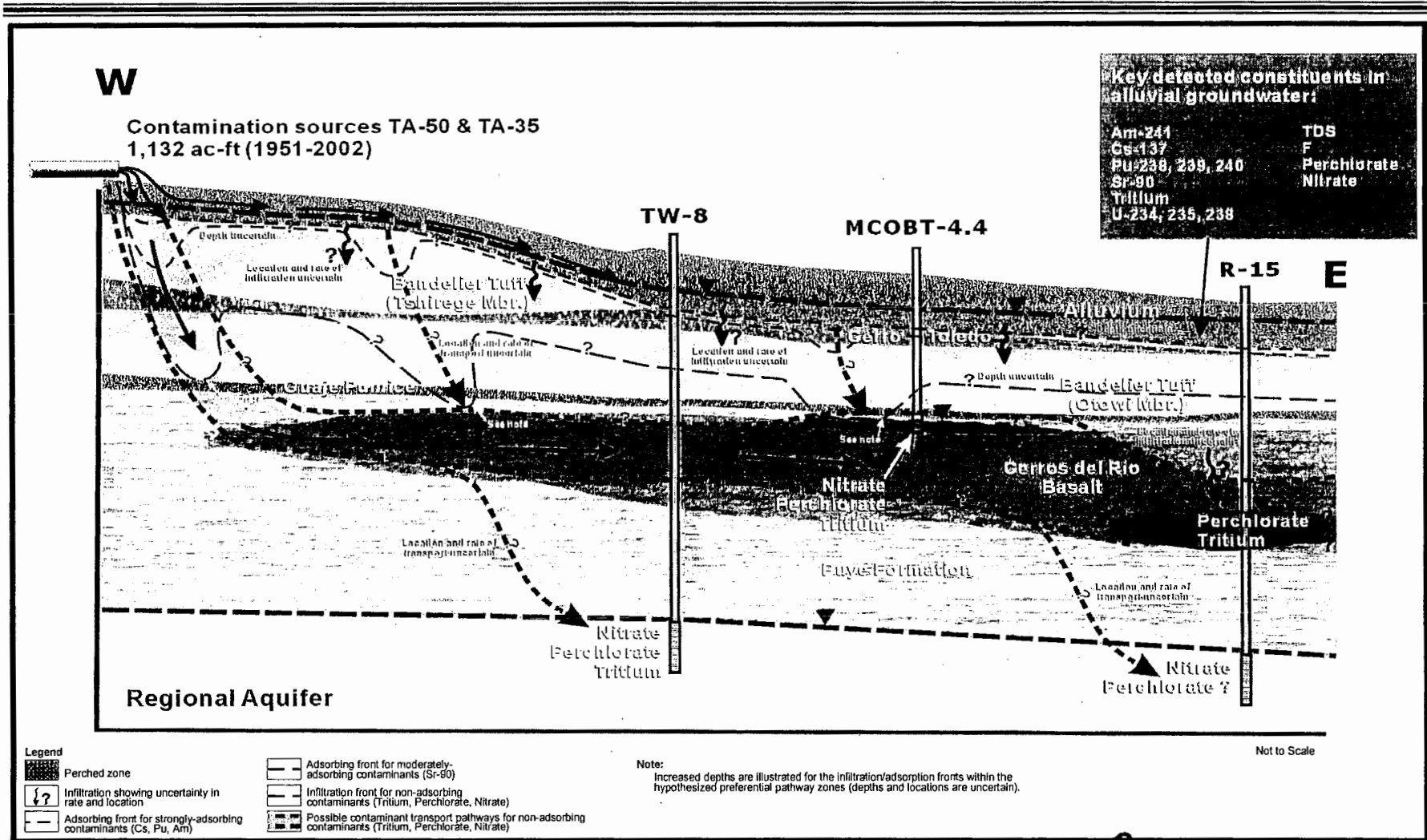

UNCLASSIFIED



# Conceptual Model Uncertainties

---

---

- Location and rate of water infiltration
- Extent and depth of strongly adsorbing, moderately adsorbing, and non-adsorbing contaminant fronts
- Presence of perched zones and role in contaminant transport
- Location of contaminants and extent of impact on regional aquifer
- Present-day risk to human health and ecological receptors

# Hydrogeologic and Contaminant Conceptual Model

02255

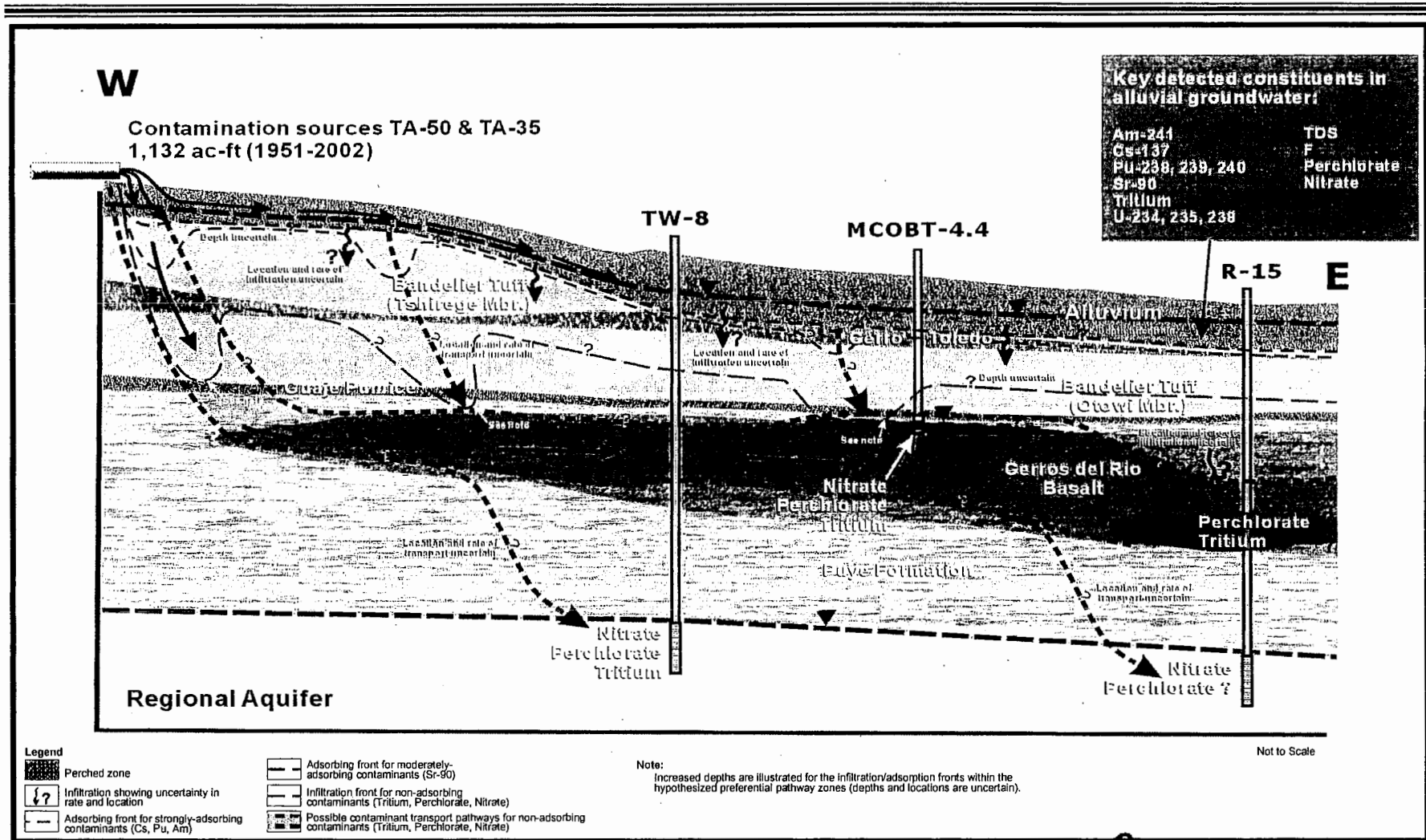

# Proposed Schedule

---

---

- **Drilling and Field Activities**
  - o Oct 2003 - December 2004
- **Sample Collection and Analysis**
  - o July 2004 - July 2005
- **Report Preparation**
  - o July 2005 - December 2005
- **Report Submittal:**
  - o December 31, 2005



# Other Investigations

---

---

- **Infiltration Investigation:** constrain various terms of water budget to quantify deep percolation.
- **Colloid Investigation:** evaluate potential importance of colloids in the transport of adsorbed contaminants.

# Data Analysis and Interpretation

---

---

- **Guide data collection:** Real-time data analysis of characterization data for up-to-date interpretation of contaminant nature and extent.
- **Overall synthesis of data:** Numerical models of fate and transport through alluvial and vadose zone to underlying regional aquifer.



# Mortandad Canyon Groundwater Investigation

---

---

P. Longmire, K. Bitner, D. Broxton,  
D. Vaniman, T. Whitacre,  
R. Gray, & B. Robinson

Groundwater Protection Program  
Quarterly Meeting  
October 27, 2003

# Investigation Objectives

---

---

Collect data and information to:

- Determine nature and extent of contamination
- Estimate present-day human health and ecological risk *pathway analysis*
- Base corrective action decisions for PRS aggregates and groundwater
- Make recommendations for long-term monitoring

# Surface Water Sampling

02273

- 1 Mortandad Canyon - east of Diamond Dr.
- 2 wetland near NPDES outfall at TA-3
- 3 Effluent Canyon wetland near head of canyon
- 4 wetland at TA-55
- 5 Effluent Canyon - 300 ft east of TA-50 discharge
- 6 Down stream of Effluent & Mort.
- 7 Ten site canyon east of TA-35

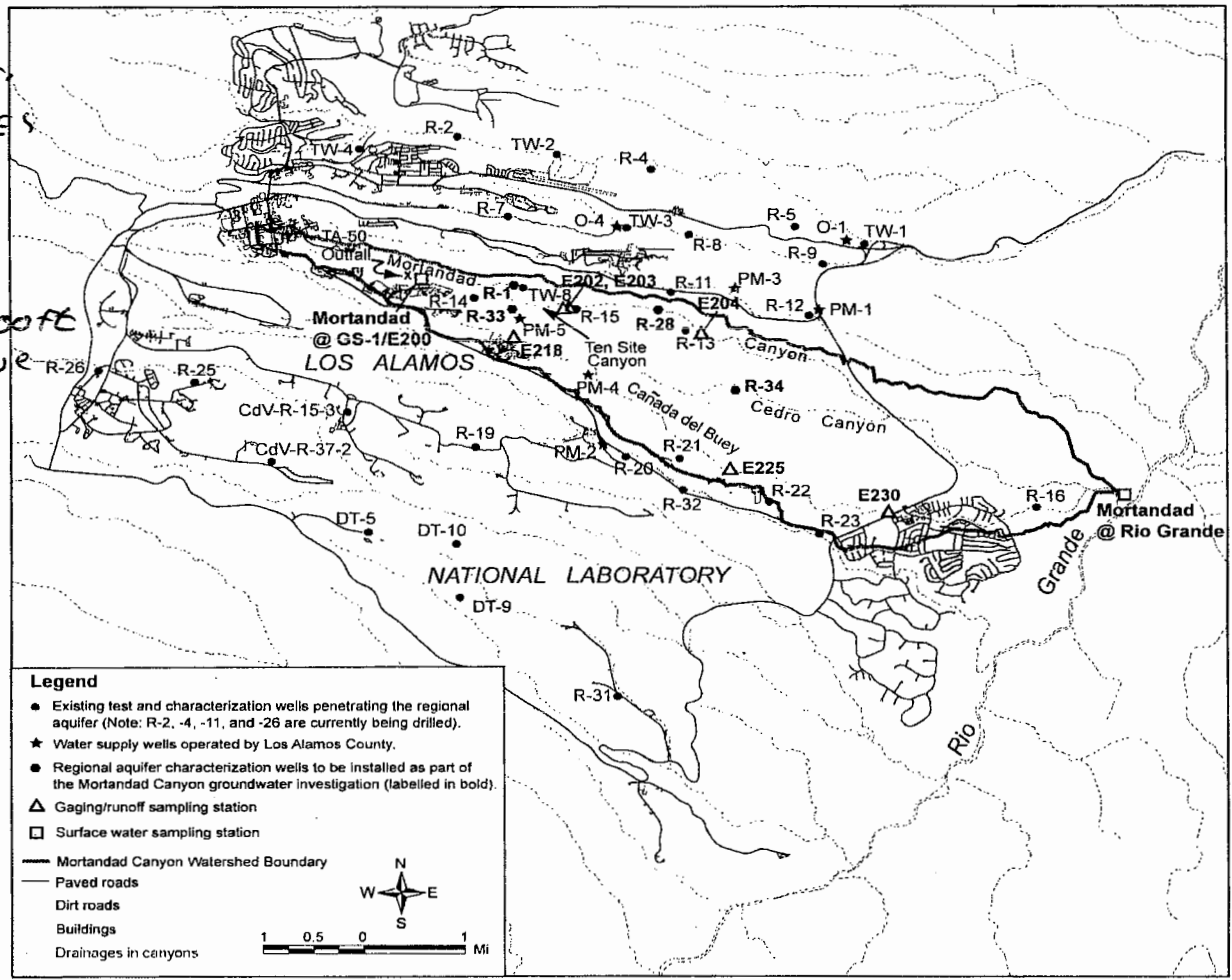

UNCLASSIFIED



# Piezometers, Wells, & Boreholes

022714

Mortandad Canyon East

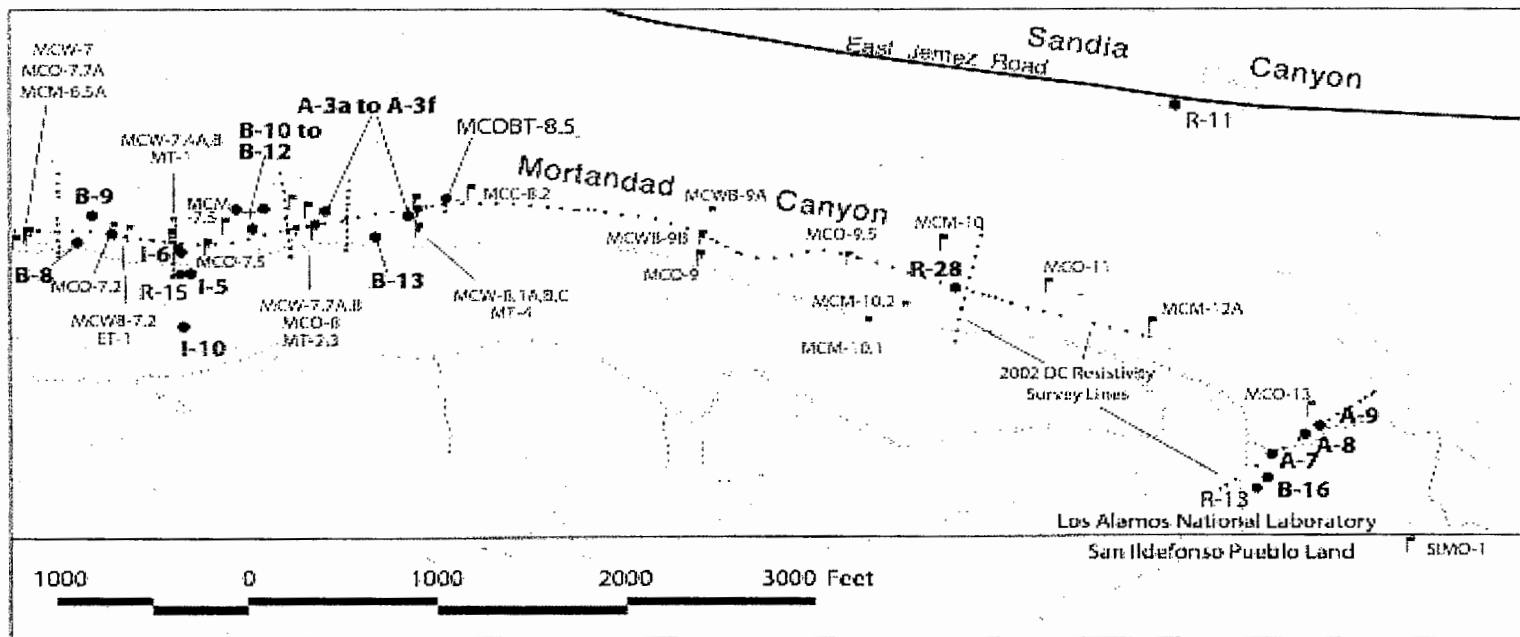

- Proposed wells under this workplan addendum. Note: R-11 is currently being installed under the Hydrogeologic Workplan.
- Wells installed since 1997 (as part of Mortandad Canyon Work Plan)
- ▬ Wells installed before 1997 (prior to Mortandad Canyon Work Plan)
- Buildings
- Topographic contours: interval = 20 ft
- Paved road
- - - Dirt road



UNCLASSIFIED



# Piezometers, Wells & Boreholes

02275

Mortandad Canyon West

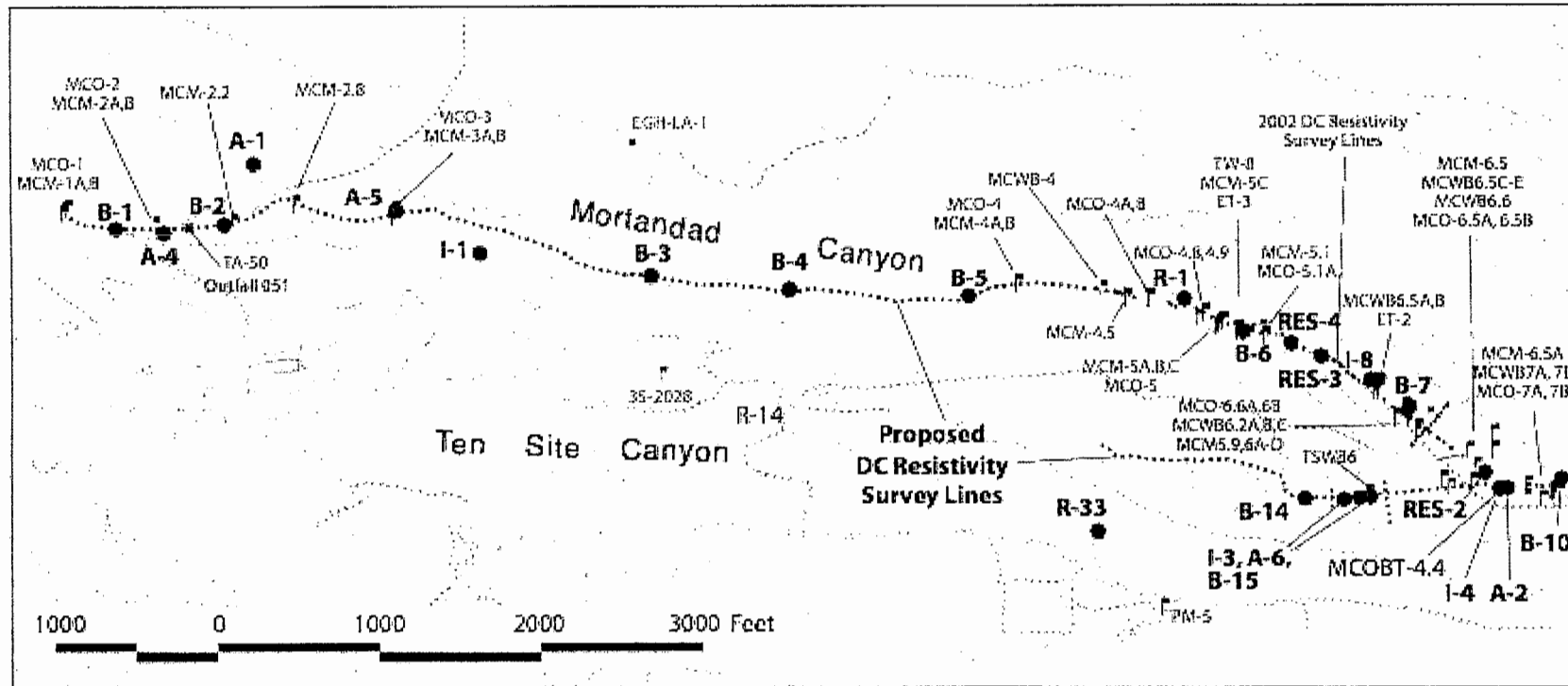

UNCLASSIFIED



# Geophysical Surveys and Boreholes

92276

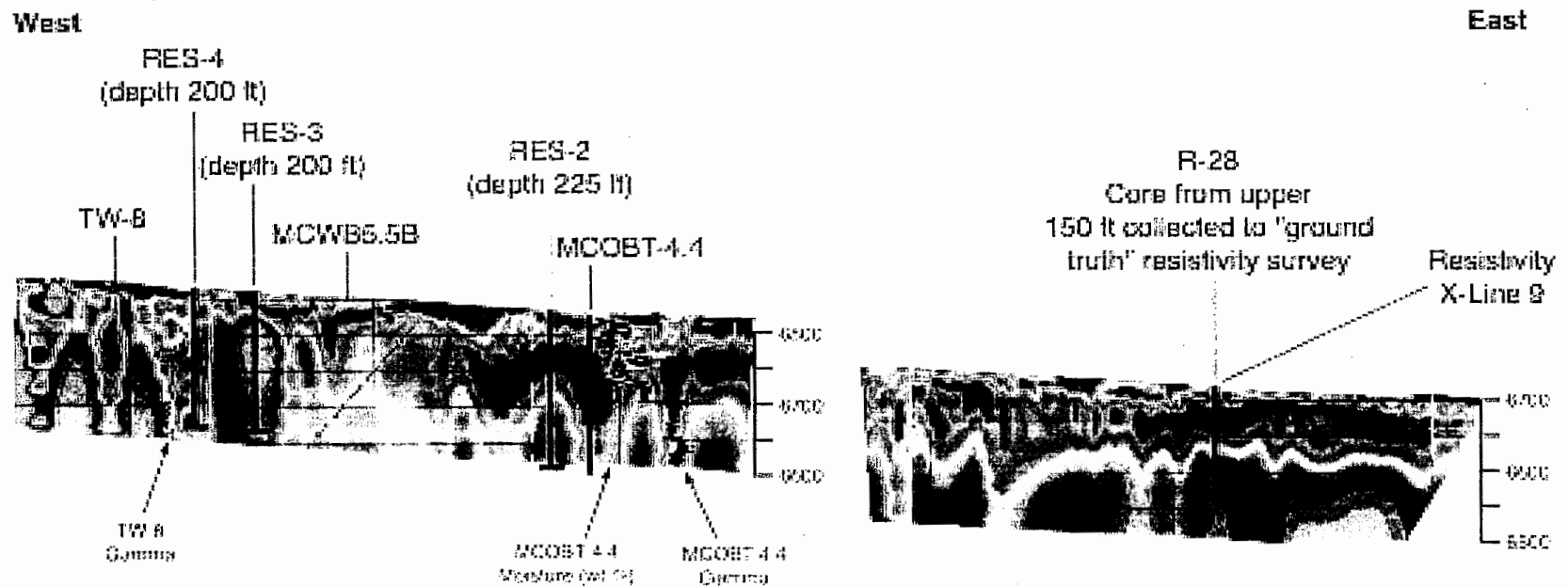

Colored profiles represent modeled DC resistivity values. The colored scale is nonlinear with cool colors (blue) representing conductive zones of 0 to  $\sim 150$  Ohm-m, intermediate colors (yellow) representing zones of  $\sim 600$  to  $700$  Ohm-m, and warm colors (red) representing resistive zones of  $2000$  to  $>6400$  Ohm-m.

# Scope of Field Work Summary

---

---

- Surface Water Sampling: 7 locations
- Piezometers: 6 locations
- Alluvial Wells: 9 locations
- Shallow Boreholes: 16 locations
- Intermediate Wells: 7 locations
- Regional Aquifer Wells: 4 locations
- Geophysical Surveys and Boreholes

# Present-Day Risk to Human Health and Ecological Receptors

---

---

- **Surface water:** sampling 7 areas of persistent water,  $\bar{x}$ <sub>2</sub> sampling events.
- **R-28:** point between R-15 (contaminants present) and R-13 (contaminants absent).
- **R-33:** sentry well for PM-5.
- **Geomorphic surveys:** conducted under RFI Work Plan for Mortandad Canyon.



# Location of Contaminants and Extent of Impact on Regional Aquifer

---

---

## 4 regional aquifer wells:

- R-1 (TW-8 replacement): where canyon widens.
- R-28: point between R-15 (contaminants present) and R-13 (contaminants absent).
- R-33: sentry well for PM-5.
- R-34: San Ildefonso Pueblo monitoring point.

# Perched Zones and Role in Contaminant Transport

---

---

- Geophysical surveys and boreholes to identify potential perched water in Bandelier Tuff (done first).
- 7 intermediate wells: collect core and borehole and well water samples; possible hydrologic testing.
- 4 regional aquifer wells: identify the presence of intermediate zones encountered and collect boreholes water samples.

# Extent and Depth of Contaminant Fronts

---

---

Core and/or water samples to measure moisture, anions, stable isotopes, & contaminants from:

- 9 alluvial wells
- 16 shallow (<100 ft) boreholes
- 7 intermediate wells
- 4 regional aquifer wells

# Location and Rate of Water Infiltration

---

---

- **Infiltration investigation:** Location and rate of surface water infiltrating into the subsurface.
- **Piezometers:** 6 to determine alluvial groundwater movement east of sediment traps.
- **Boreholes:** 16 shallow boreholes, core samples to measure moisture, anions, stable isotopes, contaminants.
- **Alluvial Wells:** 9 wells to augment contaminant distribution information.
- **Geophysical Surveys:** DC resistivity to identify potential zones of infiltration.

## TA-50 RLWTF DISCHARGE PLAN HISTORY

- Apr-96 NMED Request for Discharge Plan
- Aug-96 Discharge Plan Submitted
- Nov-96 Public Notice Issued
- Apr-97 to Sep-98 Requests/Replies for Additional Info
- Sep-98 NMED Letter of Non-Compliance
- Feb-99 Request/Reply for Additional Info
- Mar-99 Nitrate Moratorium Implemented

# TA-50 RLWTF DISCHARGE PLAN HISTORY

Nitrate-Nitrogen in RLWTF Effluent January 1999 through July 2003

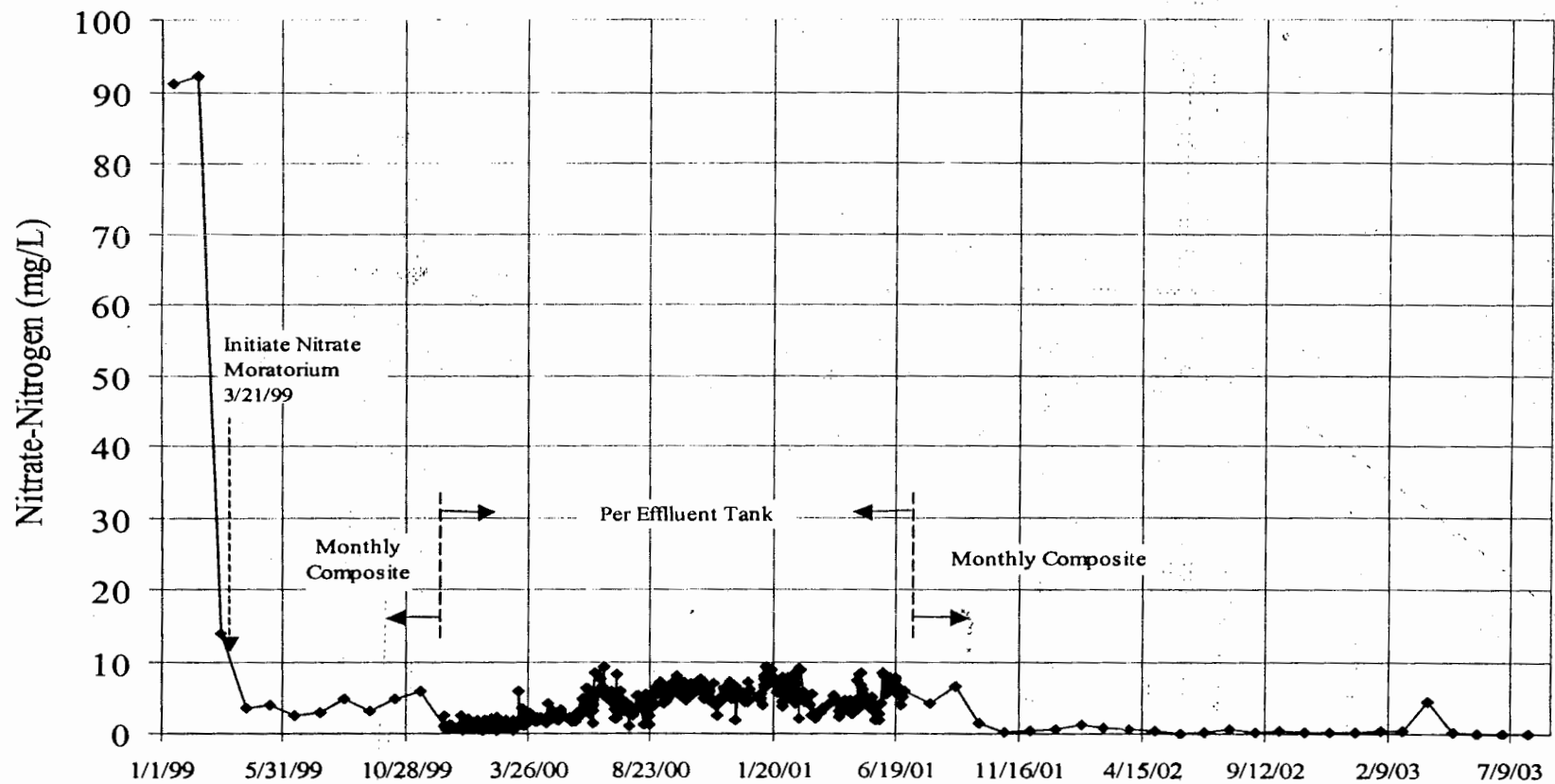

# TA-50 RLWTF DISCHARGE PLAN HISTORY

02285

➤ March 21, 1999

Effluent Meets WQCC Standards

➤ Apr-99

Phase I—TUF and RO Start-Up

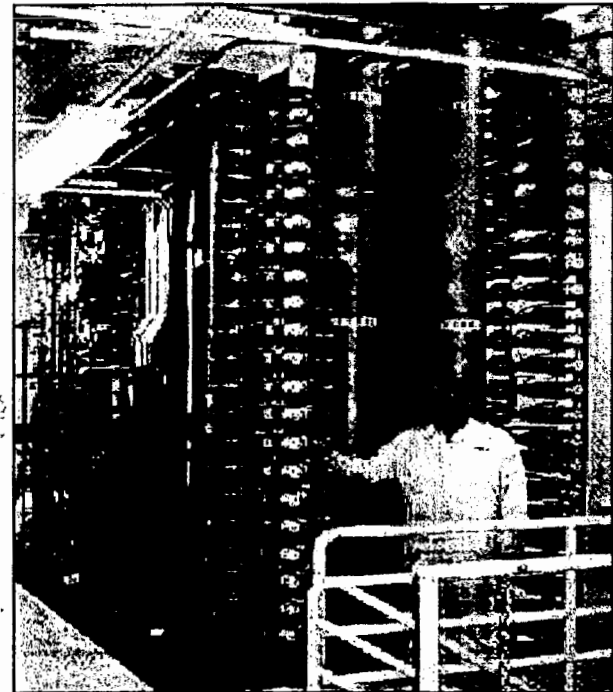
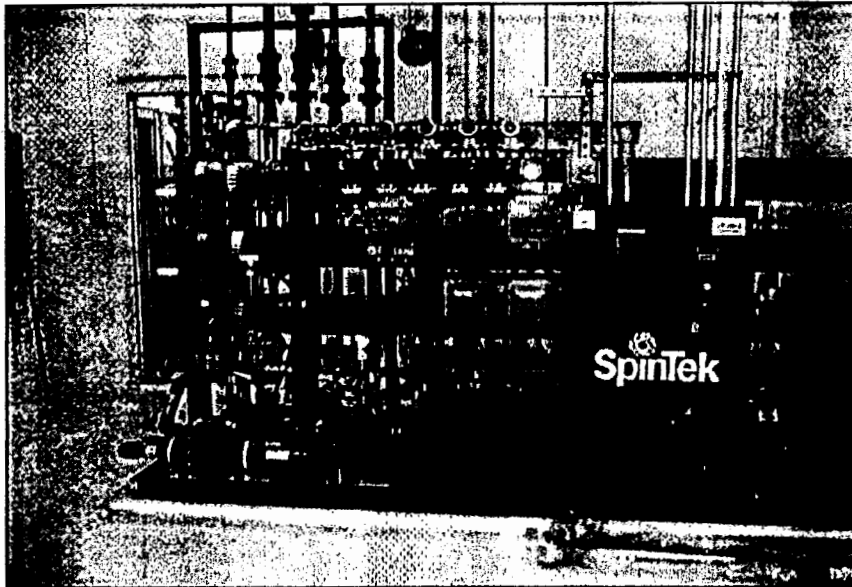

# TA-50 RLWTF DISCHARGE PLAN HISTORY

- May-99 Voluntary Qtrly Reporting by LANL
- Jan-00 Phase II—EDR Start-Up
- Jan-00 Phase II—Evaporator Start-Up

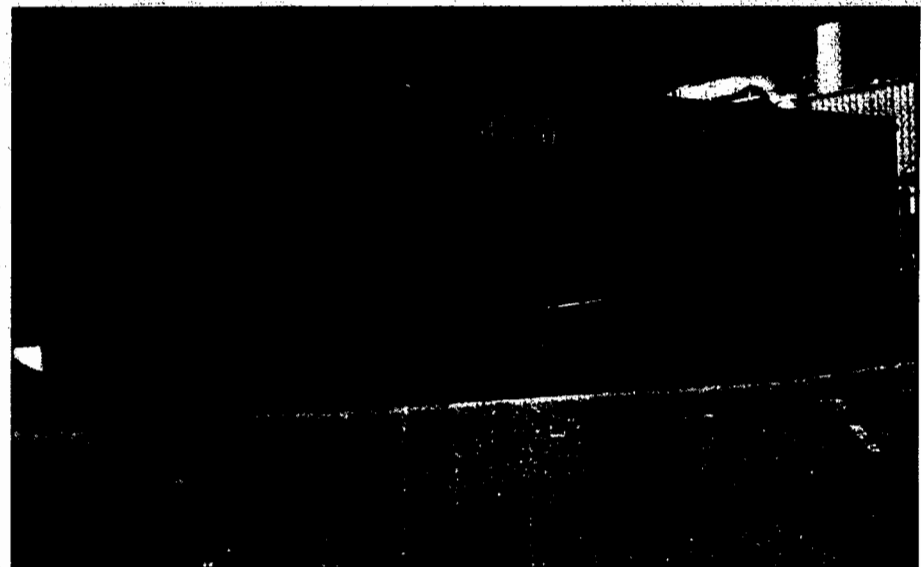



# TA-50 RLWTF DISCHARGE PLAN HISTORY

➤ Jan-02

Request/Reply for Additional Info

➤ Aug-03

NMED Reissues Public Notice

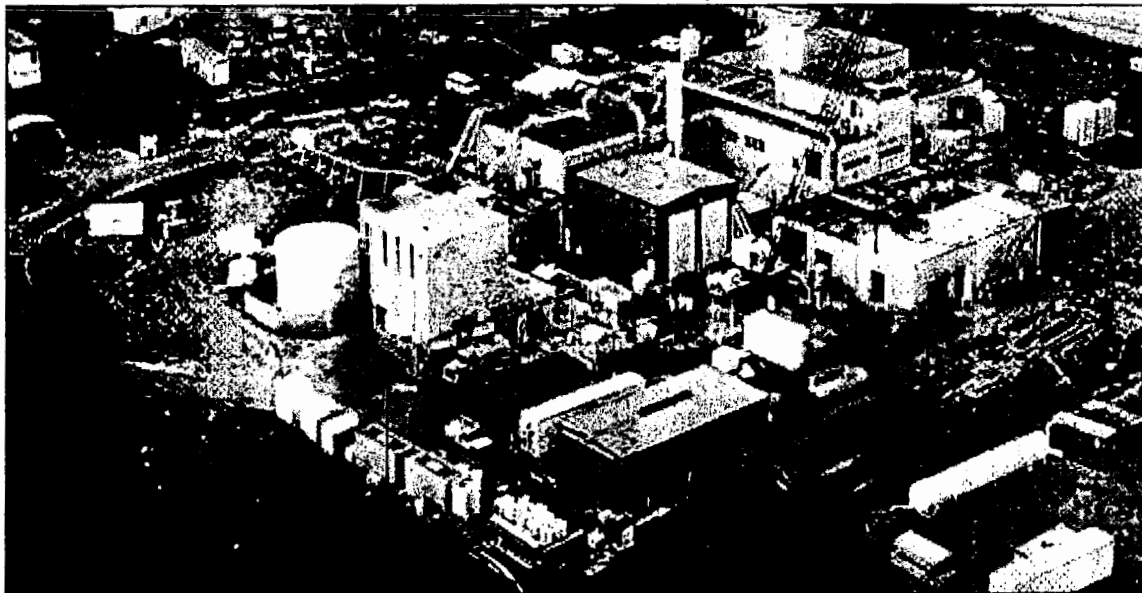

# TA-50 RLWTF DISCHARGE PLAN HISTORY

## Related Milestones

➤ Dec-99 to present

RLWTF Meets DOE DCGs

➤ Oct-00

Tritium Reductions in Effluent

➤ Mar-02

IX Treatment for ClO<sub>4</sub> Removal

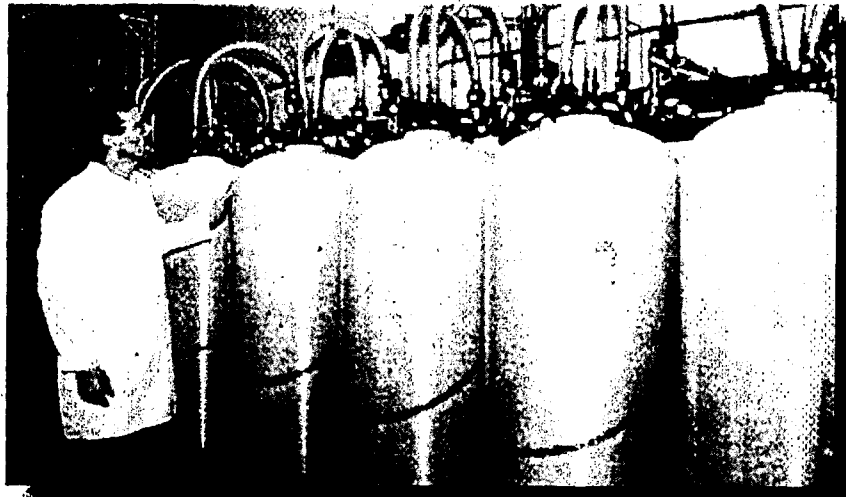

# Radioactive Material—Reduction in RLWTF Effluent

Monthly and 12 Month Running Average of RLWTF Effluent from December 1998 through June 2003 (55 months) Analysis of Flow Weighted Monthly Composite Samples

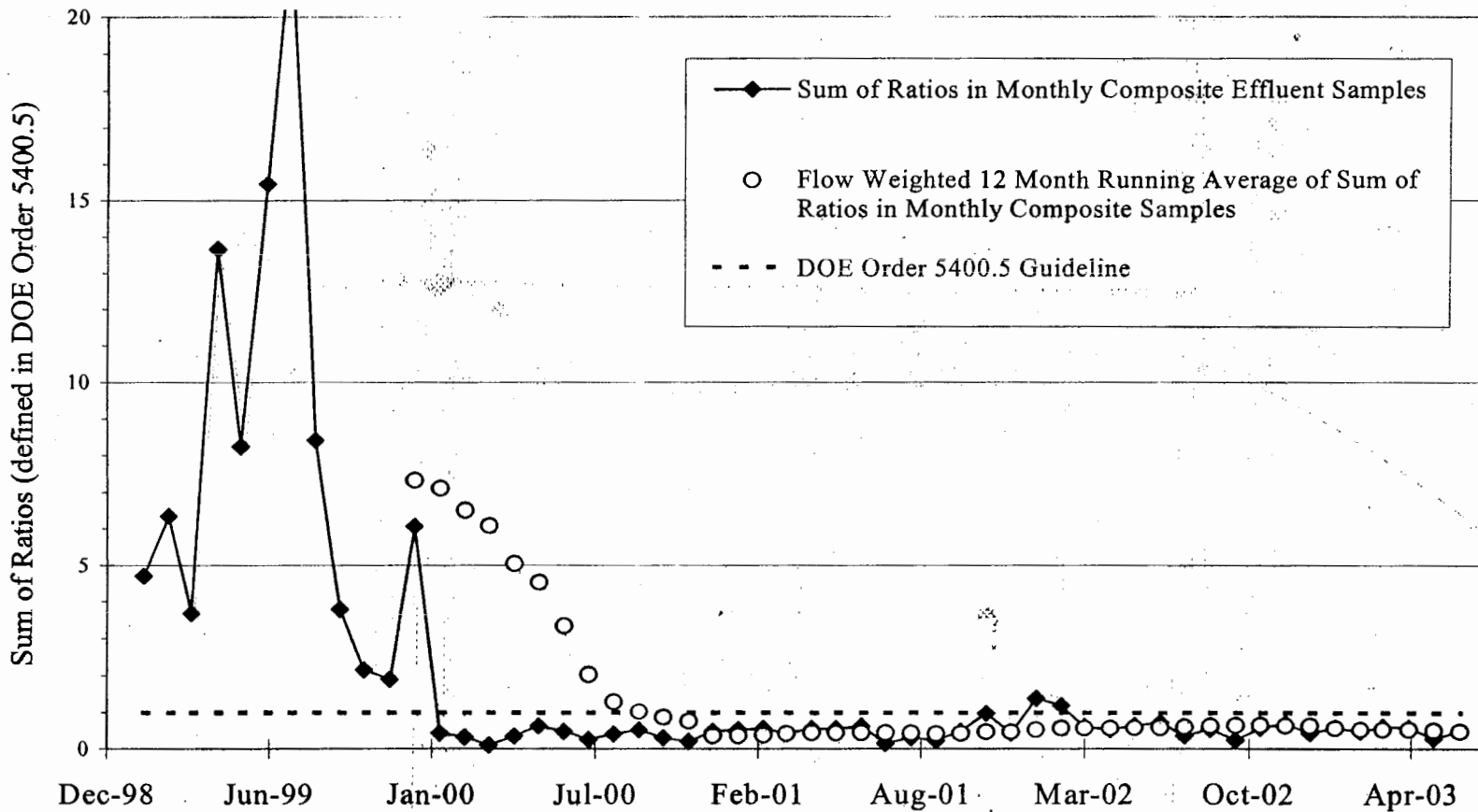

# Tritium—Reduction in RLWTF Effluent

Tritium in Final Monthly Composite Samples (1/99 - 7/03)

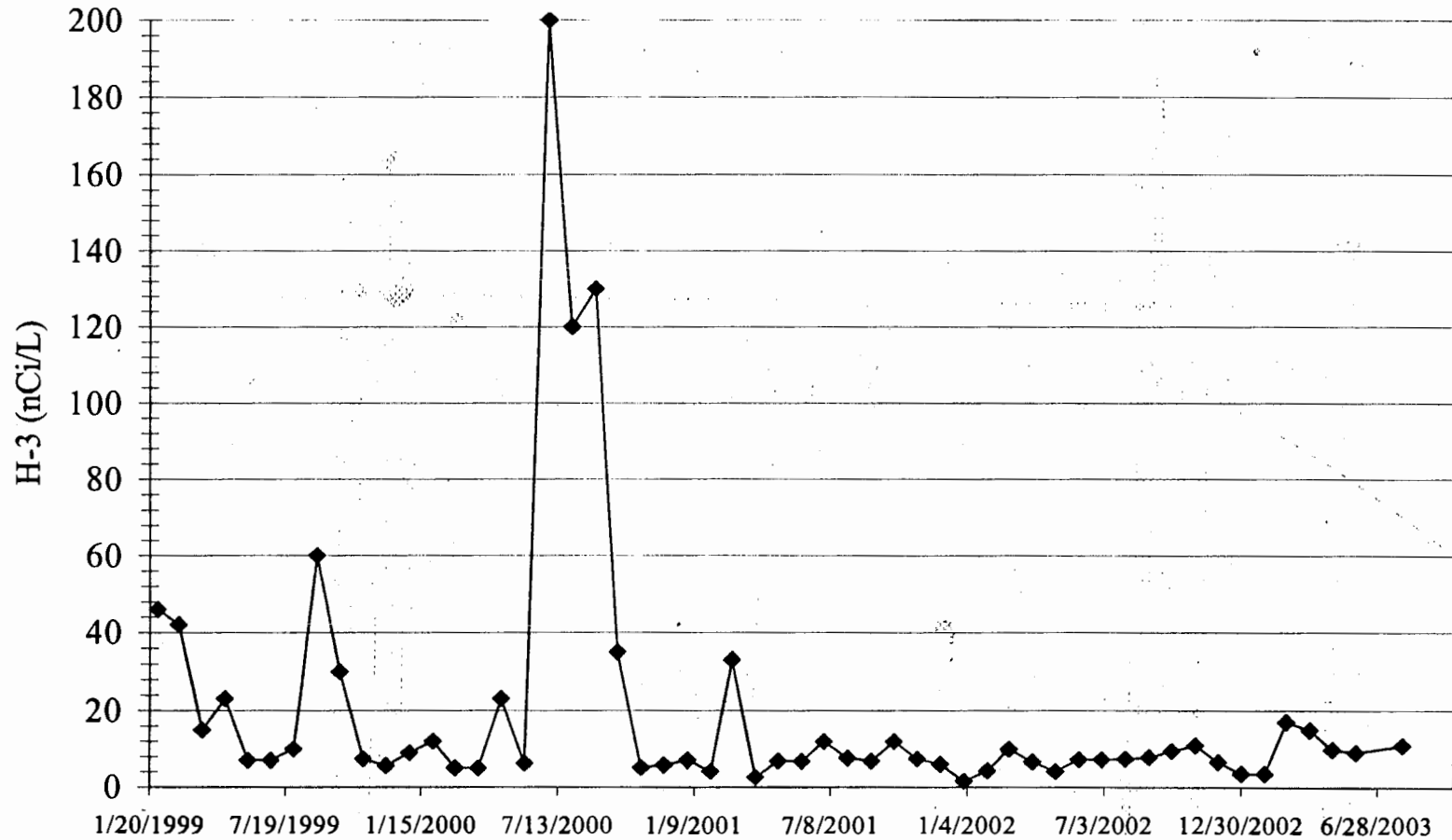

# Perchlorate—Reduction in RLWTF Effluent

Perchlorate in RLWTF Influent and Effluent from May 2001 - August 2003  
Analysis of Flow Weighted Weekly Composite Samples

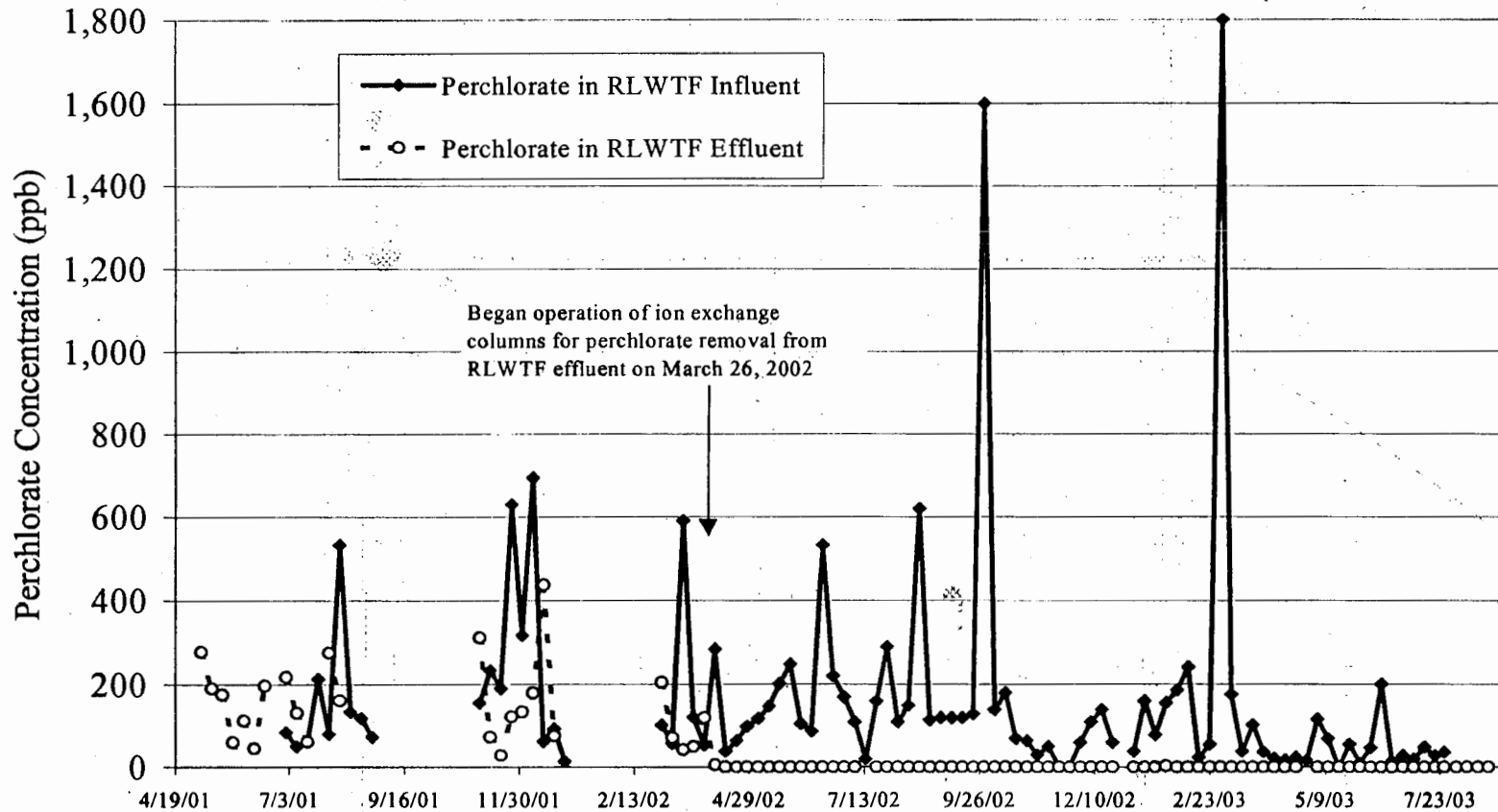

### Nitrate-Nitrogen in RLWTF Effluent Discharges

NMED Groundwater Standard = 10 mg/L  
Average from 12/10/99 - 6/30/01  
is 3.9 mg/L  $\text{NO}_3\text{-N}$   
(372 effluent tanks)

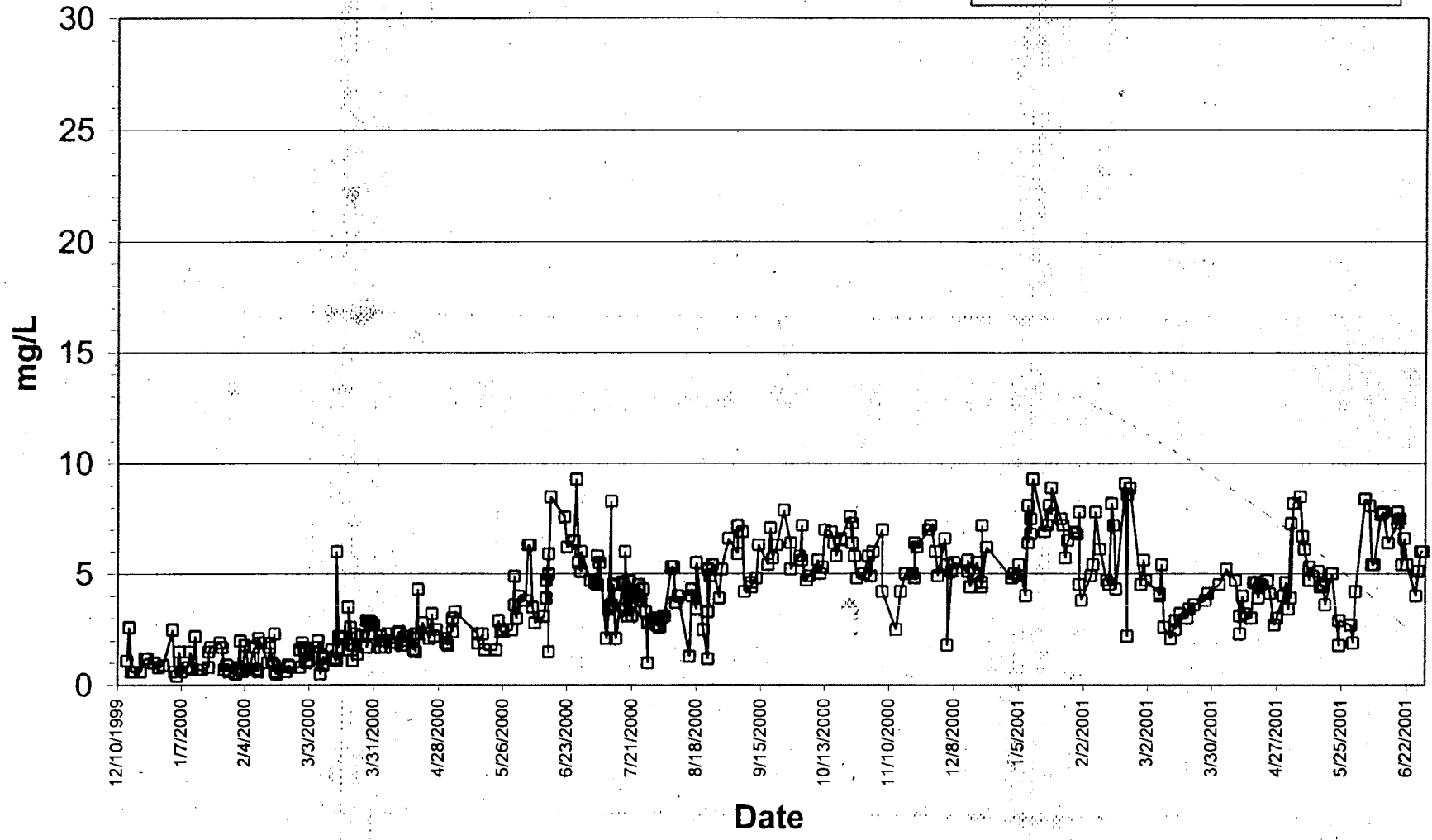

**Radioactive Liquid Waste Treatment Facility  
Ground Water Discharge Plan (DP-1132) Quarterly Report  
3rd Quarter, 2003**

**Table 2.0. RLWTF Weekly Effluent Monitoring Analytical Results, 3rd Quarter, 2003.**

<b><u>JUNE, 2002</u></b>	6/24/2003	<0.01	<0.06	109
	6/30/2003	<0.01	0.10	134
<b><u>JULY, 2003</u></b>	7/7/2003	<0.01	0.13	124
	7/15/2003	0.02 <sup>J</sup>	0.15	121
	7/18/2003	0.04 <sup>J</sup>	0.16	143
	7/29/2003	<0.01	0.15	183
<b><u>AUGUST, 2003</u></b>	8/5/2003	0.07	0.16	143
	8/13/2003	0.05	0.07 <sup>J</sup>	75
	8/19/2003	0.18	0.12	105
	8/26/2003	0.58	0.12	81
<b><u>SEPTEMBER, 2003</u></b>	9/3/2003	0.39	0.16	150
	9/9/2003	0.36	0.10	126
	9/15/2003	0.67	0.16	129
	9/23/2003	0.70	0.16	61
<b>3rd Quarter 2003 Averages (mg/L)</b>		<b>0.22</b>	<b>0.13</b>	<b>120</b>
<b>NM WQCC 3103. Ground Water Standards (mg/L)</b>		<b>10.0<sup>4</sup></b>	<b>1.6</b>	<b>1000</b>

**Notes:**

<sup>1</sup>Results for these analyses are pending validation.

<sup>2</sup>A duplicate sample result.

<sup>4</sup>The NMWQCC Regulation 3103, Ground Water Standard is for NO<sub>3</sub>-N

All analyses by the General Engineering Laboratories, Charleston, South Carolina.

TA-50 PLW Treatment Facility Ground Water Discharge Plan - Monitoring Wells

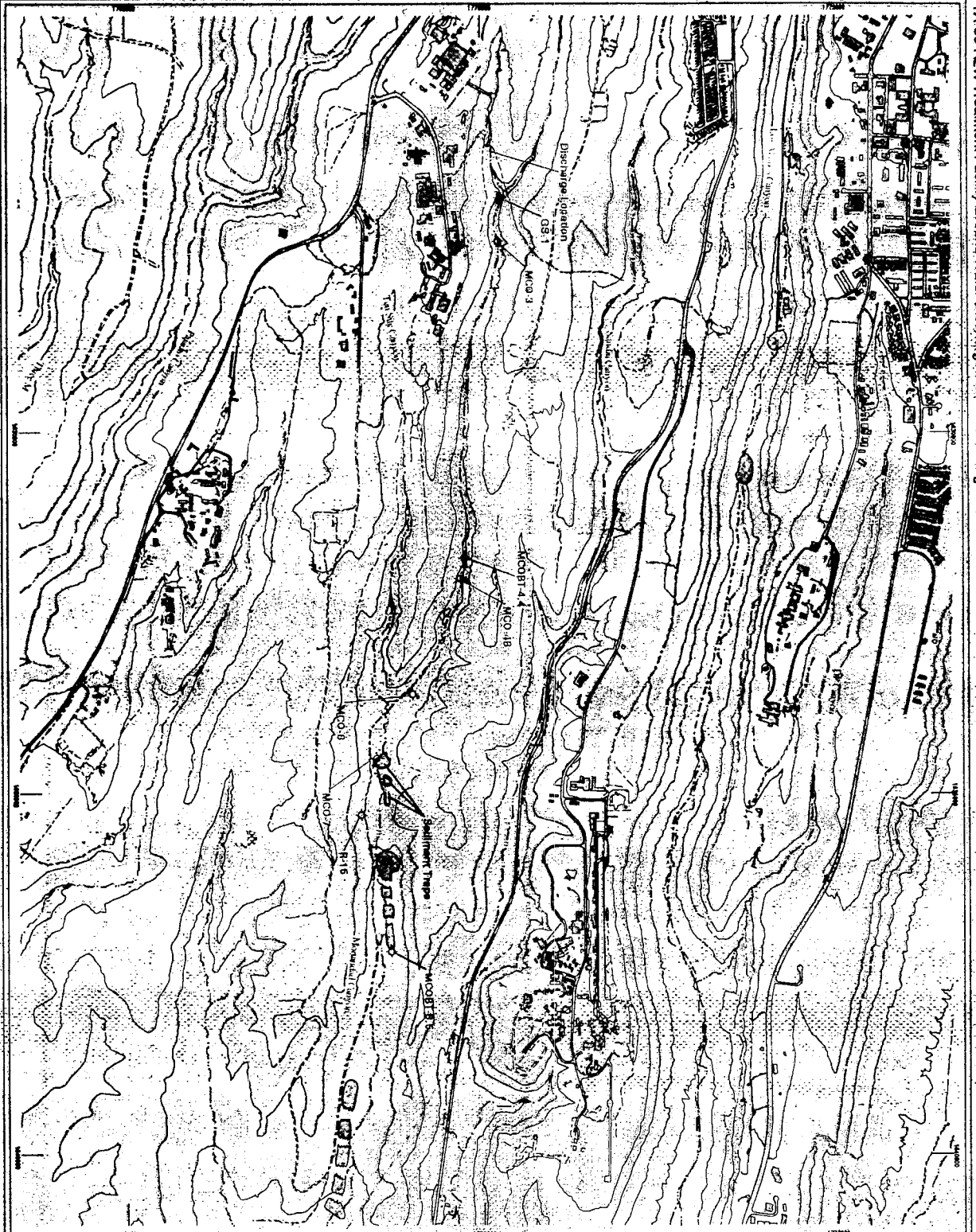

- LEGEND**
- ☒ Contour: 100 ft
  - ☒ Contour: 20 ft
  - ☒ Reclamation Stream
  - ☒ Road: Paved
  - ☒ Building 50-01
  - ☒ Sediment Trap
  - ☒ Structure
  - ☒ Weiland
  - ☒ Stream Gaging Station
  - ☒ Discharge from Monitoring Well
  - ☒ Other Monitoring Well

- Discharge Point Monitoring Wells**
- MCO-1
  - MCO-2
  - MCO-3
  - MCO-4
  - MCO-5
  - MCO-6
  - MCO-7
- Non-Discharge Point Monitoring Wells**
- MCO-8
  - MCO-9
  - MCO-10
  - MCO-11
  - MCO-12
  - MCO-13
  - MCO-14
  - MCO-15
  - MCO-16
  - MCO-17
  - MCO-18
  - MCO-19
  - MCO-20
  - MCO-21
  - MCO-22
  - MCO-23
  - MCO-24
  - MCO-25
  - MCO-26
  - MCO-27
  - MCO-28
  - MCO-29
  - MCO-30
  - MCO-31
  - MCO-32
  - MCO-33
  - MCO-34
  - MCO-35
  - MCO-36
  - MCO-37
  - MCO-38
  - MCO-39
  - MCO-40
  - MCO-41
  - MCO-42
  - MCO-43
  - MCO-44
  - MCO-45
  - MCO-46
  - MCO-47
  - MCO-48
  - MCO-49
  - MCO-50
  - MCO-51
  - MCO-52
  - MCO-53
  - MCO-54
  - MCO-55
  - MCO-56
  - MCO-57
  - MCO-58
  - MCO-59
  - MCO-60
  - MCO-61
  - MCO-62
  - MCO-63
  - MCO-64
  - MCO-65
  - MCO-66
  - MCO-67
  - MCO-68
  - MCO-69
  - MCO-70
  - MCO-71
  - MCO-72
  - MCO-73
  - MCO-74
  - MCO-75
  - MCO-76
  - MCO-77
  - MCO-78
  - MCO-79
  - MCO-80
  - MCO-81
  - MCO-82
  - MCO-83
  - MCO-84
  - MCO-85
  - MCO-86
  - MCO-87
  - MCO-88
  - MCO-89
  - MCO-90
  - MCO-91
  - MCO-92
  - MCO-93
  - MCO-94
  - MCO-95
  - MCO-96
  - MCO-97
  - MCO-98
  - MCO-99
  - MCO-100



Prepared by: [Name]  
 Date: [Date]  
 Scale: 1" = 100'





**ive Liquid Waste Treatment Facility  
Water Discharge Plan (DP-1132) Quarterly Report  
ter, 2003**

**Table 1.0. Mortandad Canyon Alluvial Monitoring Wells Analytical Results, 3rd Quarter, 2003.**

Sample ID	Sample Date	Sample Volume (L)	Ammonia (mg/L)	Nitrate (mg/L)	Nitrite (mg/L)	Total Solids (mg/L)	Total Phosphorus (mg/L)
MCO-3	8/11/2003	2,35J	2.81	0.34	<0.024	310	0.621
MCO-4B	8/13/2003	10.4	2.4	0.30	<0.024	400	0.865
MCO-6	8/14/2003	15.8	2.78	0.24	<0.024	415	0.940
MCO-7	8/14/2003	60.4	3.50	0.23	<0.024	342	1.21
<i>NM WQCC 3103. Ground Water Standards (mg/L)</i>			$10^2$			1000	1.6

**Notes:**

<sup>1</sup>NS means that there was not sufficient water available for sampling.

<sup>2</sup>The NMWQCC Regulation 3103. Ground Water Standard is for  $\text{NO}_3\text{-N}$ .

<sup>3</sup>Nonfiltered sample.

J indicates an estimated value. The result was less than the reporting limit, but greater than the detection limit.

All analyses by General Engineering Laboratories, Charleston, SC.

All samples filtered unless otherwise noted.

# TA-50 Discharge Volumes 1963-2002

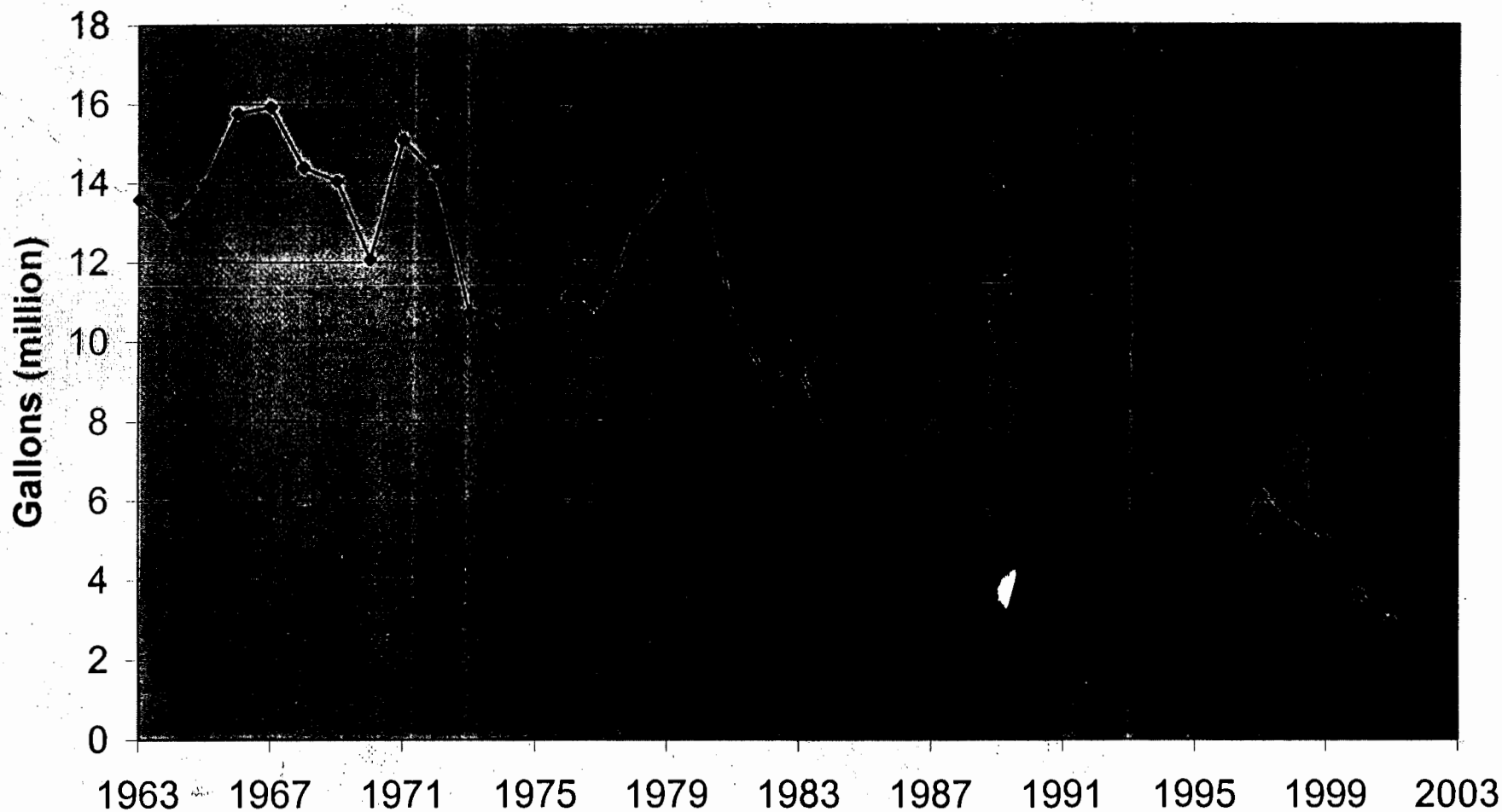

### Annual Discharge Volumes Mortandad Canyon 1964-2002

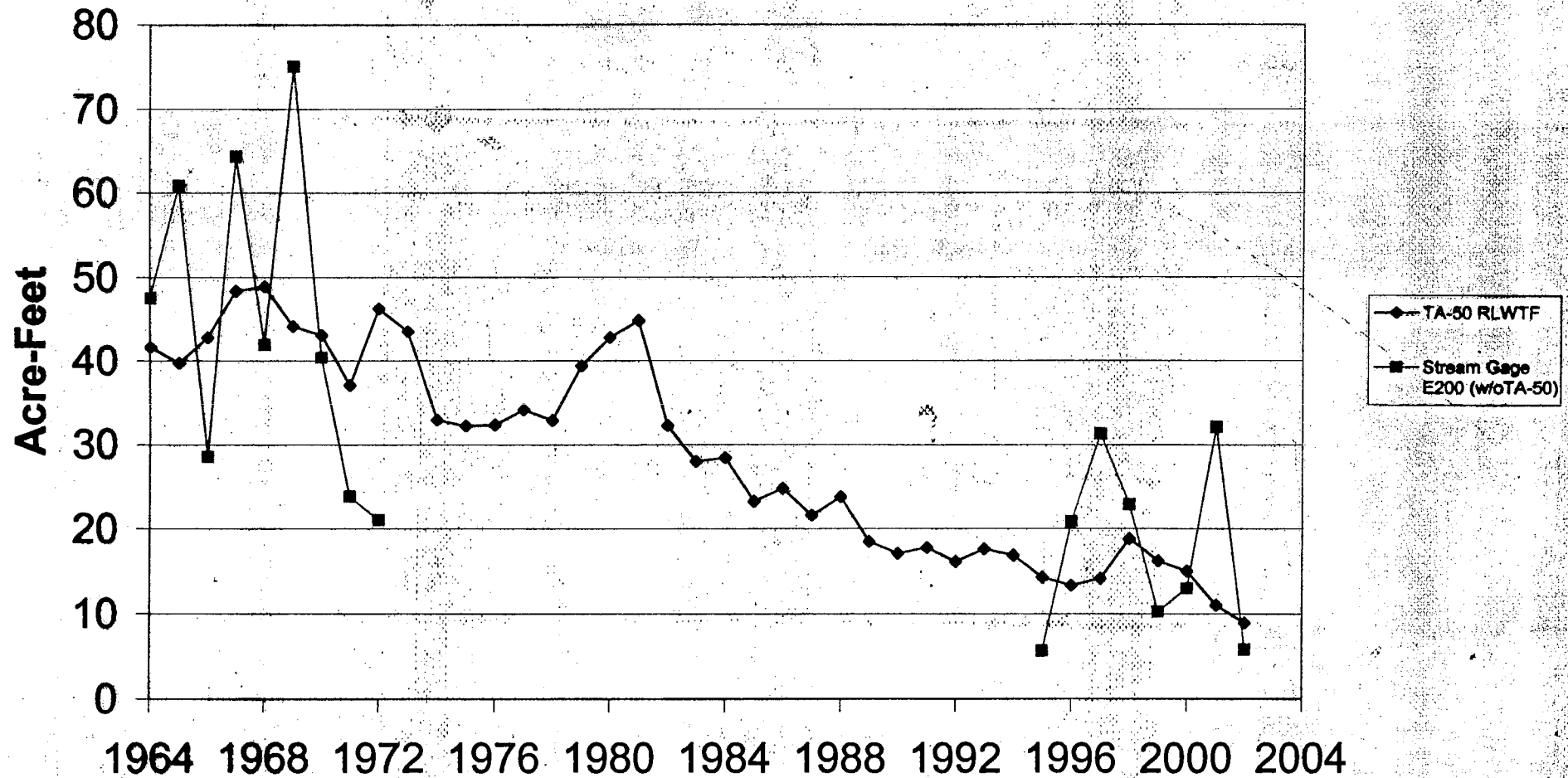

**TA-50 Portion of Annual Discharge Volumes  
Mortandad Canyon 1995-2002  
Average Ratio: 0.49**

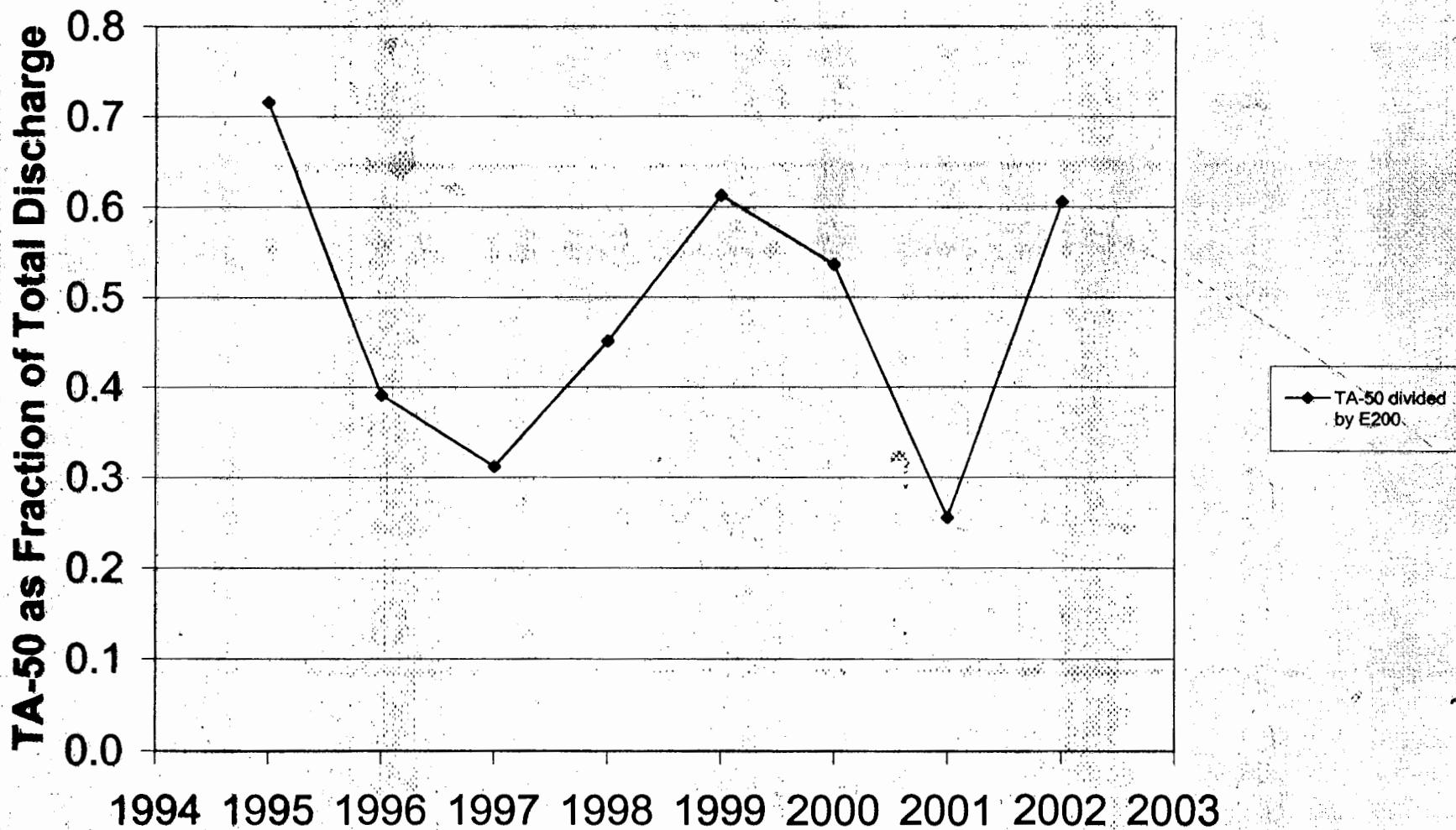



**TA-50 Portion of Annual Discharge Volumes  
Mortandad Canyon 1963-1972  
Average Ratio: 0.51**

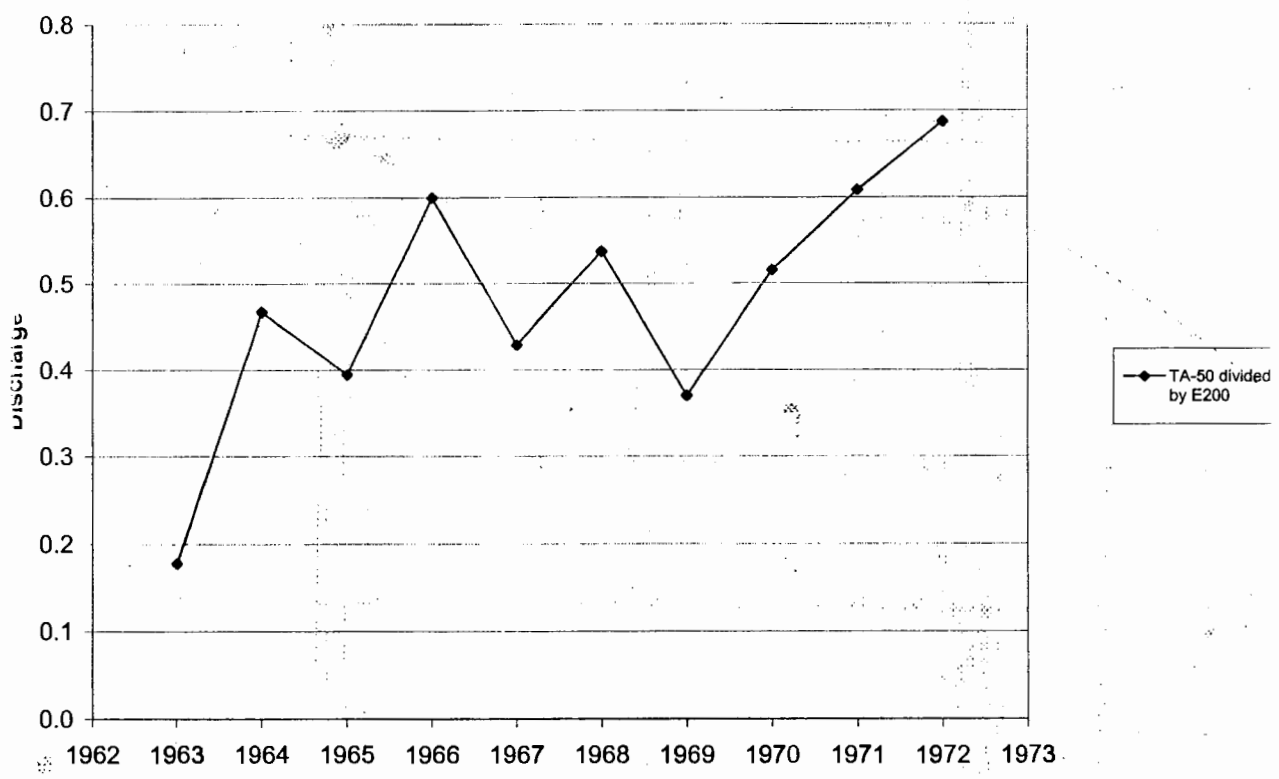

# Proposed Schedule

---

---

- **Drilling and Field Activities**
  - o Oct 2003 - December 2004
- **Sample Collection and Analysis**
  - o July 2004 - July 2005
- **Report Preparation**
  - o July 2005 - December 2005
- **Report Submittal:**
  - o December 31, 2005

# Other Investigations

---

---

- **Infiltration Investigation:** constrain various terms of water budget to quantify deep percolation.
- **Colloid Investigation:** evaluate potential importance of colloids in the transport of adsorbed contaminants.

# Data Analysis and Interpretation

---

---

- **Guide data collection:** Real-time data analysis of characterization data for up-to-date interpretation of contaminant nature and extent.
- **Overall synthesis of data:** Numerical models of fate and transport through alluvial and vadose zone to underlying regional aquifer.



# Mortandad Canyon Groundwater Investigation

---

---

P. Longmire, K. Bitner, D. Broxton,  
D. Vaniman, T. Whitacre,  
R. Gray, & B. Robinson

Groundwater Protection Program  
Quarterly Meeting  
October 27, 2003

# Investigation Objectives

---

---

Collect data and information to:

- Determine nature and extent of contamination
- Estimate present-day human health and ecological risk *pathway analysis*
- Base corrective action decisions for PRS aggregates and groundwater
- Make recommendations for long-term monitoring

# Surface Water Sampling

- 1. Mortandad Canyon - east of Diamond Dr.
- 2. wetland near NPDES outfall at TA-3
- 3. Effluent Canyon wetland near head of canyon
- 4. wetland at TA-55
- 5. Effluent Canyon - 300 ft east of TA-50 discharge
- 6. Down stream of Effluent & Mont.
- 7. Ten site canyon east of TA-35

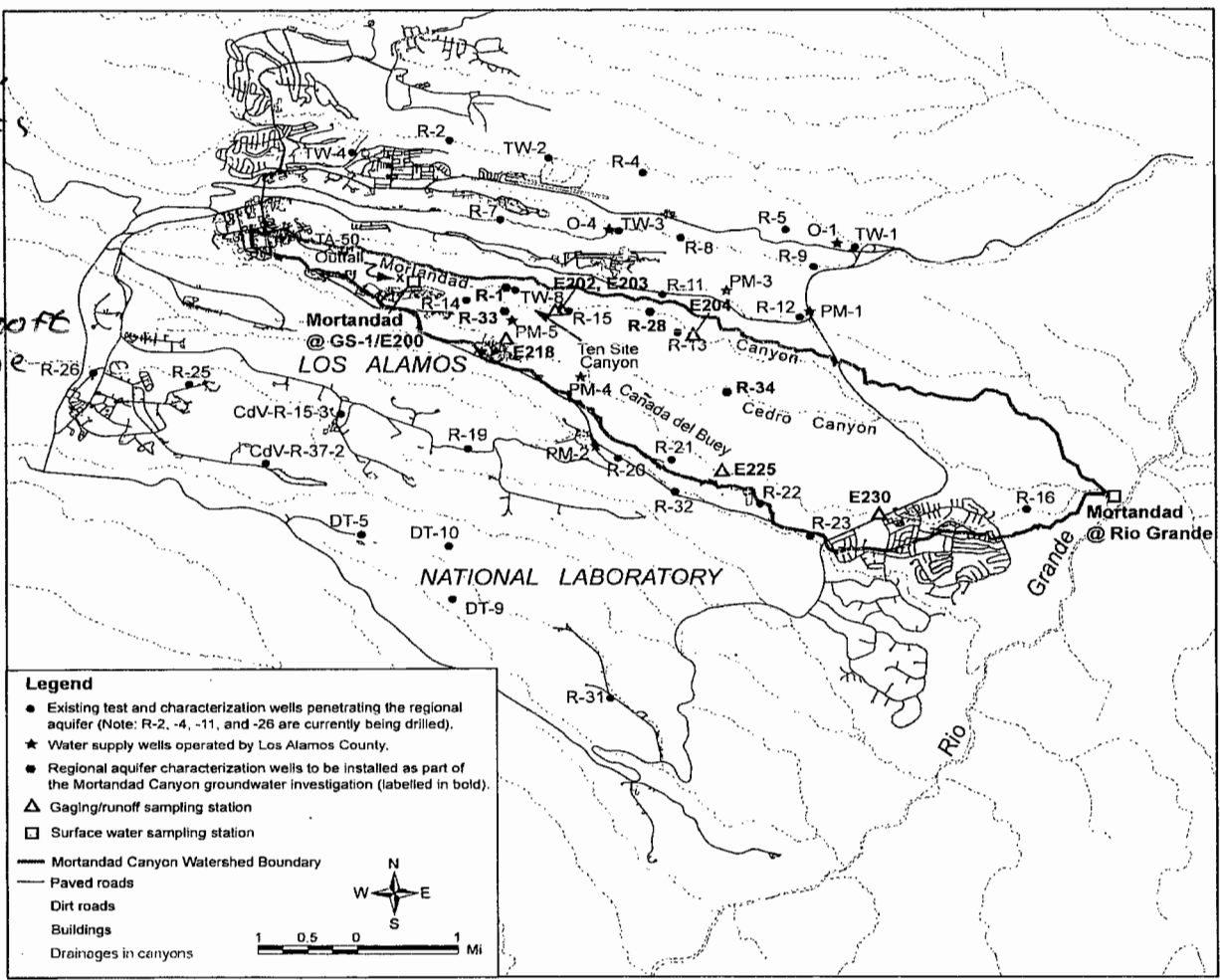

# Piezometers, Wells, & Boreholes

02306

Mortandad Canyon East

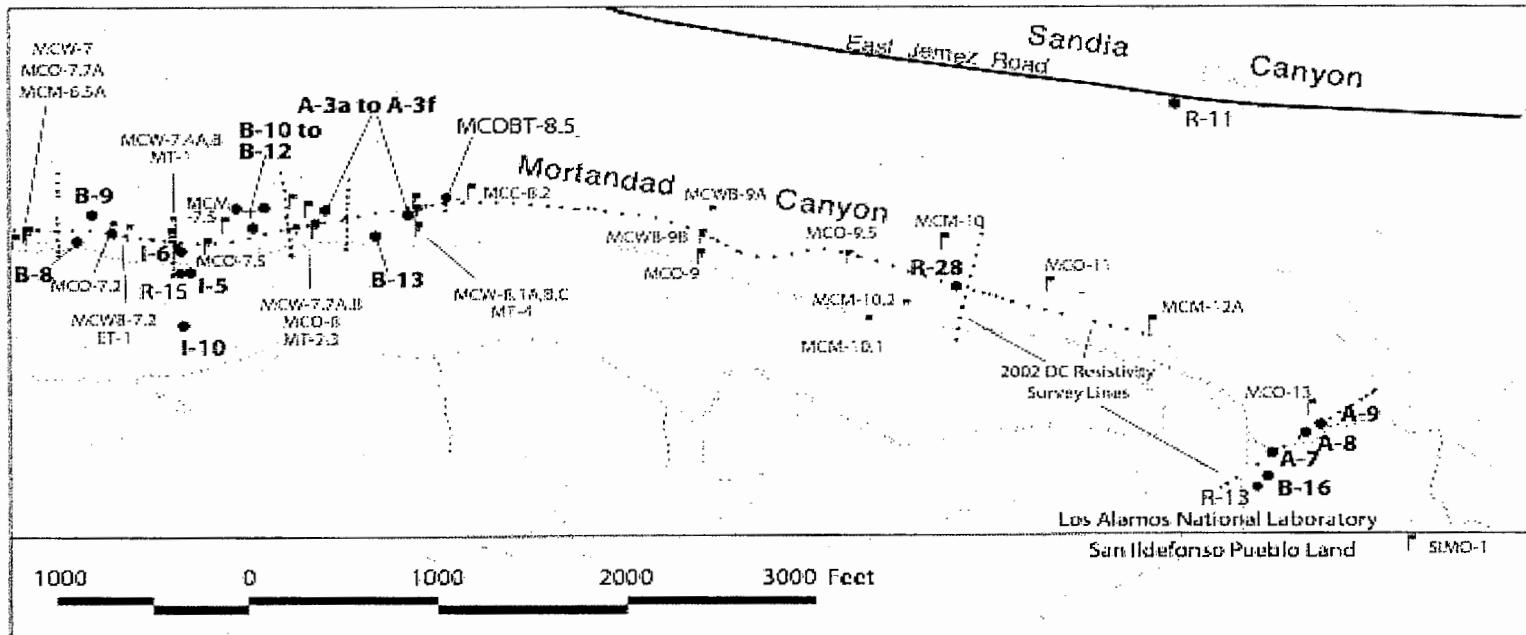

- Proposed wells under this workplan addendum. Note: R-17 is currently being installed under the Hydrogeologic Workplan.
- Wells installed since 1997 (as part of Mortandad Canyon Work Plan)
- Wells installed before 1997 (prior to Mortandad Canyon Work Plan)
- Buildings
- Topographic contours: interval = 20 ft
- Paved road
- Dirt road



UNCLASSIFIED





# Geophysical Surveys and Boreholes

02309

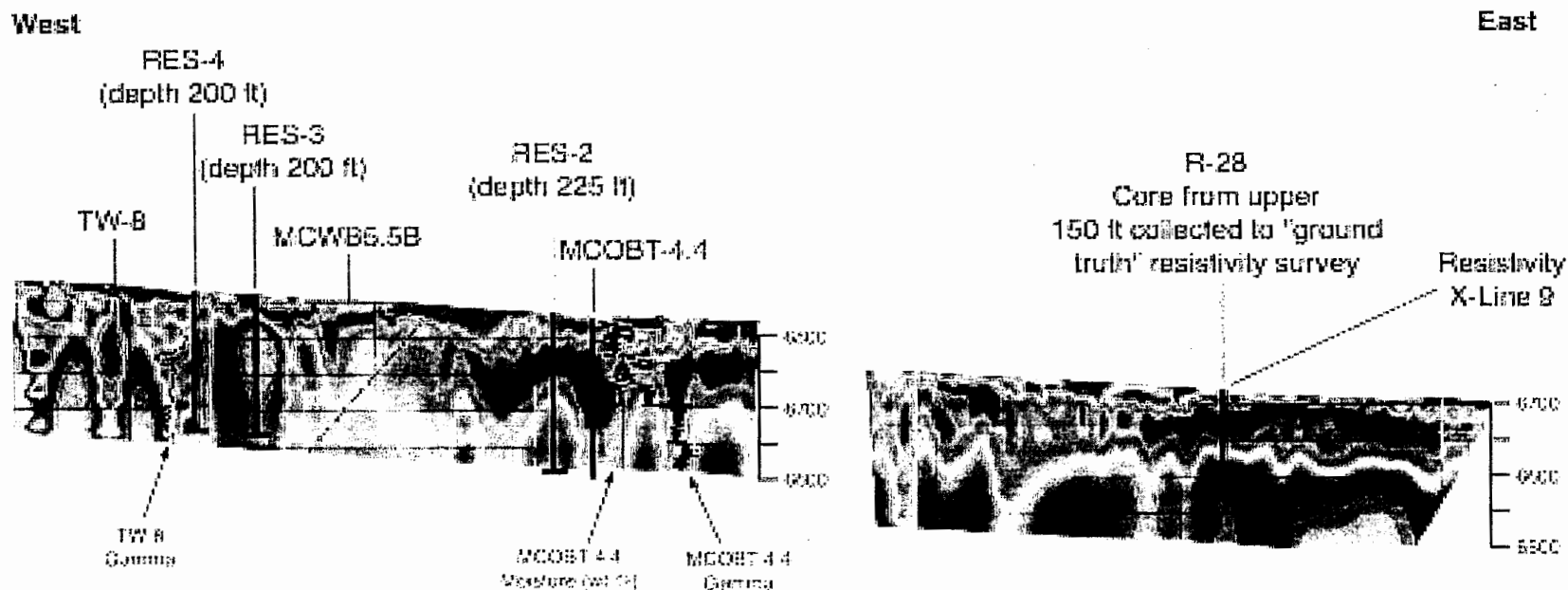

Colored profiles represent modeled DC resistivity values. The colored scale is nonlinear with cool colors (blue) representing conductive zones of 0 to  $-150$  Ohm-m, intermediate colors (yellow) representing zones of  $-600$  to  $700$  Ohm-m, and warm colors (red) representing resistive zones of  $2000$  to  $>6400$  Ohm-m.

# Scope of Field Work Summary

---

---

- Surface Water Sampling: 7 locations
- Piezometers: 6 locations
- Alluvial Wells: 9 locations
- Shallow Boreholes: 16 locations
- Intermediate Wells: 7 locations
- Regional Aquifer Wells: 4 locations
- Geophysical Surveys and Boreholes

# Present-Day Risk to Human Health and Ecological Receptors

---

---

- **Surface water:** sampling 7 areas of persistent water, ~~7~~<sub>2</sub> sampling events.
- **R-28:** point between R-15 (contaminants present) and R-13 (contaminants absent).
- **R-33:** sentry well for PM-5.
- **Geomorphic surveys:** conducted under RFI Work Plan for Mortandad Canyon.



# Location of Contaminants and Extent of Impact on Regional Aquifer

---

---

## 4 regional aquifer wells:

- R-1 (TW-8 replacement): where canyon widens.
- R-28: point between R-15 (contaminants present) and R-13 (contaminants absent).
- R-33: sentry well for PM-5.
- R-34: San Ildefonso Pueblo monitoring point.

# Perched Zones and Role in Contaminant Transport

---

---

- Geophysical surveys and boreholes to identify potential perched water in Bandelier Tuff (done first).
- 7 intermediate wells: collect core and borehole and well water samples; possible hydrologic testing.
- 4 regional aquifer wells: identify the presence of intermediate zones encountered and collect boreholes water samples.

# Extent and Depth of Contaminant Fronts

---

---

Core and/or water samples to measure moisture, anions, stable isotopes, & contaminants from:

- 9 alluvial wells
- 16 shallow (<100 ft) boreholes
- 7 intermediate wells
- 4 regional aquifer wells

# Location and Rate of Water Infiltration

---

---

- **Infiltration investigation:** Location and rate of surface water infiltrating into the subsurface.
- **Piezometers:** 6 to determine alluvial groundwater movement east of sediment traps.
- **Boreholes:** 16 shallow boreholes, core samples to measure moisture, anions, stable isotopes, contaminants.
- **Alluvial Wells:** 9 wells to augment contaminant distribution information.
- **Geophysical Surveys:** DC resistivity to identify potential zones of infiltration.

# Conceptual Model Uncertainties

---

---

- Location and rate of water infiltration
- Extent and depth of strongly adsorbing, moderately adsorbing, and non-adsorbing contaminant fronts
- Presence of perched zones and role in contaminant transport
- Location of contaminants and extent of impact on regional aquifer
- Present-day risk to human health and ecological receptors

# Hydrogeologic and Contaminant Conceptual Model

02316

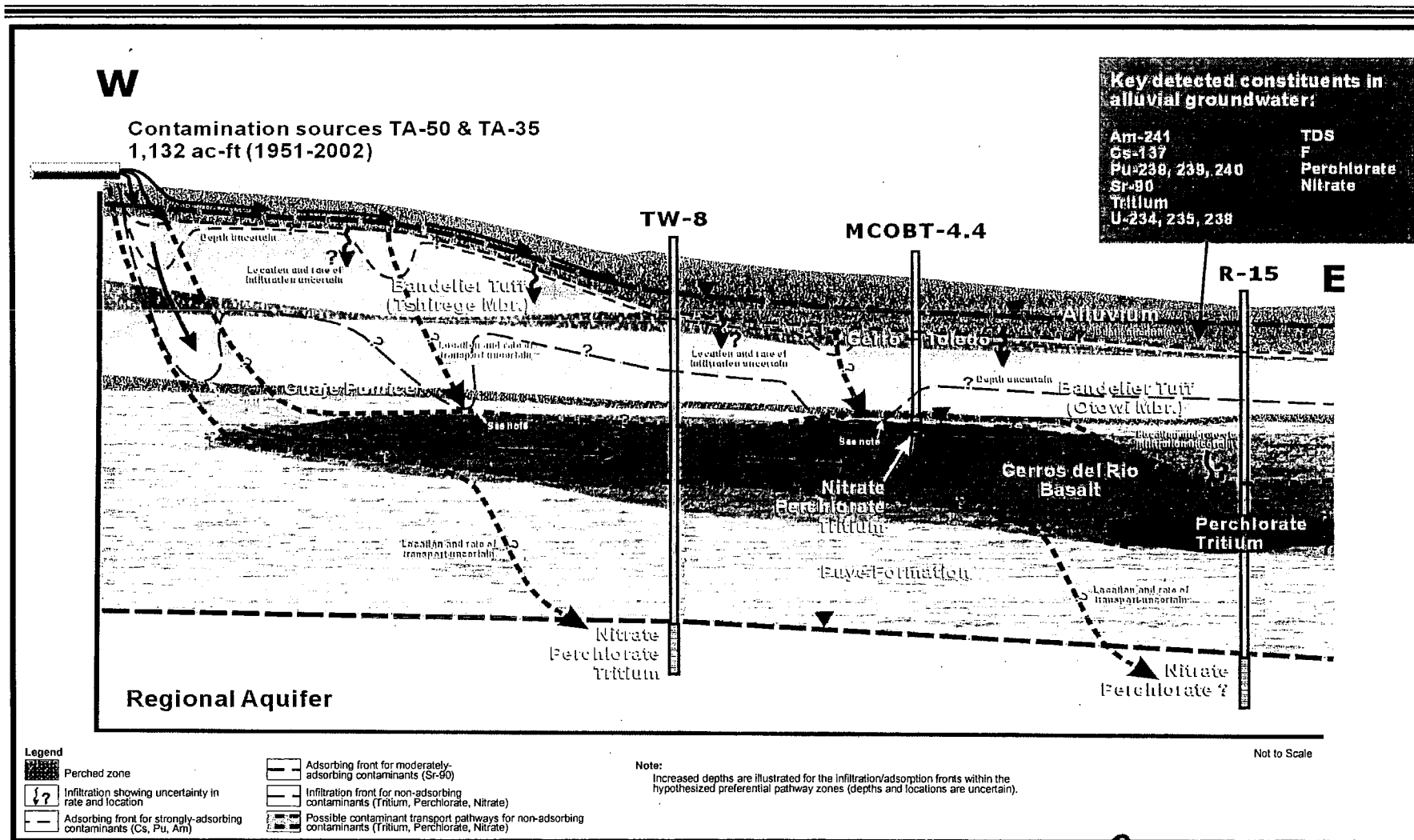

UNCLASSIFIED



NAMEORGANIZATIONPHONE NUMBER

Curt Frischkorn	NMED-GWQB	827-0078
Karma Anderson	NMED-GWQB	827-0629
Patrick Longmire	LANL-EES-6	665-1264
Pete Worland	LANL-FWO-WFM	665-7167
Kathy Sanchez	Tewa Woman United	747-7100 / 747-3259
Peggy Pruvic	Peace Action N.M.	989-4812
BOB BEERS	LANL-WQH	667-7969
GEORGE RICE	CCNS	210-737-6180
JONI ARENDS	CCNS	986-1973
John Young	NMED-HWB	428-2538

NAMEORGANIZATIONPHONE NUMBER

Curt Frischkorn

NMED-GWRB

827-0078

Karma Anderson

NMED-GWRB

827-0629

Patrick Longmire

LANL-EES-6

665-1264

Pete Worland

LANL-FWO-WFM

665-7167

Kathy Sanchez

Tewa Women United

747-7100 / 747-3259

Peggy Prance

PEACE ACTION N.M.

989-4812

BOB BEERS

LANL-WQH

667-7969

George Rice

CCNS

210-737-6180

JONI ARENDS

CCNS

986-1973

John Young

NMED-HWB

428-2538



NAMEORGANIZATIONPHONE NUMBER

Curt Frischkorn	NMED-GWQB	827-0078
Karma Anderson	NMED-GWQB	827-0629
Patrick Longmire	LANL-EES-6	665-1264
Pete Worland	LANL-FWO-WFM	665-7167
Kathy Sanchez	Texas Women United	747-7100 / 747-3259
Peggy Prunice	PEACE ACTION N.M.	989-4812
BOB BEERS	LANL-WQH	667-7969
GEORGE RICE	CCNS	210-737-6180
JONI ARENDS	CCNS	986-1973
John Young	NMED-HWB	428-2538

<u>NAME</u>	<u>ORGANIZATION</u>	<u>PHONE NUMBER</u>
Curt Frischkorn	NMED-GWQB	827-0078
Karma Anderson	NMED-GWATS	827-0629
Patrick Longmire	LANL-EES-6	665-1264
Pete Worland	LANL-FWO-WFM	665-7167
Kathy Sanchez	Tewa Women United	747-7100 / 747-3259
Peggy Pruvic	Peace Action N.M.	989-4812
BOB BEERS	LANL-WQHT	667-7969
GEORGE RICE	CCNS	210-737-6180
JONI ARENDS	CCNS	986-1973
John Young	NMED-HWJB	428-2538





DEC 23 2003  
RECEIVED

Risk Reduction & Environmental Stewardship Division  
Water Quality & Hydrology Group (RRES-WQH)  
PO Box 1663, MS K497  
Los Alamos, New Mexico 87545  
(505) 667-7969/Fax: (505) 665-9344

Date: December 23, 2003  
Refer to: RRES-WQH: 03-332

Mr. Curt Frischkorn  
Ground Water Pollution Prevention Section  
Ground Water Quality Bureau  
New Mexico Environment Department  
P.O. Box 26110  
Santa Fe, New Mexico 87502

**SUBJECT: TA-50 RADIOACTIVE LIQUID WASTE TREATMENT FACILITY, GROUND WATER DISCHARGE PLAN (DP-1132), REQUEST FOR ADDITIONAL INFORMATION**

Dear Mr. Frischkorn:

On November 10, 2003, at your request, staff from Los Alamos National Laboratory presented information pertaining to the TA-50 Radioactive Liquid Waste Treatment Facility (RLWTF) Groundwater Discharge Plan (DP-1132) to representatives from the following organizations: NMED Groundwater Quality and Hazardous Waste Bureaus, Concerned Citizens for Nuclear Safety (CCNS), Tewa Women United, and Peace Action New Mexico. During the Laboratory's presentation a number of questions were asked that could not be immediately answered by Laboratory staff. On November 20, 2003, we discussed these questions and identified eight that the Laboratory would formally address. Below, these eight questions are presented and answered.

1) **Question by Peggy Prince, Peace Action New Mexico**

During discussions about the 1999 nitrate moratorium, Peggy Prince asked, *Where are the heavy hitters (term used by Pete Worland) located and where is their nitrogen waste sent for treatment and disposal?*

**LANL Response**

One of the more significant generators of nitric acid waste was the analytical laboratory conducting urinalysis studies. Nitric acid waste generated during urinalysis was initially sent offsite to a hazardous waste treatment and disposal facility because it has a very low pH. Presently, this waste is neutralized onsite and is sent to the Laboratory's TA-46 Sanitary Wastewater Systems (SWWS) Facility where the nitrates are treated by biological denitrification.

Another generator of nitric acid waste is the TA-55 facility. Since 1999 nitric acid waste generated at the TA-55 facility has been treated separately at the RLWTF from non-TA-55 liquid wastewater. This nitrate containing wastewater is first neutralized and then filtered to remove alpha emitting radionuclides. The effluent water from this process is then evaporated. The concentrated "bottoms" from the evaporator are solidified with cement and disposed of as low-level waste at the TA-54 radioactive solid waste landfill. The distillate from the evaporation process is processed through the RLWTF and discharged to the environment via NPDES Permitted Outfall 051 in Mortandad Canyon.

2) **Question by John Young, NMED**

*Are NARS waste streams that go to Room 60 at the RLWTF permitted under NPDES or RCRA?*

**LANL Response**

Liquid waste from NARS is permitted under the Laboratory's NPDES Permit No. NM0028355. The Nitric Acid Recovery System (NARS) located at TA-55, PF-4, is a distillation column that reclaims the nitric acid generated during TA-55 plutonium processing operations. When NARS is operating, the bottom of the distillation column produces 12 M nitric acid. All nitric acid produced by NARS is then transferred to the product storage tank for reuse in TA-55 operations. The distillate extracted from the condenser at the top of the distillation column consists of water and approximately 45 ppm nitric acid. This liquid waste is discharged by TA-55 to Room 60 at the RLWTF via the RLW Collection System's "Acid" waste line (See RLWTF Flow Schematic). Radioactive liquid wastewater discharged to Room 60 is pre-treated then sent to the volume reduction evaporator. Distillate from the volume reduction evaporator is discharged through NPDES Permitted Outfall 051 to Mortandad Canyon.

A RCRA permit is not required for the NARS distillate piped to Room 60 at the RLWTF because it is subject to regulation under the NPDES permit as allowed by the wastewater treatment unit specific permit exclusion at 20.4.1.900 NMAC, incorporating 40 CFR 270.1(c)(2)(v). Further processing of the distillate in Room 60 through cementation is subject to regulation by 20.4.1.300 NMAC, incorporating 40 CFR 262.34(a), as a RCRA <90 day storage area (LANL Site ID #1778) rather than by permit. The bottom material (12 M nitric acid) produced by the NARS process is not RCRA regulated as it is re-used in the TA-55 plutonium processing operations and is excluded as a RCRA solid waste through closed loop recycling by reclamation exemption at 20.4.1.200 NMAC, incorporating 40 CFR 261.4(a)(8).

3) **Question by Curt Frischkorn, NMED**

*Is NARS a pre-treatment unit for the TA-50 RLWTF?*

**LANL Response**

NARS is not a pre-treatment unit for the TA-50 RLWTF. NARS is a process unit owned and operated by the Nuclear Materials Technology Division (NMT) for the intended purpose of reclaiming nitric acid for reuse in PF-4 operations.

4) **Question by Curt Frischkorn, NMED**

*Does the Laboratory have any explanation for the elevated chromium in MCOBT-4.4?*

**LANL Response**

The dissolved concentration of chromium in MCOBT-4.4 is approximately 0.050 mg/L which is also the NMWQCC groundwater standard for Cr. Possible sources of Cr at MCOBT-4.4 include natural and/or Laboratory releases. Analytical results from surveillance monitoring of alluvial groundwater in Mortandad Canyon show concentrations of Cr typically less than 0.020 mg/L. Chemically-altered portions of the Cerros del Rio basalt may contain natural Cr(III) that can be oxidized to Cr(VI). Under oxidizing conditions, Cr(VI) is stable as CrO<sub>4</sub><sup>2-</sup> and under alkaline pH conditions this anion is semi-adsorbing. The perched intermediate depth groundwater at MCOBT-4.4 is both oxidizing and has an alkaline pH, so some Cr dissolved in the groundwater would be expected under these conditions. The source of Cr at MCOBT-4.4 will be evaluated further during preparation of the final geochemistry report (which will be published in CY04).

Four quarterly sampling events have been completed at MCOBT-4.4 with the last event conducted in May, 2003. Analytical results from these sampling events were reported to the NMED in the Laboratory's Groundwater Protection Program Quarterly Reports.

No future sampling at MCOBT-4.4 is planned at this time. MCOBT-4.4 will be plugged and abandoned due to suspected leakage and replaced with another intermediate well (I-4) as one of the activities in the Mortandad Canyon Groundwater Investigation Work Plan. Further information on the replacement of MCOBT-4.4 can be found in the attached Mortandad Canyon Groundwater Investigation Work Plan (see page 28).

**5) Question by Curt Frischkorn, NMED**

*Does the Laboratory have any explanation for the 'rebound' effect that is occurring in the Permeable Reactive Barrier (Sr-90 and ClO<sub>4</sub> concentrations drop, then recover)?*

**LANL Response**

Low flow rates in the alluvium probably have resulted in incomplete flow throughout the Permeable Reactive Barrier (PRB), especially in the limestone cell. More sampling and tracer testing at the PRB are required to test this hypothesis.

**6) Question by Joni Arends, CCNS**

Following Pete Worland's discussion regarding the low concentrations of Sr-90 and Cs-137 presently in the RLWTF's influent (and effluent), Joni Arends asked, *What were the historical concentrations of Sr-90 and Cs-137 discharged to Mortandad Canyon?*

**LANL Response**

Regarding Strontium-90 discharges from the RLWTF:

From 1980 through 2002, Sr-90 concentrations in the RLWTF effluent were typically less than 100 pCi/L. During this 22-year period, only four monthly composite samples were greater than 5 nCi/L (5,000 pCi/L). The highest monthly composite sample was 39 nCi/L (39,000 pCi/L) and occurred in early 1991. Sr-90 is regulated under DOE Order 450.1 by the U.S. Department of Energy. The TA-50 RLWTF's effluent has met the DOE Derived Concentration Guidelines (DCGs) since December 1999.

Regarding Cesium-137 discharges:

From 1980 through 1990, Cs-137 concentrations in the RLWTF effluent were typically less than 5 nCi/L (5,000 pCi/L). From 1991 through 2002, Cs-137 in the RLWTF effluent has trended downward from less than 500 pCi/L to less than 10 pCi/L. During this 22-year period, three monthly composite samples were greater than 10 nCi/L (10,000 pCi/L). The highest monthly composite sample was 24 nCi/L (24,000 pCi/L) and occurred in early 1991 during the same month as the highest Sr-90 discharge that was mentioned previously. Cs-137 is regulated under DOE Order 450.1 by the U.S. Department of Energy

7) Question by Curt Frischkorn, NMED

*Can I have a copy of the draft Mortandad Canyon Workplan addendum?*

LANL Response

A copy is attached.

8) Question by Kathy Sanchez, Tewa Women United

*What caused the tritium spike in RLWTF's effluent in July, 2000?*

LANL Response

The tritium concentrations in the July, August and September, 2000, monthly composite effluent samples were 200, 120 and 130 nCi/L, respectively. The 20 months prior to those three months had averaged less than 30 nCi/L tritium. The 39 months since those three months have averaged less than 20 nCi/L tritium. The "spike" in tritium in the RLWTF effluent during those three months was due to receiving some more highly concentrated tritiated wastewater from a specific facility. This highly tritiated water is now segregated from the other RLWTF influent wastewater and treated through the plant so as to maintain effluent tritium concentrations at less than 20 nCi/L (the federal drinking water standard for tritium is 20 nCi/L).

Please contact me at (505) 667-7969 if you would like additional details regarding this information.

Sincerely,



Bob Beers  
Water Quality & Hydrology Group

BB/tml

Attachment: a/s

Cy: J. Young, NMED/HWB, Santa Fe, NM, w/att.  
C. Will, NMED/HWB, Santa Fe, NM, w/att.  
M. Leavitt, NMED/SWQB, Santa Fe, NM, w/att.  
C. Voorhees, NMED/DOE/OB, Santa Fe, NM, w/att.  
R. Ford-Schmid, NMED/DOE/OB, Santa Fe, NM, w/att.  
J. Vozella, DOE/OLASO, w/o att., MS A316  
G. Turner, DOE/OLASO, w/o att., MS A316  
J. Holt, ADO, w/o att., MS A104  
T. Stanford, FWO-DO, w/o att., MS K492  
D. McClain, FWO-WFM, w/o att., MS J593  
R. Alexander, FWO-WFM, w/o att., MS E518  
D. Moss, FWO-WFM, w/o att., MS E518  
P. Worland, FWO-WFM, w/o att., MS E518  
B. Ramsey, RRES-DO, w/o att., MS J591  
T. Grieggs, RRES-DO, w/o att., MS J591  
T. George, RRES-DO, w/o att., MS J591  
D. Stavert, RRES-EP, w/o att., MS J591  
G. Bacigalupa, RRES-SWRC, w/o att., MS K490  
J. Carmichael, RRES-SWRC, w/o att., MS E501  
S. Rae, RRES-WQH, w/o att., MS K497  
D. Rogers, RRES-WQH, w/o att., MS K497  
M. Saladen, RRES-WQH, w/o att., MS K497  
RRES-WQH File, w/att., MS K497  
IM-5, w/att., MS A150



# RLWTF Flow Schematic (CY 2002 basis)

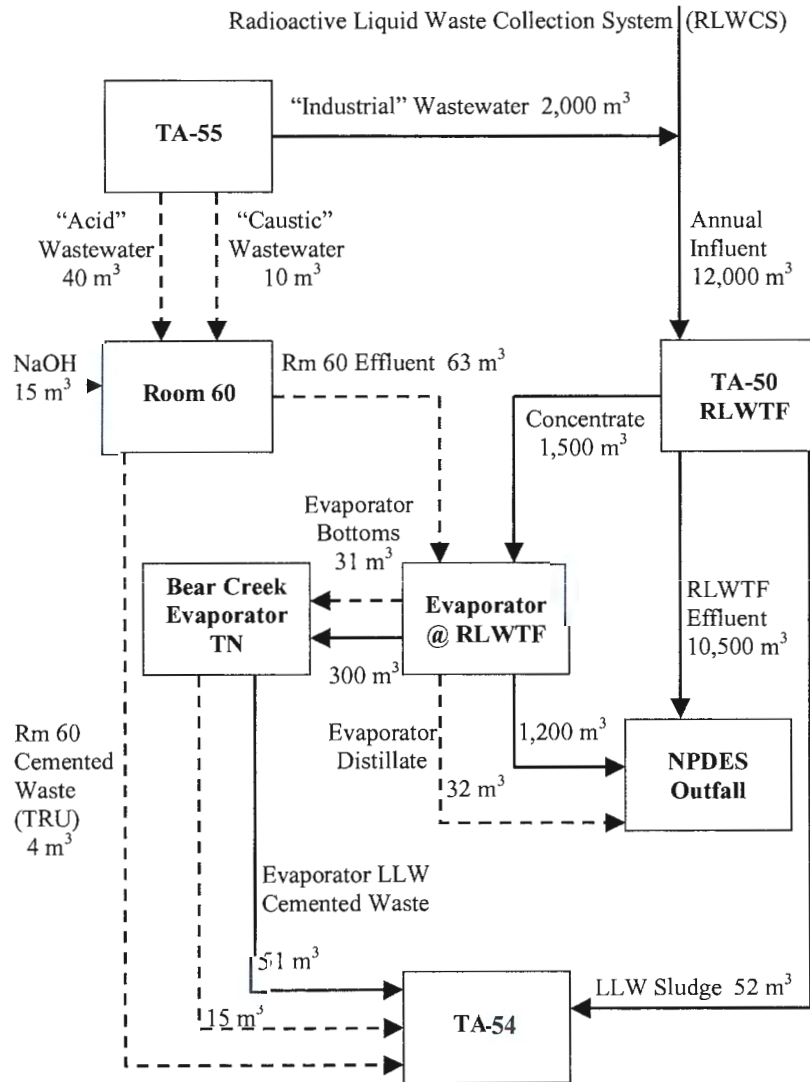

02227



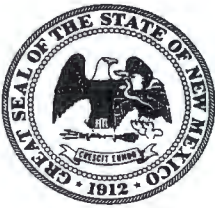

BILL RICHARDSON  
GOVERNOR

State of New Mexico  
**ENVIRONMENT DEPARTMENT**

Ground Water Quality Bureau  
Harold Runnels Building  
1190 St. Francis Drive, P.O. Box 26110  
Santa Fe, New Mexico 87502-6110

Telephone (505) 827-2918  
Fax (505) 827-2965



**CERTIFIED MAIL – RETURN RECEIPT REQUESTED**

March 4, 2004

Steven R. Rae, Group Leader  
Water Quality and Hydrology Group  
Risk Reduction and Environmental Stewardship Division  
Los Alamos National Laboratory  
P.O. Box 1663, MS K497  
(RRES-WQH)  
Los Alamos, New Mexico 87545

**RE: Request for Additional Information, DP-1132, Los Alamos National Laboratory**

Dear Mr. Rae:

The New Mexico Environment Department (NMED) has reviewed the application for the above referenced facility in accordance with the New Mexico Water Quality Control Commission Regulations (20.6.2 NMAC). The following additional information is necessary, pursuant to Section 20.6.2.3106 NMAC, in order for NMED to complete its technical evaluation of the application:

1. A list of exceedences of any ground water standard listed under Section 20.6.2.3103 NMAC over the past five (5) years for samples collected from the following wells: MCO-3, MCO-4B, MCO-5, MCO-6, MCO-7, MCO-9, MCOBT-4.4, R-13, R-14, R-15, and TW-8.
2. A list of detections of any of the toxic pollutants listed under Section 20.6.2.7.VV NMAC over the past five (5) years for samples collected from the following wells: MCO-3, MCO-4B, MCO-5, MCO-6, MCO-7, MCO-9, MCOBT-4.4, R-13, R-14, R-15, and TW-8.

Please submit the requested information within 45 days of the date of this letter. Your cooperation is appreciated. If you have any questions, please contact me at (505) 827-0078.

Sincerely,

Curt Frischkorn  
Ground Water Pollution Prevention Section

7002 2410 0004 2499 5283

**U.S. Postal Service**  
**CERTIFIED MAIL**  
(Domestic Mail Only; No Ins)

For delivery information visit us at [www.usps.com](http://www.usps.com)

**OFFICE**

Postage	\$
Certified Fee	
Return Receipt Fee (Endorsement Required)	
Restricted Delivery Fee (Endorsement Required)	
Postage & Fees	\$

**Steven R. Rae, Group Leader, Water, Quality & Hydrology Risk Reduction & Environmental Stewardship Division, Los Alamos National Laboratory, P.O. Box 1663, MS K497, Los Alamos, New Mexico 87545**

PS Form 3800, June 2002



APR 08 2004

*Risk Reduction & Environmental Stewardship Division  
Water Quality & Hydrology Group (RRES-WQH)*

P.O. Box 1663, Mail Stop K497  
Los Alamos, New Mexico 87545  
(505) 667-7969/FAX: (505) 665-9344

Date: April 5, 2004  
Refer to: RRES-WQH: 04-062

Mr. Curt Frischkorn  
Ground Water Pollution Prevention Section  
Ground Water Quality Bureau  
New Mexico Environment Department  
P.O. Box 26110  
Santa Fe, New Mexico 87502

**SUBJECT: REQUEST FOR ADDITIONAL INFORMATION, GROUND WATER  
DISCHARGE PLAN (DP-1132), TA-50 RADIOACTIVE LIQUID WASTE  
TREATMENT FACILITY**

Dear Mr. Frischkorn:

In your March 4, 2004, letter (copy enclosed) you requested additional information regarding Los Alamos National Laboratory's ground water discharge plan application (DP-1132) for the Radioactive Liquid Waste Treatment Facility (RLWTF) at Technical Area (TA)-50. Specifically, you asked for ground water quality data for 11 alluvial, intermediate, and regional aquifer wells in Mortandad Canyon. The three enclosed data tables provide the information requested. In addition, I have briefly discussed the data contained within each table below.

**Table 1.0. Detections of Inorganic Contaminants > NM WQCC Reg. 3103 Standards, 1999-2003.**

A query of the Laboratory's Water Quality Database (WQDB) for NM WQCC Regulation 3103 inorganic contaminants produced the results presented in Table 1.0. Twelve apparent exceedances for fluoride (F) and nitrate-N (NO<sub>3</sub>-N) occurred between 1999 and the third quarter of 2001. While not on your list, fluoride was detected at MCO-7.5 at 1.61 mg/L on 7/7/03, slightly above the standard of 1.6 mg/L. You should note that all exceedances occurred in alluvial aquifer wells, not in intermediate or regional wells.

No fluoride or nitrate-N exceedances have occurred since the 3<sup>rd</sup> quarter of 2001 due to the treatment upgrades (Tubular Ultrafilter and Reverse Osmosis Units) installed at the RLWTF in March 1999 and the resulting improvements in effluent quality. Figures 1.0 and 2.0 show nitrate+nitrite (as N) and fluoride concentrations from quarterly monitoring conducted at Mortandad Canyon alluvial wells MCO-3, MCO-6, and MCO-7 from 1998-2003. These data were reported to your bureau in the voluntary quarterly reports submitted by the Laboratory since the

first quarter of 1999. The overall trend of decreasing nitrate+nitrite (as N) and fluoride concentrations is coincident with the lower concentrations present in the RLWTF's effluent since March 1999; average effluent nitrate+nitrite (as N) concentrations in 2002 and 2003 were 1.54 mg/L and 1.23 mg/L, respectively, and average effluent fluoride concentrations in 2002 and 2003 were 0.46 mg/L and 0.33 mg/L, respectively.

There were three exceedances for iron (Fe). It should be noted that all three of the iron exceedances occurred in unfiltered samples (the NM WQCC ground water standard is for dissolved iron). Dissolved iron was measured in samples from these wells at concentrations below the standard.

**Table 2.0. Detections of NM WQCC Reg. 3103 Organic and Radiological Contaminants, 1999-2003.**

A query of the Laboratory's WQDB for NM WQCC Regulation 3103 organic and radiological contaminants produced the results presented in Table 2.0. None of the detections exceeded regulatory standards. It should be noted that two regulated contaminants, monomethylnaphthalene and Radium-226/Radium-228, were not analyzed for during this period. Ten of the 19 detections occurred in Quality Control (QC) samples; these results have been provided to illustrate the problem of false positive detections in organic samples. Two additional detections were invalidated due to the analytical laboratory finding blank contamination ("B" Flag). The table below presents the seven valid detections identified from the database query.

**Detections of WQCC 3103 Organics in Mortandad Canyon Ground Water Samples, '99-'03.**

Location	Sample Date	Analyte	Result (ug/L)	Lab Qualifier	GW Standard (ug/L)
MCO-5	8/02/01	Toluene	0.83	J	750
MCO-5	8/02/01	Xylene (Total)	0.64	J	620
MCO-5	8/02/01	Benzene	0.45	J	10
R-15	10/10/00	Toluene	0.69	J	750
TW-8	8/03/99	Methylene Chloride	2.2		100
TW-8	8/03/99	Methylene Chloride	2.5		100
TW-8	6/04/01	Methylene Chloride	1.1	J	100

Please note that methylene chloride and toluene were also found in equipment, field, and trip blanks, and are among several common analytical laboratory contaminants inadvertently introduced during organic analysis (Fetter 1993: C. W. Fetter, *Contaminant Hydrology* (Macmillan Publishing Co., New York, 1993), p. 334). Regarding toluene, from Longmire, "The occurrence of toluene at well R-15 is probably not related to petroleum products because of its single presence without benzene, ethylbenzene, and xylene isomers that are common constituents of gasoline and diesel fuel." (Longmire, P., March 2002. "Characterization Well R-15 Geochemistry Report," Los Alamos National Laboratory Report LA-13896-MS, Los Alamos, New Mexico, p. 13.).



The detection of benzene, xylene, and toluene at well MCO-5 on 8/02/01 may be related to the presence of gasoline vapors and/or exhaust fumes at the sampling site. This explanation is supported by the presence of ethylbenzene in a field trip blank (FTB) prepared for the sampling event (see Table 2.0). Well sampling at MCO-5 was conducted using a gas-powered air compressor. Gasoline vapors and/or exhaust fumes from the air compressor were potential sources of sample contamination. None of these contaminants have reappeared since 2001.

**Table 3.0. Detections of NM WQCC Toxic Pollutants and Other Non-Regulated Organic Contaminants, 1999-2003.**

A query of the Laboratory's WQDB for NM WQCC Toxic Pollutants (20.6.2.7.VV NMAC) and other non-regulated organic contaminants produced the results presented in Table 3.0. A list of NM WQCC regulated toxic pollutants not currently analyzed for by the Laboratory is presented in Table 4.0. Sixteen of the 23 detections occurred in QC samples. Two contaminants detected (octachlorodibenzofuran and acetone) are unregulated. The table below presents the five valid detections of NM WQCC Toxic Pollutants identified from the database query.

**Detections of WQCC Toxic Pollutants in Mortandad Canyon Ground Water Samples, '99-'03.**

Location	Sample Date	Analyte	Result (ug/L)	Lab Qualifier
MCO-3	5/01/02	Bis(2-ethylhexyl)phthalate	0.25	J
MCO-5	8/02/01	Xylene[1,2-]	0.19	J
MCO-5	8/02/01	Xylene[1,3-]+Xylene[1,4-]	0.45	J
R-15	2/24/00	Bis(2-ethylhexyl)phthalate	9.3	J
R-15	10/10/00	Bis(2-ethylhexyl)phthalate	5.9	J

Please note that bis(2-ethylhexyl)phthalate was found in equipment, field, and trip blanks, and is also among several common analytical laboratory contaminants inadvertently introduced during organic analysis (Fetter 1993). As indicated previously, the xylene detections at MCO-5 on 8/02/01 suggest sample contamination from gasoline vapors and/or exhaust fumes.

Please contact me at (505) 667-7969 if you have any questions regarding this information.

Sincerely,



Bob Beers  
Water Quality & Hydrology Group

BB/tml



Enclosure: a/s

Cy: C. Voorhees, NMED DOE/OB, Santa Fe, NM, w/enc.  
S. Yanicek, NMED DOE/OB, w/enc., MS J993  
J. Vozella, NNSA/LASO, w/enc., MS A316  
G. Turner, NNSA/LASO, w/enc., MS A316  
M. Johansen, NNSA/LASO, w/enc., MS A316  
J. Holt, ADO, w/enc., MS A104  
B. Stine, ADO, w/enc., MS A104  
T. Stanford, FWO-DO, w/enc., MS K492  
D. McLain, FWO-WFM, w/enc., MS J593  
R. Alexander, FWO-WFM, w/enc., MS J593  
D. Moss, FWO-WFM, w/enc., MS E518  
P. Worland, FWO-WFM, w/enc., MS E518  
B. Ramsey, RRES-DO, w/enc., MS J591  
K. Hargis, RRES-DO, w/enc., MS J591  
T. George, RRES-DO, w/enc., MS J591  
D. Stavert, RRES-EP, w/enc., MS J591  
C. Nylander, RRES-GP, w/enc., MS M992  
S. Rae, RRES-WQH, w/enc., MS K497  
D. Rogers, RRES-WQH, w/enc., MS K497  
P. Wardwell, LC-ESH, w/enc., MS A187  
RRES-WQH File, w/enc., MS K497  
IM-5, w/enc., MS A150





APR 08 2004

Table 1.0. Mortandad Canyon. Detections of Inorganic Contaminants > NM WQCC Regulation 3103 Groundwater Standards. 1999-2003.

Location Name	Sample Date	Analyte	Sample Type <sup>1</sup>	Field Prep <sup>1</sup>	Field QC Type <sup>1</sup>	Symbol	Result	Units	Lab Qualifier <sup>2</sup>	Validation Flag <sup>3</sup>	NM WQCC GW Standard <sup>4</sup> (mg/L)	Ratio of Result to Standard
MCO-3	04/16/99	F(-1)	CS	F			2.22	mg/L			1.6	1.39
MCO-3	07/08/03	Fe	DUP	UF			1.02	mg/L			1.0	1.02
MCO-5	04/14/99	NO3-N	CS	F			32.9	mg/L			10	3.29
MCO-7	04/13/99	F(-1)	CS	F			1.79	mg/L			1.6	1.12
MCO-7	10/30/00	F(-1)	CS	F			2.13	mg/L			1.6	1.33
MCO-7	03/12/01	F(-1)	CS	F			1.61	mg/L			1.6	1.01
MCO-7	05/24/01	F(-1)	CS	F			1.74	mg/L			1.6	1.09
MCO-7	08/07/01	F(-1)	CS	F			1.79	mg/L			1.6	1.12
MCO-7	09/10/01	F(-1)	CS	F			1.61	mg/L		J	1.6	1.01
MCO-7	06/06/02	Fe	CS	UF			1.14	mg/L			1.0	1.14
MCO-7	06/06/02	Fe	CS	UF			1.06	mg/L			1.0	1.06
MCO-7	04/13/99	NO3-N	CS	F			14.9	mg/L			10	1.49
MCO-7	02/24/00	NO3+NO2-N	CS	F			12.5	mg/L			10 <sup>5</sup>	1.25
MCO-7	04/17/00	NO3+NO2-N	CS	F			10.8	mg/L			10 <sup>5</sup>	1.08
MCO-7	08/07/01	NO3+NO2-N	CS	F			10.9	mg/L			10 <sup>5</sup>	1.09

**Notes:**

- <sup>1</sup>Codes: UF-unfiltered, F-filtered, CS-customer sample, DUP-laboratory duplicate, FTB-trip blank, EQB-equipment blank, FB-field blank
- <sup>2</sup>Lab qualifier codes: J means the associated numerical value is an estimated quantity. B means the analyte was present in the blank and the sample.
- <sup>3</sup>Validation qualifier codes: J means the analyte is classified as detected, but the reported concentration is expected to be more uncertain than usual.
- <sup>4</sup>These standards apply to the dissolved portion of the contaminants specified.
- <sup>5</sup>Standard is for NO3-N.

02335

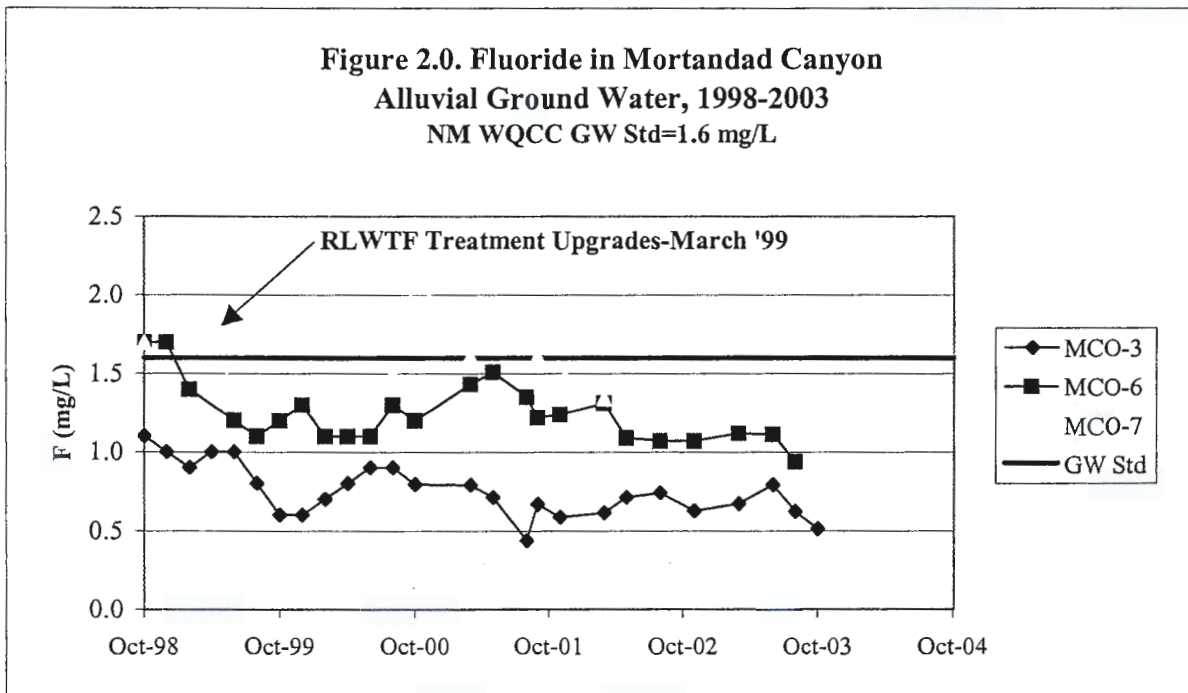
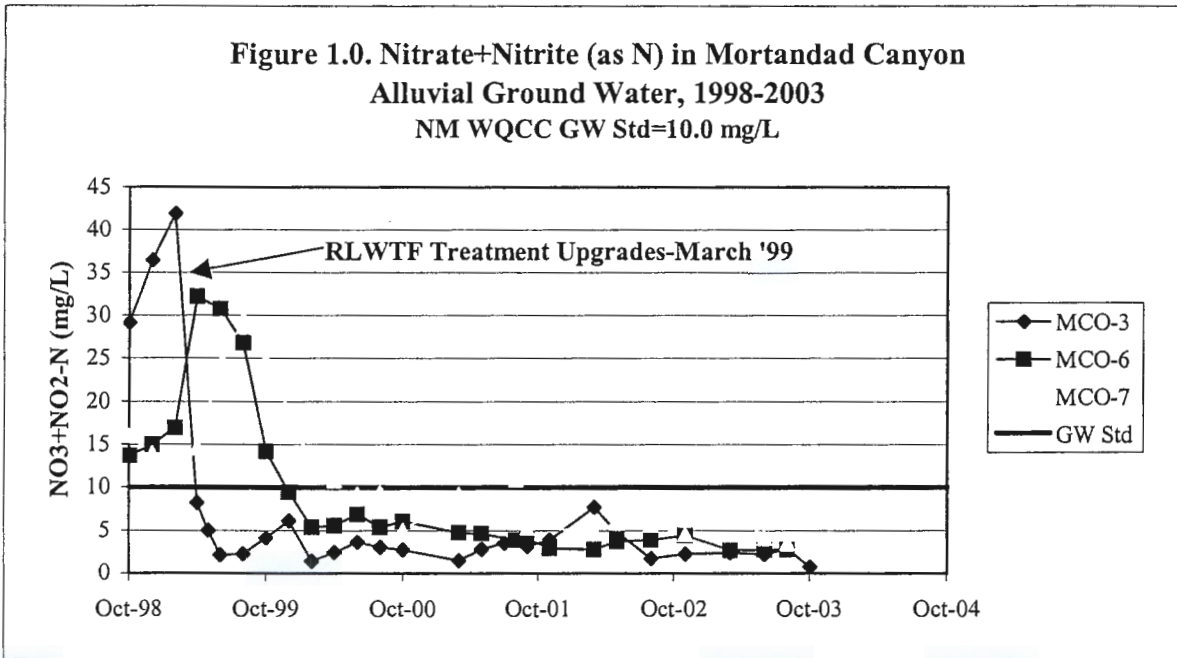

Radioactive Liquid Waste Treatment Facility  
 Groundwater Discharge Plan (DP-1132)  
 Request for Additional Information  
 March, 2004

4/5/2004

Table 2.0. Mortandad Canyon. Detections of NM WQCC Regulation 3103 Organic Contaminants. 1999-2003.

Location Name	Sample Date	Analyte	CAS #	Analytical Suite	Sample Type <sup>1</sup>	Field Prep <sup>1</sup>	Field QC Type <sup>1</sup>	Symbol	Result	Units	Lab Qualifier <sup>2</sup>	Validation Flag <sup>3</sup>	NM WQCC GW Standard <sup>4</sup> (ug/L)	Ratio of Result to Standard
MCO-4B	06/30/03	Toluene	108-88-3	VOA	CS	UF	FTB		1	ug/L			750	0.0013
MCO-5	08/02/01	Ethylbenzene	100-41-4	VOA	CS	UF	FTB		0.18	ug/L	J		750	0.0002
MCO-5	08/02/01	Toluene	108-88-3	VOA	CS	UF			0.83	ug/L	J		750	0.0011
MCO-5	08/02/01	Xylene (Total)	1330-20-7	VOA	CS	UF			0.64	ug/L	J		620	0.0010
MCO-5	08/02/01	Benzene	71-43-2	VOA	CS	UF			0.45	ug/L	J		10	0.0450
MCO-6	04/05/02	Ethylbenzene	100-41-4	VOA	CS	UF	FTB		0.25	ug/L	J		750	0.0003
MCO-6	04/05/02	Toluene	108-88-3	VOA	CS	UF	EQB		0.31	ug/L	J		750	0.0004
MCO-6	04/05/02	Toluene	108-88-3	VOA	CS	UF	FTB		0.26	ug/L	J		750	0.0003
MCO-6	04/05/02	Methylene Chloride	75-09-2	VOA	CS	UF	EQB		0.37	ug/L	J		100	0.0037
MCO-6	04/05/02	Methylene Chloride	75-09-2	VOA	CS	UF	FTB		0.49	ug/L	J		100	0.0049
R-15	10/10/00	Toluene	108-88-3	VOA	CS	UF			0.69	ug/L	J	J	750	0.0009
TW-8	08/03/99	Methylene Chloride	75-09-2	VOA	CS	UF			2.2	ug/L			100	0.0220
TW-8	08/03/99	Methylene Chloride	75-09-2	VOA	CS	UF			2.5	ug/L			100	0.0250
TW-8	06/04/01	Toluene	108-88-3	VOA	CS	UF	FB		0.56	ug/L	BJ		750	0.0007
TW-8	06/04/01	Toluene	108-88-3	VOA	CS	UF			0.3	ug/L	BJ		750	0.0004
TW-8	06/04/01	Methylene Chloride	75-09-2	VOA	CS	UF	FB		0.73	ug/L	J		100	0.0073
TW-8	06/04/01	Methylene Chloride	75-09-2	VOA	CS	UF			1.1	ug/L	J		100	0.0110
TW-8	06/04/01	Naphthalene	91-20-3	VOA	CS	UF	FB		0.29	ug/L	BJ		30	0.0097
TW-8	06/04/01	Naphthalene	91-20-3	VOA	CS	UF			0.37	ug/L	BJ		30	0.0123

Notes:

<sup>1</sup>Codes: UF-unfiltered, F-filtered, CS-customer sample, DUP-laboratory duplicate, FTB-trip blank, EQB-equipment blank, FB-field blank

<sup>2</sup>Lab qualifier codes: J means the associated numerical value is an estimated quantity. B means the analyte was present in the blank and the sample.

<sup>3</sup>Validation qualifier codes: J means the analyte is classified as detected, but the reported concentration is expected to be more uncertain than usual.

<sup>4</sup>These standards apply to the dissolved portion of the contaminants specified.

02337

Table 3.0. Mortandad Canyon. Detections of NM WQCC Toxic Pollutants and Other Unregulated Organic Contaminants. 1999-2003.

Location Name	Sample Date	Analyte	CAS#	Analytical Suite	Sample Type <sup>1</sup>	Field Prep <sup>1</sup>	Field QC Type <sup>1</sup>	Symbol	Result	Units	Lab Qualifier <sup>2</sup>	Validation Flag <sup>3</sup>	NM WQCC Toxic Pollutant? (Y/N)
MCO-3	05/01/02	Bis(2-ethylhexyl)phthalate	117-81-7	SVOA	CS	UF			0.25	ug/L	J		Y
MCO-4B	03/18/02	Bis(2-ethylhexyl)phthalate	117-81-7	SVOA	CS	UF	EQB		0.47	ug/L	J	J	Y
MCO-5	07/07/00	Octachlorodibenzofuran	39001-02-0	SVOA	CS	UF			1.8E-05	ug/L			N
MCO-5	08/02/01	Xylene[1,2-]	95-47-6	VOA	CS	UF			0.19	ug/L	J		Y
MCO-5	08/02/01	Xylene[1,3-]+Xylene[1,4-]		VOA	CS	UF			0.45	ug/L	J		Y
MCO-5	03/18/02	Bis(2-ethylhexyl)phthalate	117-81-7	SVOA	CS	UF	EQB		0.59	ug/L	J	J	Y
MCO-5	05/30/02	Dichlorobenzene[1,4-]	106-46-7	VOA	CS	UF	FTB		0.47	ug/L	J		Y
MCO-6	03/19/02	Bis(2-ethylhexyl)phthalate	117-81-7	SVOA	CS	UF	EQB		0.62	ug/L	J	J	Y
MCO-6	04/05/02	Dichlorobenzene[1,4-]	106-46-7	VOA	CS	UF	EQB		0.27	ug/L	BJ		Y
MCO-6	04/05/02	Dichlorobenzene[1,4-]	106-46-7	VOA	CS	UF	FTB		0.33	ug/L	BJ		Y
MCO-6	04/05/02	Methyl-2-pentanone[4-]	108-10-1	VOA	CS	UF	EQB		1.3	ug/L	J		N
MCO-6	04/05/02	Bis(2-ethylhexyl)phthalate	117-81-7	SVOA	CS	UF	EQB		0.76	ug/L	BJ		Y
MCO-6	04/05/02	Hexanone[2-]	591-78-6	VOA	CS	UF	EQB		1.2	ug/L	J		N
MCO-6	04/05/02	Acetone	67-64-1	VOA	CS	UF	EQB		4.9	ug/L	J		N
MCO-6	04/05/02	Acetone	67-64-1	VOA	CS	UF	FTB		3.6	ug/L	J		N
MCO-7	03/19/02	Bis(2-ethylhexyl)phthalate	117-81-7	SVOA	CS	UF	EQB		0.36	ug/L	J	J	Y
MCO-7	06/06/02	Dichlorobenzene[1,4-]	106-46-7	VOA	CS	UF	FTB		0.46	ug/L	J		Y
R-15	02/24/00	Bis(2-ethylhexyl)phthalate	117-81-7	SVOA	CS	UF			9.3	ug/L	J	J	Y
R-15	02/24/00	Acetone	67-64-1	VOA	CS	UF			19	ug/L	J	J	N
R-15	10/10/00	Bis(2-ethylhexyl)phthalate	117-81-7	SVOA	CS	UF			5.9	ug/L	J	J	Y
TW-8	06/04/01	Carbon Disulfide	75-15-0	VOA	CS	UF	FB		2.5	ug/L	J		N
TW-8	06/04/01	Butanone[2-]	78-93-3	VOA	CS	UF	FB		5.3	ug/L			N
TW-8	08/21/02	Dichlorobenzene[1,2-]	95-50-1	SVOA	CS	UF	EQB		1.8	ug/L	J	J	Y

Notes:

<sup>1</sup>Codes: UF-unfiltered, F-filtered, CS-customer sample, DUP-laboratory duplicate, FTB-trip blank, EQB-equipment blank, FB-field blank

<sup>2</sup>Lab qualifier codes: J means the associated numerical value is an estimated quantity. B means the analyte was present in the blank and the sample.

<sup>3</sup>Validation qualifier codes: J means the analyte is classified as detected, but the reported concentration is expected to be more uncertain than usual.

**Table 4.0. NM WQCC Toxic Pollutants Not Currently Analyzed For By The Laboratory**

<u>Contaminant</u>	<u>CAS Number</u>
aldrin	309-00-2
chlordan	57-74-9
pentachlorobenzene	608-93-5
1,2,4,5 tetrachlorobenzene	95-94-3
bis (2-chloroisopropyl) ether	39638-32-9
bis (chloromethyl) ether	542-88-1
DDT	50-29-3
dieldrin	60-57-1
diphenylhydrazine	38622-18-3
endosulfan	115-29-7
endrin	72-20-8
dichloromethane	75-9-2
heptachlor	76-44-8
hexachlorocyclohexane (HCH)	
alpha-HCH	6108-11-8
beta-HCH	6108-12-9
gamma-HCH	6108-13-0
technical HCH	608-73-1
N-nitrosodiethylamine	55-18-5
N-nitrosodibutylamine	924-16-3
N-nitrosodiphenylamine	86-30-6
N-nitrosopyrrolidine	930-55-2
toxaphene	8001-35-2
cis-1,2-dichloroethylene	156-59-2



BILL RICHARDSON  
GOVERNOR

*State of New Mexico*  
**ENVIRONMENT DEPARTMENT**

*Ground Water Quality Bureau*  
*Harold Runnels Building*  
1190 St. Francis Drive, P.O. Box 26110  
Santa Fe, New Mexico 87502-6110  
Telephone (505) 827-2918  
Fax (505) 827-2965



RON CURRY  
SECRETARY

DERRITH WATCHMAN-M  
DEPUTY SECRETARY

**CERTIFIED MAIL – RETURN RECEIPT REQUESTED**

March 4, 2004

Steven R. Rae, Group Leader  
Water Quality and Hydrology Group  
Risk Reduction and Environmental Stewardship Division  
Los Alamos National Laboratory  
P.O. Box 1663, MS K497  
(RRES-WQH)  
Los Alamos, New Mexico 87545

**RE: Request for Additional Information, DP-1132, Los Alamos National Laboratory**

Dear Mr. Rae:

The New Mexico Environment Department (NMED) has reviewed the application for the above referenced facility in accordance with the New Mexico Water Quality Control Commission Regulations (20.6.2 NMAC). The following additional information is necessary, pursuant to Section 20.6.2.3106 NMAC, in order for NMED to complete its technical evaluation of the application:

1. A list of exceedences of any ground water standard listed under Section 20.6.2.3103 NMAC over the past five (5) years for samples collected from the following wells: MCO-3, MCO-4B, MCO-5, MCO-6, MCO-7, MCO-9, MCOBT-4.4, R-13, R-14, R-15, and TW-8.
2. A list of detections of any of the toxic pollutants listed under Section 20.6.2.7.VV NMAC over the past five (5) years for samples collected from the following wells: MCO-3, MCO-4B, MCO-5, MCO-6, MCO-7, MCO-9, MCOBT-4.4, R-13, R-14, R-15, and TW-8.

Please submit the requested information within 45 days of the date of this letter. Your cooperation is appreciated. If you have any questions, please contact me at (505) 827-0078.

Sincerely,

Curt Frischkorn  
Ground Water Pollution Prevention Section



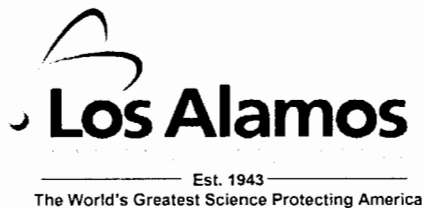

*Risk Reduction & Environmental Stewardship Division  
Water Quality & Hydrology Group (RRES-WQH)*  
P.O. Box 1663, Mail Stop K497  
Los Alamos, New Mexico 87545  
(505) 667-7969/FAX: (505) 665-9344

Date: April 20, 2004  
Refer to: RRES-WQH: 04-068

Mr. Curt Frischkorn  
Pollution Prevention Section  
Ground Water Quality Bureau  
New Mexico Environment Department  
P.O. Box 26110  
Santa Fe, New Mexico 87502

**SUBJECT: RLWTF ANNUAL REPORT FOR 2003**

Dear Mr. Frischkorn:

Please find enclosed the following Los Alamos National Laboratory report: *RLWTF Annual Report for 2003* (LA-CP-04-0314, March 2004). This report is being provided to your agency as supporting documentation for the Laboratory's Ground Water Discharge Plan Application (DP-1132) for the Radioactive Liquid Waste Treatment Facility (RLWTF) at Technical Area (TA)-50.

The *RLWTF Annual Report for 2003* contains summary information about flows, concentrations, and quantities received and discharged at the three facilities used to treat radioactive liquid wastes (TA-50, TA-21, and TA-53).

Please note that this document is a Los Alamos National Laboratory Controlled Publication. Distribution of this document is limited and dissemination of any information contained within this document is prohibited without prior approval from Los Alamos National Laboratory.

Please contact me at 667-7969 should you have any questions or concerns regarding this report.

Sincerely,

Bob Beers  
Water Quality & Hydrology Group

BB/lm



Enclosure: a/s

Cy: M. Leavitt, NMED/SWQB, Santa Fe, NM, w/o enc.  
C. Voorhees, NMED/DOE/OB, Santa Fe, NM, w/o enc.  
R. Ford-Schmid, NMED/DOE/OB, Santa Fe, NM, w/o enc.  
J. Vozella, NNSA/LASO, w/o enc., MS A316  
G. Turner, NNSA/LASO, w/o enc., MS A316  
M. Johansen, NNSA/LASO, w/o enc., MS A316  
J. Holt, ADO, w/o enc., MS A104  
T. Stanford, FWO-DO, w/o enc., MS K492  
D. McLain, FWO-WFM, w/o enc., MS J593  
R. Alexander, FWO-WFM, w/o enc., MS J593  
D. Moss, FWO-WFM, w/o enc., MS E518  
B. Ramsey, RRES-DO, w/o enc., MS J591  
K. Hargis, RRES-DO, w/o enc., MS J591  
T. George, RRES-DO, w/o enc., MS J591  
D. Stavert, RRES-EP, w/o enc., MS J591  
C. Nylander, RRES-GP, w/o enc., MS M992  
S. Rae, RRES-WQH, w/o enc., MS K497  
D. Rogers, RRES-WQH, w/o enc., MS K597  
M. Saladen, RRES-WQH, w/o enc., MS K497  
RRES-WQH File, w/enc., MS K497  
IM-5, w/enc., MS A150

LA-CP-04-0314

Los Alamos Controlled Publication;  
distribution is limited.

Title: RLWTF Annual Report for 2003

Author(s): Ruth Watkins, FWO-IIM  
Pete Worland, FWO-WFM

Submitted to: Facility and Waste Operations Division  
March 2004

DISTRIBUTION LIMITATION STATEMENT

Further dissemination authorized to U.S. Government agencies and their contractors; other requests shall be approved by the originating facility or higher DOE programmatic authority.



Los Alamos National Laboratory, an affirmative action/equal opportunity employer, is operated by the University of California for the U.S. Department of Energy under contract W-7405-ENG-36. By acceptance of this article, the publisher recognizes that the U.S. Government retains a nonexclusive, royalty-free license to publish or reproduce the published form of this contribution, or to allow others to do so, for U.S. Government purposes. Los Alamos National Laboratory requests that the publisher identify this article as work performed under the auspices of the U.S. Department of Energy. Los Alamos National Laboratory strongly supports academic freedom and a researcher's right to publish; as an institution, however, the Laboratory does not endorse the viewpoint of a publication or guarantee its technical correctness.

Form 1756c (10/98)

OFFICIAL USE ONLY

: 02344

AR-RLW-2003

# RLWTF Annual Report for 2003

Effective Date: 4-12-04

Controlled Distribution Date: NA

Next Review Date: NA

	Signature	Date
<b>Report Preparation</b>		
Ruth Watkins, FWO-IIM	<i>Ruth Watkins</i>	04-06-04
<b>Reviewer/Process Engineer</b>		
Pete Worland, FWO-WFM	<i>Pete Worland</i>	4/6/04
<b>Facility &amp; Operations Team Lead</b>		
Wm. David Moss, FWO-WFM	<i>Wm David Moss</i>	04/06/04
<b>Facility Manager/Group Leader</b>		
Dennis McLain, FWO-WFM	<i>Dennis McLain</i>	4/12/04

## Table of Contents

Acronyms and Abbreviations.....	5
1. Overview of CY 2003 Activities at the TA-50 RLWTF, the TA-21 RLWTF and the TA-53 RLWTF.....	6
2. Summary of the TA-50 RLWTF Treatment Operations During CY 2003 .....	7
3. TA-50 RLWTF Influent and Effluent Flows in CY 2003.....	12
4. Radiological Nature of the CY 2003 TA-50 RLWTF Influent and Effluent Waters and Process Waste Sludge .....	15
5. Non-Radiological Nature of the CY 2003 TA-50 RLWTF Influent and Effluent Waters and Process Waste Sludge .....	30
6. Summary of CY 2003 Operations at the TA-21 RLWTF .....	48
7. Summary of CY 2003 Operations at the TA-53 RLWTF .....	51
Appendix A: TA-50 RLWTF Monthly Flow Summary for CY 2003 .....	52-54
Appendix B: TA-50 RLWTF Daily Flow Summary for CY 2003 .....	55-67
Appendix C: TA-50 RLWTF Monthly Radioisotope Summary for CY 2003 .....	68-80
Appendix D: TA-50 RLWTF Monthly Mineral Summary for CY 2003 .....	81-93
Appendix E: CY 2003 RLWTF Feed VOC Results by Sample .....	94-99
Appendix F: CY 2003 RLWTF Feed VOC Results by Species .....	100-105
Appendix G: CY 2003 RLWTF Feed SVOC Results by Sample.....	106-110
Appendix H: CY 2003 RLWTF Feed SVOC Results by Species .....	111-115
Appendix I: CY 2003 RLWTF Sludge VOC Results by Sample.....	116-118
Appendix J: CY 2003 RLWTF Sludge VOC Results by Species.....	119-121
Appendix K: CY 2003 RLWTF Sludge SVOC Results by Sample .....	122-123
Appendix L: CY 2003 RLWTF Sludge SVOC Results by Species .....	124-125

### List of Figures

3-1	TA-50 Annual Discharge Volumes (1963 – 2003) .....	14
4-1	Twelve Month Flow Weighted Sum of Ratios of the TA-50 RLWTF Effluent During CY 2003 (DOE Order 5400.5).....	19
4-2	Gross Alpha Activity in the RLWTF Influent and Effluent During CY 2003 .....	22
4-3	Pu-238 Activity in the RLWTF Influent and Effluent During CY 2003 .....	23
4-4	Pu-239 Activity in the RLWTF Influent and Effluent During CY 2003 .....	24
4-5	Am-241 Activity in the RLWTF Influent and Effluent During CY 2003 .....	25
4-6	Gross Beta Activity in the RLWTF Influent and Effluent During CY 2003 .....	26
4-7	Sr-90 Activity in the RLWTF Influent and Effluent During CY 2003 .....	27
4-8	H-3 and Sr-89 Activity in the RLWTF Influent and Effluent During CY 2003 .....	28
5-1	Silicon and TDS in the RLWTF Influent and Effluent During CY 2003.....	36
5-2	Potassium and Sodium in the RLWTF Influent and Effluent During CY 2003.....	37
5-3	COD and Calcium in the RLWTF Influent and Effluent During CY 2003 .....	38
5-4	Iron in the RLWTF Influent and Effluent During CY 2003.....	39
5-5	Mercury in the RLWTF Influent and Effluent During CY 2003 .....	40
5-6	Zinc and Fluoride in the RLWTF Influent and Effluent During CY 2003.....	42
5-7	Perchlorate and Total Alkalinity in the RLWTF Influent and Effluent During CY 2003 .....	43
5-8	Ammonia-Nitrogen and Nitrate-Nitrogen in the RLWTF Influent and Effluent During CY 2003 .....	44

**List of Tables**

2-1	Summary of TA-50 RLWTF Operations During CY 2003 .....	8-11
3-1	Effluent Discharge Information for the RLWTF During CY 2003 .....	12
3-2	TA-50 RLWTF Flow Summary During CY 2003 .....	13
4-1	Mass of Alpha Emitting Radionuclides in the RLWTF Influent and Effluent During CY 2003 .....	15
4-2	Radionuclide Analyses of the RLWTF Influent and Effluent in CY 2003 .....	16
4-3	TA-50 RLWTF Gross Alpha Removal in CY 2003 .....	17
4-4	TA-50 RLWTF Radionuclide Summary in CY 2003 .....	18
4-5	TA-50 RLWTF Effluent Compared with DOE Order 5400.5 in CY 2003 .....	20
4-6	TA-50 RLWTF Vacuum Filter Sludge Drums Shipped During CY 2003 .....	29
5-1	NPDES and NMED Discharge Parameters .....	30
5-2	Discharge Limits for NPDES and NMED Parameters in the RLWTF Effluent	31
5-3	TA-50 RLWTF Effluent Compared to NPDES and NMED Standards During CY 2003 .....	33
5-4	TA-50 RLWTF Mineral Summary for CY 2003.....	34
5-5	VOC/SVOC Detected in Weekly Samples of 2003 RLWTF Influent .....	45-46
5-6	VOC/SVOC Detected in Monthly Samples of 2003 RLWTF Effluent .....	46
5-7	VOC/SVOC Detected in Samples of 2003 RLWTF Sludge .....	47
6-1	Radioisotopes in August 2003 Sample of TA-21 Influent .....	49
6-2	Minerals in August 2003 Sample of TA-21 Influent.....	50

### Acronyms and Abbreviations

Ci	curie ( $3.7 \times 10^{10}$ disintegrations per second)
CL	clarifier treatment by addition of ferric sulfate, lime and polymer
COD	chemical oxygen demand
CUF	centrifugal ultrafilter
CY	calendar year
DCG	derived concentration guidelines
DOE	United States Department of Energy
EDR	electrodialysis reversal
Final50	composite sample of effluent from the RLWTF
IO	influent oxidation by permanganate addition
IX	ion exchange
Kg	kilogram
L	liter
LANL	Los Alamos National Laboratory
LDL	less than detection limit
meq/L	milliequivalents per liter
mg/L	milligram per liter
mrem	millirem ( $10^{-3}$ rem)
$\mu$ S/cm	microSiemens per centimeter
nCi/L	nanocuries per liter ( $10^{-9}$ curies per liter)
NMED	New Mexico Environment Department
NMWQCC	New Mexico Water Quality Control Commission
NPDES	National Pollutant Discharge Elimination System
pCi/L	picocuries per liter ( $10^{-12}$ curies per liter)
Pu-239	plutonium isotope with atomic weight of 239
Raw50	composite sample of daily influent to RLWTF via the RLWCS
RLW	radioactive liquid waste
RLWCS	radioactive liquid waste collection system
RLWTF	radioactive liquid waste treatment facility
RLWTP	radioactive liquid waste treatment plant
RO	reverse osmosis
SF	sand filtration treatment of clarifier effluent
SVOC	semi-volatile organic chemical(s)
TA	technical area
TDS	total dissolved solids
TDS-E	total dissolved solids by electrical conductivity
TUF	tubular ultrafilter
VF	vacuum filtration of clarifier sludge
VOC	volatile organic chemical(s)
WETF	Weapons Engineering Tritium Facility

## 1. Overview of CY 2003 Activities at the TA-50 RLWTF, the TA-21 RLWTF and the TA-53 RLWTF

Los Alamos National Laboratory (LANL) has three facilities for the treatment of radioactive liquid wastes (RLW). Most radioactive liquid wastes are treated at the Technical Area 50 (TA-50) radioactive liquid waste treatment facility (RLWTF). The other two facilities are located at TA-21 and TA-53. During 2003, the TA-50 RLWTF received 12.16 million liters of RLW. The TA-21 and TA-53 facilities received 32,480 and 383,825 liters of RLW during 2003, respectively.

Authorization to discharge effluent water from the TA-50 RLWTF is regulated by the United States Environmental Protection Agency (USEPA) under the National Pollutant Discharge Elimination System (NPDES). The NPDES permit number is NM0028355. The TA-50 RLWTF effluent, for the 4<sup>th</sup> consecutive year, was in compliance with all twenty-one (21) NPDES water quality parameters during calendar year (CY) 2003.

LANL also has a voluntary commitment with the New Mexico Environment Department (NMED) to not discharge effluent from the TA-50 RLWTF that exceeds groundwater standards set by the New Mexico Water Quality Control Commission (NMWQCC) for three (3) water quality parameters: fluoride, nitrate-nitrogen and total dissolved solids (TDS). Two (2) weekly composite samples of RLWTF effluent slightly exceeded the NMED groundwater standard for fluoride of 1.6 mg/L (sample values were 2.07 mg/L and 1.64 mg/L). Each effluent tank is now analyzed for fluoride prior to discharge to ensure that the voluntary commitment is not exceeded again.

Additionally, the TA-50 RLWTF effluent must meet the guidelines of the United States Department of Energy (USDOE) Order 5400.5, "Radiation Protection of the Public and the Environment". During 2003, the RLWTF effluent was in compliance with these guidelines for the 4<sup>th</sup> consecutive year.

During calendar year 2003, the TA-50 RLWTF activities resulted in the disposal of 21,432 kilograms (29 cubic meters) of low-level radioactive dewatered sludge from the rotary vacuum filter. Additionally in 2003, 1,876,913 liters of secondary liquid waste from the main plant operation was volume reduced by the evaporator. The 135,125 liters of evaporator bottoms generated by this evaporation process were trucked to Tennessee for drying and solidification.

Processing challenges at the TA-50 RLWTF in the year 2003 were:

- Waste acceptance criteria (WAC) exceedances challenged the ability of the RLWTF low level waste processes to make dischargeable quality effluent water (high gross alpha influent in April and high chemical oxygen demand waters in May and September). Retreatment of large volumes of water resulted from these WAC exceedance events.
- Increased production of secondary waste volume resulted from the retreatment of the waste caused by the WAC exceedance events.
- Increased production of secondary waste volume also resulted from the decision in early April to produce only effluent water that had received RO treatment.



- RLWTF influent and process tanks were extremely full during the months of June and October due to increased production of secondary waste (as mentioned above), the need to retreat water (as mentioned above) and also due to the EDR going out of service in mid-April.
- Additional volumes and increased concentration of waste from the TA-55 MOX program beginning in March.

Besides regular plant operations, several significant operational activities occurred in 2003:

- Two evaporator campaigns occurred during June-July and October-November.
- Sludge was removed from the single walled concrete WM-2 sludge tank to minimize potential environmental impacts.
- Conversion of the RLWTF supervisory control and data acquisition software from Gensym G2 to Rockwell RS View software.
- Contamination issues in structure WM-201 exist due to the leaking caustic line from TA-55.
- The detection of the leak in September in the WM-66 caustic storage tank.
- Pilot testing of the seawater reverse osmosis technology for concentrating the RLWTF secondary waste stream.
- Pilot testing ion exchange for removal of soluble species from tubular ultrafilter and reverse osmosis permeate.
- Bench scale testing of Room 60 treatment improvements by pH modification and filtration.

Two major facility changes occurred during 2003:

- Siting of project management and construction trailers and installation of underground power lines for the anticipated construction of the Cerro Grande Rehabilitation Project (CGRP) tank farm.
- WM-2 pumphouse reconfiguration and connection to the cross-country line for the discharge of RLWTF effluent to Mortandad Canyon.

## **2. Summary of the TA-50 RLWTF Treatment Operations During CY 2003**

The following table, Table 2-1, summarizes on a monthly basis the significant operational information that occurred at the TA-50 RLWTF during the 2003 calendar year. Included in each month's summary are the unit operations that were used, what pilot testing was being performed, significant off-spec influent events, evaporator campaigns, and other events that significantly affected operations.

Table 2-1 Summary of TA-50 RLWTF Operations During CY 2003	
<b>January</b>	<ul style="list-style-type: none"> <li>- Normal operations included: IO, CL, SF, VF, TUF, IX, RO, EDR (influent oxidation, clarifier, sand filter, vacuum filtration, tubular ultrafilter, ion exchange, reverse osmosis, EDR)</li> <li>- Pilot testing: seawater RO in Room 116</li> <li>- Contamination issues continued in WM-201 as a result of the leak in the caustic line from TA-55</li> <li>- The RLWTF started out the new year with the 100K influent tank 80% full of tapwater that came to the plant on Christmas eve and Christmas day 2002. A valve failure at TA-48 allowed this water into the radioactive liquid waste collection system</li> </ul>
<b>February</b>	<ul style="list-style-type: none"> <li>- Normal operations included: IO, CL, SF, VF, TUF, IX, RO, EDR</li> <li>- Additional operations: trucked evaporator bottoms to TN</li> <li>- Pilot testing: seawater RO in Room 116</li> <li>- Contamination issues continued in WM-201 as a result of the leak in the caustic line from TA-55</li> </ul>
<b>March</b>	<ul style="list-style-type: none"> <li>- Normal operations included: IO, CL, SF, VF, TUF, CUF, IX, RO, EDR</li> <li>- Additional operations: <ul style="list-style-type: none"> <li>▪ WM-2 sludge tank effort began</li> <li>▪ Began treating MOX waste from TA-55</li> </ul> </li> <li>- Pilot testing: seawater RO in Room 116</li> <li>- Contamination issues continued in WM-201 as a result of the leak in the caustic line from TA-55</li> <li>- High gross alpha events mid-month</li> <li>- IX began to load with gross alpha</li> <li>- Identified that old discharge line to Mortandad Canyon and leaking valves in pumphouse were contaminating plant effluent water</li> </ul>
<b>April</b>	<ul style="list-style-type: none"> <li>- Normal operations included: IO, CL, SF, VF, TUF, CUF, IX, RO, EDR</li> <li>- Additional operations: <ul style="list-style-type: none"> <li>▪ WM-2 sludge tank effort continued</li> <li>▪ MOX waste treatment continued</li> <li>▪ Brought into service new IX vessels</li> <li>▪ Installed new RO membranes</li> <li>▪ EDR out of service mid-month</li> </ul> </li> <li>- Pilot testing: seawater RO in Room 116</li> <li>- Began discharging only RO permeate</li> <li>- Contamination issues continued in WM-201 as a result of the leak in the caustic line from TA-55</li> <li>- High gross alpha events mid-month</li> <li>- IX loading with gross alpha</li> <li>- Elevated fluoride concentrations in influent</li> <li>- Design began for modification of discharge line to Mortandad Canyon and leaking valves in pumphouse to eliminate contamination of plant effluent water</li> </ul>

Table 2-1 Summary of TA-50 RLWTF Operations During CY 2003	
<b>May</b>	<ul style="list-style-type: none"> <li>- Normal operations included: IO, CL, SF, VF, TUF, CUF, IX, RO</li> <li>- Additional operations:                             <ul style="list-style-type: none"> <li>▪ WM-2 sludge tank effort completed</li> <li>▪ MOX waste treatment continued</li> <li>▪ Retreatment of water required due to high COD</li> <li>▪ Evaporator run begins</li> </ul> </li> <li>- Pilot testing: seawater RO in Room 116</li> <li>- Continued to discharge only RO permeate</li> <li>- Contamination issues continued in WM-201 as a result of the leak in the caustic line from TA-55</li> <li>- High gross alpha events early in the month</li> <li>- IX loading with gross alpha</li> <li>- Elevated COD (not from TA-55) concentrations in influent; odor detected in CL-1</li> <li>- Design continued for modification of discharge line to Mortandad Canyon and leaking valves in pumphouse to eliminate contamination of plant effluent water</li> </ul>
<b>June</b>	<ul style="list-style-type: none"> <li>- Normal operations included: IO, CL, SF, VF, TUF, IX, RO</li> <li>- Additional operations:                             <ul style="list-style-type: none"> <li>▪ MOX waste treatment continued</li> <li>▪ Influent tanks very full due to retreatment of water required because of high COD in influent</li> <li>▪ Evaporator run continued</li> </ul> </li> <li>- Pilot testing: seawater RO in Room 116</li> <li>- Continued to discharge only RO permeate</li> <li>- Contamination issues continued in WM-201 as a result of the leak in the caustic line from TA-55</li> <li>- High gross alpha events mid-month</li> <li>- IX loading with gross alpha</li> <li>- Putrid odor detected in CL-1 due to high COD event in May; H<sub>2</sub>S in evaporator distillate</li> <li>- Design continued for modification of discharge line to Mortandad Canyon and leaking valves in pumphouse to eliminate contamination of plant effluent water</li> </ul>

Table 2-1 Summary of TA-50 RLWTF Operations During CY 2003	
<b>July</b>	<ul style="list-style-type: none"> <li>- Normal operations included: IO, CL, SF, VF, TUF, CUF, IX, RO</li> <li>- Additional operations:               <ul style="list-style-type: none"> <li>▪ MOX waste treatment continued</li> <li>▪ Evaporator run completed</li> </ul> </li> <li>- Pilot testing: seawater RO in Room 116</li> <li>- Continued to discharge only RO permeate</li> <li>- Contamination issues continued in WM-201 as a result of the leak in the caustic line from TA-55</li> <li>- High gross alpha events mid-month</li> <li>- Putrid odor detected in CL-1 due to high COD event in May; H<sub>2</sub>S in evaporator distillate</li> <li>- Connection to cross-country discharge line to Mortandad Canyon and isolation of leaking valves in pumphouse to eliminate contamination of plant effluent water</li> </ul>
<b>August</b>	<ul style="list-style-type: none"> <li>- Normal operations included: IO, CL, SF, VF, TUF, CUF, IX, RO</li> <li>- Additional operations:               <ul style="list-style-type: none"> <li>▪ MOX waste treatment continued</li> </ul> </li> <li>- Pilot testing: seawater RO in Room 116</li> <li>- Continued to discharge only RO permeate</li> <li>- Contamination issues continued in WM-201 as a result of the leak in the caustic line from TA-55</li> <li>- Began use of the cross-country discharge line to Mortandad Canyon to eliminate contamination of plant effluent water</li> </ul>
<b>September</b>	<ul style="list-style-type: none"> <li>- Normal operations included: IO, CL, SF, VF, TUF, CUF, IX, RO</li> <li>- Additional operations:               <ul style="list-style-type: none"> <li>▪ MOX waste treatment continued</li> <li>▪ Accepted initial treated foam waste from DARHT</li> <li>▪ Retreatment of water due to high COD in influent</li> <li>▪ Evaporator campaign began</li> </ul> </li> <li>- Pilot testing:               <ul style="list-style-type: none"> <li>▪ Seawater RO in Room 116</li> <li>▪ Ion exchange treatment of TUF permeate and RO permeate</li> </ul> </li> <li>- High COD received from TA-55 industrial line</li> <li>- Leak detected in WM-66 caustic tank</li> <li>- Continued to discharge only RO permeate</li> <li>- Contamination issues continued in WM-201 as a result of the leak in the caustic line from TA-55</li> </ul>

Table 2-1 Summary of TA-50 RLWTF Operations During CY 2003	
<b>October</b>	<ul style="list-style-type: none"> <li>- Normal operations included: IO, CL, SF, VF, TUF, IX, RO</li> <li>- Additional operations: <ul style="list-style-type: none"> <li>▪ MOX waste treatment continued</li> <li>▪ Retreatment of water due to high COD in influent</li> <li>▪ Trucked 40,000 gallons of high COD effluent to TA-53 solar basins</li> <li>▪ Evaporator campaign continued</li> </ul> </li> <li>- Pilot testing: ion exchange treatment of TUF permeate and RO permeate</li> <li>- Influent tanks were extremely full due to need to retreat water</li> <li>- Continued to discharge only RO permeate</li> <li>- High fluoride concentrations in the RLWTF influent</li> <li>- Contamination issues continued in WM-201 as a result of the leak in the caustic line from TA-55</li> <li>- Worked around leaking WM-66 caustic tank to keep TA-55 programs operational; initiated design of WM-66 caustic tank replacement</li> </ul>
<b>November</b>	<ul style="list-style-type: none"> <li>- Normal operations included: IO, CL, SF, VF, TUF, IX, RO</li> <li>- Additional operations: <ul style="list-style-type: none"> <li>▪ MOX waste treatment continued</li> <li>▪ Retreatment of water due to high COD in influent</li> <li>▪ Evaporator campaign completed</li> <li>▪ Installed new ion exchange columns</li> </ul> </li> <li>- Pilot testing: ion exchange treatment of TUF permeate and RO permeate</li> <li>- Continued to discharge only RO permeate</li> <li>- Contamination issues continued in WM-201 as a result of the leak in the caustic line from TA-55</li> <li>- Worked around leaking WM-66 caustic tank to keep TA-55 programs operational; continued design of WM-66 caustic tank replacement</li> </ul>
<b>December</b>	<ul style="list-style-type: none"> <li>- Normal operations included: IO, CL, SF, VF, TUF, IX, RO</li> <li>- Additional operations: <ul style="list-style-type: none"> <li>▪ MOX waste treatment continued</li> </ul> </li> <li>- High COD influent received from TA-55 (placed in 100K tank)</li> <li>- Continued to discharge only RO permeate</li> <li>- Contamination issues continued in WM-201 as a result of the leak in the caustic line from TA-55</li> <li>- Worked around leaking WM-66 caustic tank to keep TA-55 programs operational; continued design of WM-66 caustic tank replacement</li> </ul>

### 3. TA-50 RLWTF Influent and Effluent Flows in CY 2003

During CY 2003, the TA-50 RLWTF received 12,156,000 liters of influent radioactive liquid wastewater. Also, 11,257,000 liters of treated effluent were discharged from the facility via the National Pollutant Discharge Elimination System (NPDES) permitted outfall during CY 2003. Approximately 135,125 liters of evaporator bottoms were further evaporated to dryness and disposed of at the TA-54 radioactive solid waste facility. Appendix A is a tabular summary of the TA-50 RLWTF monthly flows. More detail on daily flows at the RLWTF is provided in Appendix B.

Table 3-1 gives effluent discharge information for the RLWTF during CY 2003. Discharges from the RLWTF via the NPDES permitted outfall occur in batches of approximately 73,000 liters. Each batch discharge, which lasts for approximately 45 minutes, travels via pipeline to Mortandad Canyon which lies just to the north of the TA-50 RLWTF. Batch discharges occur, on average, about three (3) times per week. Table 3-1 also indicates that ninety (90) percent of the water discharged in CY 2003 had received reverse osmosis treatment. The other ten (10) percent of the treated water discharged had met all regulatory discharge requirements with treatment up to and through tubular ultrafiltration and ion exchange. Beginning on April 8, 2003 all water discharged from the RLWTF received RO treatment in the effort to produce the highest quality effluent from the RLWTF.

Table 3-1 Effluent Discharge Information for the RLWTF During CY 2003

<b>Effluent Discharge Information for the RLWTF</b>			
JAN-2003 through DEC-2003			
Month	# of 051 Discharges	Volume of Discharges (liters)	Percent RO Permeate
Jan-03	16	1182460	64
Feb-03	11	813300	75
Mar-03	13	965000	65
Apr-03	14	1025100	91
May-03	13	958000	100
Jun-03	20	1472800	100
Jul-03	16	1218800	100
Aug-03	12	878354	100
Sep-03	12	888000	100
Oct-03	9	648200	100
Nov-03	10	725600	100
Dec-03	7	481700	100
<b>2003 Totals</b>	<b>153<sup>a</sup></b>	<b>11257314</b>	<b>90<sup>b</sup></b>
Issued 02/09/2004 14:55:52			

<sup>a</sup> Daily Operational Logs

<sup>b</sup> Flow weighted 2003 annual average

Table 3-2 tabularizes the TA-50 RLWTF influent and discharge flows on a monthly basis for CY 2003. Table 3-2 also shows that trucked transfers of water from the TA-21 RLWTF to the TA-50 RLWTF did not occur during CY 2003.

Table 3-2 TA-50 RLWTF Flow Summary During CY 2003

<b>TA-50 RLWTF</b>			
FLOW SUMMARY (megaliters)			
JAN-2003 through DEC-2003			
Date	Influent	TA-21 Transfer	Discharged
Jan-03	1.151	0	1.182
Feb-03	0.728	0	0.813
Mar-03	0.903	0	0.965
Apr-03	1.049	0	1.025
May-03	1.259	0	0.958
Jun-03	1.278	0	1.473
Jul-03	1.048	0	1.219
Aug-03	0.994	0	0.878
Sep-03	0.871	0	0.888
Oct-03	0.844	0	0.648
Nov-03	1.099	0	0.726
Dec-03	0.932	0	0.482
<b>Total</b>	<b>12.156</b>	<b>0</b>	<b>11.257</b>

Issued 01/14/2004 11:32:11

Effluent discharges from the TA-50 RLWTF have decreased over the years from 1967 to 2003 as demonstrated in Figure 3-1, which follows on the next page. The decreases in the 1980s were largely the result of programmatic issues; the decreases in the 1990s were largely the result of efforts to minimize the volume of radioactive liquid waste generation at LANL. Additionally, the removal of non-radioactive liquid wastes from the RLWCS has also reduced the volume of water in the RLWTF influent and, as a result, the effluent.

Figure 3-1 TA-50 Annual Discharge Volumes (1963 – 2003)

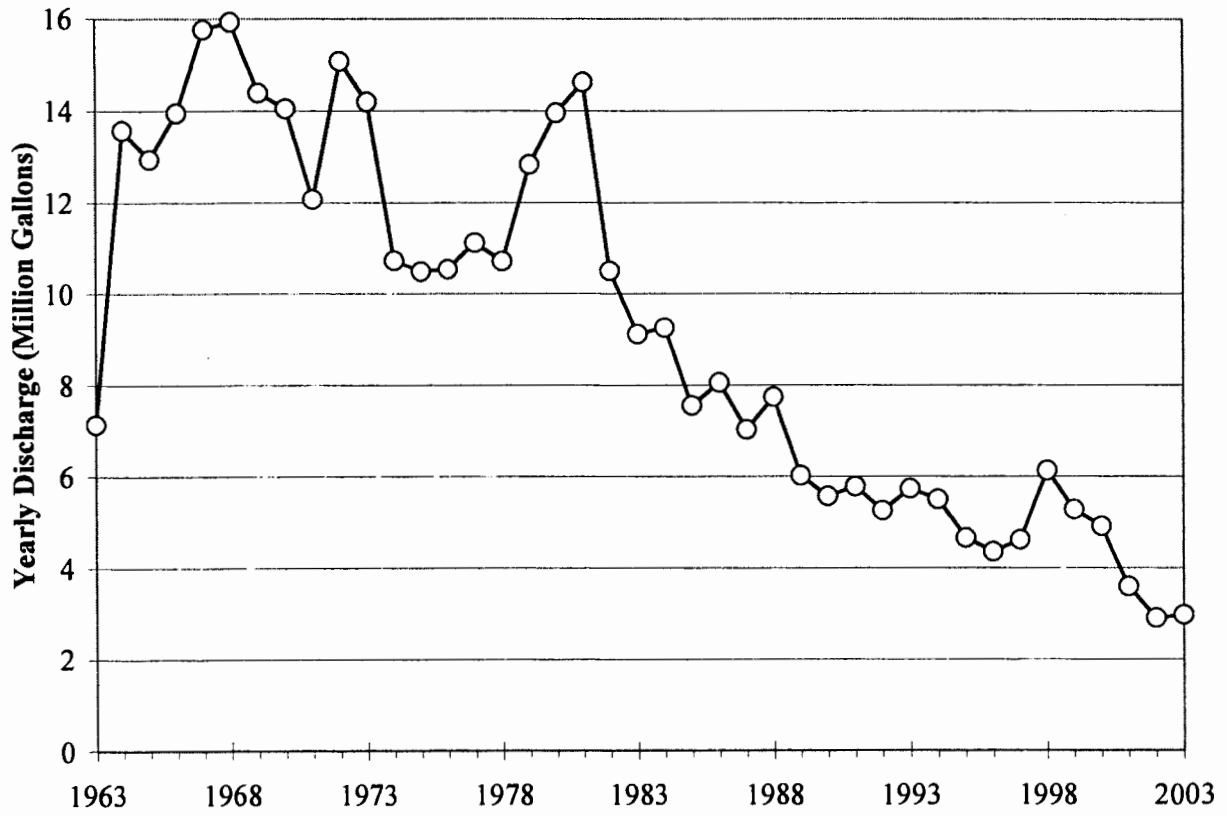



#### 4. Radiological Nature of the CY 2003 TA-50 RLWTF Influent and Effluent Waters and Process Waste Sludge

The influent wastewater to the TA-50 RLWTF is radioactive due to the presence of radionuclides that emit alpha and beta particles, gamma rays and neutrons. Table 4-1 shows the mass of the nine (9) major alpha particle emitting radionuclides in the RLWTF influent and also their mass in the effluent from the RLWTF in CY 2003. The table indicates that the treatment process at the RLWTF removes nearly 99.99% of the alpha emitters from the wastewater stream.

Table 4-1 Mass of Alpha Emitting Radionuclides in the RLWTF Influent and Effluent During CY 2003

Mass of Alpha Emitting Radionuclides in the RLWTF Influent and Effluent		
JAN-2003 through DEC-2003		
Mass in Influent (grams)	Alpha Particle Emitting Radionuclide	Mass in Effluent (grams)
223.2 E-3	Am-241	16.1 E-6
1.6 E0	Np-237	none detected
*	Ra-226	10.6 E-6
40.7 E-3	Pu-238	6.4 E-6
5.8 E0	Pu-239	690.4 E-6
25.4 E0	Th-232	838.7 E-3
1.4 E0	U-234	none detected
6.7 E0	U-235	none detected
1.3 E3	U-238	808.4 E-3

\* Less than Detection Limit  
 Issued 01/28/2004 11:17:39

There are thousands of naturally occurring and manmade radionuclides. Radiochemists analyze the RLWTF influent and effluent for thirty-eight (38) radionuclides which from past experience are probable in the LANL radioactive liquid waste. Sixteen (16) of these radionuclides were detected in the RLWTF influent and fourteen (14) were detected at very low activities in the RLWTF effluent in CY 2003. Table 4-2, shown on the next page, summarizes the radionuclides for which analyses are performed and also which radionuclides were detected in the RLWTF influent and effluent during CY 2003.

Table 4-3 on page 17 of this report presents the removal of gross alpha radiation from the RLWTF influent during CY 2003 on a month-by-month basis.

The next table, Table 4-4 which is shown on page 18, is the CY 2003 radionuclide summary for the TA-50 RLWTF. Appendix C displays the monthly radionuclide summaries. The information, in Table 4-4 and Appendix C, is a compilation of analytical information obtained from analyses performed on flow weighted monthly composite samples of both influent and effluent waters. Table 4-4 suggests that tritium removal occurs in the RLWTF treatment processes (raw influent is 11.1 nCi/L and final effluent is 7.2 nCi/L). This apparent removal is an analytical anomaly that is being corrected by the RLWTF radiochemists. In actuality, influent and effluent tritium concentrations are essentially the same.

Table 4-2 Radionuclide Analyses of the RLWTF Influent and Effluent in CY 2003

<b>Radionuclides Analyzed for in the RLWTF Influent and Effluent</b>	<b>Radionuclides Present in RLWTF Influent</b>	<b>Radionuclides Detected in RLWTF Effluent</b>
<i>Alpha Particle Emitters</i>		
Am-241	X	X
Np-237	X	
Ra-226		X
Pu-238	X	X
Pu-239	X	X
U-234	X	
U-235	X	
U-238	X	X
Th-232	X	X
<i>Beta Particle Emitters</i>		
As-74		X
Ba-133	X	
Be-7		X
Ce-141		X
Co-56, Co-57, Co-58 and Co-60		
Cs-134		
Cs-137	X	X
Eu-152		
H-3	X	X
I-133, Mn-52 and Mn-54		
Na-22	X	X
Ra-228		X
Rb-83		
Rb-84		
Sc-46, Sc-48 and Se-75		
Sn-113	X	
Sr-85	X	X
Sr-89		
Sr-90	X	
V-48		
Y-88	X	
Zn-65		
<b>38 Total</b>	<b>16 Total</b>	<b>14 Total</b>

Table 4-3 TA-50 RLWTF Gross Alpha Removal in CY 2003

TA-50 RLWTF Gross Alpha Removal			
JAN-2003 through DEC-2003			
Date	Raw (Ci)	Final (Ci)	Removal Factor 100X(INF - EFF)/INF
Jan-03	43.9 E-3	29. E-6	99.934
Feb-03	29.7 E-3	9.8 E-6	99.967
Mar-03	144.6 E-3	15.8 E-6	99.989
Apr-03	372.5 E-3	20.7 E-6	99.994
May-03	366.9 E-3	9.6 E-6	99.997
Jun-03	167.6 E-3	19.9 E-6	99.988
Jul-03	218.1 E-3	35. E-6	99.984
Aug-03	123.4 E-3	24.4 E-6	99.980
Sep-03	125.2 E-3	21.7 E-6	99.983
Oct-03	85.9 E-3	6.9 E-6	99.992
Nov-03	86.2 E-3	15.9 E-6	99.982
Dec-03	68.6 E-3	9.6 E-6	99.986

Issued 01/28/2004 11:44:22

Table 4-4 TA-50 RLWTF Radionuclide Summary in CY 2003

TA-50 RLWTF Radionuclide Summary										
JAN-2003 through DEC-2003										
	RAW Avg (nCi/L)	Maximum (nCi/L)	Minimum (nCi/L)	Number of Samples	Total (Ci)	FINAL Avg (pCi/L)	Maximum (pCi/L)	Minimum (pCi/L)	Number of Samples	Total (Ci)
ALPHA	142.1 E0	400. E0	35. E0	12	1.7 E0	10.5 E0	21. E0	4.7 E0	12	118. E-6
Am-241	63. E0	140. E0	17. E0	12	765.3 E-3	4.9 E0	10. E0	980. E-3	12	55.1 E-6
As-74	0	*	*	12	0	70.9 E0	360. E0	22. E0	12	798.6 E-6
BETA	6.4 E0	26. E0	3.3 E0	12	78.3 E-3	97.5 E0	420. E0	26. E0	12	1.1 E-3
Ba-133	46.3 E-3	670. E-3	83. E-3	2	562.5 E-6					0
Be-7	0	*	*	12	0	34.9 E0	410. E0	410. E0	12	392.8 E-6
Ce-141	0	*	*	12	0	14.5 E0	170. E0	170. E0	12	162.9 E-6
Co-56	0	*	*	12	0	0	*	*	12	0
Co-57	0	*	*	12	0	0	*	*	12	0
Co-58	0	*	*	12	0	0	*	*	12	0
Co-60	0	*	*	12	0	0	*	*	12	0
Cs-134	0	*	*	12	0	0	*	*	12	0
Cs-137	45.5 E-3	380. E-3	4.1 E-3	12	553.3 E-6	54.6 E0	290. E0	9.1 E0	12	614.3 E-6
Eu-152	0	*	*	12	0	0	*	*	12	0
I-133	0	*	*	12	0	0	*	*	12	0
Mn-52	0	*	*	12	0	0	*	*	12	0
Mn-54	0	*	*	12	0	0	*	*	12	0
Na-22	2.9 E-3	49. E-3	49. E-3	12	35.7 E-6	1.6 E0	14. E0	5.8 E0	12	18.2 E-6
Np-237	93.2 E-3	900. E-3	900. E-3	12	1.1 E-3	0	*	*	12	0
Pu-238	57.4 E0	160. E0	13. E0	12	697.8 E-3	9.7 E0	18. E0	3.5 E0	12	109.4 E-6
Pu-239	29.5 E0	59. E0	7.7 E0	12	359.1 E-3	3.8 E0	7.7 E0	1.7 E0	12	42.9 E-6
Ra-226	0	*	*	12	0	934.8 E-3	8.9 E0	8.9 E0	12	10.5 E-6
Ra-228	0	*	*	12	0	847.4 E-3	5.5 E0	5.3 E0	12	9.5 E-6
Rb-83	0	*	*	12	0	0	*	*	12	0
Rb-84	0	*	*	12	0	0	*	*	12	0
Sc-46	0	*	*	12	0	0	*	*	12	0
Sc-48	0	*	*	12	0	0	*	*	12	0
Se-75	0	*	*	12	0	0	*	*	12	0
Sn-113	1.4 E-3	19. E-3	19. E-3	12	17.2 E-6	0	*	*	12	0
Sr-85	27.3 E-3	250. E-3	42. E-3	12	331.7 E-6	3.4 E0	40. E0	40. E0	12	38.3 E-6
Sr-89	0	*	*	12	0	0	*	*	12	0
Sr-90	15.5 E-3	120. E-3	110. E-3	12	188.4 E-6	0	*	*	12	0
TRITIUM	0	*	*	0	0	10.4 E3	17. E3	3.6 E3	12	117.1 E-3
Th-232	230.2 E-6	580. E-6	40. E-6	12	2.8 E-6	8.2 E-3	50. E-3	30. E-3	12	92.3 E-9
U-234	705.5 E-3	5.7 E0	28. E-3	12	8.6 E-3	0	*	*	12	0
U-235	1.2 E-3	2.1 E-3	500. E-6	12	14.5 E-6	0	*	*	12	0
U-238	36.9 E-3	56.4 E-3	18.6 E-3	12	448.3 E-6	24.1 E-3	140. E-3	110. E-3	12	271.7 E-9
V-48	0	*	*	12	0	0	*	*	12	0
Y-88	1.2 E-3	16. E-3	16. E-3	12	14.4 E-6	0	*	*	12	0
Zn-65	0	*	*	12	0	0	*	*	12	0

Volume of Flow: Influent = 12156083 liters Final = 11257314 liters

\* Less than Detection Limit

Issued 01/27/2004 13:56:35

In 1990 DOE issued Order 5400.5, Radiation Protection of the Public and the Environment, which established revised guidelines for the effluent waters from DOE facilities. The Order identified Derived Concentration Guidelines (DCGs) for all radionuclides discharged from DOE facilities. The concentration of each radionuclide divided by its particular DCG value results in a ratio. For waters containing more than one radionuclide, a ratio will be found for each radionuclide. For a water to be in compliance with Order 5400.5, the sum of the ratios cannot exceed 1.0. The radionuclides of primary concern in the RLWTF effluent are Pu-238, Pu-239, and Am-241. These three isotopes typically account for greater than 90% of the sum of the ratios in the RLWTF effluent.

Compliance with this Order insures that the yearly dose will be less than 100 millirem to a person drinking 2 liters of this water per day. The *millirem* is a unit for measuring the biological effects of radiation on the human body. The average annual radiation dose equivalent to a member of the general population of the United States from both natural and manmade sources is about 361 millirem (mrem). Of this average total radiation dose, 296 mrem is from naturally occurring radiation sources and the remaining 65 mrem is from manmade radiation sources. Figure 4-1 demonstrates that for CY 2003 the RLWTF effluent was in compliance with DOE Order 5400.5.

Figure 4-1 Twelve Month Flow Weighted Sum of Ratios of the TA-50 RLWTF Effluent During CY 2003 (DOE Order 5400.5)

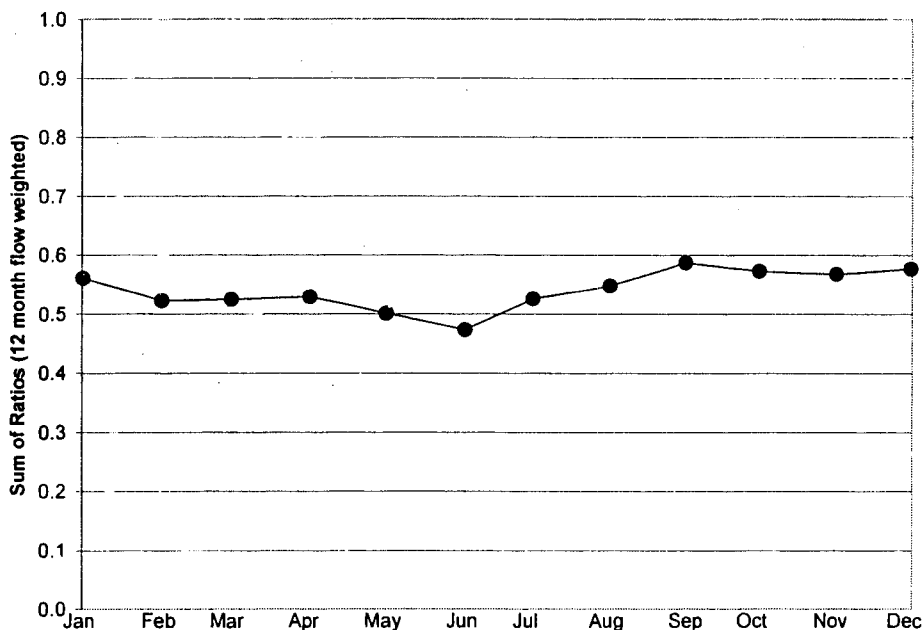

The flow weighted sum of ratios for CY 2003 is 0.577 as shown in Table 4-5 on the following page.

Table 4-5 TA-50 RLWTF Effluent Compared with DOE Order 5400.5 in CY 2003

TA-50 RLWTF Effluent Compared with DCG 5400.5			
JAN-2003 through DEC-2003			
Radioactive Isotopes	Mean Concentration (picoCi/L)	DCG 5400.5 (picoCi/L)	Conc/DCG Ratio
Am-241	4.9 E0	30	163.2 E-3
As-74	70.9 E0	40000	1.8 E-3
Ba-133		40000	
Be-7	34.9 E0	1000000	34.9 E-6
Ce-141	14.5 E0	50000	289.3 E-6
Co-56		10000	
Co-57		100000	
Co-58		40000	
Co-60		5000	
Cs-134		2000	
Cs-137	54.6 E0	3000	18.2 E-3
Eu-152		20000	
I-133		10000	
Mn-52		20000	
Mn-54		50000	
Na-22	1.6 E0	10000	161.9 E-6
Np-237		30	
Pu-238	9.7 E0	40	243.1 E-3
Pu-239	3.8 E0	30	126.9 E-3
Ra-226	934.8 E-3	100	9.3 E-3
Ra-228	847.4 E-3	100	8.5 E-3
Rb-83		20000	
Rb-84		10000	
Sc-46		20000	
Sc-48		20000	
Se-75		20000	
Sn-113		50000	
Sr-85	3.4 E0	70000	48.6 E-6
Sr-89		20000	
Sr-90		1000	
TRITIUM	10.4 E3	2000000	5.2 E-3
Th-232	8.2 E-3	50	164. E-6
U-234		500	
U-235		600	
U-238	24.1 E-3	600	40.2 E-6
V-48		30000	
Y-88		30000	
Zn-65		9000	
Sum of Ratios = 0.577			
Issued 01/28/2004 12:05:40			

The following series of seven (7) figures highlight significant information which pertains to the radiological nature of the TA-50 RLWTF influent and effluent.

The upper graph in Figure 4-2 shows the gross alpha activity in the raw daily influent water to the RLWTF and the gross alpha activity in the effluent from the RLWTF in monthly composite samples during CY 2003. The lower graph in Figure 4.2 shows more detail on the gross alpha activity in the CY 2003 effluent by changing the scale to picocuries per liter.

The upper graph in Figure 4-3 shows the Pu-238 activity in the raw daily influent water to the RLWTF and the Pu-238 activity in the effluent from the RLWTF in monthly composite samples during CY 2003. The lower graph in Figure 4.3 shows more detail on the Pu-238 activity in the CY 2003 effluent by changing the scale to picocuries per liter.

The upper graph in Figure 4-4 shows the Pu-239 activity in the raw daily influent water to the RLWTF and the Pu-239 activity in the effluent from the RLWTF in monthly composite samples during CY 2003. The lower graph in Figure 4.4 shows more detail on the Pu-239 activity in the CY 2003 effluent by changing the scale to picocuries per liter.

The upper graph in Figure 4-5 shows the Am-241 activity in the raw daily influent water to the RLWTF and the Am-241 activity in the effluent from the RLWTF in monthly composite samples during CY 2003. The lower graph in Figure 4.5 shows more detail on the Am-241 activity in the CY 2003 effluent by changing the scale to picocuries per liter.

The upper graph in Figure 4-6 shows the gross beta activity in the raw daily influent water to the RLWTF and the gross beta activity in the effluent from the RLWTF in monthly composite samples during CY 2003. The lower graph in Figure 4.6 shows more detail on the gross beta activity in the CY 2003 effluent by changing the scale to picocuries per liter.

The upper graph in Figure 4-7 shows the Sr-90 activity in the raw daily influent water to the RLWTF and the Sr-90 activity in the effluent from the RLWTF in monthly composite samples during CY 2003. The lower graph in Figure 4.7 shows more detail on the Sr-90 activity in the CY 2003 effluent by changing the scale to picocuries per liter.

The upper graph in Figure 4-8 shows the tritium (H-3) activity in the raw daily influent water to the RLWTF and the Tritium (H-3) activity in the effluent from the RLWTF in monthly composite samples during CY 2003. The lower graph in Figure 4-8 shows the Sr-89 activity in the raw daily influent water to the RLWTF and the Sr-89 activity in the effluent from the RLWTF in monthly composite samples during CY 2003.

As shown in Table 4-6, a total of 161 drums (24,973 kilograms) of vacuum filter sludge were shipped to the TA-54 radioactive solid waste disposal facility at LANL during CY 2003. Shipments of drums were made in February, March, April, July, August, and October of 2003. Curies of U-235, Pu-238, Pu-239 and Am-241 associated with the sludge drums is also provided in Table 4-6.

Figure 4-2 Gross Alpha Activity in the RLWTF Influent and Effluent During CY 2003

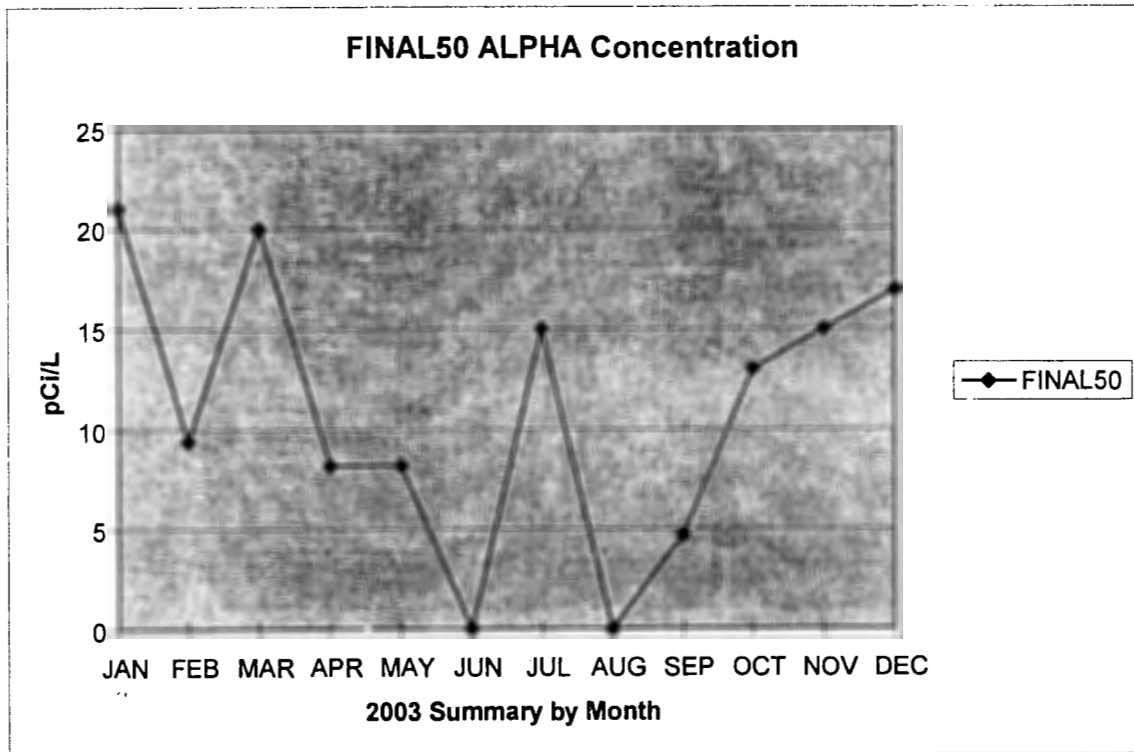
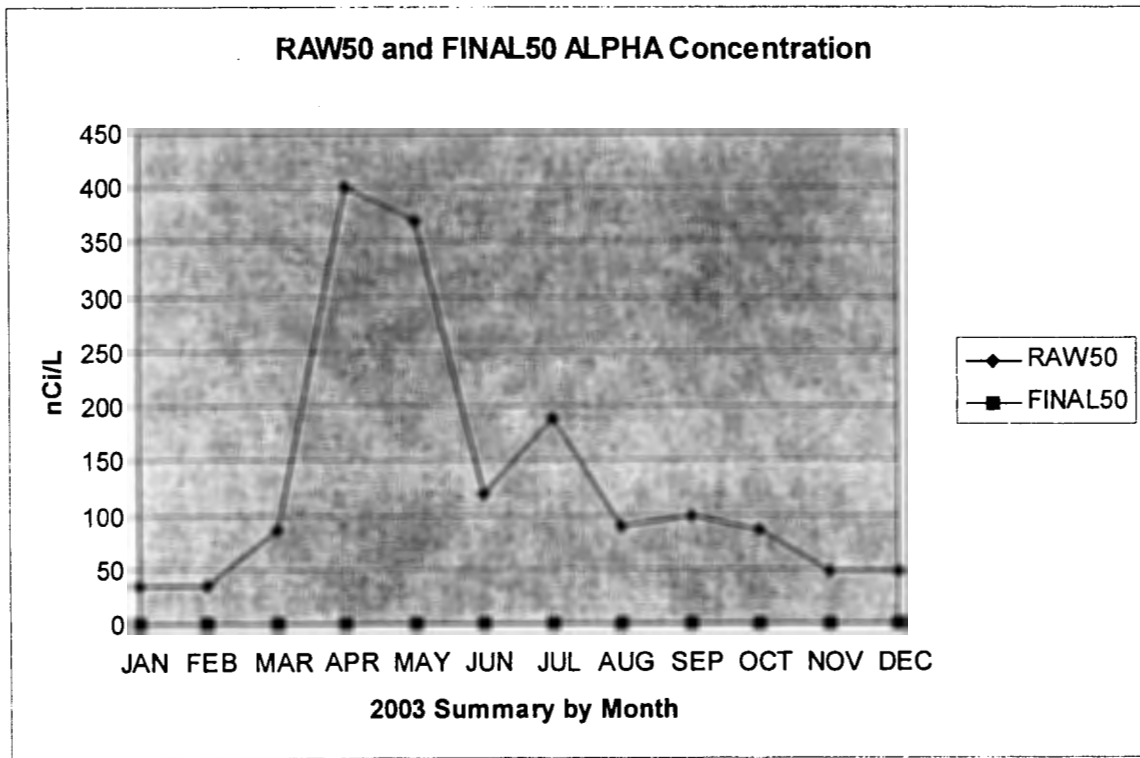
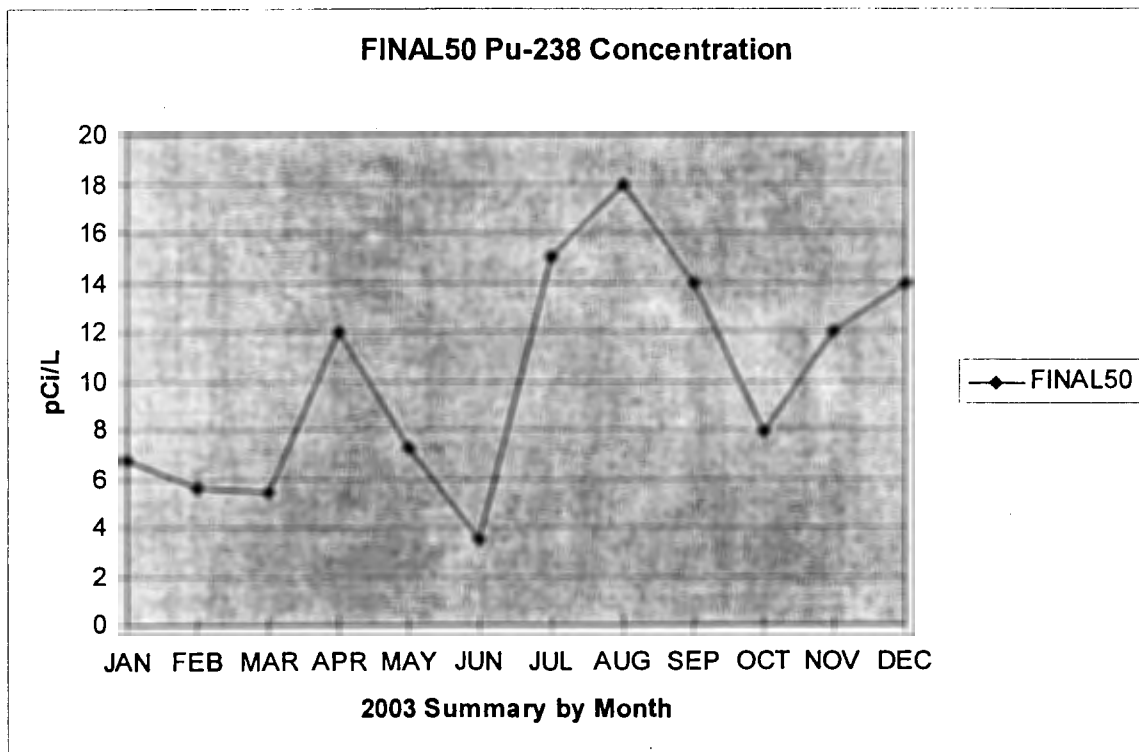
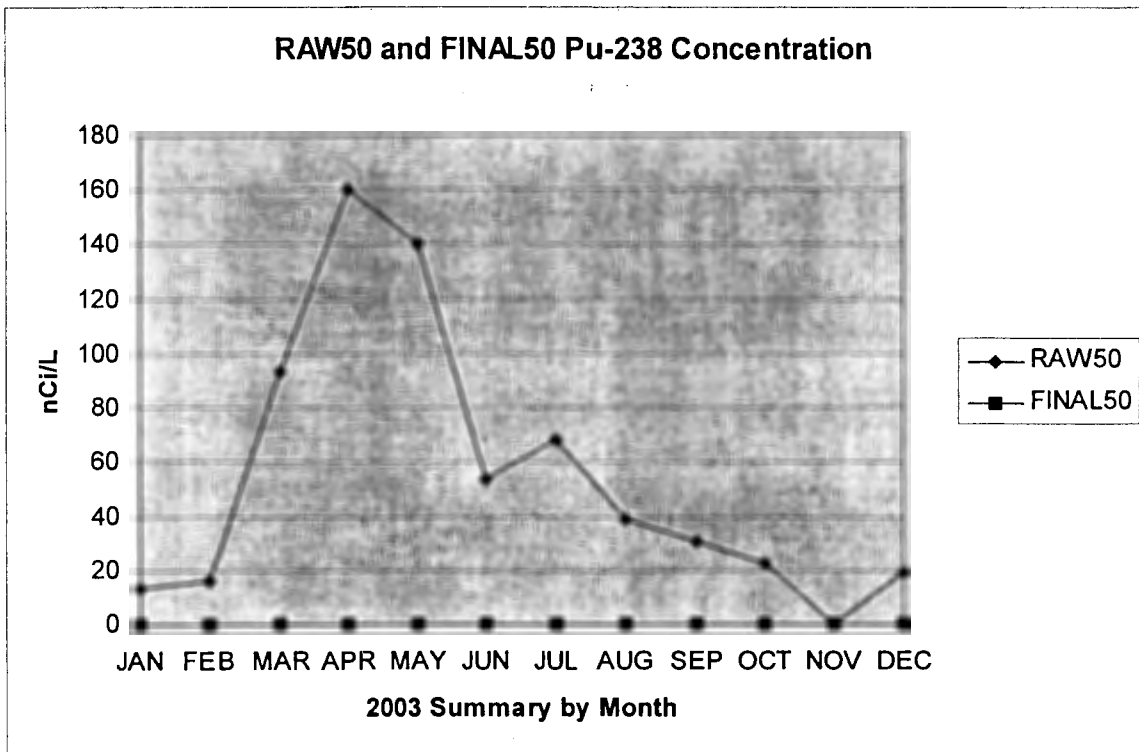

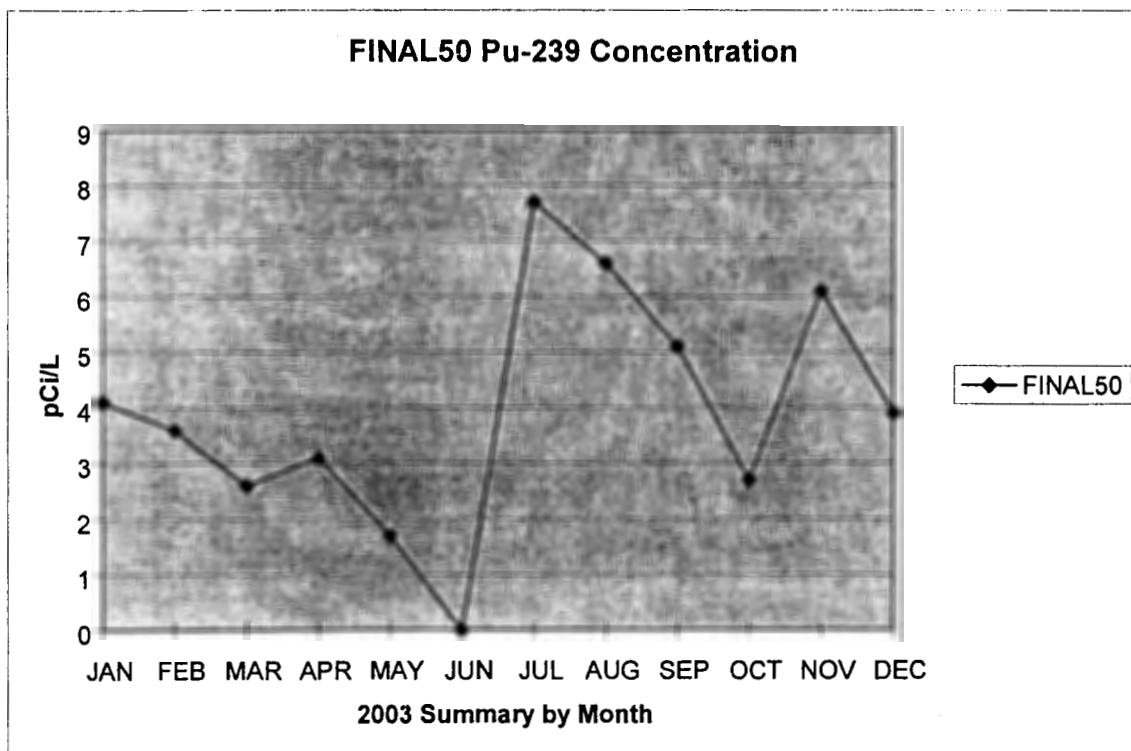
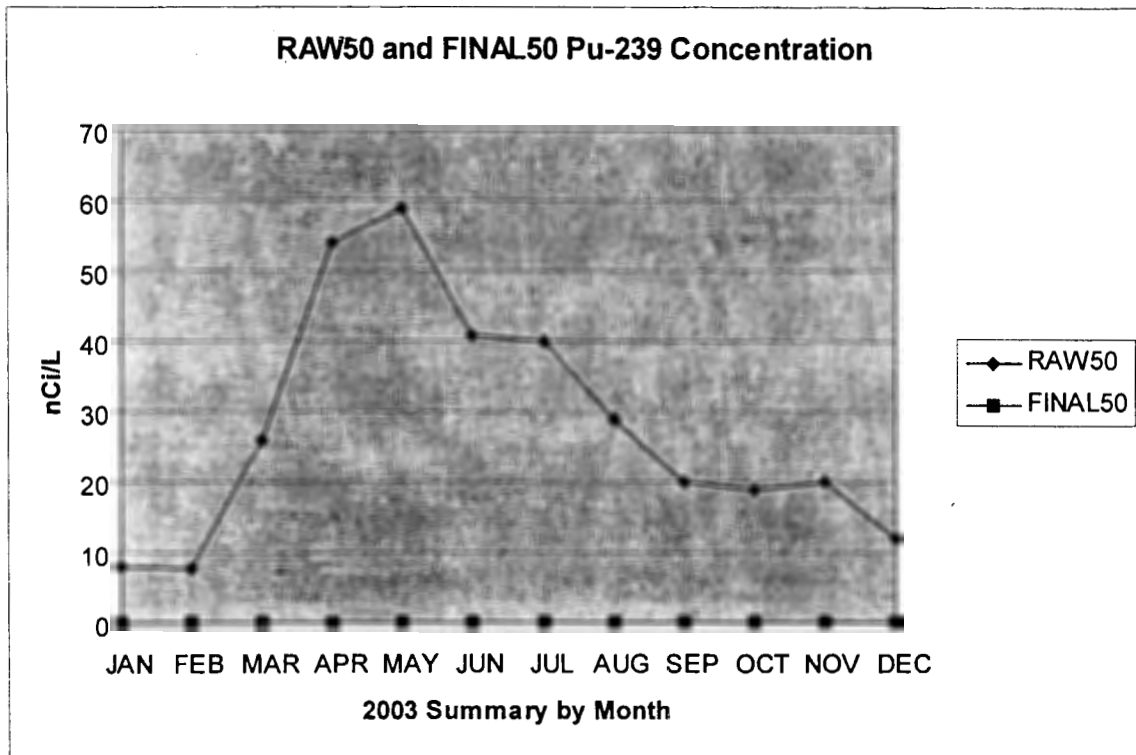

Figure 4-3 Pu-238 Activity in the RLWTF Influent and Effluent During CY 2003



DCG limit = 40 pCi/L

Figure 4-4 Pu-239 Activity in the RLWTF Influent and Effluent During CY 2003



DCG limit = 30 pCi/L

Figure 4-5 Am-241 Activity in the RLWTF Influent and Effluent During CY 2003

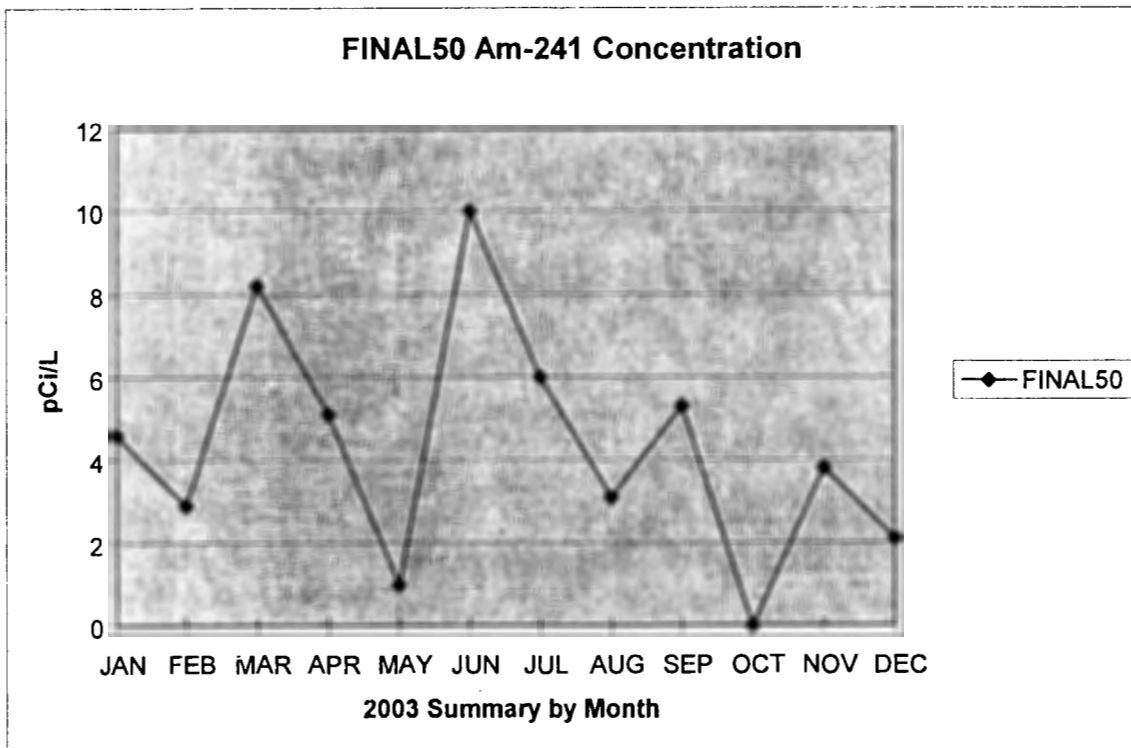
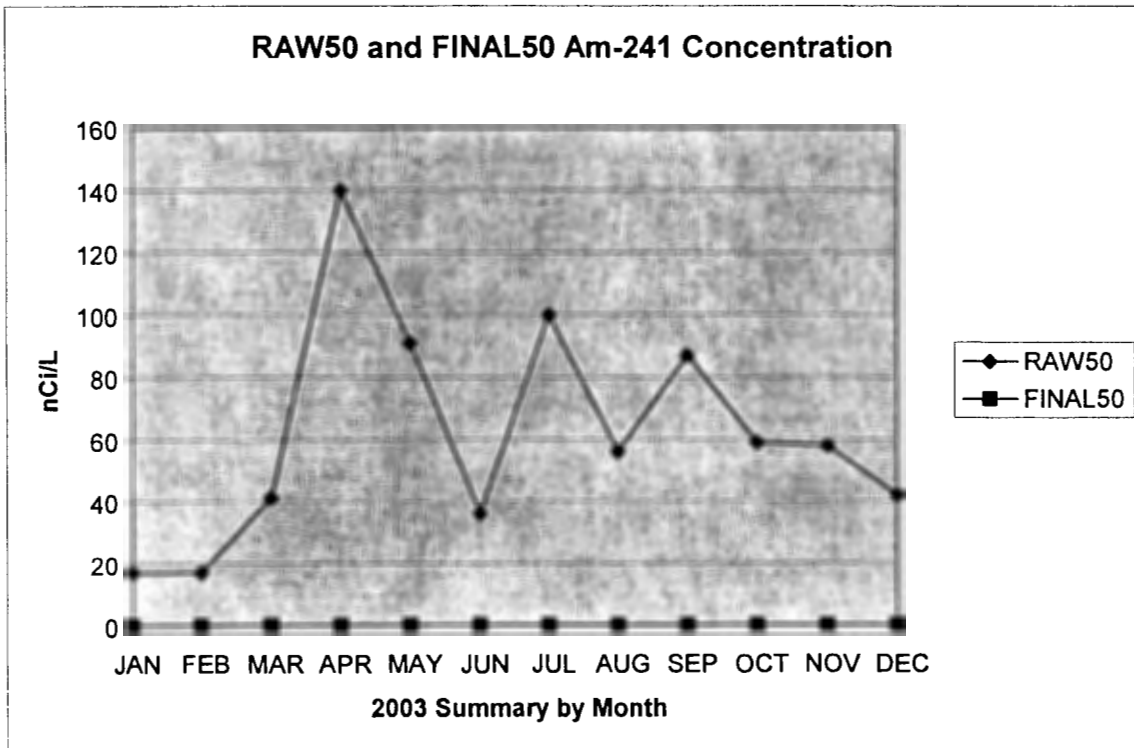

DCG limit = 30 pCi/L

Figure 4-6 Gross Beta Activity in the RLWTF Influent and Effluent During CY 2003

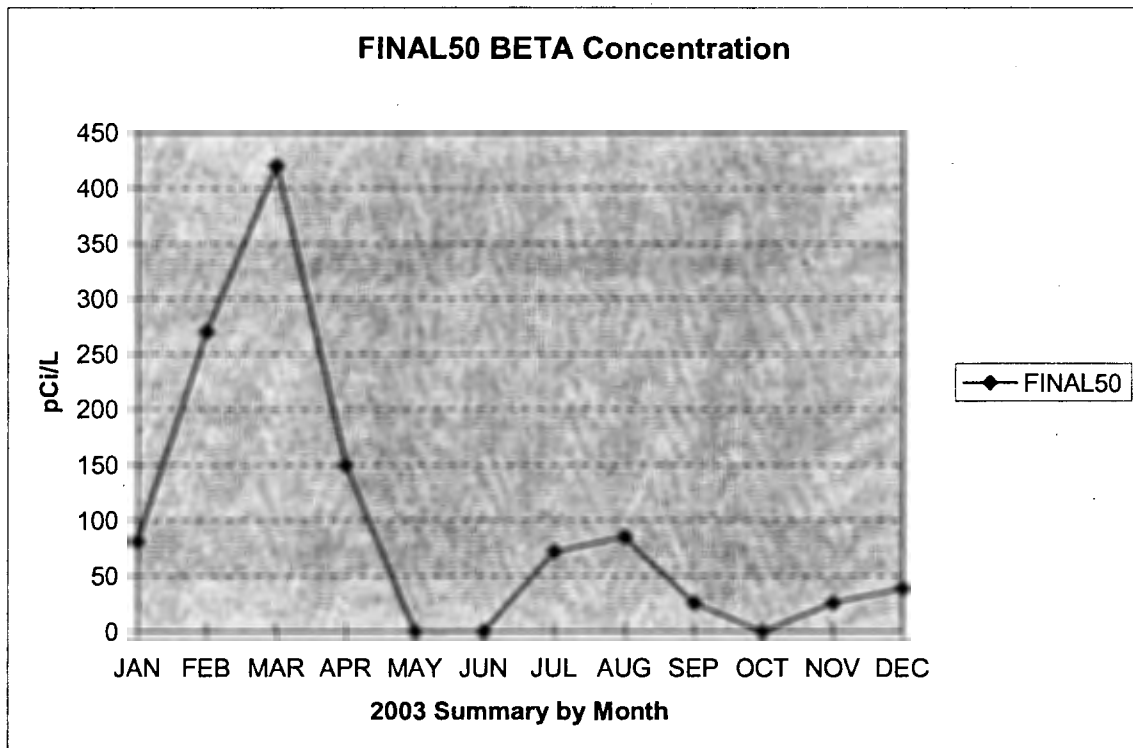
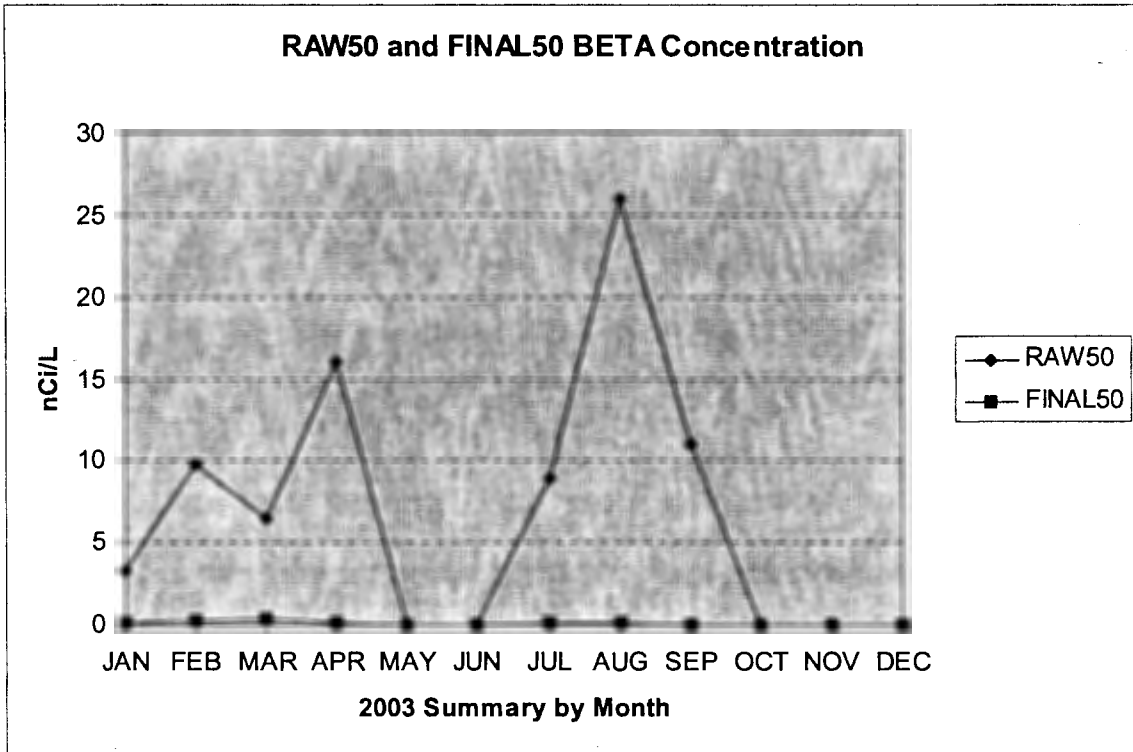
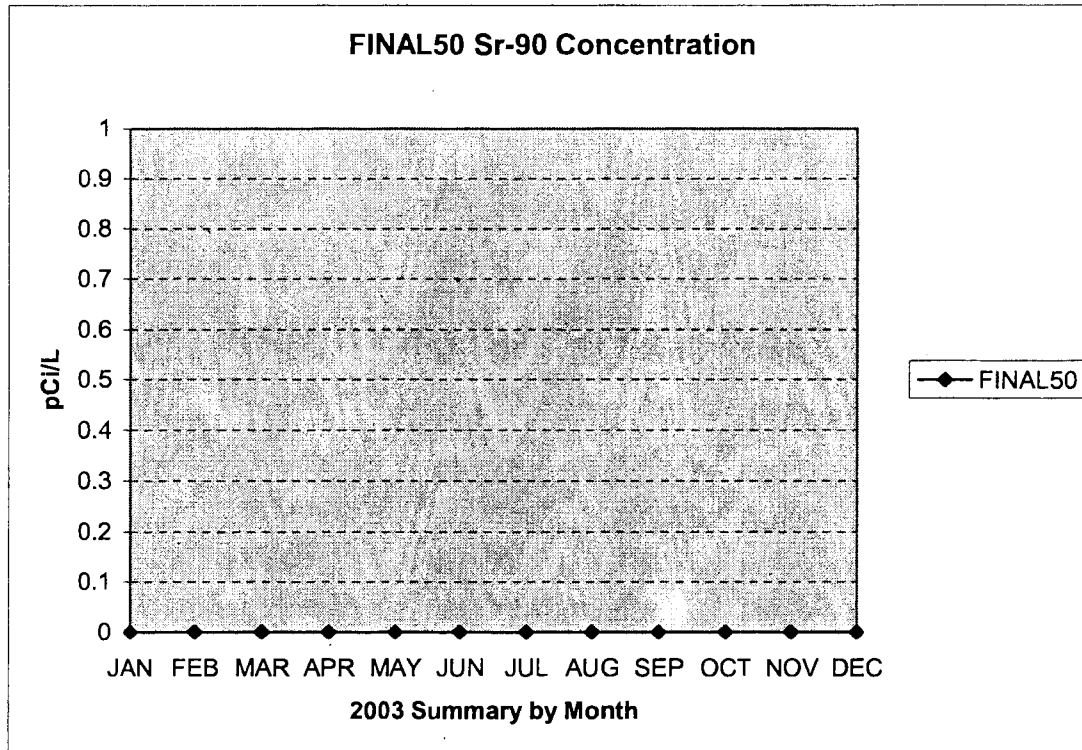
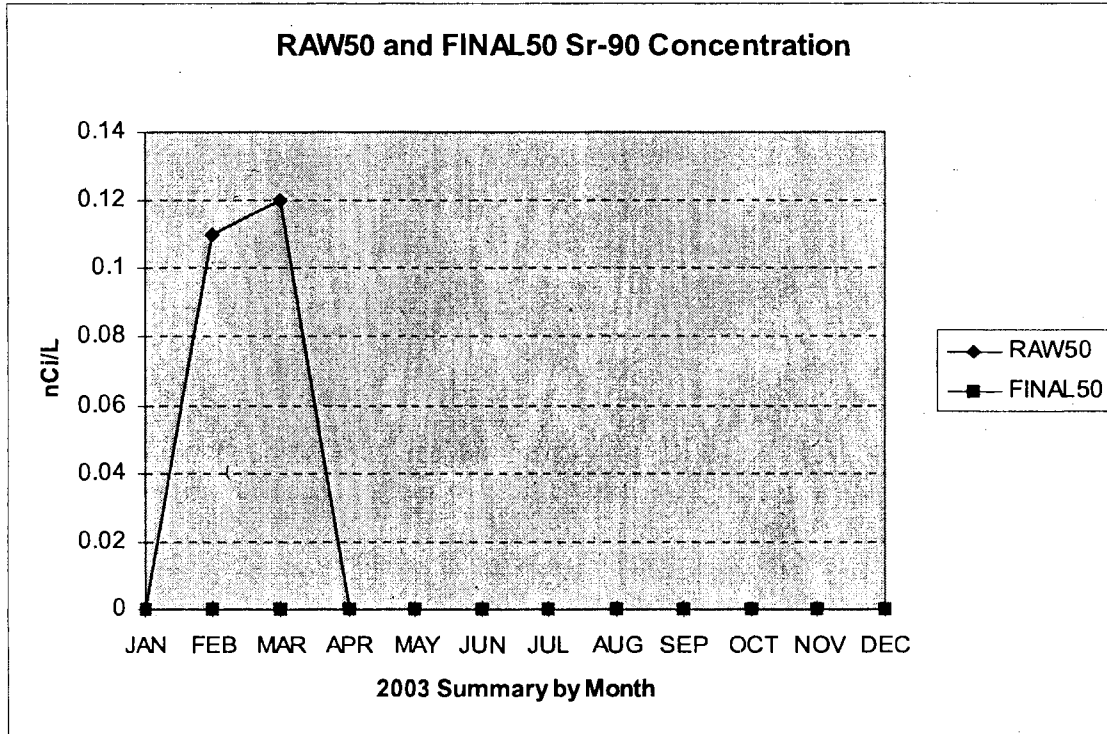

Figure 4-7 Sr-90 Activity in the RLWTF Influent and Effluent During CY 2003



DCG limit = 1000 pCi/L

Figure 4-8 H-3 and Sr-89 Activity in the RLWTF Influent and Effluent During CY 2003

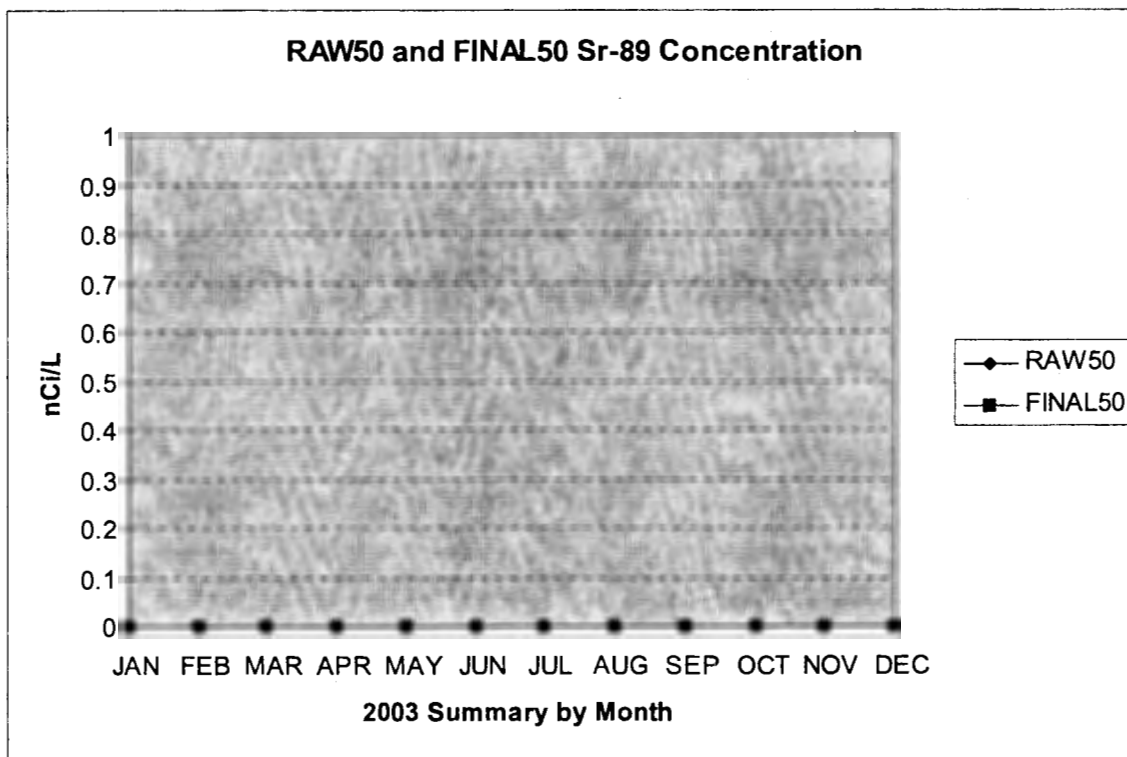
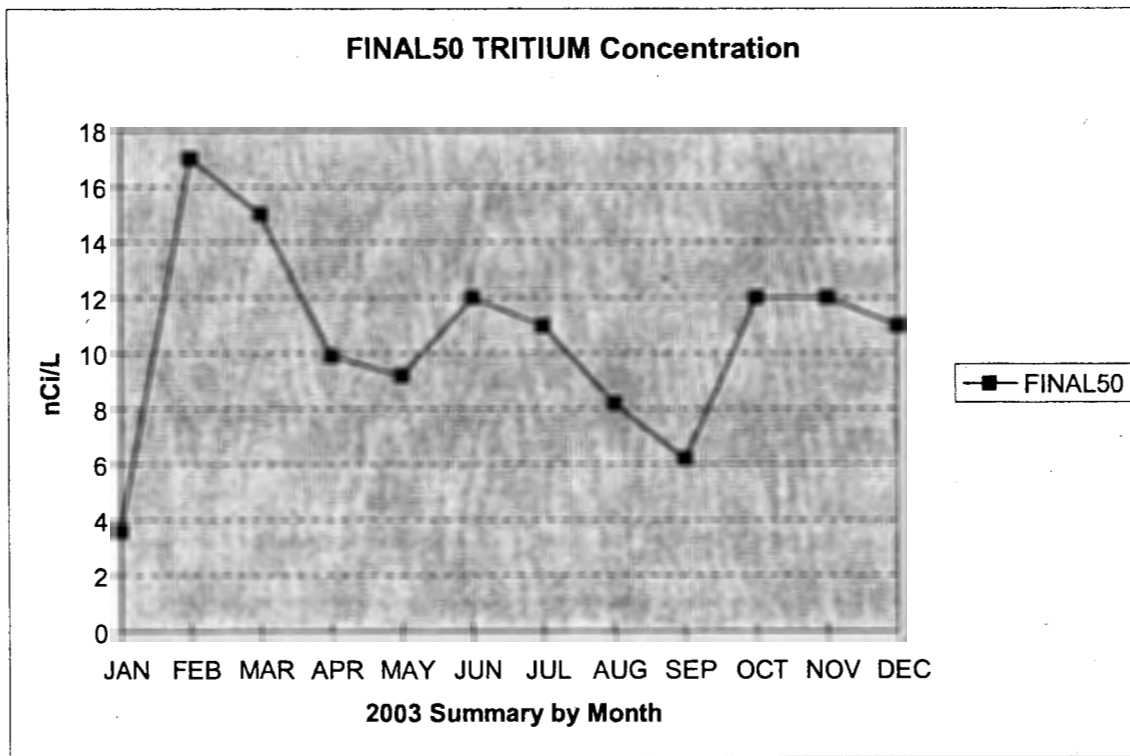

Table 4-6 TA-50 RLWTF Vacuum Filter Sludge Drums Shipped During CY 2003

<b>TA-50 RLWTF</b>									
TA-50-1-116, Vacuum Filter Drums Shipped for Disposal									
JAN-2003 through DEC-2003									
Month	No. of Drums	Total Volume (Liters)	Gross Weight (Kg)	U-234 (Curies)	U-235 (Curies)	Pu-238 (Curies)	Pu-239 (Curies)	Am-241 (Curies)	
Jan-03	0	0	0	0	0	0	0	0	0
Feb-03	20	4160	3000.45	0	5.59E-07 +/- 2.08E-07	1.58E-02 +/- 7.02E-03	2.51E-03 +/- 3.94E-04	1.07E-02 +/- 1.43E-03	
Mar-03	22	4576	3402.77	0	6.39E-07 +/- 2.38E-07	1.80E-02 +/- 8.03E-03	2.87E-03 +/- 4.51E-04	1.23E-02 +/- 1.64E-03	
Apr-03	9	1872	1367.68	8.19E-05 +/- 9.83E-06	4.26E-07 +/- 3.28E-08	4.59E-03 +/- 3.28E-04	1.28E-03 +/- 1.31E-04	4.26E-03 +/- 3.28E-04	
May-03	0	0	0	0	0	0	0	0	0
Jun-03	0	0	0	0	0	0	0	0	0
Jul-03	27	5616	4056.72	1.16E-05 +/- 9.71E-07	5.73E-07 +/- 1.35E-07	1.71E-02 +/- 4.76E-03	3.94E-03 +/- 4.42E-04	1.33E-02 +/- 1.33E-03	
Aug-03	37	7696	5816.23	4.56E-05 +/- 4.64E-06	9.88E-07 +/- 8.99E-08	1.80E-02 +/- 1.50E-03	6.15E-03 +/- 6.00E-04	1.95E-02 +/- 1.50E-03	
Sep-03	0	0	0	0	0	0	0	0	0
Oct-03	23	4784	3788.78	4.53E-05 +/- 4.49E-06	3.92E-07 +/- 4.13E-08	2.22E-02 +/- 2.06E-03	9.29E-03 +/- 1.24E-03	1.91E-02 +/- 2.95E-03	
Nov-03	0	0	0	0	0	0	0	0	0
Dec-03	0	0	0	0	0	0	0	0	0
<b>TOTAL</b>	<b>138</b>	<b>28704</b>	<b>21432.63</b>	<b>1.84E-04 +/- 1.99E-05</b>	<b>3.58E-06 +/- 7.45E-07</b>	<b>9.56E-02 +/- 2.37E-02</b>	<b>2.60E-02 +/- 3.26E-03</b>	<b>7.91E-02 +/- 9.18E-03</b>	

Issued 01/14/2004 11:45:21

**5. Non-Radiological Nature of the CY 2003 TA-50 RLWTF Influent and Effluent Waters and Process Waste Sludge**

In addition to radionuclides, the influent wastewater to the TA-50 RLWTF also includes many other inorganic and organic contaminants that require treatment prior to discharge via the NPDES permitted outfall to the environment. Twenty-one (21) parameters in the effluent from the RLWTF are regulated by the National Pollutant Discharge Elimination System (NPDES) in compliance with the Federal Clean Water Act. LANL also has a voluntary commitment with the New Mexico Environment Department (NMED) to not discharge effluent from the TA-50 RLWTF that exceeds groundwater standards set by the New Mexico Water Quality Control Commission (NMWQCC) for three (3) water quality parameters: fluoride, nitrate-nitrogen and total dissolved solids (TDS). Table 5-1 identifies these 24 discharge parameters and also indicates the frequency of sampling required for each parameter.

Table 5-1 NPDES and NMED Discharge Parameters

NPDES (21 parameters)			NMED (3 parameters)
pH <sup>1</sup>	Copper <sup>1</sup>	Selenium <sup>3</sup>	Fluoride <sup>5</sup>
Aluminum <sup>3</sup>	Iron <sup>1</sup>	Zinc <sup>1</sup>	Nitrate Nitrogen <sup>5</sup>
Arsenic <sup>3</sup>	Lead <sup>1</sup>	Chemical Oxygen Demand <sup>1</sup>	Total Dissolved Solids <sup>5</sup>
Boron <sup>3</sup>	Mercury <sup>1</sup>	Total Suspended Solids <sup>1</sup>	
Cadmium <sup>1</sup>	Nickel <sup>2</sup>	Total Toxic Organics <sup>2</sup>	
Chromium <sup>1</sup>	Perchlorate <sup>3</sup>	Tritium (accelerator produced) <sup>3</sup>	
Cobalt <sup>3</sup>	Radium-226 + Radium-228 <sup>3</sup>	Flow <sup>4</sup>	

<sup>1</sup> weekly grab sample

<sup>2</sup> monthly grab sample

<sup>3</sup> yearly grab sample

<sup>4</sup> continuous record

<sup>5</sup> each discharge

The quantitative limits for the twenty-four (24) NPDES and three (3) NMED discharge parameters which pertain to the RLWTF effluent are given in Table 5-2.

The TA-50 RLWTF effluent, for the 4<sup>th</sup> consecutive year, was in compliance with all twenty-one (21) NPDES water quality parameters during calendar year 2003.

LANL also has a voluntary commitment with the New Mexico Environment Department (NMED) to not discharge effluent from the TA-50 RLWTF that exceeds groundwater standards set by the New Mexico Water Quality Control Commission (NMWQCC) for three (3) water quality parameters: fluoride, nitrate-nitrogen and total dissolved solids (TDS). Two (2) weekly composite samples of RLWTF effluent slightly exceeded the



NMED groundwater standard for fluoride of 1.6 mg/L (sample values were 2.07 mg/L and 1.64 mg/L). Each effluent tank is now analyzed for fluoride prior to discharge to ensure that the voluntary commitment is not exceeded again.

Table 5-2 Discharge Limits for NPDES and NMED Parameters in the RLWTF Effluent

NPDES Parameters	Monthly Average (mg/L)	Daily Max (mg/L)
Flow	Report	Report
pH	6 – 9 su	6 – 9 su
Chemical Oxygen Demand	125	125
Total Suspended Solids	30	45
Total Cadmium	0.05	0.05
Total Chromium	1.34	2.68
Total Copper	1.393	1.393
Total Iron	-----	-----
Total Lead	0.423	0.524
Total Mercury	0.00077	0.00077
Total Zinc	4.37	8.75
Total Toxic Organics	1.0	1.0
Total Arsenic	0.368	0.368
Total Aluminum	5.0	5.0
Total Boron	5.0	5.0
Total Cobalt	1.0	1.0
Total Selenium	0.005	0.005
Total Vanadium	0.1	0.1
Radium 226 + Radium 228	30 pCi/L	30 pCi/L
Tritium (when accelerator produced)	20,000 pCi/L	20,000 pCi/L
Total Nickel	Report	Report
Perchlorate	Report	Report
<b>NMED Parameters</b>	<b>Per Discharge (mg/L)</b>	
Fluoride	1.6	
Nitrate-nitrogen	10.0	
Total Dissolved Solids	1,000	

Table 5-3 shows the flow-weighted concentrations for CY 2003 of the TA-50 RLWTF effluent in comparison to the NPDES and NMED standards. The table indicates that the RLWTF effluent is well below the discharge standards on all parameters. It is noted in Table 5-3 that the cadmium concentration in the final effluent during CY 2003 was less than the detection limit (LDL) of the analytical procedure. The LDL for cadmium is 0.003 mg/L. Also, the selenium concentration in the final effluent during CY 2003 was below the LDL of 0.001 mg/L.

The next table, Table 5-4, is the CY 2003 mineral summary for the TA-50 RLWTF. This information is a compilation of analytical information obtained from analyses performed on flow weighted monthly composite samples of both influent and effluent waters. Appendix D is the TA-50 RLWTF monthly mineral summaries during CY 2003.

Table 5-3 TA-50 RLWTF Effluent Compared to NPDES and NMED Standards During CY 2003

TA-50 RLWTF Effluent Compared to NPDES and NMED Standards			
JAN-2003 through DEC-2003			
Regulator	Regulated Parameter	Standard (mg/L)	FINAL Avg. (mg/L)
NPDES	ALUMINUM	5. E0	34.3 E-3
NPDES	ARSENIC	368. E-3	3.7 E-3
NPDES	BORON	5. E0	61.6 E-3
NPDES	CADMIUM	50. E-3	234.1 E-6
NPDES	COBALT	1. E0	273.1 E-6
NPDES	COD	125. E0	32.9 E0
NPDES	COPPER	1.4 E0	19.3 E-3
NMED	FLUORIDE	1.6 E0	384.5 E-3
NPDES	LEAD	423. E-3	< 20. E-3
NPDES	MERCURY	770. E-6	39.1 E-6
NMED	NITRATE-N	10. E0	626.8 E-3
NPDES	RADIUM*	30. E-12*	
NPDES	SELENIUM	5. E-3	< 1. E-3
NMED	TDS	1. E3	130.5 E0
NPDES	TOTAL CHROMIUM	1.3 E0	78. E-6
NPDES	TOXIC ORGANICS**	1	474. E0**
NPDES	TSS	30. E0	< 4. E0
NPDES	VANADIUM	100. E-3	12.9 E-3
NPDES	ZINC	4.4 E0	7.5 E-3
NPDES	pH	9. E0	7.4 E0
NPDES	IRON	Report Only	62.9 E-3
NPDES	NICKEL	Report Only	< 1. E-2
NPDES	PERCHLORATE	Report Only	< 2. E-3

FINAL Avg. = Flow-weighted average concentration in effluent.

\*Values for radioactive species reported as picocuries/Liter.

\*\*Value for toxic organics reported as micrograms/Liter.

Issued 01/22/2004 12:56:11

Table 5-4 TA-50 RLWTF Mineral Summary for CY 2003

TA-50 RLWTF Mineral Summary										
JAN-2003 through DEC-2003										
	RAW			No. Samp.	Total (Kg)	FINAL			No. Samp.	Total (Kg)
	Average	Maximum	Minimum			Average	Maximum	Minimum		
ALKALINITY-MO**	97.6 E0	212. E0	34.7 E0	12	1.2 E3	126.7 E0	284. E0	42.2 E0	12	1.4 E3
ALKALINITY-P**	3.4 E0	26.4 E0	7.2 E0	12	41.5 E0	0	*	*	12	0
ALUMINIUM	1. E0	3.5 E0	259. E-3	12	12.4 E0	34.3 E-3	116. E-3	6. E-3	12	385.7 E-3
AMMONIA-N	4.6 E0	6.3 E0	2.7 E0	12	56.4 E0	3.9 E0	6.4 E0	1.6 E0	12	44.2 E0
ARSENIC	3.4 E-3	11. E-3	8. E-3	12	41.2 E-3	3.7 E-3	15. E-3	10. E-3	12	41.7 E-3
BARIUM	33.6 E-3	50. E-3	4. E-3	12	407.9 E-3	115.2 E-6	2. E-3	2. E-3	12	1.3 E-3
BERYLLIUM	8.2 E-3	47. E-3	2. E-3	12	99.6 E-3	0	*	*	12	0
BORON	80.6 E-3	140. E-3	20. E-3	12	980.2 E-3	61.6 E-3	98. E-3	31. E-3	12	692.9 E-3
CADMIUM	3.6 E-3	7. E-3	3. E-3	12	43.5 E-3	234.1 E-6	3. E-3	3. E-3	12	2.6 E-3
CALCIUM	11.7 E0	19. E0	8. E0	12	142.2 E0	543.6 E-3	2. E0	130. E-3	12	6.1 E0
CHLORIDE	26.5 E0	77. E0	14. E0	12	322.2 E0	9.9 E0	27. E0	980. E-3	12	112. E0
COBALT	657.5 E-6	3. E-3	1. E-3	12	8. E-3	273.1 E-6	4. E-3	1. E-3	12	3.1 E-3
COD	257.3 E0	1.1 E3	77. E0	12	3.1 E3	32.9 E0	62. E0	18. E0	12	370.1 E0
CONDUCTIVITY**	383.5 E0	809. E0	230. E0	12	4.7 E3	359.6 E0	840. E0	100. E0	12	4. E3
COPPER	861.8 E-3	6. E0	150. E-3	12	10.5 E0	19.3 E-3	40. E-3	10. E-3	12	217.2 E-3
CYANIDE	5.2 E-3	23. E-3	3. E-3	12	63. E-3	990.6 E-6	5. E-3	2. E-3	12	11.2 E-3
FLUORIDE	628.1 E-3	1.4 E0	230. E-3	12	7.6 E0	384.5 E-3	1.4 E0	210. E-3	12	4.3 E0
HARDNESS**	45. E0	76.3 E0	31.5 E0	12	547.2 E0	1.2 E0	5.2 E0	324.6 E-3	12	13.2 E0
IRON	1.3 E0	2.8 E0	780. E-3	12	16.3 E0	62.9 E-3	171. E-3	20. E-3	12	708.2 E-3
LEAD	80.5 E-3	130. E-3	40. E-3	12	978.2 E-3	0	*	*	12	0
MAGNESIUM	3.8 E0	7. E0	2.8 E0	12	46.7 E0	8.1 E-3	50. E-3	40. E-3	12	91.7 E-3
MERCURY	4.4 E-3	9.1 E-3	1.9 E-3	12	53.2 E-3	39.1 E-6	100. E-6	20. E-6	12	440.6 E-6
NICKEL	85.4 E-3	450. E-3	30. E-3	12	1. E0	0	*	*	12	0
NITRATE-N	3.9 E0	9.1 E0	830. E-3	12	47.9 E0	626.8 E-3	4.4 E0	26. E-3	12	7.1 E0
NITRITE-N	722.4 E-3	1.8 E0	171. E-3	12	8.8 E0	505.9 E-3	3.6 E0	100. E-3	12	5.7 E0
PERCHLORATE	141.3 E-3	490. E-3	17. E-3	12	1.7 E0	0	*	*	12	0
PHOSPHORUS	2.2 E0	4.2 E0	28. E-3	12	26.6 E0	47.5 E-3	186. E-3	20. E-3	12	534.2 E-3
POTASSIUM	3.8 E0	11. E0	400. E-3	12	46.3 E0	1.8 E0	7.5 E0	200. E-3	12	20.8 E0
SELENIUM	0	*	*	12	0	0	*	*	12	0
SILICON	30.8 E0	40. E0	11. E0	12	374.7 E0	4. E0	12. E0	610. E-3	12	44.6 E0
SILVER	29.4 E-3	170. E-3	2. E-3	12	357.9 E-3	24.5 E-3	280. E-3	3. E-3	12	276.2 E-3
SODIUM	49.9 E0	140. E0	18. E0	12	606.5 E0	68.1 E0	179. E0	16. E0	12	766.6 E0
SULFATE	27.7 E0	100. E0	10. E0	12	337.1 E0	30.4 E0	98. E0	6. E0	12	342.3 E0
TDS	200.1 E0	478. E0	110. E0	12	2.4 E3	130.5 E0	338. E0	156. E0	12	1.5 E3
TKN	11.1 E0	38.7 E0	3.3 E0	12	134.9 E0	4.6 E0	8.5 E0	2. E0	12	51.8 E0
TOTAL CATIONS**	3.7 E0	8. E0	2.1 E0	12	44.9 E0	3.6 E0	8.8 E0	1.1 E0	12	40.5 E0
TOTAL CHROMIUM	33.5 E-3	70. E-3	23. E-3	12	406.7 E-3	78. E-6	1. E-3	1. E-3	12	878.4 E-6
TOXIC ORGANICS**						789.6 E-3	1.9 E0	1. E0	12	899 E0
TSS	29.2 E0	58. E0	11. E0	12	355.2 E0	0	*	*	12	0
URANIUM	98.6 E-3	147. E-3	56. E-3	12	1.2 E0	69.4 E-6	400. E-6	320. E-6	12	781.8 E-6
VANADIUM	39.4 E-3	220. E-3	10. E-3	12	479.6 E-3	12.9 E-3	150. E-3	20. E-3	12	145.6 E-3
ZINC	142.4 E-3	190. E-3	20. E-3	12	1.7 E0	7.5 E-3	30. E-3	9. E-3	12	83.9 E-3
pH	7.1 E0	9.1 E0	6.2 E0	12	85.9 E0	7.4 E0	8. E0	7. E0	12	83.7 E0

Volume of Flow: Influent = 12156083 liters Final = 11257314 liters

\*\*Alkalinities and hardness as mg CaCO3/l; Conductivity as uS/cm; Total Cations as meq/l; Toxic Organics as ug/l; Otherwise: mg/l.  
\* Less than Detection Limit

Issued 02/11/2004 16:24:29

The following series of eight (8) figures highlight significant information which pertains to the non-radiological nature of the TA-50 RLWTF influent and effluent.

The upper graph in Figure 5-1 shows the silicon, Si, concentration in the raw daily influent water to the RLWTF and the silicon concentration in the effluent from the RLWTF in monthly composite samples during CY 2003. The lower graph in Figure 5-1 shows the total dissolved solids, TDS, concentration in the raw daily influent water to the RLWTF and the TDS concentration in the effluent from the RLWTF in monthly composite samples during CY 2003.

The upper graph in Figure 5-2 shows the potassium concentration in the raw daily influent water to the RLWTF and the potassium concentration in the effluent from the RLWTF in monthly composite samples during CY 2003. The lower graph in Figure 5-2 shows the sodium concentration in the raw daily influent water to the RLWTF and the sodium concentration in the effluent from the RLWTF in monthly composite samples during CY 2003.

The upper graph in Figure 5-3 shows the chemical oxygen demand, COD, concentration in the raw daily influent water to the RLWTF and the COD concentration in the effluent from the RLWTF in monthly composite samples during CY 2003. The lower graph in Figure 5-3 shows the calcium concentration in the raw daily influent water to the RLWTF and the calcium concentration in the effluent from the RLWTF in monthly composite samples during CY 2003.

The upper graph in Figure 5-4 shows the iron concentration in the raw daily influent water to the RLWTF and the iron concentration in the effluent from the RLWTF in monthly composite samples during CY 2003. The lower graph in Figure 5-4 shows more detail on the iron concentration in the CY 2003 effluent.

The upper graph in Figure 5-5 shows the mercury concentration in the raw daily influent water to the RLWTF and the mercury concentration in the effluent from the RLWTF in monthly composite samples during CY 2003. The lower graph in Figure 5-5 shows more detail on the mercury concentration in the CY 2003 effluent.

Figure 5-1 Silicon and TDS in the RLWTF Influent and Effluent During CY 2003

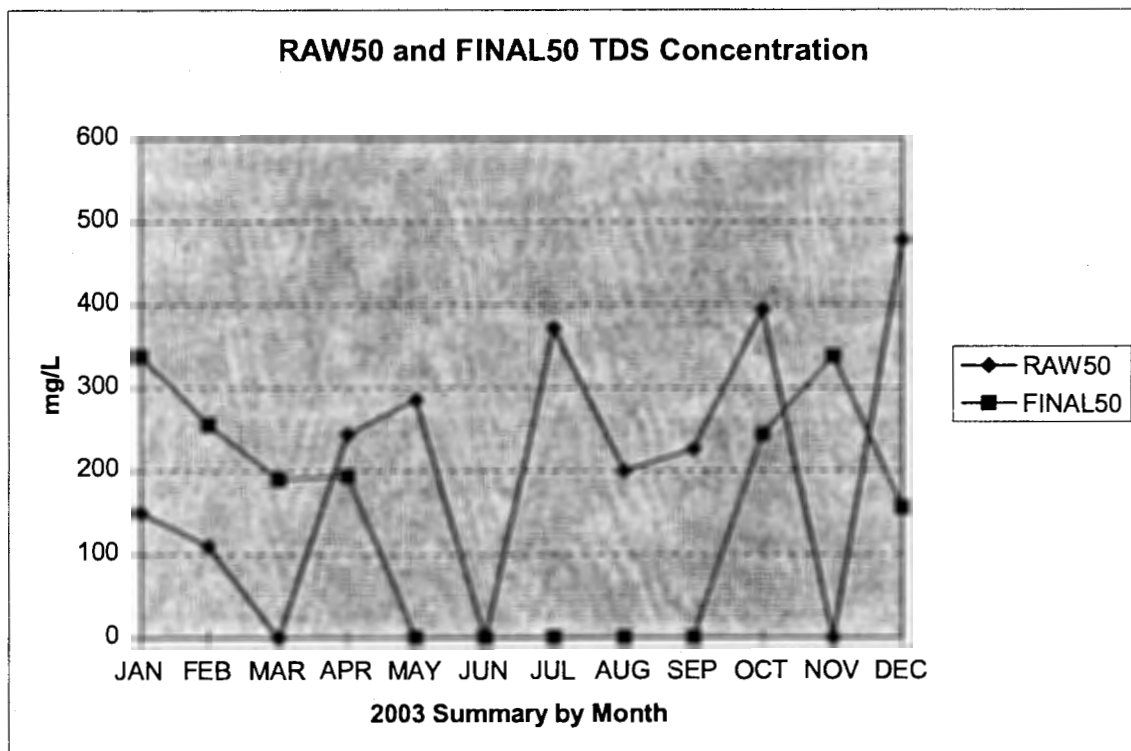
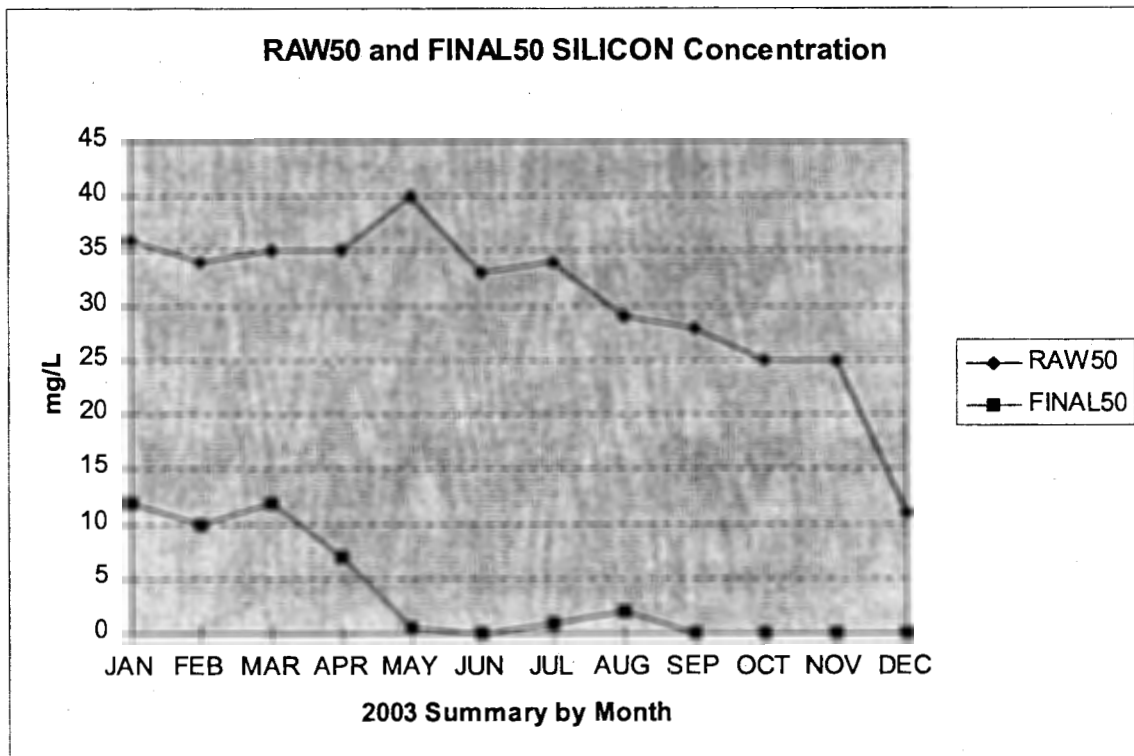

Figure 5-2 Potassium and Sodium in the RLWTF Influent and Effluent During CY 2003

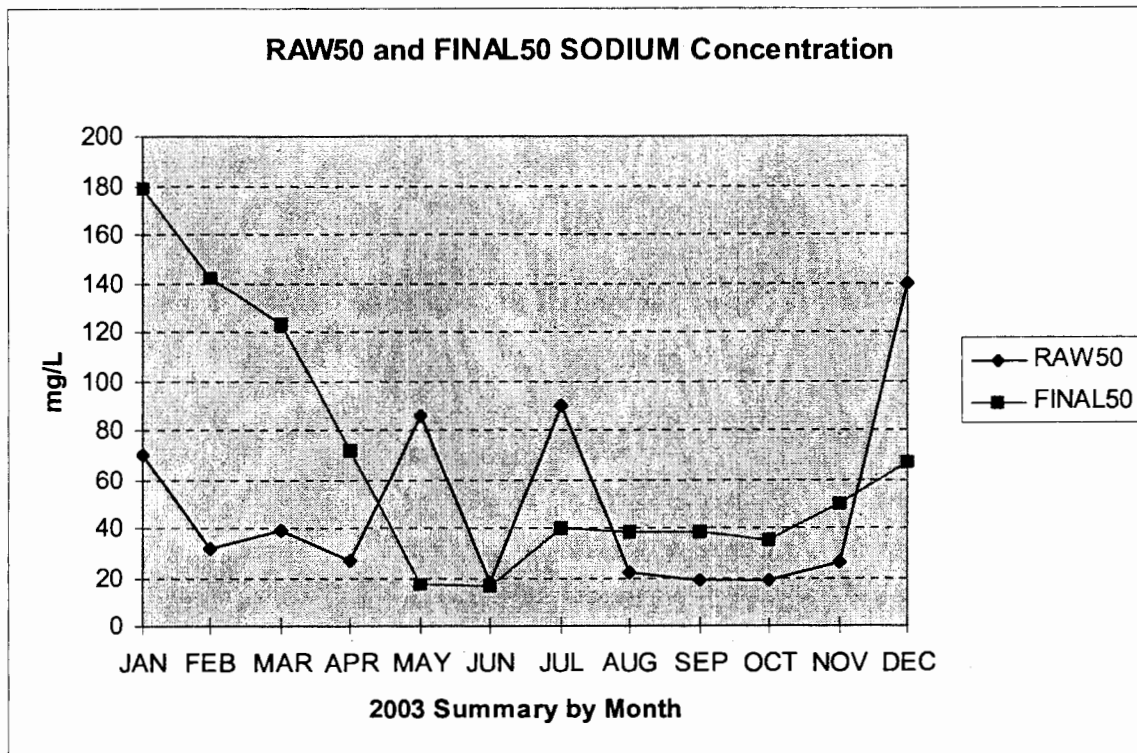
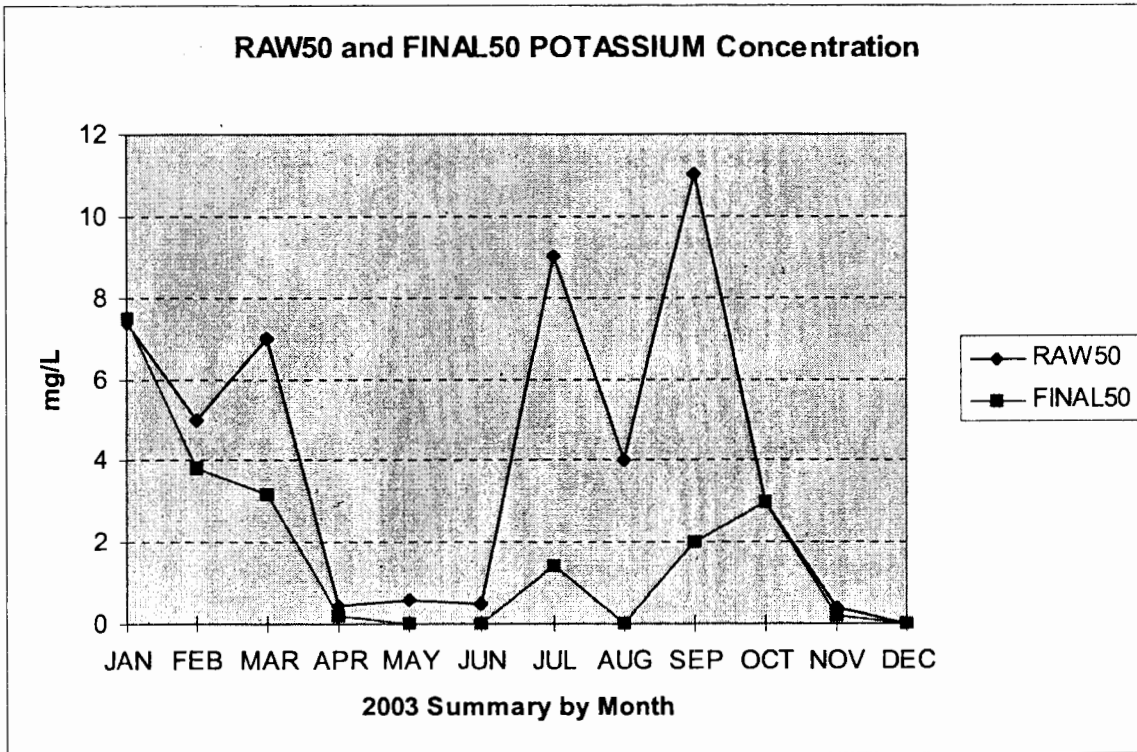

Figure 5-3 COD and Calcium in the RLWTF Influent and Effluent During CY 2003

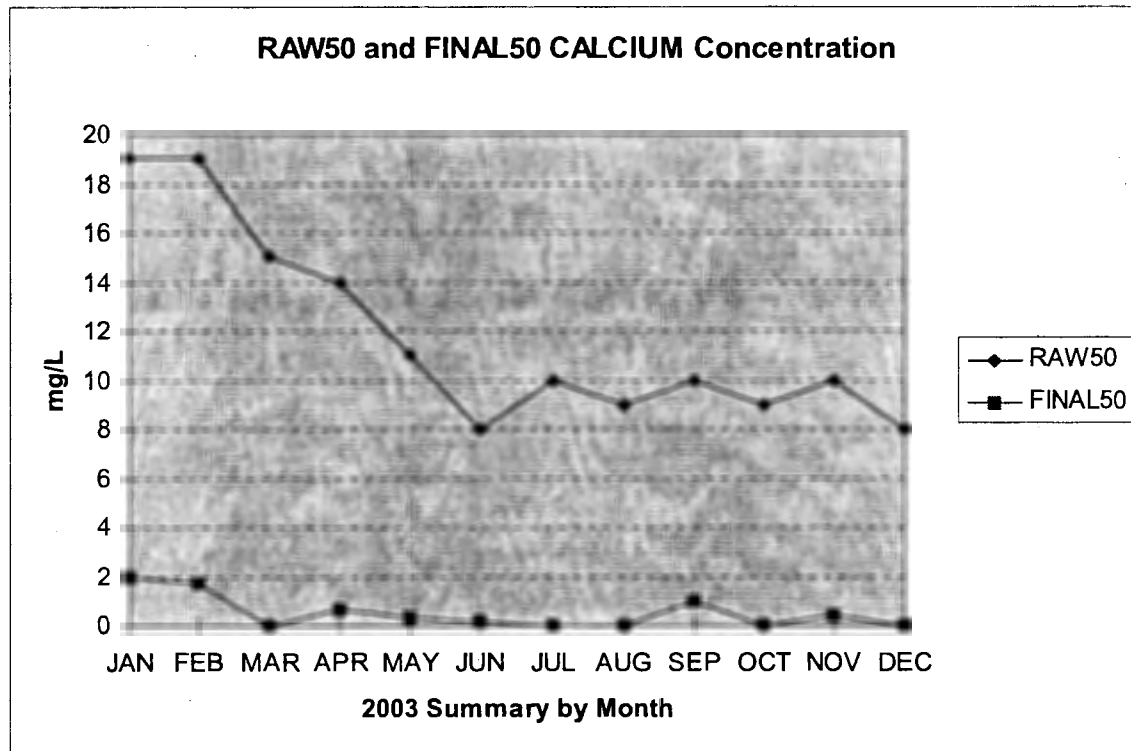
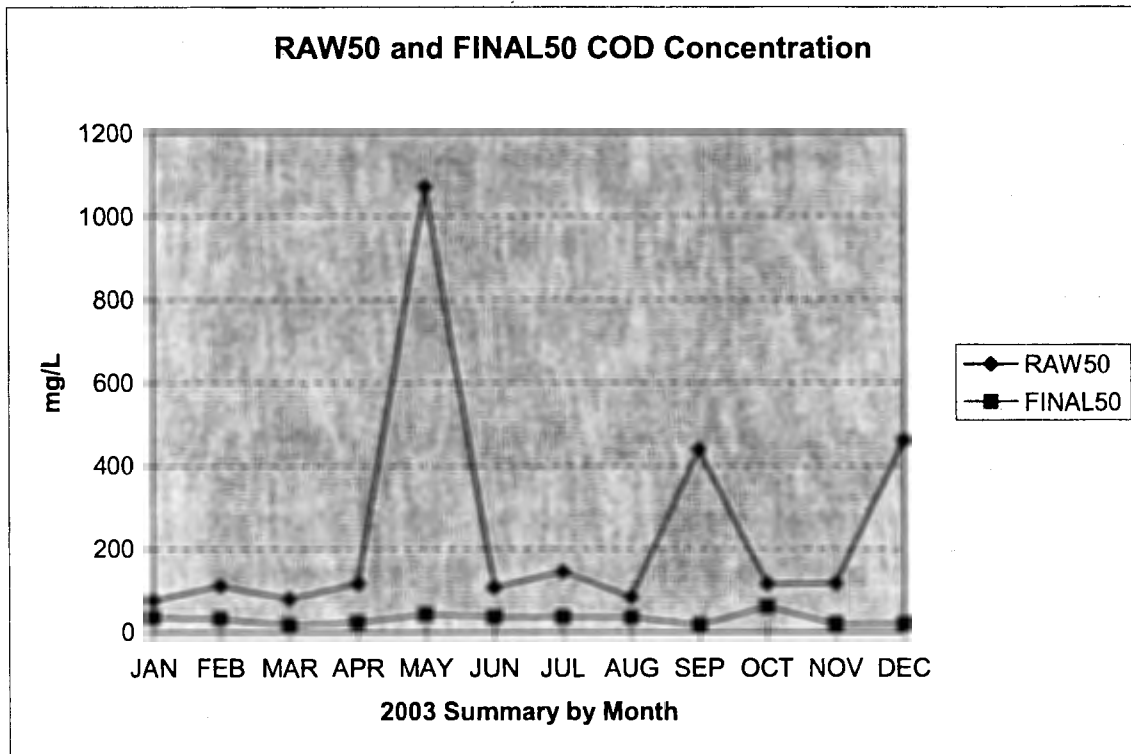



Figure 5-4 Iron in the RLWTF Influent and Effluent During CY 2003

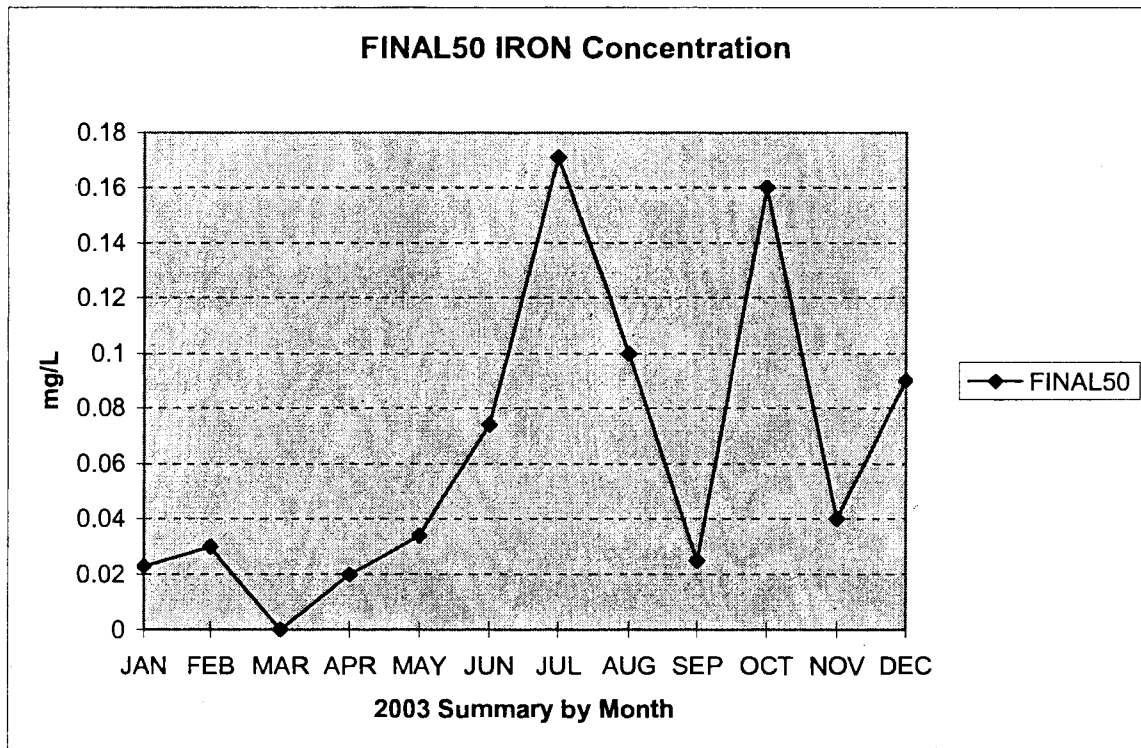
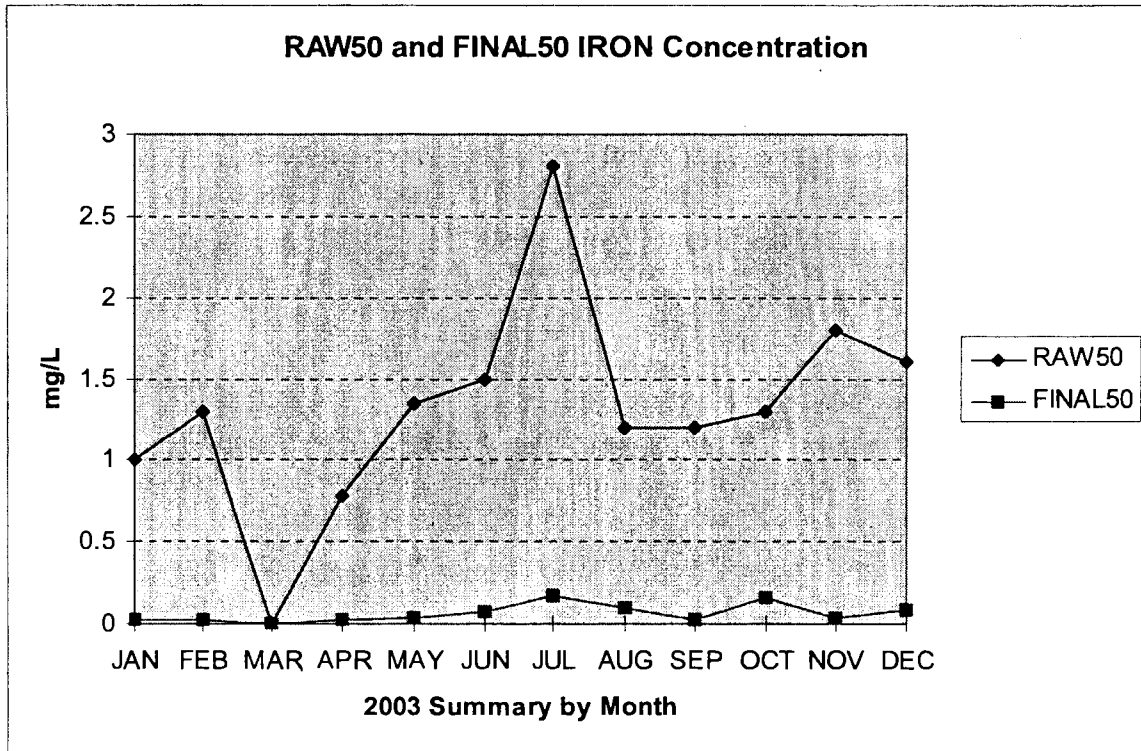
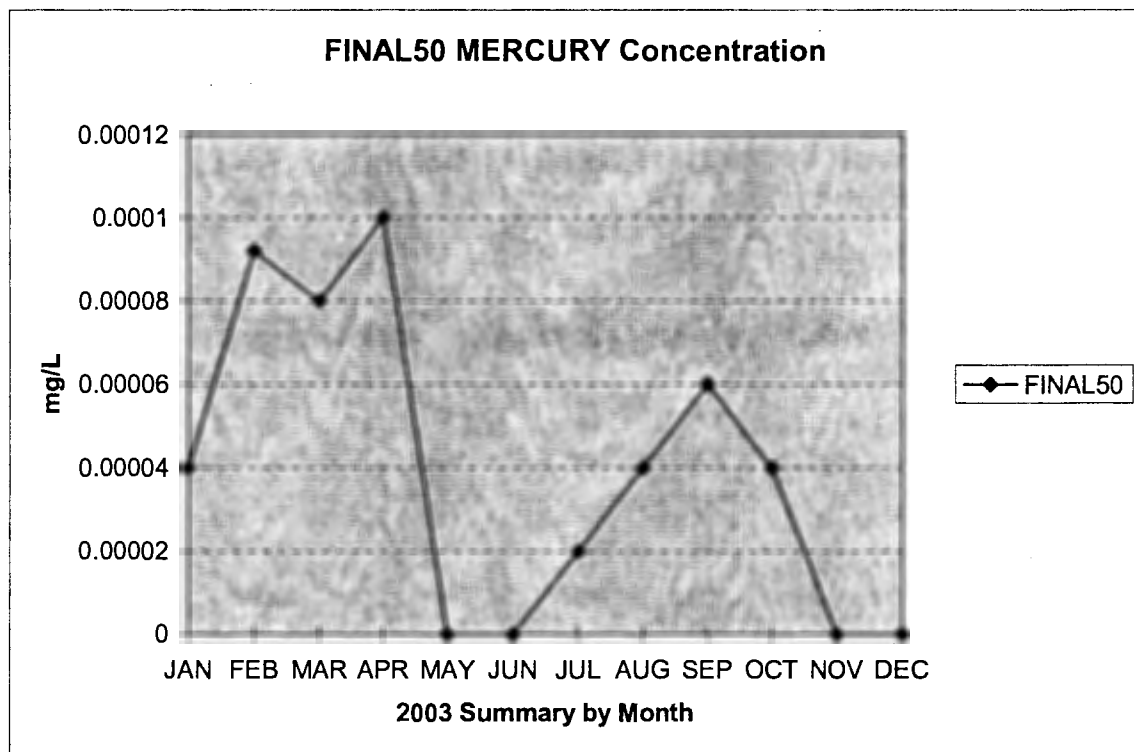
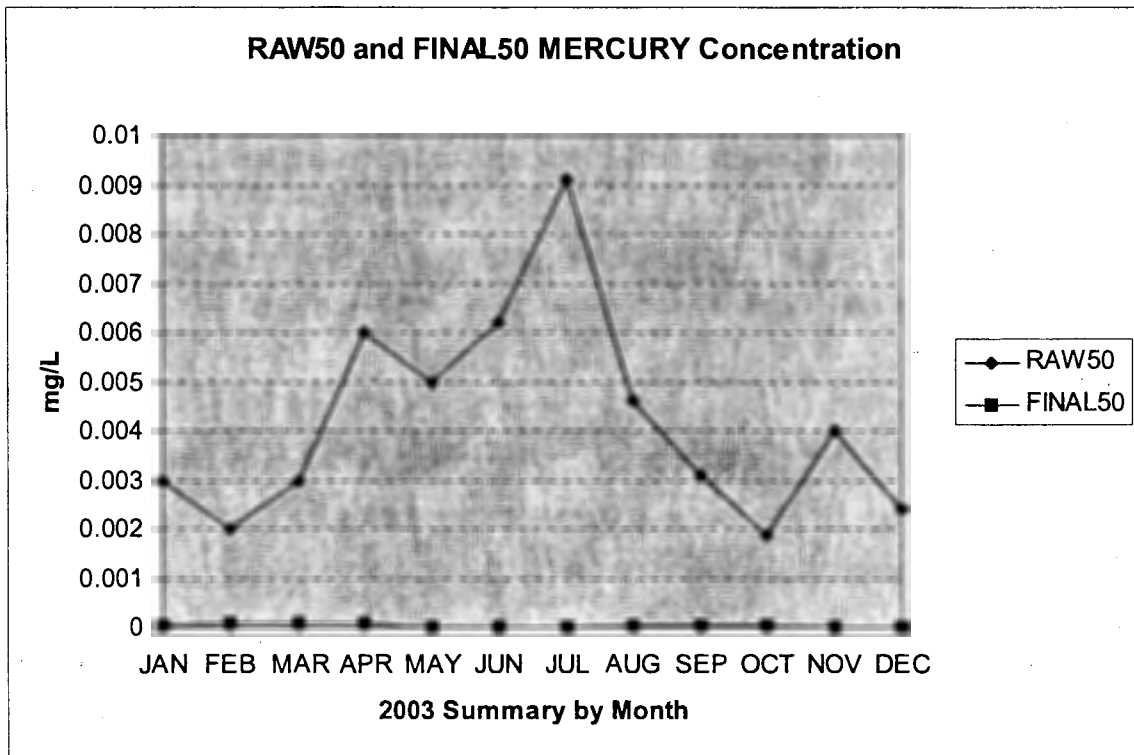

Figure 5-5 Mercury in the RLWTF Influent and Effluent During CY 2003



The upper graph in Figure 5-6 shows the zinc concentration in the raw daily influent water to the RLWTF and the zinc concentration in the effluent from the RLWTF in monthly composite samples during CY 2003. The lower graph in Figure 5-6 shows the fluoride concentration in the raw daily influent water to the RLWTF and the fluoride concentration in the effluent from the RLWTF in monthly composite samples during CY 2003.

The upper graph in Figure 5-7 shows the perchlorate concentration in the raw daily influent water to the RLWTF and the perchlorate concentration in the effluent from the RLWTF in monthly composite samples during CY 2003. The lower graph in Figure 5-7 shows the methyl orange alkalinity concentration in the raw daily influent water to the RLWTF and the methyl orange alkalinity concentration in the effluent from the RLWTF in monthly composite samples during CY 2003.

The upper graph in Figure 5-8 shows the ammonia-nitrogen concentration in the raw daily influent water to the RLWTF and the ammonia-nitrogen concentration in the effluent from the RLWTF in monthly composite samples during CY 2003. The lower graph in Figure 5-8 shows the nitrate-nitrogen concentration in the raw daily influent water to the RLWTF and the nitrate-nitrogen concentration in the effluent from the RLWTF in monthly composite samples during CY 2003.

Figure 5-6 Zinc and Fluoride in the RLWTF Influent and Effluent During CY 2003

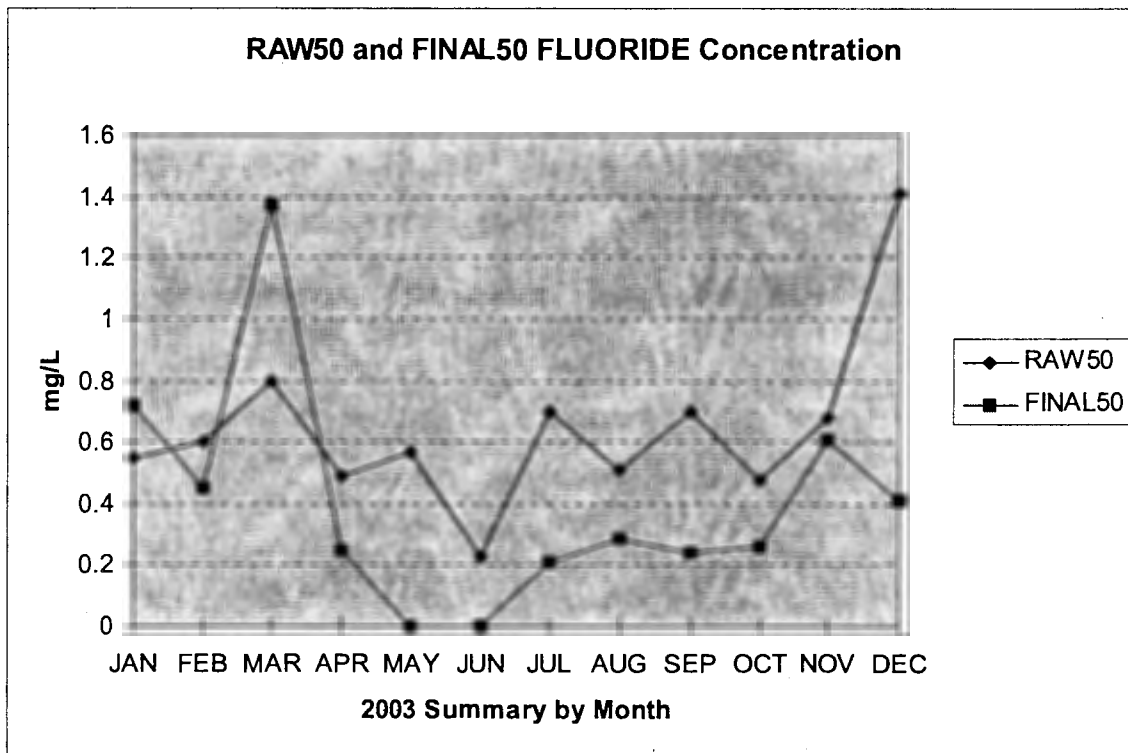
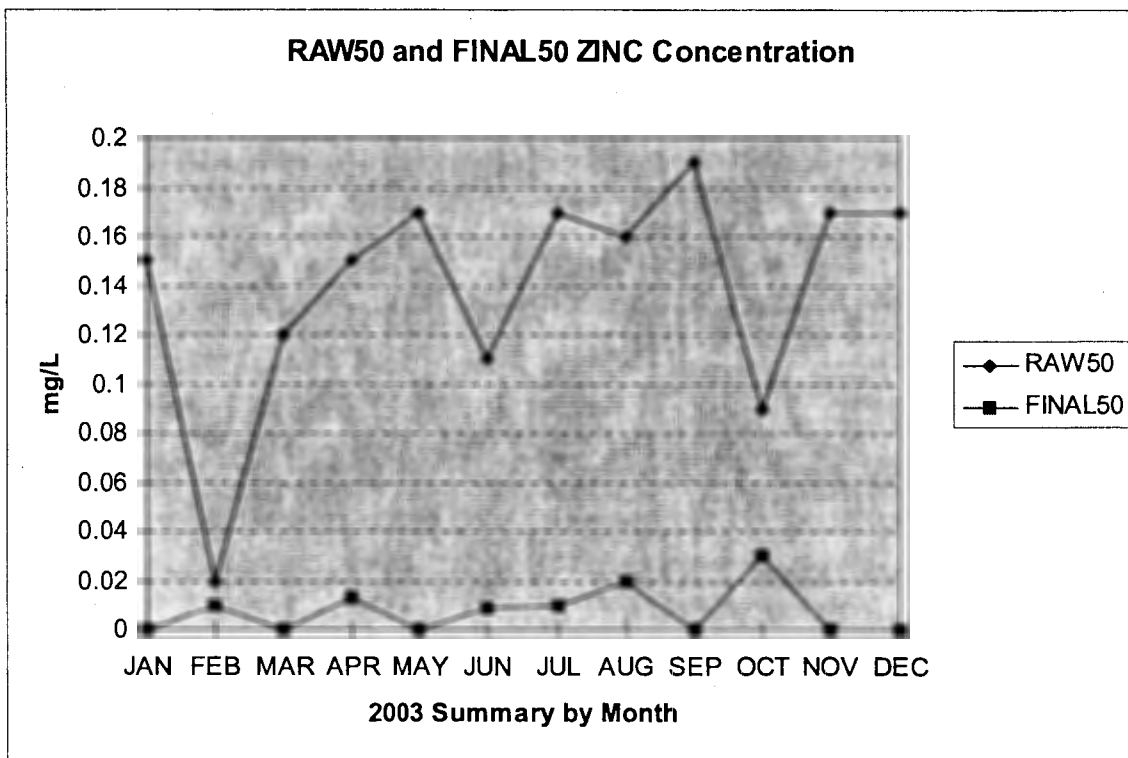

Figure 5-7 Perchlorate and Total Alkalinity in the RLWTF Influent and Effluent During CY 2003

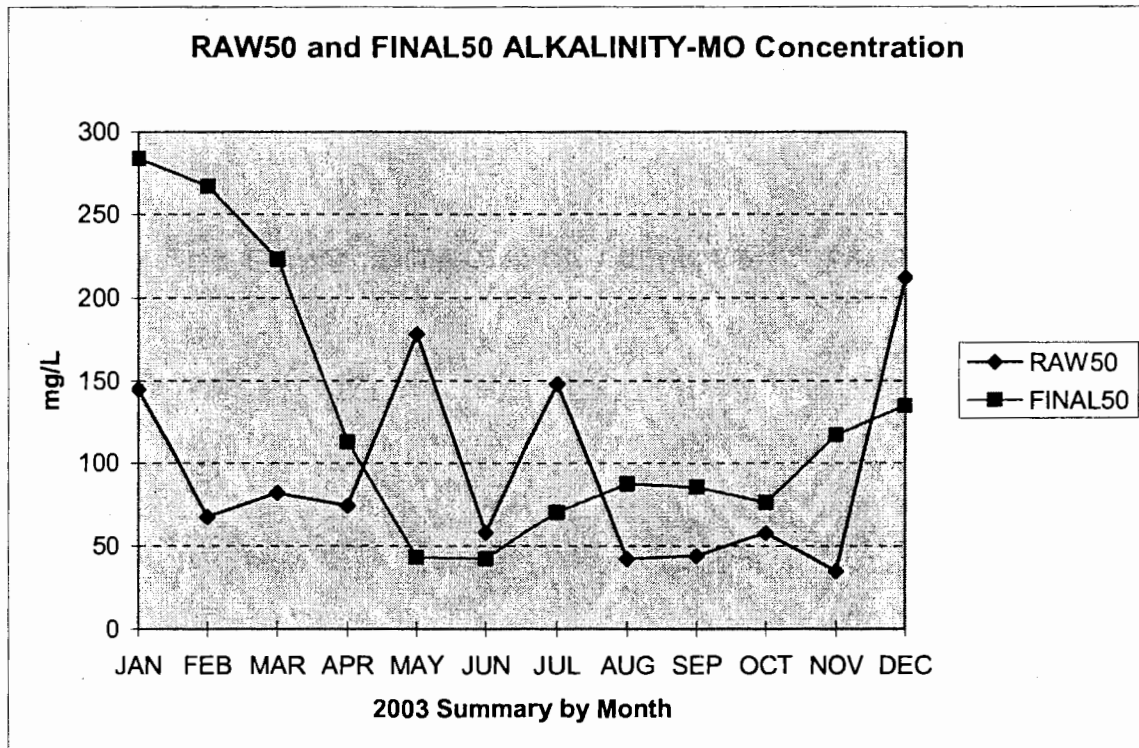
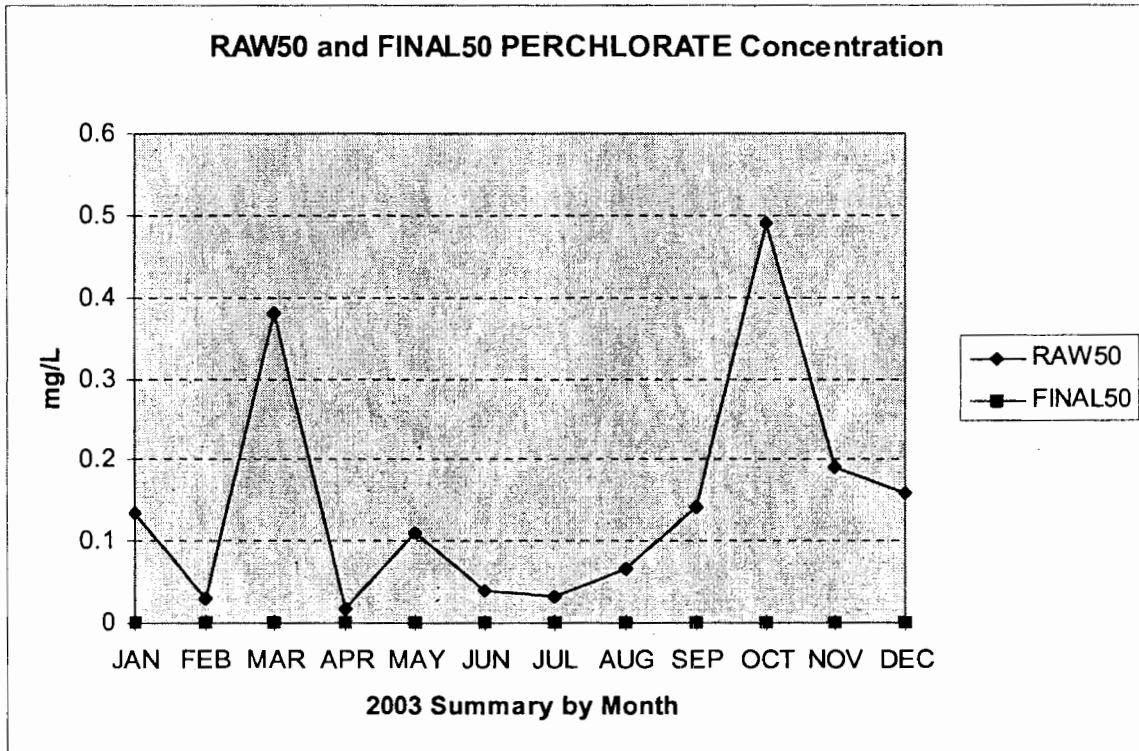
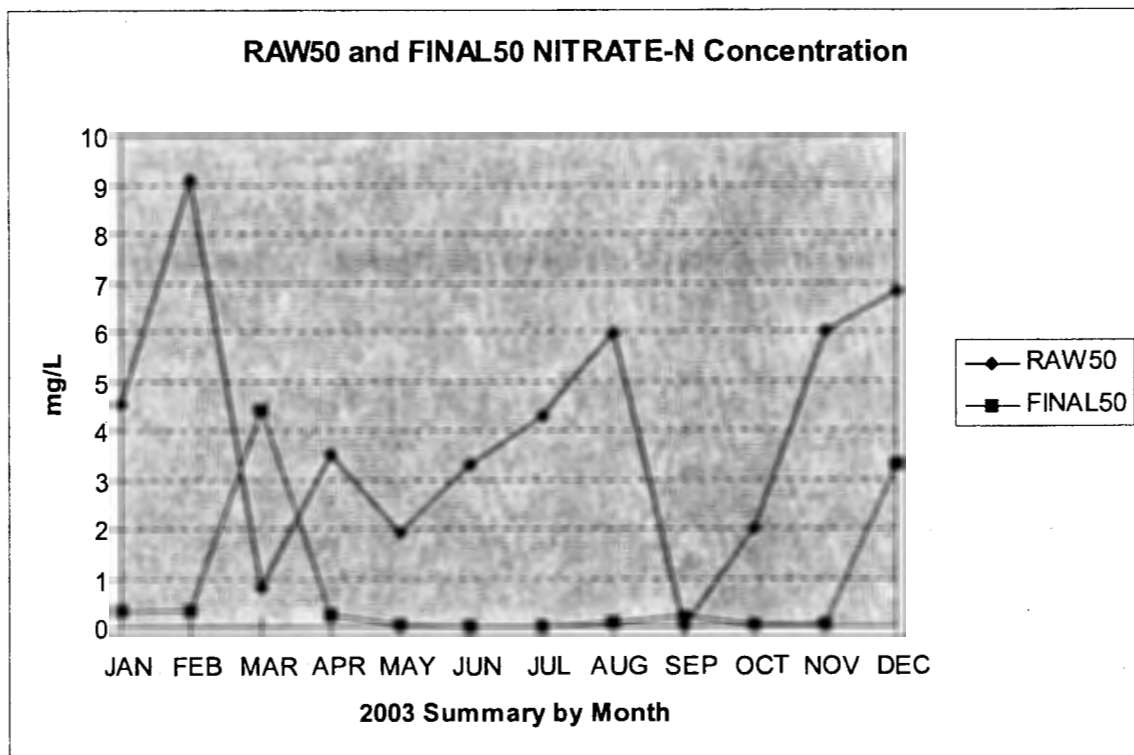
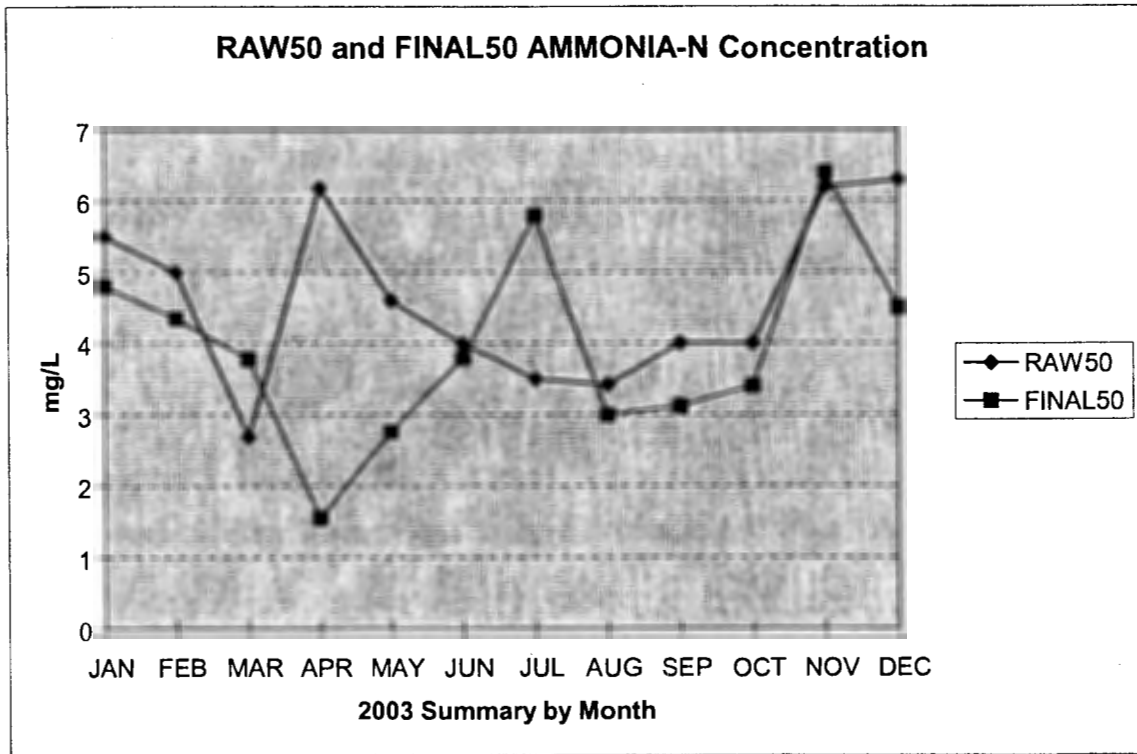

Figure 5-8 Ammonia-Nitrogen and Nitrate-Nitrogen in the RLWTF Influent and Effluent During CY 2003



Volatile organic chemicals (VOC) and semi-volatile organic chemicals (SVOC) are also analyzed for in the TA-50 RLWTF influent wastewaters, treated effluent waters and in the chemical sludge produced by the clarification process. A grab sample of influent water is analyzed for VOC/SVOC on a weekly basis. A monthly grab sample of effluent water is analyzed for VOC/SVOC. Additionally, individual batches of sludge are also analyzed for VOC/SVOC. These analyses are performed according to EPA approved methods 624, 625A and 625B by an external EPA certified laboratory.

Table 5-5 shows the VOC/SVOC detected in the RLWTF influent and the number of weeks in which that chemical was detected during CY 2003. More information pertaining to VOC/SVOC in the RLWTF influent is given in Appendices E, F, G and H.

Table 5-5 VOC/SVOC Detected in Weekly Samples of 2003 RLWTF Influent

<b>VOC/SVOC Detected in the RLWTF Weekly Influent Samples</b>			
JAN-2003 through DEC-2003			
VOC (Method 624)	Weeks	Low (mg/L)	High (mg/L)
1,2,3-TRICHLOROBENZENE	1	2.6 E-3	2.6 E-3
1,2,4-TRIMETHYLBENZENE	15	840. E-6	11. E-3
1,2-DICHLOROBENZENE	1	1. E-3	1. E-3
1,2-DICHLOROETHANE	2	490. E-6	30. E-3
1,2-XYLENE	3	510. E-6	3. E-3
1,3,5-TRIMETHYLBENZENE	1	650. E-6	650. E-6
1,3-XYLENE+XYLENE[1,4-]	2	1. E-3	10. E-3
2-BUTANONE	5	7. E-3	15. E-3
4-ISOPROPYLTOLUENE	1	890. E-6	890. E-6
4-METHYL-2-PENTANONE	16	2.4 E-3	340. E-3
ACETONE	49	78. E-3	3.1 E0
BROMOBENZENE	3	820. E-6	1.7 E-3
BROMOMETHANE	1	3.5 E-3	3.5 E-3
CHLOROFORM	39	360. E-6	6. E-3
CHLOROMETHANE	4	260. E-6	3.9 E-3
CIS-1,2-DICHLOROETHENE	1	1.6 E-3	1.6 E-3
CIS/TRANS-1,2-DICHLOROETHENE	1	1.6 E-3	1.6 E-3
DI-N-OCTYL PHTHALATE	1	2.8 E-3	2.8 E-3
ETHYLBENZENE	2	1. E-3	3. E-3
HEXACHLOROBUTADIENE	1	2. E-3	2. E-3
ISOPROPYLBENZENE	1	760. E-6	760. E-6
METHYL TERT-BUTYL ETHER	1	76. E-3	76. E-3
METHYLENE CHLORIDE	45	790. E-6	66. E-3
N-NITROSO-DI-N-PROPYLAMINE	3	7.5 E-3	46. E-3
SEC-BUTYLBENZENE	1	900. E-6	900. E-6
STYRENE	1	640. E-6	640. E-6
TERT-BUTYLBENZENE	1	820. E-6	820. E-6
TOLUENE	3	1.2 E-3	14. E-3
TRICHLOROETHENE	1	4. E-3	4. E-3
XYLENE (TOTAL)	3	1.7 E-3	13. E-3
XYLENE[1,3-]+XYLENE[1,4-]	2	1.2 E-3	4.3 E-3

SVOC (Methods 625A and 625B)	Weeks	Low (mg/L)	High (mg/L)
2-NITROPHENOL	3	2. E-3	3.3 E-3
3-METHYLPHENOL & 4-METHYLPHENOL	3	2. E-3	3.3 E-3
BENZOIC ACID	31	2.7 E-3	430. E-3
BENZYL ALCOHOL	7	2. E-3	210. E-3
BIS(2-ETHYLHEXYL)PHTHALATE	41	2.8 E-3	130. E-3
BUTYLBENZYLPHTHALATE	3	2. E-3	3. E-3
DI-N-BUTYLPHTHALATE	1	3. E-3	3. E-3
DIETHYLPHTHALATE	12	2. E-3	9. E-3
N-NITROSO-DI-N-PROPYLAMINE	3	3.7 E-3	54. E-3
N-NITROSODIMETHYLAMINE	1	4. E-3	4. E-3
PHENOL	13	2. E-3	370. E-3
PYRIDINE	21	5.1 E-3	100. E-3

Issued 02/17/2004 15:02:10

Table 5-6 summarizes the VOC/SVOC detected in the RLWTF effluent during CY 2003 and the concentration range of these chemicals. The “months” column in Table 5-6 indicates the number of monthly samples in which a particular chemical was detected. For example, the VOC chemical, chloroform, was detected in very small concentrations in six (6) of the twelve (12) monthly effluent samples. Of the SVOC chemicals, only chrysene was detected in one (1) monthly effluent sample.

Table 5-6 VOC/SVOC Detected in Monthly Samples of 2003 RLWTF Effluent

VOC/SVOC Detected in the RLWTF Monthly Effluent Samples			
JAN-2003 through DEC-2003			
VOC (Method 624)	Months	Low (ug/L)	High (ug/L)
Chloroform	6	1.1 E0	1.9 E0
SVOC (Methods 625A and 625B)	Months	Low (ug/L)	High (ug/L)
Chrysene	1	1. E0	1. E0

Issued 02/17/2004 13:54:27



Table 5-7 summarizes the VOC/SVOC chemicals detected in the RLWTF sludge during CY 2003 and the range of concentrations of these chemicals. Additional information pertaining to VOC/SVOC in the RLWTF sludge is given in Appendices I, J, K and L.

Table 5-7 VOC/SVOC Detected in Samples of 2003 RLWTF Sludge

<b>VOC/SVOC Detected in the RLWTF Sludge Samples</b>		
JAN-2003 through DEC-2003		
VOC (Method 624)	Low (mg/L)	High (mg/L)
1,1,2-TRICHLORO-1,2,2-TRIFLUORO	1. E-3	1. E-3
1,1,2-TRICHLORO-1,2,2-TRIFLUOROETHANE	4.5 E-3	4.5 E-3
1,2,4-TRIMETHYLBENZENE	7.9 E-3	48. E-3
1,2-DICHLOROBENZENE	2. E-3	2. E-3
1,3,5-TRIMETHYLBENZENE	4. E-3	4. E-3
1,3-DICHLOROBENZENE	2. E-3	2. E-3
1,4-DICHLOROBENZENE	2. E-3	2. E-3
2-BUTANONE	24. E-3	270. E-3
4-ISOPROPYLTOLUENE	2. E-3	2. E-3
4-METHYL-2-PENTANONE	3.8 E-3	23. E-3
ACETONE	21. E-3	820. E-3
CARBON DISULFIDE	4. E-3	18. E-3
DI-N-OCTYL PHTHALATE	1.2 E0	1.7 E0
DICHLORODIFLUOROMETHANE	6. E-3	6. E-3
ETHYLBENZENE	1.3 E-3	6. E-3
METHYLENE CHLORIDE	8.6 E-3	69. E-3
SEC-BUTYLBENZENE	2. E-3	2. E-3
STYRENE	630. E-6	630. E-6
TETRACHLOROETHENE	1.3 E-3	17. E-3
TOLUENE	2. E-3	7. E-3
XYLENE (TOTAL)	3.7 E-3	25. E-3
SVOC (Methods 625A and 625B)	Low (mg/L)	High (mg/L)
BIS(2-ETHYLHEXYL)PHTHALATE	8.5 E0	24. E0

Issued 02/17/2004 15:36:17

## 6. Summary of CY 2003 Operations at the TA-21 RLWTP

The TA-21 Radioactive Liquid Waste Treatment Plant (RLWTP) historically treated radioactive liquid waste from a number of facilities at TA-21. Presently, the TA-21 RLWTP treats limited volumes of radioactive liquid waste generated from tritium research at TA-21 using three (3) treatment processes (clarifier, sand filter and sludge vacuum filtration). The TA-21 plant is physically separated from the radioactive liquid waste collection system, which conveys water to the main TA-50 RLWTF.

During CY 2003, the TA-21 RLWTP received 32,480 liters of influent wastewater. The plant was operated once during CY 2003, in August, and treated 24,640 liters of radioactive liquid waste at that time. The volumes of received and treated water are not identical due to stored volumes of RLW in the influent tanks at the TA-21 RLWTP. The water treated in CY 2003 is presently in the effluent tanks at the TA-21 RLWTP. Sludge was not treated in the vacuum filter at TA-21 during CY 2003. As a result, no drums of dewatered sludge were generated or shipped to TA-54 for disposal.

Effluent from the TA-21 RLWTP is normally trucked to the TA-50 RLWTF for additional treatment to remove alpha particle radioactivity. During CY 2003 no treated effluent from the TA-21 RLWTP was trucked to the TA-50 RLWTF. Some treated effluent, 7,600 liters, was trucked from the TA-21 RLWTP to the TA-53 solar evaporation RLWTF due to elevated concentrations of tritium.

Tables 6-1 and 6-2 summarize the radiological and mineral constituents in the 24,640 liters of water treated at the TA-21 RLWTP during January 2003. The "Total (Ci)" column in Table 6-1 and the "Total (kg)" column in Table 6-2 display zeroes for each radioisotope and each mineral constituent. This is because the influent flow meters at the TA-21 RLWTP recorded no flow during January 2003. The 24,640 liters of RLW treated in January 2003 came from the TA-21 RLWTP influent holding tanks. The total curies of radioisotopes and the total kilograms of mineral constituents can be determined by multiplying the activities and concentrations of constituents in Tables 6-1 and 6-2 by 24,640 liters.

Table 6-1 Radioisotopes in August 2003 Sample of TA-21 Influent

<b>TA21 RADIOISOTOPES</b>		
Summary for AUG-2003		
	RAW nCi/L	RAW Total (Ci)
ALPHA	52. E0	0
Am-241	18. E0	0
BETA	16. E0	0
Cs-137	*	0
Pu-238	9. E0	0
Pu-239	24. E0	0
Sr-89	*	0
Sr-90	*	0
TRITIUM	20. E3	0
Th-232	780. E-6	0
U-234	188. E-3	0
U-235	7.5 E-3	0
U-238	4.5 E-3	0
Volume of Flow: Influent = 0 liters Transferred = 0 liters		
* Less than Detection Limit.		
Issued 01/06/2004 14:39:28		

Table 6-2 Minerals in August 2003 Sample of TA-21 Influent

<b>TA21 MINERALS</b>		
Summary for AUG-2003		
	RAW Concentration	Total (Kg)
ALKALINITY-MO**	459. E0	0
ALKALINITY-P**	*	
ALUMINIUM	2. E0	0
AMMONIA-N	2. E0	0
ARSENIC	*	
BARIUM	115. E-3	0
BERYLLIUM	*	
BORON	*	
CADMIUM	28. E-3	0
CALCIUM	103. E0	0
CHLORIDE	60. E0	0
COBALT	5. E-3	0
COD	293. E0	0
CONDUCTIVITY**	915. E0	
COPPER	174. E-3	0
CYANIDE	*	
FLUORIDE	7.5 E0	0
HARDNESS**	290.1 E0	0
IRON	32. E0	0
LEAD	6. E0	0
MAGNESIUM	8. E0	0
MERCURY	6.7 E-3	0
NICKEL	89. E-3	0
NITRATE-N	730. E-3	0
NITRITE-N	*	
PERCHLORATE	*	
PHOSPHORUS	170. E-3	0
POTASSIUM	28. E0	0
SELENIUM	*	
SILICON	30. E0	0
SILVER	*	
SODIUM	84. E0	0
SULFATE	19. E0	0
TDS	620. E0	0
TKN	3.5 E0	0
TOTAL CATIONS**	12.3 E0	
TOTAL CHROMIUM	71. E-3	0
TSS	300. E0	0
URANIUM	13.9 E-3	0
VANADIUM	30. E-3	0
ZINC	500. E-3	0
pH	7. E0	

Volume of Flow: Influent = 0 liters Transferred = 0 liters

\*\*Alkalinities and hardness as mg CaCO3/l; Conductivity as uS/cm; Total Cations as meq/l; Otherwise: mg/l.

\* Less than Detection Limit

Issued 01/06/2004 14:39:34

## 7. Summary of CY 2003 Operations at the TA-53 RLWTP

The TA-53 RLWTP treats radioactive liquid waste from accelerator research at the Los Alamos Neutron Science Center. The treatment process includes wastewater storage to allow short-lived radioisotope decay and solar evaporation. Operations at the TA-53 RLWTP started in December 1999.

During CY 2003 the TA-53 RLWTP received 157,483 liters of wastewater from accelerator research at the Los Alamos Neutron Science Center. Additionally during CY 2003, 6,813 liters of wastewater were trucked to the TA-53 RLWTP from the Omega West Facility (TA-2), 3,785 liters from the Weapons Engineering Tritium Facility (WETF) at TA-16, 7,600 liters from the TA-21 radioactive liquid waste treatment plant, and 217,640 liters of water from the TA-50 RLWTF. These trucked wastewaters met the waste acceptance criteria for the TA-53 RLWTP.

During CY 2003, 325,013 liters of water was pumped from the storage tanks for solar evaporation in the basins at the TA-53 RLWTP.

**Appendix A**

**TA-50 RLWTF Monthly Flow Summary for CY 2003**

**TA50 MONTHLY FLOWS (liters)**

JAN-2003 through DEC-2003

	Influent	Treated	Time (hrs)	Rate (liters/min)	Effluent	DP	Misc	Recirc	Sludge Processed	Sludge Added	Decant
<b>Jan-03</b>											
Total	1150951	1343481	100		1182460	0	0	174573	801	7509	8538
Maximum Day	253717	100330	7.1	980.42	149100	0	0	72782	267	7509	4269
Minimum Day	4691	27994	1.08	111.06	68900	0	0	8577	267	7509	4269
Average Day	37127	63975	4.76	254.88	78831	0	0	43643	267	7509	4269
<b>Feb-03</b>											
Total	727717	800008	68.7		813300	0	0	175482	11621	22682	0
Maximum Day	83464	90023	7.38	310.59	75300	0	0	81436	2135	22682	0
Minimum Day	5732	7036	1.3	30.07	70900	0	0	5348	939	22682	0
Average Day	25990	53334	4.58	200.45	73936	0	0	35096	1453	22682	0
<b>Mar-03</b>											
Total	903048	972285	76.8		965000	0	0	211543	9545	11741	5070
Maximum Day	57573	101265	7.57	339.66	76100	0	0	43732	2668	11741	5070
Minimum Day	4037	39720	2.5	135.25	72500	0	0	535	267	11741	5070
Average Day	29131	64819	5.12	217.65	74231	0	0	17629	682	11741	5070
<b>Apr-03</b>											
Total	1048828	1219222	86.66		1025100	0	0	236651	10140	15210	14409
Maximum Day	75117	97899	7.23	770.03	148800	0	0	61355	2135	15210	14409
Minimum Day	2808	26797	0.58	139.66	63300	0	0	5348	267	15210	14409
Average Day	34961	64170	4.56	275.63	78854	0	0	26295	922	15210	14409
<b>May-03</b>											
Total	1259010	1211411	110.44		958000	0	0	209945	13342	15210	0
Maximum Day	116849	89799	8.52	547.84	145600	0	0	67846	2135	15210	0
Minimum Day	14600	31319	1.83	118.36	72000	0	0	9804	267	15210	0
Average Day	40613	60571	5.52	196.85	79833	0	0	34991	1026	15210	0
<b>Jun-03</b>											
Total	1278221	2061843	139.48		1472800	0	0	626038	13608	21081	8005
Maximum Day	121426	150014	9.43	3213.67	149000	0	0	145181	2668	10941	4803
Minimum Day	3217	42502	0.5	108.92	66100	0	0	5348	267	2935	3202
Average Day	42607	89645	6.06	405.84	81822	0	0	41736	1134	7027	4002
<b>Jul-03</b>											
Total	1047767	1350333	118.03		1218800	0	0	265953	12276	13608	17345
Maximum Day	90855	115809	7.25	887.4	77400	0	0	62786	2135	8005	8005
Minimum Day	7652	24434	1.25	94.05	74400	0	0	12478	267	1067	4003
Average Day	33799	61379	5.36	218.64	76175	0	0	29550	944	4536	5782

	Influent	Treated	Time (hrs)	Rate (liters/min)	Effluent	DP	Misc	Recirc	Sludge Processed	Sludge Added	Decant
<b>Aug-03</b>											
Total	993992	955923	100.62		878354	0	0	10696	13609	36024	3202
Maximum Day	105042	98211	9.97	222.24	77000	0	0	8913	2668	15210	3202
Minimum Day	9806	14884	3.42	45.77	72630	0	0	1783	267	6938	3202
Average Day	32064	56231	5.92	161.15	73196	0	0	5348	851	12008	3202
<b>Sep-03</b>											
Total	871207	807455	77.67		888000	0	0	73532	15213	0	5871
Maximum Day	81974	68270	6.17	229.74	74000	0	0	32532	2402	0	5871
Minimum Day	111	3425	2.75	13.18	74000	0	0	12478	267	0	5871
Average Day	29040	44859	4.31	173.28	74000	0	0	18383	1014	0	587
<b>Oct-03</b>											
Total	844081	1235795	92.4		648200	0	0	600712	8806	28285	0
Maximum Day	131121	111513	7.37	479.01	73800	0	0	73236	1601	14409	0
Minimum Day	1011	1293	1	21.55	69200	0	0	10874	267	6671	0
Average Day	27228	58847	4.4	225.12	72022	0	0	33373	881	9428	0
<b>Nov-03</b>											
Total	1098827	998067	73.76		725600	0	0	318886	9339	0	11207
Maximum Day	258843	108947	8.67	628.43	144200	0	0	91073	1868	0	11207
Minimum Day	2975	18542	2.33	91.7	71200	0	0	4281	267	0	11207
Average Day	36628	71290	5.27	257.49	80622	0	0	35432	1167	0	11207
<b>Dec-03</b>											
Total	932434	540899	51.59		481700	0	0	202208	12008	41627	16011
Maximum Day	386798	76904	6.2	238.94	73800	0	0	97300	4003	20814	5604
Minimum Day	5648	9122	1.58	80.02	44700	0	0	6082	267	6404	5070
Average Day	30079	41608	3.97	169.04	68814	0	0	25276	1715	13876	5337
<b>SUMMARY</b>											
	Influent	Treated	Time (hrs)	Rate (liters/min)	Effluent	DP	Misc	Recirc	Sludge Processed	Sludge Added	Decant
Total 2003	12156083	13496722	1096.15		11257314	0	0	3106219	130308	212977	89658
Maximum Month	1278221	2061843			1472800	0	0	626038	15213	41627	17345
Minimum Month	727717	540899			481700	0	0	10696	801	7509	3202
Average Month	1013007	1124727	91.35	205.21	938110	0	0	258852	10859	17748	7472
Issued 01/06/2004 14:39:50											

02395



**Appendix B**

**TA-50 RLWTF Daily Flow Summary for CY 2003**

TA50 DAILY FLOWS(liters) for JAN-2003											
	Influent	Treated	Time (hrs)	Rate (liters/min)	Effluent	DP	Misc	Recirc	Sludge Processed	Sludge Added	Decant
1-Jan-03	12801	0	0	0	0	0	0	0	0	0	0
2-Jan-03	16703	39114	5.87	111.06	72900	0	0	8577	0	0	0
3-Jan-03	40551	47025	3.55	220.77	72900	0	0	0	0	0	0
4-Jan-03	14711	0	0	0	0	0	0	0	0	0	0
5-Jan-03	16392	0	0	0	0	0	0	0	0	0	0
6-Jan-03	41909	100330	6.2	269.7	74300	0	0	0	0	0	0
7-Jan-03	4691	89288	6.25	238.1	149100	0	0	0	0	0	0
8-Jan-03	56050	63489	6.75	156.76	75900	0	0	0	267	0	0
9-Jan-03	19601	63531	1.08	980.42	0	0	0	72782	0	0	0
10-Jan-03	0	79969	6.13	217.43	71700	0	0	0	0	0	4269
11-Jan-03	253717	0	0	0	0	0	0	0	0	7509	0
12-Jan-03	16661	0	0	0	0	0	0	0	0	0	0
13-Jan-03	24275	98762	7.1	231.84	0	0	0	52945	0	0	0
14-Jan-03	27330	41336	3.43	200.86	74300	0	0	0	0	0	0
15-Jan-03	48769	82630	5.62	245.05	76500	0	0	0	0	0	0
16-Jan-03	28349	69307	3.13	369.05	0	0	0	40269	267	0	0
17-Jan-03	14679	35030	4.67	125.02	74860	0	0	0	0	0	0
18-Jan-03	15871	0	0	0	0	0	0	0	0	0	0
19-Jan-03	14671	0	0	0	0	0	0	0	0	0	0
20-Jan-03	16083	0	0	0	0	0	0	0	0	0	0
21-Jan-03	67280	64841	4.18	258.54	73200	0	0	0	0	0	0
22-Jan-03	48236	65058	4.83	224.49	68900	0	0	0	0	0	0
23-Jan-03	67443	81959	6.5	210.15	0	0	0	0	267	0	0
24-Jan-03	20972	36056	3.95	152.14	74800	0	0	0	0	0	0
25-Jan-03	20319	0	0	0	0	0	0	0	0	0	0
26-Jan-03	20897	0	0	0	0	0	0	0	0	0	0
27-Jan-03	47043	41559	3.58	193.48	74600	0	0	0	0	0	0
28-Jan-03	52907	69731	4.8	242.12	0	0	0	0	0	0	4269
29-Jan-03	35644	27994	2.08	224.31	73400	0	0	0	0	0	0
30-Jan-03	42558	73236	5.78	211.18	75100	0	0	0	0	0	0
31-Jan-03	43838	73236	4.52	270.04	0	0	0	0	0	0	0
Total	1150951	1343481	100		1182460	0	0	174573	801	7509	8538
Maximum Day	253717	100330	7.1	980.42	149100	0	0	72782	267	7509	4269
Minimum Day	4691	27994	1.08	111.06	68900	0	0	8577	267	7509	4269
Average Day	37127	63975	4.76	254.88	78831	0	0	43643	267	7509	4269

Issued 01/06/2004 14:39:50

**TA50 DAILY FLOWS(liters) for FEB-2003**

	Influent	Treated	Time (hrs)	Rate (liters/min)	Effluent	DP	Misc	Recirc	Sludge Processed	Sludge Added	Decant
1-Feb-03	16634	0	0	0	0	0	0	0	0	0	0
2-Feb-03	16536	0	0	0	0	0	0	0	0	0	0
3-Feb-03	23024	73236	3.93	310.59	74900	0	0	39394	0	0	0
4-Feb-03	83464	0	0	0	0	0	0	0	0	0	0
5-Feb-03	12674	0	0	0	73700	0	0	22184	0	0	0
6-Feb-03	0	42646	7.38	96.31	0	0	0	0	0	0	0
7-Feb-03	13497	40269	3.22	208.43	74600	0	0	0	0	0	0
8-Feb-03	16120	0	0	0	0	0	0	0	0	0	0
9-Feb-03	16301	0	0	0	0	0	0	0	0	0	0
10-Feb-03	6429	51461	4.15	206.67	0	0	0	27120	0	0	0
11-Feb-03	11580	22682	1.3	290.79	74700	0	0	81436	0	22682	0
12-Feb-03	49737	86381	6.87	209.56	0	0	0	0	0	0	0
13-Feb-03	56744	83863	4.92	284.09	73100	0	0	0	0	0	0
14-Feb-03	13670	50380	4.33	193.92	74100	0	0	0	0	0	0
15-Feb-03	15407	0	0	0	0	0	0	0	0	0	0
16-Feb-03	15360	0	0	0	0	0	0	0	0	0	0
17-Feb-03	15814	0	0	0	0	0	0	0	0	0	0
18-Feb-03	30500	39394	4	164.14	73200	0	0	0	1868	0	0
19-Feb-03	40698	0	0	0	75300	0	0	0	0	0	0
20-Feb-03	32183	31631	2.67	197.45	0	0	0	0	1601	0	0
21-Feb-03	5732	42388	5.32	132.79	0	0	0	5348	2135	0	0
22-Feb-03	17087	0	0	0	0	0	0	0	939	0	0
23-Feb-03	16930	0	0	0	0	0	0	0	0	0	0
24-Feb-03	51326	90023	5.98	250.9	70900	0	0	0	1067	0	0
25-Feb-03	47242	0	0	0	0	0	0	0	1877	0	0
26-Feb-03	54459	70004	5.23	223.08	74400	0	0	0	1067	0	0
27-Feb-03	48569	68614	5.5	207.92	74400	0	0	0	1067	0	0
28-Feb-03	0	7036	3.9	30.07	0	0	0	0	0	0	0
<b>Total</b>	<b>727717</b>	<b>800008</b>	<b>68.7</b>		<b>813300</b>	<b>0</b>	<b>0</b>	<b>175482</b>	<b>11621</b>	<b>22682</b>	<b>0</b>
Maximum Day	83464	90023	7.38	310.59	75300	0	0	81436	2135	22682	0
Minimum Day	5732	7036	1.3	30.07	70900	0	0	5348	939	22682	0
Average Day	25990	53334	4.58	200.45	73936	0	0	35096	1453	22682	0
Issued 01/06/2004 14:39:50											

02104

TA50 DAILY FLOWS(liters) for MAR-2003											
	Influent	Treated	Time (hrs)	Rate (liters/min)	Effluent	DP	Misc	Recirc	Sludge Processed	Sludge Added	Decant
1-Mar-03	19162	0	0	0	0	0	0	0	0	0	0
2-Mar-03	20305	0	0	0	0	0	0	0	469	0	0
3-Mar-03	35094	51525	4.75	180.79	74600	0	0	6239	801	0	0
4-Mar-03	46095	73690	4.7	261.31	73500	0	0	8913	801	0	0
5-Mar-03	27681	0	0	0	74500	0	0	8913	0	11741	0
6-Mar-03	31911	73796	6.37	193.08	0	0	0	0	0	0	0
7-Mar-03	26215	0	0	0	0	0	0	0	0	0	0
8-Mar-03	21166	0	0	0	0	0	0	0	0	0	0
9-Mar-03	20614	0	0	0	0	0	0	0	0	0	0
10-Mar-03	28411	45113	4.5	167.09	74100	0	0	0	0	0	0
11-Mar-03	46151	57351	4.83	197.9	0	0	0	0	0	0	0
12-Mar-03	37314	47628	3.57	222.35	74700	0	0	0	0	0	0
13-Mar-03	57431	0	0	0	0	0	0	19387	0	0	0
14-Mar-03	29835	0	0	0	0	0	0	0	0	0	0
15-Mar-03	25388	0	0	0	0	0	0	0	0	0	0
16-Mar-03	26504	0	0	0	0	0	0	0	0	0	0
17-Mar-03	11849	61431	7.57	135.25	72500	0	0	4456	801	0	0
18-Mar-03	44394	85098	6	236.38	74800	0	0	0	0	0	5070
19-Mar-03	40917	66359	5.83	189.71	74000	0	0	0	2668	0	0
20-Mar-03	27944	69935	4.22	276.2	0	0	0	22789	534	0	0
21-Mar-03	57573	100472	4.93	339.66	74800	0	0	36771	267	0	0
22-Mar-03	17804	0	0	0	0	0	0	0	0	0	0
23-Mar-03	19794	0	0	0	0	0	0	0	267	0	0
24-Mar-03	19497	39720	4.63	142.98	74700	0	0	24065	801	0	0
25-Mar-03	0	0	0	0	76100	0	0	535	534	0	0
26-Mar-03	30409	0	0	0	0	0	0	43732	534	0	0
27-Mar-03	41888	101265	5.58	302.46	73700	0	0	29504	534	0	0
28-Mar-03	52339	42116	2.5	280.77	0	0	0	0	267	0	0
29-Mar-03	17226	0	0	0	0	0	0	0	0	0	0
30-Mar-03	18100	0	0	0	0	0	0	0	267	0	0
31-Mar-03	4037	56786	6.82	138.77	73000	0	0	6239	0	0	0
Total	903048	972285	76.8		965000	0	0	211543	9545	11741	5070
Maximum Day	57573	101265	7.57	339.66	76100	0	0	43732	2668	11741	5070
Minimum Day	4037	39720	2.5	135.25	72500	0	0	535	267	11741	5070
Average Day	29131	64819	5.12	217.65	74231	0	0	17629	682	11741	5070

Issued 01/06/2004 14:39:50

TA50 DAILY FLOWS(liters) for APR-2003											
	Influent	Treated	Time (hrs)	Rate (liters/min)	Effluent	DP	Misc	Recirc	Sludge Processed	Sludge Added	Decant
1-Apr-03	63687	38671	2.92	220.72	74600	0	0	0	0	0	14409
2-Apr-03	32774	65337	5.42	200.91	0	0	0	0	0	0	0
3-Apr-03	57602	0	0	0	0	0	0	35015	1334	0	0
4-Apr-03	21167	48841	4.68	173.94	74800	0	0	0	0	0	0
5-Apr-03	21448	0	0	0	0	0	0	0	267	0	0
6-Apr-03	22887	0	0	0	0	0	0	0	0	0	0
7-Apr-03	45721	57140	1.83	520.4	0	0	0	30594	0	0	0
8-Apr-03	50273	86328	5.67	253.76	72100	0	0	0	1334	0	0
9-Apr-03	61807	26797	0.58	770.03	63300	0	0	0	0	15210	0
10-Apr-03	33390	90723	6.92	218.5	0	0	0	10696	534	0	0
11-Apr-03	0	63616	5.67	187	72400	0	0	0	267	0	0
12-Apr-03	21744	0	0	0	0	0	0	0	0	0	0
13-Apr-03	22322	0	0	0	0	0	0	0	0	0	0
14-Apr-03	75117	97899	5.22	312.58	75800	0	0	0	1334	0	0
15-Apr-03	31589	84466	7	201.11	148800	0	0	0	2135	0	0
16-Apr-03	27692	89580	6.7	222.84	74500	0	0	23174	0	0	0
17-Apr-03	41787	75683	6.03	209.18	75700	0	0	5348	1334	0	0
18-Apr-03	53904	58011	3.12	309.89	74100	0	0	0	0	0	0
19-Apr-03	21098	0	0	0	0	0	0	0	0	0	0
20-Apr-03	22097	0	0	0	0	0	0	0	0	0	0
21-Apr-03	2808	32548	2.08	260.8	0	0	0	61355	1067	0	0
22-Apr-03	69838	43866	2.42	302.11	0	0	0	11881	267	0	0
23-Apr-03	37859	0	0	0	0	0	0	19489	0	0	0
24-Apr-03	33827	84459	4.33	325.09	0	0	0	39099	267	0	0
25-Apr-03	48600	46684	3.67	212.01	0	0	0	0	0	0	0
26-Apr-03	20897	0	0	0	0	0	0	0	0	0	0
27-Apr-03	21730	0	0	0	0	0	0	0	0	0	0
28-Apr-03	27852	43323	5.17	139.66	75400	0	0	0	0	0	0
29-Apr-03	32345	85250	7.23	196.52	73800	0	0	0	0	0	0
30-Apr-03	24966	0	0	0	69800	0	0	0	0	0	0
<b>Total</b>	<b>1048828</b>	<b>1219222</b>	<b>86.66</b>		<b>1025100</b>	<b>0</b>	<b>0</b>	<b>236651</b>	<b>10140</b>	<b>15210</b>	<b>14409</b>
Maximum Day	75117	97899	7.23	770.03	148800	0	0	61355	2135	15210	14409
Minimum Day	2808	26797	0.58	139.66	63300	0	0	5348	267	15210	14409
Average Day	34961	64170	4.56	275.63	78854	0	0	26295	922	15210	14409

Issued 01/06/2004 14:39:50

021103

TA50 DAILY FLOWS(liters) for MAY-2003											
	Influent	Treated	Time (hrs)	Rate (liters/min)	Effluent	DP	Misc	Recirc	Sludge Processed	Sludge Added	Decant
1-May-03	41515	73236	7.92	154.12	0	0	0	0	0	0	0
2-May-03	32841	0	0	0	0	0	0	55261	1067	0	0
3-May-03	19105	0	0	0	0	0	0	0	267	0	0
4-May-03	21235	0	0	0	0	0	0	0	0	0	0
5-May-03	38724	69873	5.68	205.03	72000	0	0	0	267	0	0
6-May-03	39974	39394	4.08	160.92	72000	0	0	0	2135	0	0
7-May-03	74783	88811	7.5	197.36	73600	0	0	0	1601	0	0
8-May-03	35403	57661	6.02	159.64	75400	0	0	0	1868	0	0
9-May-03	30436	54693	4.75	191.91	0	0	0	0	0	0	0
10-May-03	14617	0	0	0	0	0	0	0	0	0	0
11-May-03	14644	0	0	0	0	0	0	0	0	0	0
12-May-03	54390	43022	4.03	177.92	74300	0	0	0	0	0	0
13-May-03	29881	49886	6.92	120.15	74800	0	0	27630	1334	0	0
14-May-03	44400	31319	3.42	152.63	73800	0	0	0	0	0	0
15-May-03	48009	65696	5.45	200.91	0	0	0	0	1334	0	0
16-May-03	41029	52131	5.67	153.24	74800	0	0	0	0	0	0
17-May-03	15146	0	0	0	0	0	0	0	267	0	0
18-May-03	18934	0	0	0	0	0	0	0	0	0	0
19-May-03	57483	86580	7.18	200.97	0	0	0	0	0	15210	0
20-May-03	37222	80240	6.93	192.98	72800	0	0	31536	0	0	0
21-May-03	33800	89799	8.52	175.66	145600	0	0	0	0	0	0
22-May-03	48040	44597	6.28	118.36	0	0	0	9804	267	0	0
23-May-03	62386	37600	3.25	192.82	74900	0	0	0	0	0	0
24-May-03	17777	0	0	0	0	0	0	0	0	0	0
25-May-03	14600	0	0	0	0	0	0	0	0	0	0
26-May-03	14967	0	0	0	0	0	0	0	0	0	0
27-May-03	116010	33936	2.73	207.18	0	0	0	0	0	0	0
28-May-03	116849	72418	7.05	171.2	74000	0	0	0	267	0	0
29-May-03	40310	60153	1.83	547.84	0	0	0	67846	1601	0	0
30-May-03	65015	80366	5.23	256.11	0	0	0	17868	1067	0	0
31-May-03	19485	0	0	0	0	0	0	0	0	0	0
Total	1259010	1211411	110.44		958000	0	0	209945	13342	15210	0
Maximum Day	116849	89799	8.52	547.84	145600	0	0	67846	2135	15210	0
Minimum Day	14600	31319	1.83	118.36	72000	0	0	9804	267	15210	0
Average Day	40613	60571	5.52	196.85	79833	0	0	34991	1026	15210	0

Issued 01/06/2004 14:39:50

**TA50 DAILY FLOWS(liters) for JUN-2003**

	Influent	Treated	Time (hrs)	Rate (liters/min)	Effluent	DP	Misc	Recirc	Sludge Processed	Sludge Added	Decant
1-Jun-03	44864	0	0	0	0	0	0	0	0	0	0
2-Jun-03	64010	150014	1.92	1302.2	0	0	0	145181	801	0	0
3-Jun-03	0	112847	7.5	250.77	72700	0	0	38772	267	0	0
4-Jun-03	73821	101403	5.67	298.07	73800	0	0	26739	801	0	0
5-Jun-03	27266	105950	8.25	214.04	149000	0	0	20500	0	0	0
6-Jun-03	82966	103782	5.42	319.13	74800	0	0	0	0	0	0
7-Jun-03	3217	96410	0.5	3213.67	74800	0	0	101608	0	0	0
8-Jun-03	37470	0	0	0	0	0	0	5348	0	0	0
9-Jun-03	7782	98715	9.43	174.47	74400	0	0	40108	1868	0	0
10-Jun-03	22689	84765	7.13	198.14	74000	0	0	0	1067	0	0
11-Jun-03	68908	108435	8	225.91	74600	0	0	0	1067	0	0
12-Jun-03	121426	90512	6.5	232.08	74800	0	0	0	1067	0	0
13-Jun-03	41809	69806	5	232.69	75900	0	0	7130	0	0	0
14-Jun-03	20614	0	0	0	0	0	0	0	0	0	0
15-Jun-03	22833	0	0	0	0	0	0	0	0	0	0
16-Jun-03	37820	42502	4.83	146.66	74800	0	0	0	0	0	0
17-Jun-03	56080	94794	5.33	296.42	0	0	0	0	1067	0	0
18-Jun-03	45200	82261	3.83	357.97	75100	0	0	25848	0	10941	0
19-Jun-03	69087	107021	6.5	274.41	71600	0	0	34761	1334	0	0
20-Jun-03	71033	123959	8.5	243.06	146000	0	0	25848	0	0	0
21-Jun-03	16587	85449	7.5	189.89	0	0	0	39217	267	0	0
22-Jun-03	36701	0	0	0	0	0	0	0	0	0	0
23-Jun-03	7716	58233	6.33	153.33	73700	0	0	57934	2668	0	0
24-Jun-03	43728	61616	7.47	137.47	66100	0	0	0	1334	0	0
25-Jun-03	19730	52281	8	108.92	71400	0	0	0	0	0	3202
26-Jun-03	72325	79945	4.58	290.92	0	0	0	0	0	2935	0
27-Jun-03	42489	78278	4.37	298.54	0	0	0	37435	0	7205	0
28-Jun-03	0	0	0	0	0	0	0	0	0	0	0
29-Jun-03	49038	0	0	0	0	0	0	0	0	0	0
30-Jun-03	71012	72865	6.92	175.49	75300	0	0	19609	0	0	4803
<b>Total</b>	<b>1278221</b>	<b>2061843</b>	<b>139.48</b>		<b>1472800</b>	<b>0</b>	<b>0</b>	<b>626038</b>	<b>13608</b>	<b>21081</b>	<b>8005</b>
Maximum Day	121426	150014	9.43	3213.67	149000	0	0	145181	2668	10941	4803
Minimum Day	3217	42502	0.5	108.92	66100	0	0	5348	267	2935	3202
Average Day	42607	89645	6.06	405.84	81822	0	0	41736	1134	7027	4002
Issued 01/06/2004 14:39:50											

02105

TA50 DAILY FLOWS(liters) for JUL-2003											
	Influent	Treated	Time (hrs)	Rate (liters/min)	Effluent	DP	Misc	Recirc	Sludge Processed	Sludge Added	Decant
1-Jul-03	21867	92646	7.25	212.98	76800	0	0	22282	801	0	0
2-Jul-03	76814	115809	5.33	362.13	75600	0	0	16935	0	4536	0
3-Jul-03	26317	64459	6.5	165.28	75600	0	0	12478	2135	0	0
4-Jul-03	16903	0	0	0	0	0	0	0	0	0	0
5-Jul-03	19727	0	0	0	0	0	0	0	0	0	0
6-Jul-03	17185	0	0	0	0	0	0	0	267	0	0
7-Jul-03	55729	88849	6.33	233.94	76200	0	0	16043	0	1067	0
8-Jul-03	43899	74223	6.67	185.46	74400	0	0	0	0	0	0
9-Jul-03	66062	40776	3.58	189.83	76200	0	0	0	0	0	0
10-Jul-03	49833	39732	2.5	264.88	0	0	0	50293	0	0	5337
11-Jul-03	17061	66555	1.25	887.4	0	0	0	62786	267	0	0
12-Jul-03	16338	0	0	0	0	0	0	0	0	0	0
13-Jul-03	18907	0	0	0	0	0	0	0	0	0	0
14-Jul-03	90855	75541	7	179.86	75200	0	0	0	0	0	4003
15-Jul-03	30384	78936	6.43	204.6	76400	0	0	0	0	8005	0
16-Jul-03	23524	32967	4.98	110.33	0	0	0	17826	801	0	0
17-Jul-03	24536	50551	6.5	129.62	76000	0	0	0	0	0	0
18-Jul-03	7652	24434	4.33	94.05	0	0	0	0	267	0	0
19-Jul-03	18157	0	0	0	0	0	0	0	0	0	0
20-Jul-03	18782	0	0	0	0	0	0	0	0	0	0
21-Jul-03	45405	37914	5.23	120.82	77400	0	0	0	0	0	8005
22-Jul-03	13299	73505	5.08	241.16	0	0	0	48593	0	0	0
23-Jul-03	37737	52615	4.82	181.93	75500	0	0	0	1334	0	0
24-Jul-03	40441	64875	7.25	149.14	77200	0	0	0	1601	0	0
25-Jul-03	27459	50999	5.75	147.82	0	0	0	0	1067	0	0
26-Jul-03	15702	0	0	0	0	0	0	0	267	0	0
27-Jul-03	22743	0	0	0	0	0	0	0	0	0	0
28-Jul-03	38867	51832	5.83	148.18	76100	0	0	0	0	0	0
29-Jul-03	39330	60227	5.58	179.89	77400	0	0	0	1334	0	0
30-Jul-03	23525	62650	6.67	156.55	76400	0	0	0	801	0	0
31-Jul-03	82727	50238	3.17	264.13	76400	0	0	18717	1334	0	0
Total	1047767	1350333	118.03		1218800	0	0	265953	12276	13608	17345
Maximum Day	90855	115809	7.25	887.4	77400	0	0	62786	2135	8005	8005
Minimum Day	7652	24434	1.25	94.05	74400	0	0	12478	267	1067	4003
Average Day	33799	61379	5.36	218.64	76175	0	0	29550	944	4536	5782

Issued 01/06/2004 14:39:50



TA50 DAILY FLOWS(liters) for AUG-2003											
	Influent	Treated	Time (hrs)	Rate (liters/min)	Effluent	DP	Misc	Recirc	Sludge Processed	Sludge Added	Decant
1-Aug-03	0	14884	5.42	45.77	0	0	0	0	534	0	0
2-Aug-03	16181	0	0	0	0	0	0	0	0	0	0
3-Aug-03	17464	0	0	0	0	0	0	0	267	0	0
4-Aug-03	9806	62373	7.83	132.77	77000	0	0	1783	0	6938	0
5-Aug-03	25184	43796	3.55	205.62	0	0	0	0	0	13876	0
6-Aug-03	29465	0	0	0	0	0	0	0	0	0	0
7-Aug-03	31366	39315	4.33	151.33	0	0	0	0	267	0	0
8-Aug-03	105042	0	0	0	0	0	0	0	0	0	0
9-Aug-03	79536	0	0	0	0	0	0	0	267	0	0
10-Aug-03	44904	0	0	0	0	0	0	0	0	0	0
11-Aug-03	43607	0	0	0	72630	0	0	0	1601	0	0
12-Aug-03	17464	83620	9.97	139.79	72630	0	0	0	2668	0	0
13-Aug-03	20044	61444	7.33	139.71	72630	0	0	0	1334	0	0
14-Aug-03	55472	73058	6.08	200.27	73236	0	0	0	1601	0	0
15-Aug-03	19604	40070	3.92	170.37	0	0	0	0	0	0	0
16-Aug-03	16889	0	0	0	0	0	0	0	0	0	0
17-Aug-03	17495	0	0	0	0	0	0	0	267	0	0
18-Aug-03	33238	0	0	0	73236	0	0	0	0	0	0
19-Aug-03	31500	45250	5.58	135.16	0	0	0	0	0	0	3202
20-Aug-03	50028	61124	5.42	187.96	72630	0	0	0	1067	0	0
21-Aug-03	30270	49353	5.42	151.76	72630	0	0	0	1067	0	0
22-Aug-03	31334	39833	3.42	194.12	0	0	0	0	1067	0	0
23-Aug-03	19589	0	0	0	0	0	0	0	0	0	0
24-Aug-03	17545	0	0	0	0	0	0	0	267	0	0
25-Aug-03	33695	55337	4.15	222.24	72630	0	0	0	0	0	0
26-Aug-03	17102	70053	6.8	171.7	73236	0	0	0	801	0	0
27-Aug-03	38021	98211	7.67	213.41	73236	0	0	0	0	15210	0
28-Aug-03	59345	80117	8.13	164.24	72630	0	0	8913	267	0	0
29-Aug-03	32587	38085	5.6	113.35	0	0	0	0	0	0	0
30-Aug-03	16685	0	0	0	0	0	0	0	267	0	0
31-Aug-03	33530	0	0	0	0	0	0	0	0	0	0
Total	993992	955923	100.62		878354	0	0	10696	13609	36024	3202
Maximum Day	105042	98211	9.97	222.24	77000	0	0	8913	2668	15210	3202
Minimum Day	9806	14884	3.42	45.77	72630	0	0	1783	267	6938	3202
Average Day	32064	56231	5.92	161.15	73196	0	0	5348	851	12008	3202

Issued 01/06/2004 14:39:50

TA50 DAILY FLOWS(liters) for SEP-2003											
	Influent	Treated	Time (hrs)	Rate (liters/min)	Effluent	DP	Misc	Recirc	Sludge Processed	Sludge Added	Decant
1-Sep-03	111	0	0	0	0	0	0	0	0	0	0
2-Sep-03	0	3425	4.33	13.18	74000	0	0	0	0	0	5871
3-Sep-03	37345	54633	4	227.64	74000	0	0	12478	2135	0	0
4-Sep-03	29546	68270	6	189.64	74000	0	0	0	2135	0	0
5-Sep-03	41073	55602	4.28	216.52	0	0	0	0	1067	0	0
6-Sep-03	14630	0	0	0	0	0	0	0	0	0	0
7-Sep-03	9537	0	0	0	0	0	0	0	267	0	0
8-Sep-03	68013	28384	3	157.69	74000	0	0	14261	801	0	0
9-Sep-03	32354	57661	5.42	177.31	0	0	0	0	534	0	0
10-Sep-03	39291	32967	2.75	199.8	74000	0	0	0	1067	0	0
11-Sep-03	20414	58168	4.33	223.9	74000	0	0	32532	0	0	0
12-Sep-03	22579	0	0	0	0	0	0	0	267	0	0
13-Sep-03	18200	0	0	0	0	0	0	0	0	0	0
14-Sep-03	16984	0	0	0	0	0	0	0	0	0	0
15-Sep-03	53470	55185	6.17	149.07	74000	0	0	0	0	0	0
16-Sep-03	81974	68232	4.95	229.74	0	0	0	0	0	0	0
17-Sep-03	31696	31487	4.25	123.48	74000	0	0	14261	1868	0	0
18-Sep-03	44468	47161	3.8	206.85	74000	0	0	0	2402	0	0
19-Sep-03	18940	59754	6.12	162.73	0	0	0	0	801	0	0
20-Sep-03	13255	0	0	0	0	0	0	0	0	0	0
21-Sep-03	12112	0	0	0	0	0	0	0	267	0	0
22-Sep-03	33427	35587	2.97	199.7	74000	0	0	0	0	0	0
23-Sep-03	51863	36052	3.92	153.28	74000	0	0	0	801	0	0
24-Sep-03	20851	27824	3.08	150.56	0	0	0	0	534	0	0
25-Sep-03	32915	0	0	0	0	0	0	0	0	0	0
26-Sep-03	41720	0	0	0	0	0	0	0	0	0	0
27-Sep-03	15210	0	0	0	0	0	0	0	0	0	0
28-Sep-03	14967	0	0	0	0	0	0	0	0	0	0
29-Sep-03	26961	26919	3.05	147.1	74000	0	0	0	267	0	0
30-Sep-03	27301	60144	5.25	190.93	0	0	0	0	0	0	0
<b>Total</b>	<b>871207</b>	<b>807455</b>	<b>77.67</b>		<b>888000</b>	<b>0</b>	<b>0</b>	<b>73532</b>	<b>15213</b>	<b>0</b>	<b>5871</b>
Maximum Day	81974	68270	6.17	229.74	74000	0	0	32532	2402	0	5871
Minimum Day	111	3425	2.75	13.18	74000	0	0	12478	267	0	5871
Average Day	29040	44859	4.31	173.28	74000	0	0	18383	1014	0	5871

Issued 01/06/2004 14:39:50

**TA50 DAILY FLOWS(liters) for OCT-2003**

	Influent	Treated	Time (hrs)	Rate (liters/min)	Effluent	DP	Misc	Recirc	Sludge Processed	Sludge Added	Decant
1-Oct-03	67926	43361	2.37	304.93	0	0	0	0	0	0	0
2-Oct-03	30340	104220	4.75	365.68	0	0	0	72006	0	0	0
3-Oct-03	42177	37646	3.92	160.06	0	0	0	0	0	0	0
4-Oct-03	20981	0	0	0	0	0	0	0	267	0	0
5-Oct-03	18944	0	0	0	0	0	0	0	0	0	0
6-Oct-03	82100	25641	2	213.68	0	0	0	73236	0	0	0
7-Oct-03	57274	111513	3.88	479.01	0	0	0	64075	0	0	0
8-Oct-03	31653	0	0	0	0	0	0	29139	0	14409	0
9-Oct-03	0	25388	2	211.57	0	0	0	43928	0	6671	0
10-Oct-03	0	57298	4.33	220.55	0	0	0	58808	0	0	0
11-Oct-03	0	0	0	0	0	0	0	45898	0	0	0
12-Oct-03	29268	0	0	0	0	0	0	0	0	0	0
13-Oct-03	0	0	0	0	0	0	0	24489	0	0	0
14-Oct-03	9608	1293	1	21.55	0	0	0	0	0	0	0
15-Oct-03	0	31231	4.83	107.77	71300	0	0	0	0	0	0
16-Oct-03	0	60176	5.67	176.88	0	0	0	39217	801	0	0
17-Oct-03	4902	25356	7.37	57.34	0	0	0	0	1067	0	0
18-Oct-03	14684	0	0	0	0	0	0	0	0	0	0
19-Oct-03	9022	0	0	0	0	0	0	0	0	0	0
20-Oct-03	42161	53242	5.63	157.61	71500	0	0	0	801	0	0
21-Oct-03	131121	89048	5.67	261.75	71900	0	0	11587	1067	0	0
22-Oct-03	9578	69980	4.57	255.22	0	0	0	20500	801	0	0
23-Oct-03	68482	79847	5.52	241.08	69200	0	0	12478	1067	0	0
24-Oct-03	1011	38100	2.75	230.91	73300	0	0	10874	267	0	0
25-Oct-03	0	0	0	0	0	0	0	0	0	0	0
26-Oct-03	18155	0	0	0	0	0	0	0	0	0	0
27-Oct-03	46578	90002	4.22	355.46	71400	0	0	18717	1601	0	0
28-Oct-03	15689	54693	4.97	183.41	73800	0	0	14261	1067	0	0
29-Oct-03	33267	78256	5.55	235	0	0	0	14261	0	7205	0
30-Oct-03	51719	84615	7.08	199.19	72200	0	0	22282	0	0	0
31-Oct-03	7441	74889	4.32	288.92	73600	0	0	24956	0	0	0
Total	844081	1235795	92.4		648200	0	0	600712	8806	28285	0
Maximum Day	131121	111513	7.37	479.01	73800	0	0	73236	1601	14409	0
Minimum Day	1011	1293	1	21.55	69200	0	0	10874	267	6671	0
Average Day	27228	58847	4.4	225.12	72022	0	0	33373	881	9428	0

Issued 01/06/2004 14:39:50

021109

TA50 DAILY FLOWS(liters) for NOV-2003											
	Influent	Treated	Time (hrs)	Rate (liters/min)	Effluent	DP	Misc	Recirc	Sludge Processed	Sludge Added	Decant
1-Nov-03	7805	0	0	0	0	0	0	0	0	0	0
2-Nov-03	22208	0	0	0	0	0	0	0	0	0	0
3-Nov-03	54321	81986	5.22	261.77	71500	0	0	0	0	0	0
4-Nov-03	51166	93136	8.25	188.15	73900	0	0	11587	0	0	0
5-Nov-03	26665	86552	8.67	166.38	72600	0	0	23174	0	0	0
6-Nov-03	53772	56868	2.33	406.78	74200	0	0	8022	0	0	0
7-Nov-03	39543	97281	2.58	628.43	0	0	0	60608	0	0	0
8-Nov-03	27519	0	0	0	0	0	0	0	0	0	0
9-Nov-03	12217	0	0	0	0	0	0	0	0	0	0
10-Nov-03	3433	55851	6.33	147.05	72800	0	0	0	0	0	0
11-Nov-03	12745	0	0	0	0	0	0	0	0	0	0
12-Nov-03	23378	0	0	0	0	0	0	91073	0	0	0
13-Nov-03	64547	100594	4.92	340.77	144200	0	0	19609	0	0	11207
14-Nov-03	59800	108947	3.78	480.37	0	0	0	40942	1334	0	0
15-Nov-03	22481	0	0	0	0	0	0	0	0	0	0
16-Nov-03	33428	0	0	0	0	0	0	0	0	0	0
17-Nov-03	16882	34503	3.55	161.99	73300	0	0	0	1868	0	0
18-Nov-03	28478	72759	5.75	210.9	71900	0	0	0	0	0	0
19-Nov-03	30684	50549	4.08	206.49	0	0	0	0	1601	0	0
20-Nov-03	10436	18542	3.37	91.7	71200	0	0	59590	801	0	0
21-Nov-03	26217	0	0	0	0	0	0	4281	1067	0	0
22-Nov-03	144790	0	0	0	0	0	0	0	267	0	0
23-Nov-03	258843	0	0	0	0	0	0	0	0	0	0
24-Nov-03	0	86752	7.43	194.6	0	0	0	0	1067	0	0
25-Nov-03	9238	53747	7.5	119.44	0	0	0	0	1334	0	0
26-Nov-03	29767	0	0	0	0	0	0	0	0	0	0
27-Nov-03	9181	0	0	0	0	0	0	0	0	0	0
28-Nov-03	2975	0	0	0	0	0	0	0	0	0	0
29-Nov-03	7749	0	0	0	0	0	0	0	0	0	0
30-Nov-03	8559	0	0	0	0	0	0	0	0	0	0
<b>Total</b>	<b>1098827</b>	<b>998067</b>	<b>73.76</b>		<b>725600</b>	<b>0</b>	<b>0</b>	<b>318886</b>	<b>9339</b>	<b>0</b>	<b>11207</b>
Maximum Day	258843	108947	8.67	628.43	144200	0	0	91073	1868	0	11207
Minimum Day	2975	18542	2.33	91.7	71200	0	0	4281	267	0	11207
Average Day	36628	71290	5.27	257.49	80622	0	0	35432	1167	0	11207
Issued 01/06/2004 14:39:50											

**TA50 DAILY FLOWS(liters) for DEC-2003**

	Influent	Treated	Time (hrs)	Rate (liters/min)	Effluent	DP	Misc	Recirc	Sludge Processed	Sludge Added	Decant
1-Dec-03	23217	74837	5.22	238.94	72900	0	0	0	0	14409	0
2-Dec-03	21493	22967	2.08	184.03	72900	0	0	6082	0	6404	0
3-Dec-03	37999	76904	5.77	222.14	0	0	0	0	0	0	0
4-Dec-03	29434	9122	1.9	80.02	73800	0	0	24492	0	0	0
5-Dec-03	0	30931	4.3	119.89	0	0	0	0	2668	0	0
6-Dec-03	6213	0	0	0	0	0	0	0	0	0	0
7-Dec-03	10180	0	0	0	0	0	0	0	0	0	0
8-Dec-03	18426	44591	4.37	170.06	0	0	0	0	0	0	5070
9-Dec-03	29320	0	0	0	73000	0	0	12203	0	0	5604
10-Dec-03	53654	0	0	0	0	0	0	0	1334	0	0
11-Dec-03	18054	75692	6.2	203.47	0	0	0	13370	267	0	0
12-Dec-03	24966	40859	3.42	199.12	73000	0	0	14001	0	0	0
13-Dec-03	5648	0	0	0	0	0	0	0	0	0	0
14-Dec-03	5685	0	0	0	0	0	0	0	0	0	0
15-Dec-03	94008	45772	3.88	196.62	0	0	0	0	0	0	5337
16-Dec-03	0	0	0	0	0	0	0	97300	1334	0	0
17-Dec-03	0	14001	2.62	89.06	71400	0	0	18717	0	0	0
18-Dec-03	15166	20814	1.58	219.56	0	0	0	0	0	20814	0
19-Dec-03	22791	0	0	0	44700	0	0	0	0	0	0
20-Dec-03	5648	0	0	0	0	0	0	0	0	0	0
21-Dec-03	5648	0	0	0	0	0	0	0	0	0	0
22-Dec-03	14443	41737	5	139.12	0	0	0	16043	2135	0	0
23-Dec-03	10032	42672	5.25	135.47	0	0	0	0	4003	0	0
24-Dec-03	22109	0	0	0	0	0	0	0	0	0	0
25-Dec-03	11296	0	0	0	0	0	0	0	0	0	0
26-Dec-03	28141	0	0	0	0	0	0	0	0	0	0
27-Dec-03	0	0	0	0	0	0	0	0	267	0	0
28-Dec-03	12187	0	0	0	0	0	0	0	0	0	0
29-Dec-03	386798	0	0	0	0	0	0	0	0	0	0
30-Dec-03	0	0	0	0	0	0	0	0	0	0	0
31-Dec-03	19878	0	0	0	0	0	0	0	0	0	0
<b>Total</b>	<b>932434</b>	<b>540899</b>	<b>51.59</b>		<b>481700</b>	<b>0</b>	<b>0</b>	<b>202208</b>	<b>12008</b>	<b>41627</b>	<b>16011</b>
<b>Maximum Day</b>	<b>386798</b>	<b>76904</b>	<b>6.2</b>	<b>238.94</b>	<b>73800</b>	<b>0</b>	<b>0</b>	<b>97300</b>	<b>4003</b>	<b>20814</b>	<b>5604</b>
<b>Minimum Day</b>	<b>5648</b>	<b>9122</b>	<b>1.58</b>	<b>80.02</b>	<b>44700</b>	<b>0</b>	<b>0</b>	<b>6082</b>	<b>267</b>	<b>6404</b>	<b>5070</b>
<b>Average Day</b>	<b>30079</b>	<b>41608</b>	<b>3.97</b>	<b>169.04</b>	<b>68814</b>	<b>0</b>	<b>0</b>	<b>25276</b>	<b>1715</b>	<b>13876</b>	<b>5337</b>

Issued 01/08/2004 11:25:38

**Appendix C**

**TA-50 RLWTF Monthly Radioisotope Summary for CY 2003**

TA50 RADIOISOTOPES				
Summary for JAN-2003				
	RAW nCi/L	RAW Total (Ci)	FINAL pCi/L	FINAL Total (Ci)
ALPHA	35. E0	40.3 E-3	21. E0	24.8 E-6
Am-241	17. E0	19.6 E-3	4.6 E0	5.4 E-6
As-74	*		34. E0	40.2 E-6
BETA	3.3 E0	3.8 E-3	81. E0	95.8 E-6
Be-7	*		*	
Ce-141	*		*	
Co-56	*		*	
Co-57	*		*	
Co-58	*		*	
Co-60	*		*	
Cs-134	*		*	
Cs-137	180. E-3	207.2 E-6	49. E0	57.9 E-6
Eu-152	*		*	
I-133	*		*	
Mn-52	*		*	
Mn-54	*		*	
Na-22	*		*	
Np-237	*		*	
Pu-238	13. E0	15. E-3	6.8 E0	8. E-6
Pu-239	8.1 E0	9.3 E-3	4.1 E0	4.8 E-6
Ra-226	*		8.9 E0	10.5 E-6
Ra-228	*		*	
Rb-83	*		*	
Rb-84	*		*	
Sc-46	*		*	
Sc-48	*		*	
Se-75	*		*	
Sn-113	*		*	
Sr-85	*		*	
Sr-89	*		*	
Sr-90	*		*	
TRITIUM			3.6 E3	4.3 E-3
Th-232	40. E-6	46. E-9	*	
U-234	47.9 E-3	55.1 E-6	*	
U-235	1.8 E-3	2.1 E-6	*	
U-238	25.3 E-3	29.1 E-6	140. E-3	165.5 E-9
V-48	*		*	
Y-88	*		*	
Zn-65	*		*	
Total Alpha		43.9 E-3		29. E-6

Volume of Flow: Influent = 1150951 liters Final = 1182460 liters

\* Less than Detection Limit.

Issued 01/09/2004 10:36:24

<b>TA50 RADIOISOTOPES</b>				
Summary for FEB-2003				
	RAW nCi/L	RAW Total (Ci)	FINAL pCi/L	FINAL Total (Ci)
ALPHA	35. E0	25.5 E-3	9.4 E0	7.6 E-6
Am-241	17. E0	12.4 E-3	2.9 E0	2.4 E-6
As-74	*		22. E0	17.9 E-6
BETA	9.8 E0	7.1 E-3	270. E0	219.6 E-6
Ba-133	670. E-3	487.6 E-6		
Be-7	*		*	
Ce-141	*		*	
Co-56	*		*	
Co-57	*		*	
Co-58	*		*	
Co-60	*		*	
Cs-134	*		*	
Cs-137	4.1 E-3	3. E-6	280. E0	227.7 E-6
Eu-152	*		*	
I-133	*		*	
Mn-52	*		*	
Mn-54	*		*	
Na-22	49. E-3	35.7 E-6	5.8 E0	4.7 E-6
Np-237	*		*	
Pu-238	16. E0	11.6 E-3	5.6 E0	4.6 E-6
Pu-239	7.7 E0	5.6 E-3	3.6 E0	2.9 E-6
Ra-226	*		*	
Ra-228	*		*	
Rb-83	*		*	
Rb-84	*		*	
Sc-46	*		*	
Sc-48	*		*	
Se-75	*		*	
Sn-113	*		*	
Sr-85	250. E-3	181.9 E-6	*	
Sr-89	*		*	
Sr-90	110. E-3	80. E-6	*	
TRITIUM			17. E3	13.8 E-3
Th-232	330. E-6	240.1 E-9	*	
U-234	28. E-3	20.4 E-6	*	
U-235	1. E-3	742.3 E-9	*	
U-238	18.6 E-3	13.5 E-6	*	
V-48	*		*	
Y-88	*		*	
Zn-65	*		*	
Total Alpha		29.7 E-3		9.8 E-6
Volume of Flow: Influent = 727717 liters Final = 813300 liters				
* Less than Detection Limit.				
Issued 01/09/2004 10:36:24				



<b>TA50 RADIOISOTOPES</b>				
Summary for MAR-2003				
	RAW nCi/L	RAW Total (Ci)	FINAL pCi/L	FINAL Total (Ci)
ALPHA	87. E0	78.6 E-3	20. E0	19.3 E-6
Am-241	41. E0	37. E-3	8.2 E0	7.9 E-6
As-74	*		24. E0	23.2 E-6
BETA	6.5 E0	5.9 E-3	420. E0	405.3 E-6
Ba-133	83. E-3	75. E-6		
Be-7	*		*	
Ce-141	*		*	
Co-56	*		*	
Co-57	*		*	
Co-58	*		*	
Co-60	*		*	
Cs-134	*		*	
Cs-137	380. E-3	343.2 E-6	290. E0	279.9 E-6
Eu-152	*		*	
I-133	*		*	
Mn-52	*		*	
Mn-54	*		*	
Na-22	*		14. E0	13.5 E-6
Np-237	*		*	
Pu-238	93. E0	84. E-3	5.5 E0	5.3 E-6
Pu-239	26. E0	23.5 E-3	2.6 E0	2.5 E-6
Ra-226	*		*	
Ra-228	*		*	
Rb-83	*		*	
Rb-84	*		*	
Sc-46	*		*	
Sc-48	*		*	
Se-75	*		*	
Sn-113	19. E-3	17.2 E-6	*	
Sr-85	42. E-3	37.9 E-6	*	
Sr-89	*		*	
Sr-90	120. E-3	108.4 E-6	*	
TRITIUM			15. E3	14.5 E-3
Th-232	80. E-6	72.2 E-9	*	
U-234	71.5 E-3	64.6 E-6	*	
U-235	1.5 E-3	1.3 E-6	*	
U-238	49.3 E-3	44.5 E-6	110. E-3	106.2 E-9
V-48	*		*	
Y-88	16. E-3	14.4 E-6	*	
Zn-65	*		*	
<b>Total Alpha</b>		<b>144.6 E-3</b>		<b>15.8 E-6</b>
Volume of Flow: Influent = 903048 liters Final = 965000 liters				
* Less than Detection Limit.				
Issued 01/09/2004 10:36:24				

<b>TA50 RADIOISOTOPES</b>				
Summary for APR-2003				
	RAW nCi/L	RAW Total (Ci)	FINAL pCi/L	FINAL Total (Ci)
ALPHA	400. E0	419.5 E-3	8.2 E0	8.4 E-6
Am-241	140. E0	146.8 E-3	5.1 E0	5.2 E-6
As-74	*		*	
BETA	16. E0	16.8 E-3	150. E0	153.8 E-6
Be-7	*		*	
Ce-141	*		*	
Co-56	*		*	
Co-57	*		*	
Co-58	*		*	
Co-60	*		*	
Cs-134	*		*	
Cs-137	*		*	
Eu-152	*		*	
I-133	*		*	
Mn-52	*		*	
Mn-54	*		*	
Na-22	*		*	
Np-237	*		*	
Pu-238	160. E0	167.8 E-3	12. E0	12.3 E-6
Pu-239	54. E0	56.6 E-3	3.1 E0	3.2 E-6
Ra-226	*		*	
Ra-228	*		*	
Rb-83	*		*	
Rb-84	*		*	
Sc-46	*		*	
Sc-48	*		*	
Se-75	*		*	
Sn-113	*		*	
Sr-85	*		*	
Sr-89	*		*	
Sr-90	*		*	
TRITIUM			9.9 E3	10.1 E-3
Th-232	140. E-6	146.8 E-9	*	
U-234	1.1 E0	1.1 E-3	*	
U-235	2.1 E-3	2.2 E-6	*	
U-238	38.2 E-3	40.1 E-6	*	
V-48	*		*	
Y-88	*		*	
Zn-65	*		*	
Total Alpha		372.5 E-3		20.7 E-6
Volume of Flow: Influent = 1048828 liters Final = 1025100 liters				
* Less than Detection Limit.				
Issued 01/09/2004 10:36:24				

TA50 RADIOISOTOPES				
Summary for MAY-2003				
	RAW nCi/L	RAW Total (Ci)	FINAL pCi/L	FINAL Total (Ci)
ALPHA	370. E0	465.8 E-3	8.2 E0	7.9 E-6
Am-241	91. E0	114.6 E-3	980. E-3	938.8 E-9
As-74	*		*	
BETA				
Be-7	*		410. E0	392.8 E-6
Ce-141	*		170. E0	162.9 E-6
Co-56	*		*	
Co-57	*		*	
Co-58	*		*	
Co-60	*		*	
Cs-134	*		*	
Cs-137	*		*	
Eu-152	*		*	
I-133	*		*	
Mn-52	*		*	
Mn-54	*		*	
Na-22	*		*	
Np-237	900. E-3	1.1 E-3	*	
Pu-238	140. E0	176.3 E-3	7.3 E0	7. E-6
Pu-239	59. E0	74.3 E-3	1.7 E0	1.6 E-6
Ra-226	*		*	
Ra-228	*		*	
Rb-83	*		*	
Rb-84	*		*	
Sc-46	*		*	
Sc-48	*		*	
Se-75	*		*	
Sn-113	*		*	
Sr-85	*		40. E0	38.3 E-6
Sr-89	*		*	
Sr-90	*		*	
TRITIUM			9.2 E3	8.8 E-3
Th-232	150. E-6	188.9 E-9	*	
U-234	447. E-3	562.8 E-6	*	
U-235	1.4 E-3	1.8 E-6	*	
U-238	39.4 E-3	49.6 E-6	*	
V-48	*		*	
Y-88	*		*	
Zn-65	*		*	
Total Alpha		366.9 E-3		9.6 E-6
Volume of Flow: Influent = 1259010 liters Final = 958000 liters				
* Less than Detection Limit.				
Issued 01/09/2004 10:36:24				

<b>TA50 RADIOISOTOPES</b>				
Summary for JUN-2003				
	RAW nCi/L	RAW Total (Ci)	FINAL pCi/L	FINAL Total (Ci)
ALPHA	120. E0	153.4 E-3	*	
Am-241	36. E0	46. E-3	10. E0	14.7 E-6
As-74	*		360. E0	530.2 E-6
BETA	*		*	
Be-7	*		*	
Ce-141	*		*	
Co-56	*		*	
Co-57	*		*	
Co-58	*		*	
Co-60	*		*	
Cs-134	*		*	
Cs-137	*		*	
Eu-152	*		*	
I-133	*		*	
Mn-52	*		*	
Mn-54	*		*	
Na-22	*		*	
Np-237	*		*	
Pu-238	54. E0	69. E-3	3.5 E0	5.2 E-6
Pu-239	41. E0	52.4 E-3	*	
Ra-226	*		*	
Ra-228	*		*	
Rb-83	*		*	
Rb-84	*		*	
Sc-46	*		*	
Sc-48	*		*	
Se-75	*		*	
Sn-113	*		*	
Sr-85	*		*	
Sr-89	*		*	
Sr-90	*		*	
TRITIUM			12. E3	17.7 E-3
Th-232	160. E-6	204.5 E-9	*	
U-234	59.1 E-3	75.5 E-6	*	
U-235	640. E-6	818.1 E-9	*	
U-238	56.4 E-3	72.1 E-6	*	
V-48	*		*	
Y-88	*		*	
Zn-65	*		*	
Total Alpha		167.6 E-3		19.9 E-6
				6
Volume of Flow: Influent = 1278221 liters Final = 1472800 liters				
* Less than Detection Limit.				
Issued 01/09/2004 10:36:24				

<b>TA50 RADIOISOTOPES</b>				
Summary for JUL-2003				
	RAW nCi/L	RAW Total (Ci)	FINAL pCi/L	FINAL Total (Ci)
ALPHA	190. E0	199.1 E-3	15. E0	18.3 E-6
Am-241	100. E0	104.8 E-3	6. E0	7.3 E-6
As-74	*		84. E0	102.4 E-6
BETA	8.9 E0	9.3 E-3	72. E0	87.8 E-6
Be-7	*		*	
Ce-141	*		*	
Co-56	*		*	
Co-57	*		*	
Co-58	*		*	
Co-60	*		*	
Cs-134	*		*	
Cs-137	*		10. E0	12.2 E-6
Eu-152	*		*	
I-133	*		*	
Mn-52	*		*	
Mn-54	*		*	
Na-22	*		*	
Np-237	*		*	
Pu-238	68. E0	71.2 E-3	15. E0	18.3 E-6
Pu-239	40. E0	41.9 E-3	7.7 E0	9.4 E-6
Ra-226	*		*	
Ra-228	*		*	
Rb-83	*		*	
Rb-84	*		*	
Sc-46	*		*	
Sc-48	*		*	
Se-75	*		*	
Sn-113	*		*	
Sr-85	*		*	
Sr-89	*		*	
Sr-90	*		*	
TRITIUM			11. E3	13.4 E-3
Th-232	430. E-6	450.5 E-9	*	
U-234	112. E-3	117.3 E-6	*	
U-235	1.8 E-3	1.8 E-6	*	
U-238	44.3 E-3	46.4 E-6	*	
V-48	*		*	
Y-88	*		*	
Zn-65	*		*	
Total Alpha		218.1 E-3		35. E-6

Volume of Flow: Influent = 1047767 liters Final = 1218800 liters

\* Less than Detection Limit.

Issued 01/09/2004 10:36:24

<b>TA50 RADIOISOTOPES</b>				
Summary for AUG-2003				
	RAW nCi/L	RAW Total (Ci)	FINAL pCi/L	FINAL Total (Ci)
ALPHA	90. E0	89.5 E-3	*	
Am-241	56. E0	55.7 E-3	3.1 E0	2.7 E-6
As-74	*		32. E0	28.1 E-6
BETA	26. E0	25.8 E-3	85. E0	74.7 E-6
Be-7	*		*	
Ce-141	*		*	
Co-56	*		*	
Co-57	*		*	
Co-58	*		*	
Co-60	*		*	
Cs-134	*		*	
Cs-137	*		13. E0	11.4 E-6
Eu-152	*		*	
I-133	*		*	
Mn-52	*		*	
Mn-54	*		*	
Na-22	*		*	
Np-237	*		*	
Pu-238	39. E0	38.8 E-3	18. E0	15.8 E-6
Pu-239	29. E0	28.8 E-3	6.6 E0	5.8 E-6
Ra-226	*		*	
Ra-228	*		5.3 E0	4.7 E-6
Rb-83	*		*	
Rb-84	*		*	
Sc-46	*		*	
Sc-48	*		*	
Se-75	*		*	
Sn-113	*		*	
Sr-85	*		*	
Sr-89	*		*	
Sr-90	*		*	
TRITIUM			8.2 E3	7.2 E-3
Th-232	580. E-6	576.5 E-9	50. E-3	43.9 E-9
U-234	66.6 E-3	66.2 E-6	*	
U-235	770. E-6	765.4 E-9	*	
U-238	27.9 E-3	27.7 E-6	*	
V-48	*		*	
Y-88	*		*	
Zn-65	*		*	
Total Alpha		123.4 E-3		24.4 E-6
Volume of Flow: Influent = 993992 liters Final = 878354 liters				
* Less than Detection Limit.				
Issued 01/09/2004 10:36:24				

<b>TA50 RADIOISOTOPES</b>				
Summary for SEP-2003				
	RAW nCi/L	RAW Total (Ci)	FINAL pCi/L	FINAL Total (Ci)
ALPHA	100. E0	87.1 E-3	4.7 E0	4.2 E-6
Am-241	87. E0	75.8 E-3	5.3 E0	4.7 E-6
As-74	*		39. E0	34.6 E-6
BETA	11. E0	9.6 E-3	26. E0	23.1 E-6
Be-7	*		*	
Ce-141	*		*	
Co-56	*		*	
Co-57	*		*	
Co-58	*		*	
Co-60	*		*	
Cs-134	*		*	
Cs-137	*		15. E0	13.3 E-6
Eu-152	*		*	
I-133	*		*	
Mn-52	*		*	
Mn-54	*		*	
Na-22	*		*	
Np-237	*		*	
Pu-238	31. E0	27. E-3	14. E0	12.4 E-6
Pu-239	20. E0	17.4 E-3	5.1 E0	4.5 E-6
Ra-226	*		*	
Ra-228	*		5.5 E0	4.9 E-6
Rb-83	*		*	
Rb-84	*		*	
Sc-46	*		*	
Sc-48	*		*	
Se-75	*		*	
Sn-113	*		*	
Sr-85	*		*	
Sr-89	*		*	
Sr-90	*		*	
TRITIUM			6.2 E3	5.5 E-3
Th-232	500. E-6	435.6 E-9	30. E-3	26.6 E-9
U-234	5.7 E0	5. E-3	*	
U-235	1.2 E-3	1. E-6	*	
U-238	28. E-3	24.4 E-6	*	
V-48	*		*	
Y-88	*		*	
Zn-65	*		*	
Total Alpha		125.2 E-3		21.7 E-6

Volume of Flow: Influent = 871207 liters Final = 888000 liters

\* Less than Detection Limit.

Issued 01/09/2004 10:36:24

<b>TA50 RADIOISOTOPES</b>				
Summary for OCT-2003				
	RAW nCi/L	RAW Total (Ci)	FINAL pCi/L	FINAL Total (Ci)
ALPHA	86. E0	72.6 E-3	13. E0	8.4 E-6
Am-241	59. E0	49.8 E-3	*	
As-74	*		34. E0	22. E-6
BETA			*	
Be-7	*		*	
Ce-141	*		*	
Co-56	*		*	
Co-57	*		*	
Co-58	*		*	
Co-60	*		*	
Cs-134	*		*	
Cs-137	*		*	
Eu-152	*		*	
I-133	*		*	
Mn-52	*		*	
Mn-54	*		*	
Na-22	*		*	
Np-237	*		*	
Pu-238	23. E0	19.4 E-3	7.9 E0	5.1 E-6
Pu-239	19. E0	16. E-3	2.7 E0	1.8 E-6
Ra-226	*		*	
Ra-228	*		*	
Rb-83	*		*	
Rb-84	*		*	
Sc-46	*		*	
Sc-48	*		*	
Se-75	*		*	
Sn-113	*		*	
Sr-85	*		*	
Sr-89	*		*	
Sr-90	*		*	
TRITIUM			12. E3	7.8 E-3
Th-232	*		*	
U-234	745. E-3	628.8 E-6	*	
U-235	500. E-6	422. E-9	*	
U-238	23. E-3	19.4 E-6	*	
V-48	*		*	
Y-88	*		*	
Zn-65	*		*	
Total Alpha		85.9 E-3		6.9 E-6
Volume of Flow: Influent = 844081 liters Final = 648200 liters				
* Less than Detection Limit.				
Issued 01/09/2004 10:36:24				



<b>TA50 RADIOISOTOPES</b>				
Summary for NOV-2003				
	RAW nCi/L	RAW Total (Ci)	FINAL pCi/L	FINAL Total (Ci)
ALPHA	47. E0	51.6 E-3	15. E0	10.9 E-6
Am-241	58. E0	63.7 E-3	3.8 E0	2.8 E-6
As-74	*		*	
BETA			26. E0	18.9 E-6
Be-7	*		*	
Ce-141	*		*	
Co-56	*		*	
Co-57	*		*	
Co-58	*		*	
Co-60	*		*	
Cs-134	*		*	
Cs-137	*		9.1 E0	6.6 E-6
Eu-152	*		*	
I-133	*		*	
Mn-52	*		*	
Mn-54	*		*	
Na-22	*		*	
Np-237	*		*	
Pu-238	*		12. E0	8.7 E-6
Pu-239	20. E0	22. E-3	6.1 E0	4.4 E-6
Ra-226	*		*	
Ra-228	*		*	
Rb-83	*		*	
Rb-84	*		*	
Sc-46	*		*	
Sc-48	*		*	
Se-75	*		*	
Sn-113	*		*	
Sr-85	*		*	
Sr-89	*		*	
Sr-90	*		*	
TRITIUM			12. E3	8.7 E-3
Th-232	270. E-6	296.7 E-9	30. E-3	21.8 E-9
U-234	368. E-3	404.4 E-6	*	
U-235	610. E-6	670.3 E-9	*	
U-238	35.4 E-3	38.9 E-6	*	
V-48	*		*	
Y-88	*		*	
Zn-65	*		*	
Total Alpha		86.2 E-3		15.9 E-6
Volume of Flow: Influent = 1098827 liters Final = 725600 liters				
* Less than Detection Limit.				
Issued 01/20/2004 11:18:55				

TA50 RADIOISOTOPES				
Summary for DEC-2003				
	RAW nCi/L	RAW Total (Ci)	FINAL pCi/L	FINAL Total (Ci)
ALPHA	48. E0	44.8 E-3	9.5 E0	4.6 E-6
Am-241	42. E0	39.2 E-3	*	
As-74	*		*	
BETA			39. E0	18.8 E-6
Be-7	*		*	
Ce-141	*		*	
Co-56	*		*	
Co-57	*		*	
Co-58	*		*	
Co-60	*		*	
Cs-134	*		*	
Cs-137	*		11. E0	5.3 E-6
Eu-152	*		*	
I-133	*		*	
Mn-52	*		*	
Mn-54	*		*	
Na-22	*		*	
Np-237	*		*	
Pu-238	19. E0	17.7 E-3	14. E0	6.7 E-6
Pu-239	12. E0	11.2 E-3	3.9 E0	1.9 E-6
Ra-226	*		*	
Ra-228	*		*	
Rb-83	*		*	
Rb-84	*		*	
Sc-46	*		*	
Sc-48	*		*	
Se-75	*		*	
Sn-113	*		*	
Sr-85	120. E-3	111.9 E-6	*	
Sr-89	*		*	
Sr-90	*		*	
TRITIUM			11. E3	5.3 E-3
Th-232	150. E-6	139.9 E-9	*	
U-234	506. E-3	471.8 E-6	*	
U-235	890. E-6	829.9 E-9	*	
U-238	45.6 E-3	42.5 E-6	*	
V-48	*		*	
Y-88	*		*	
Zn-65	*		*	
Total Alpha		68.6 E-3		9.6 E-6
Volume of Flow: Influent = 932434 liters Final = 481700 liters				
* Less than Detection Limit.				
Issued 01/27/2004 09:56:46				

**Appendix D**

**TA-50 RLWTF Monthly Mineral Summary for CY 2003**

<b>TA50 MINERALS</b>				
Summary for JAN-2003				
	RAW		FINAL	
	Concentration	Total (Kg)	Concentration	Total (Kg)
ALKALINITY-MO**	145. E0	166.9 E0	284. E0	335.8 E0
ALKALINITY-P**	7.2 E0	8.3 E0	*	
ALUMINUM	1. E0	1.2 E0	21. E-3	25. E-3
AMMONIA-N	5.5 E0	6.3 E0	4.8 E0	5.7 E0
ARSENIC	8. E-3	9. E-3	10. E-3	12. E-3
BARIUM	4. E-3	5. E-3	*	
BERYLLIUM	5. E-3	6. E-3	*	
BORON	90. E-3	104. E-3	80. E-3	95. E-3
CADMIUM	4. E-3	5. E-3	*	
CALCIUM	19. E0	21.9 E0	2. E0	2.4 E0
CHLORIDE	26.5 E0	30.5 E0	27. E0	31.9 E0
COBALT	*		*	
COD	77. E0	88.6 E0	36. E0	42.6 E0
CONDUCTIVITY**	464. E0		840. E0	
COPPER	6. E0	6.9 E0	40. E-3	47. E-3
CYANIDE	23. E-3	26. E-3	4. E-3	5. E-3
FLUORIDE	550. E-3	633. E-3	720. E-3	851. E-3
HARDNESS**	76.3 E0	87.8 E0	5.2 E0	6.1 E0
IRON	1. E0	1.2 E0	23. E-3	27. E-3
LEAD	130. E-3	150. E-3	*	
MAGNESIUM	7. E0	8.1 E0	50. E-3	59. E-3
MERCURY	3. E-3	3. E-3	40. E-6	47.3 E-6
NICKEL	60. E-3	69. E-3	*	
NITRATE-N	4.5 E0	5.2 E0	320. E-3	378. E-3
NITRITE-N	810. E-3	932. E-3	740. E-3	875. E-3
PERCHLORATE	135. E-3	155. E-3	*	
PHOSPHORUS	4.2 E0	4.9 E0	186. E-3	220. E-3
POTASSIUM	7.4 E0	8.5 E0	7.5 E0	8.9 E0
SELENIUM	*		*	
SILICON	36. E0	41.4 E0	12. E0	14.2 E0
SILVER	9. E-3	10. E-3	*	
SODIUM	70. E0	80.6 E0	179. E0	211.7 E0
SULFATE	33. E0	38. E0	98. E0	115.9 E0
TDS	150. E0	172.6 E0	338. E0	399.7 E0
TKN	38.7 E0	44.5 E0	4.9 E0	5.8 E0
TOTAL CATIONS**	4.8 E0		8.8 E0	
TOTAL CHROMIUM	30. E-3	35. E-3	*	
TOXIC ORGANICS**			1.4 E0	2. E-3
TSS	48. E0	55.2 E0	*	
URANIUM	76. E-3	87. E-3	400. E-6	473. E-6
VANADIUM	30. E-3	35. E-3	20. E-3	24. E-3
ZINC	150. E-3	173. E-3	*	
pH	8.1 E0		7.6 E0	

Volume of Flow: Influent = 1150951 liters Final = 1182460 liters

\*\*Alkalinities and hardness as mg CaCO3/l; Conductivity as uS/cm;  
 Total Cations as meq/l; Toxic Organics as ug/l; Otherwise: mg/l.

\* Less than Detection Limit

Issued 02/17/2004 14:36:06

<b>TA50 MINERALS</b>				
Summary for FEB-2003				
	RAW		FINAL	
	Concentration	Total (Kg)	Concentration	Total (Kg)
ALKALINITY-MO**	67.7 E0	49.3 E0	267. E0	217.2 E0
ALKALINITY-P**	*		*	
ALUMINUM	3.5 E0	2.6 E0	24. E-3	20. E-3
AMMONIA-N	5. E0	3.6 E0	4.4 E0	3.5 E0
ARSENIC	*		*	
BARIUM	50. E-3	36. E-3	*	
BERYLLIUM	3. E-3	2. E-3	*	
BORON	115. E-3	84. E-3	90. E-3	73. E-3
CADMIUM	4. E-3	3. E-3	*	
CALCIUM	19. E0	13.8 E0	1.7 E0	1.4 E0
CHLORIDE	28. E0	20.4 E0	16. E0	13. E0
COBALT	1. E-3	727.7 E-6	*	
COD	112. E0	81.5 E0	33. E0	26.8 E0
CONDUCTIVITY**	358. E0		658. E0	
COPPER	850. E-3	619. E-3	40. E-3	33. E-3
CYANIDE	*		*	
FLUORIDE	600. E-3	437. E-3	450. E-3	366. E-3
HARDNESS**	69.3 E0	50.4 E0	4.4 E0	3.6 E0
IRON	1.3 E0	946. E-3	30. E-3	24. E-3
LEAD	130. E-3	95. E-3	*	
MAGNESIUM	5.3 E0	3.9 E0	40. E-3	33. E-3
MERCURY	2. E-3	1. E-3	92. E-6	74.8 E-6
NICKEL	450. E-3	327. E-3	*	
NITRATE-N	9.1 E0	6.6 E0	330. E-3	268. E-3
NITRITE-N	740. E-3	539. E-3	1.4 E0	1.1 E0
PERCHLORATE	29. E-3	21. E-3	*	
PHOSPHORUS	2.3 E0	1.7 E0	90. E-3	73. E-3
POTASSIUM	5. E0	3.6 E0	3.8 E0	3.1 E0
SELENIUM	*		*	
SILICON	34. E0	24.7 E0	10. E0	8.1 E0
SILVER	25. E-3	18. E-3	3. E-3	2. E-3
SODIUM	32. E0	23.3 E0	142. E0	115.5 E0
SULFATE	19. E0	13.8 E0	46. E0	37.4 E0
TDS	110. E0	80. E0	256. E0	208.2 E0
TKN	8.6 E0	6.3 E0	5.6 E0	4.6 E0
TOTAL CATIONS**	3.4 E0		6.8 E0	
TOTAL CHROMIUM	23. E-3	17. E-3	*	
TOXIC ORGANICS**			1.2 E0	976. E-6
TSS	31. E0	22.6 E0	*	
URANIUM	56. E-3	41. E-3	*	
VANADIUM	220. E-3	160. E-3	150. E-3	122. E-3
ZINC	20. E-3	15. E-3	10. E-3	8. E-3
pH	6.9 E0		8. E0	

Volume of Flow: Influent = 727717 liters Final = 813300 liters

\*\*Alkalinities and hardness as mg CaCO3/l; Conductivity as uS/cm;  
 Total Cations as meq/l; Toxic Organics as ug/l; Otherwise: mg/l.

\* Less than Detection Limit

Issued 02/11/2004 16:06:54

<b>TA50 MINERALS</b>				
Summary for MAR-2003				
	RAW		FINAL	
	Concentration	Total (Kg)	Concentration	Total (Kg)
ALKALINITY-MO**	82.2 E0	74.2 E0	223. E0	215.2 E0
ALKALINITY-P**	*		*	
ALUMINUM	577. E-3	521. E-3	18. E-3	17. E-3
AMMONIA-N	2.7 E0	2.4 E0	3.8 E0	3.6 E0
ARSENIC	*		*	
BARIUM	35. E-3	32. E-3	*	
BERYLLIUM	*		*	
BORON	92. E-3	83. E-3	98. E-3	95. E-3
CADMIUM	*		*	
CALCIUM	15. E0	13.5 E0	*	
CHLORIDE	18. E0	16.3 E0	21. E0	20.3 E0
COBALT	*		*	
COD	81. E0	73.1 E0	18. E0	17.4 E0
CONDUCTIVITY**	320. E0		620. E0	
COPPER	219. E-3	198. E-3	37. E-3	36. E-3
CYANIDE	*		*	
FLUORIDE	800. E-3	722. E-3	1.4 E0	1.3 E0
HARDNESS**	58. E0	52.4 E0	*	
IRON	*		*	
LEAD	40. E-3	36. E-3	*	
MAGNESIUM	5. E0	4.5 E0	*	
MERCURY	3. E-3	3. E-3	80. E-6	77.2 E-6
NICKEL	30. E-3	27. E-3	*	
NITRATE-N	830. E-3	750. E-3	4.4 E0	4.2 E0
NITRITE-N	1.8 E0	1.6 E0	610. E-3	589. E-3
PERCHLORATE	380. E-3	343. E-3	*	
PHOSPHORUS	2.8 E0	2.5 E0	58. E-3	56. E-3
POTASSIUM	7. E0	6.3 E0	3.2 E0	3.1 E0
SELENIUM	*		*	
SILICON	35. E0	31.6 E0	12. E0	11.6 E0
SILVER	7. E-3	6. E-3	*	
SODIUM	39. E0	35.2 E0	123. E0	118.7 E0
SULFATE	57. E0	51.5 E0	15. E0	14.5 E0
TDS	*		190. E0	183.4 E0
TKN	5. E0	4.5 E0	5.2 E0	5. E0
TOTAL CATIONS**	3.1 E0		6.3 E0	
TOTAL CHROMIUM	*		*	
TOXIC ORGANICS**			1.1 E0	1. E-3
TSS	11. E0	9.9 E0	*	
URANIUM	147. E-3	133. E-3	320. E-6	308.8 E-6
VANADIUM	20. E-3	18. E-3	*	
ZINC	120. E-3	108. E-3	*	
pH	6.9 E0		7.4 E0	

Volume of Flow: Influent = 903048 liters Final = 965000 liters

\*\*Alkalinities and hardness as mg CaCO<sub>3</sub>/l; Conductivity as uS/cm;  
Total Cations as meq/l; Toxic Organics as ug/l; Otherwise: mg/l.

\* Less than Detection Limit

Issued 02/17/2004 14:36:06

**TA50 MINERALS**

Summary for JUN-2003

	RAW		FINAL	
	Concentration	Total (Kg)	Concentration	Total (Kg)
ALKALINITY-MO**	58. E0	74.1 E0	42.2 E0	62.2 E0
ALKALINITY-P**	*		*	
ALUMINIUM	292. E-3	373. E-3	26. E-3	38. E-3
AMMONIA-N	4. E0	5.1 E0	3.8 E0	5.6 E0
ARSENIC	*		*	
BARIUM	35. E-3	45. E-3	*	
BERYLLIUM	5. E-3	6. E-3	*	
BORON	140. E-3	179. E-3	52. E-3	77. E-3
CADMIUM	5. E-3	6. E-3	*	
CALCIUM	8. E0	10.2 E0	130. E-3	191. E-3
CHLORIDE	14. E0	17.9 E0	980. E-3	1.4 E0
COBALT	*		*	
COD	108. E0	138. E0	38. E0	56. E0
CONDUCTIVITY**	247. E0		149. E0	
COPPER	182. E-3	233. E-3	11. E-3	16. E-3
CYANIDE	20. E-3	26. E-3	*	
FLUORIDE	230. E-3	294. E-3	*	
HARDNESS**	32.3 E0	41.3 E0	324.6 E-3	478. E-3
IRON	1.5 E0	1.9 E0	74. E-3	109. E-3
LEAD	50. E-3	64. E-3	*	
MAGNESIUM	3. E0	3.8 E0	*	
MERCURY	6.2 E-3	8. E-3	*	
NICKEL	50. E-3	64. E-3	*	
NITRATE-N	3.3 E0	4.2 E0	*	
NITRITE-N	350. E-3	447. E-3	*	
PERCHLORATE	39. E-3	50. E-3	*	
PHOSPHORUS	1.9 E0	2.4 E0	20. E-3	29. E-3
POTASSIUM	500. E-3	639. E-3	*	
SELENIUM	*		*	
SILICON	33. E0	42.2 E0	*	
SILVER	33. E-3	42. E-3	8. E-3	12. E-3
SODIUM	18. E0	23. E0	16. E0	23.6 E0
SULFATE	18. E0	23. E0	23. E0	33.9 E0
TDS	*		*	
TKN	7.5 E0	9.5 E0	4.4 E0	6.4 E0
TOTAL CATIONS**	2.3 E0		1.3 E0	
TOTAL CHROMIUM	31. E-3	40. E-3	*	
TOXIC ORGANICS**			1. E0	1. E-3
TSS	18. E0	23. E0	*	
URANIUM	56.6 E-3	72. E-3	*	
VANADIUM	12. E-3	15. E-3	*	
ZINC	110. E-3	141. E-3	9. E-3	13. E-3
pH	6.5 E0		7.3 E0	

Volume of Flow: Influent = 1278221 liters Final = 1472800 liters

\*\*Alkalinities and hardness as mg CaCO3/l; Conductivity as uS/cm;  
Total Cations as meq/l; Toxic Organics as ug/l; Otherwise: mg/l.

\* Less than Detection Limit

Issued 02/17/2004 14:36:06

<b>TA50 MINERALS</b>				
Summary for JUL-2003				
	RAW		FINAL	
	Concentration	Total (Kg)	Concentration	Total (Kg)
ALKALINITY-MO**	148. E0	155.1 E0	70.5 E0	85.9 E0
ALKALINITY-P**	*		*	
ALUMINUM	965. E-3	1. E0	69. E-3	84. E-3
AMMONIA-N	3.5 E0	3.7 E0	5.8 E0	7.1 E0
ARSENIC	9. E-3	9. E-3	15. E-3	18. E-3
BARIUM	43. E-3	45. E-3	*	
BERYLLIUM	6. E-3	6. E-3	*	
BORON	59. E-3	62. E-3	43. E-3	52. E-3
CADMIUM	4. E-3	4. E-3	*	
CALCIUM	10. E0	10.5 E0	*	
CHLORIDE	20. E0	21. E0	5.7 E0	6.9 E0
COBALT	*		*	
COD	146. E0	153. E0	38. E0	46.3 E0
CONDUCTIVITY**	606. E0		267. E0	
COPPER	440. E-3	461. E-3	14. E-3	17. E-3
CYANIDE	3. E-3	3. E-3	*	
FLUORIDE	700. E-3	733. E-3	210. E-3	256. E-3
HARDNESS**	37.3 E0	39.1 E0	*	
IRON	2.8 E0	2.9 E0	171. E-3	208. E-3
LEAD	90. E-3	94. E-3	*	
MAGNESIUM	3. E0	3.1 E0	*	
MERCURY	9.1 E-3	10. E-3	20. E-6	24.4 E-6
NICKEL	60. E-3	63. E-3	*	
NITRATE-N	4.3 E0	4.5 E0	*	
NITRITE-N	810. E-3	849. E-3	*	
PERCHLORATE	31. E-3	32. E-3	*	
PHOSPHORUS	28. E-3	29. E-3	50. E-3	61. E-3
POTASSIUM	9. E0	9.4 E0	1.4 E0	1.7 E0
SELENIUM	*		*	
SILICON	34. E0	35.6 E0	1. E0	1.2 E0
SILVER	43. E-3	45. E-3	7. E-3	9. E-3
SODIUM	90. E0	94.3 E0	40. E0	48.8 E0
SULFATE	100. E0	104.8 E0	47. E0	57.3 E0
TDS	372. E0	389.8 E0	*	
TKN	10. E0	10.5 E0	7.9 E0	9.6 E0
TOTAL CATIONS**	6.2 E0		2.5 E0	
TOTAL CHROMIUM	40. E-3	42. E-3	*	
TOXIC ORGANICS**			*	
TSS	30. E0	31.4 E0	*	
URANIUM	132. E-3	138. E-3	*	
VANADIUM	170. E-3	178. E-3	*	
ZINC	170. E-3	178. E-3	10. E-3	12. E-3
pH	7.3 E0		7.5 E0	

Volume of Flow: Influent = 1047767 liters Final = 1218800 liters

\*\*Alkalinities and hardness as mg CaCO<sub>3</sub>/l; Conductivity as uS/cm;  
Total Cations as meq/l; Toxic Organics as ug/l; Otherwise: mg/l.

\* Less than Detection Limit

Issued 02/17/2004 14:36:06



TA50 MINERALS				
Summary for AUG-2003				
	RAW		FINAL	
	Concentration	Total (Kg)	Concentration	Total (Kg)
ALKALINITY-MO**	42.2 E0	41.9 E0	87.6 E0	76.9 E0
ALKALINITY-P**	*		*	
ALUMINUM	259. E-3	257. E-3	116. E-3	102. E-3
AMMONIA-N	3.4 E0	3.4 E0	3. E0	2.6 E0
ARSENIC	*		*	
BARIUM	32. E-3	32. E-3	*	
BERYLLIUM	2. E-3	2. E-3	*	
BORON	42. E-3	42. E-3	91. E-3	80. E-3
CADMIUM	7. E-3	7. E-3	3. E-3	3. E-3
CALCIUM	9. E0	8.9 E0	*	
CHLORIDE	23. E0	22.9 E0	4. E0	3.5 E0
COBALT	*		*	
COD	85. E0	84.5 E0	37. E0	32.5 E0
CONDUCTIVITY**	246. E0		220. E0	
COPPER	364. E-3	362. E-3	12. E-3	11. E-3
CYANIDE	*		*	
FLUORIDE	510. E-3	507. E-3	290. E-3	255. E-3
HARDNESS**	34.8 E0	34.6 E0	*	
IRON	1.2 E0	1.2 E0	100. E-3	88. E-3
LEAD	66. E-3	66. E-3	*	
MAGNESIUM	3. E0	3. E0	*	
MERCURY	4.6 E-3	5. E-3	40. E-6	35.1 E-6
NICKEL	64. E-3	64. E-3	*	
NITRATE-N	5.9 E0	5.9 E0	80. E-3	70. E-3
NITRITE-N	171. E-3	170. E-3	300. E-3	264. E-3
PERCHLORATE	65. E-3	65. E-3	*	
PHOSPHORUS	1.5 E0	1.5 E0	*	
POTASSIUM	4. E0	4. E0	*	
SELENIUM	*		*	
SILICON	29. E0	28.8 E0	2. E0	1.8 E0
SILVER	20. E-3	20. E-3	*	
SODIUM	22. E0	21.9 E0	38. E0	33.4 E0
SULFATE	11. E0	10.9 E0	10. E0	8.8 E0
TDS	200. E0	198.8 E0	*	
TKN	3.3 E0	3.3 E0	3.3 E0	2.9 E0
TOTAL CATIONS**	2.1 E0		2.1 E0	
TOTAL CHROMIUM	30. E-3	30. E-3	1. E-3	878.4 E-6
TOXIC ORGANICS**			*	
TSS	12. E0	11.9 E0	*	
URANIUM	83.5 E-3	83. E-3	*	
VANADIUM	*		*	
ZINC	160. E-3	159. E-3	20. E-3	18. E-3
pH	6.4 E0		7.5 E0	

Volume of Flow: Influent = 993992 liters Final = 878354 liters

\*\*Alkalinities and hardness as mg CaCO<sub>3</sub>/l; Conductivity as uS/cm;  
Total Cations as meq/l; Toxic Organics as ug/l; Otherwise: mg/l.

\* Less than Detection Limit

Issued 02/17/2004 14:36:06

TA50 MINERALS				
Summary for SEP-2003				
	RAW		FINAL	
	Concentration	Total (Kg)	Concentration	Total (Kg)
ALKALINITY-MO**	44. E0	38.3 E0	85.6 E0	76. E0
ALKALINITY-P**	*		*	
ALUMINIUM	1.4 E0	1.2 E0	20. E-3	18. E-3
AMMONIA-N	4. E0	3.5 E0	3.1 E0	2.8 E0
ARSENIC	10. E-3	9. E-3	13. E-3	12. E-3
BARIUM	29. E-3	25. E-3	*	
BERYLLIUM	8. E-3	7. E-3	*	
BORON	60. E-3	52. E-3	48. E-3	43. E-3
CADMIUM	3. E-3	3. E-3	*	
CALCIUM	10. E0	8.7 E0	1. E0	888. E-3
CHLORIDE	26. E0	22.7 E0	5. E0	4.4 E0
COBALT	3. E-3	3. E-3	*	
COD	439. E0	382.5 E0	18. E0	16. E0
CONDUCTIVITY**	270. E0		226. E0	
COPPER	350. E-3	305. E-3	10. E-3	9. E-3
CYANIDE	*		*	
FLUORIDE	700. E-3	610. E-3	240. E-3	213. E-3
HARDNESS**	37.3 E0	32.5 E0	2.5 E0	2.2 E0
IRON	1.2 E0	1. E0	25. E-3	22. E-3
LEAD	92. E-3	80. E-3	*	
MAGNESIUM	3. E0	2.6 E0	*	
MERCURY	3.1 E-3	3. E-3	60. E-6	53.3 E-6
NICKEL	40. E-3	35. E-3	*	
NITRATE-N	*		200. E-3	178. E-3
NITRITE-N	1.7 E0	1.4 E0	700. E-3	622. E-3
PERCHLORATE	142. E-3	124. E-3	*	
PHOSPHORUS	2. E0	1.7 E0	*	
POTASSIUM	11. E0	9.6 E0	2. E0	1.8 E0
SELENIUM	*		*	
SILICON	28. E0	24.4 E0	*	
SILVER	170. E-3	148. E-3	280. E-3	249. E-3
SODIUM	19. E0	16.6 E0	38. E0	33.7 E0
SULFATE	11. E0	9.6 E0	13. E0	11.5 E0
TDS	226. E0	196.9 E0	*	
TKN	11.3 E0	9.8 E0	2.9 E0	2.6 E0
TOTAL CATIONS**	2.2 E0		2.2 E0	
TOTAL CHROMIUM	28. E-3	24. E-3	*	
TOXIC ORGANICS**			*	
TSS	38. E0	33.1 E0	*	
URANIUM	84. E-3	73. E-3	*	
VANADIUM	20. E-3	17. E-3	*	
ZINC	190. E-3	166. E-3	*	
pH	6.2 E0		7.5 E0	
Volume of Flow: Influent = 871207 liters Final = 888000 liters				
**Alkalinities and hardness as mg CaCO3/l; Conductivity as uS/cm;				
Total Cations as meq/l; Toxic Organics as ug/l; Otherwise: mg/l.				
* Less than Detection Limit				
Issued 02/17/2004 14:36:06				

TA50 MINERALS				
Summary for OCT-2003				
	RAW		FINAL	
	Concentration	Total (Kg)	Concentration	Total (Kg)
ALKALINITY-MO**	57.8 E0	48.8 E0	76.4 E0	49.5 E0
ALKALINITY-P**	*		*	
ALUMINUM	270. E-3	228. E-3	83. E-3	54. E-3
AMMONIA-N	4. E0	3.4 E0	3.4 E0	2.2 E0
ARSENIC	*		*	
BARIUM	29. E-3	24. E-3	2. E-3	1. E-3
BERYLLIUM	3. E-3	3. E-3	*	
BORON	20. E-3	17. E-3	*	
CADMIUM	3. E-3	3. E-3	*	
CALCIUM	9. E0	7.6 E0	*	
CHLORIDE	19. E0	16. E0	5.5 E0	3.6 E0
COBALT	2. E-3	2. E-3	4. E-3	3. E-3
COD	116. E0	97.9 E0	62. E0	40.2 E0
CONDUCTIVITY**	230. E0		208. E0	
COPPER	150. E-3	127. E-3	21. E-3	14. E-3
CYANIDE	3. E-3	3. E-3	2. E-3	1. E-3
FLUORIDE	480. E-3	405. E-3	260. E-3	169. E-3
HARDNESS**	34.8 E0	29.4 E0	*	
IRON	1.3 E0	1.1 E0	160. E-3	104. E-3
LEAD	70. E-3	59. E-3	*	
MAGNESIUM	3. E0	2.5 E0	*	
MERCURY	1.9 E-3	2. E-3	40. E-6	25.9 E-6
NICKEL	33. E-3	28. E-3	*	
NITRATE-N	2. E0	1.7 E0	40. E-3	26. E-3
NITRITE-N	200. E-3	169. E-3	100. E-3	65. E-3
PERCHLORATE	490. E-3	414. E-3	*	
PHOSPHORUS	1.6 E0	1.3 E0	*	
POTASSIUM	3. E0	2.5 E0	3. E0	1.9 E0
SELENIUM	*		*	
SILICON	25. E0	21.1 E0	*	
SILVER	20. E-3	17. E-3	3. E-3	2. E-3
SODIUM	19. E0	16. E0	35. E0	22.7 E0
SULFATE	10. E0	8.4 E0	16. E0	10.4 E0
TDS	394. E0	332.6 E0	244. E0	158.2 E0
TKN	6.4 E0	5.4 E0	2.7 E0	1.8 E0
TOTAL CATIONS**	2.2 E0		2.1 E0	
TOTAL CHROMIUM	32. E-3	27. E-3	*	
TOXIC ORGANICS**			*	
TSS	24. E0	20.3 E0	*	
URANIUM	70. E-3	59. E-3	*	
VANADIUM	*		*	
ZINC	90. E-3	76. E-3	30. E-3	19. E-3
pH	6.5 E0		7. E0	

Volume of Flow: Influent = 844081 liters Final = 648200 liters

\*\*Alkalinities and hardness as mg CaCO3/l; Conductivity as uS/cm;  
 Total Cations as meq/l; Toxic Organics as ug/l; Otherwise: mg/l.

\* Less than Detection Limit

Issued 02/17/2004 14:36:06

TA50 MINERALS				
Summary for NOV-2003				
	RAW	Total (Kg)	FINAL	Total (Kg)
	Concentration		Concentration	
ALKALINITY-MO**	34.7 E0	38.1 E0	117. E0	84.9 E0
ALKALINITY-P**	*		*	
ALUMINUM	380. E-3	418. E-3	6. E-3	4. E-3
AMMONIA-N	6.2 E0	6.8 E0	6.4 E0	4.6 E0
ARSENIC	*		*	
BARIUM	34. E-3	37. E-3	*	
BERYLLIUM	3. E-3	3. E-3	*	
BORON	59. E-3	65. E-3	31. E-3	22. E-3
CADMIUM	*		*	
CALCIUM	10. E0	11. E0	400. E-3	290. E-3
CHLORIDE	25. E0	27.5 E0	6.3 E0	4.6 E0
COBALT	1. E-3	1. E-3	*	
COD	117. E0	128.6 E0	20. E0	14.5 E0
CONDUCTIVITY**	284. E0		287. E0	
COPPER	300. E-3	330. E-3	10. E-3	7. E-3
CYANIDE	*		*	
FLUORIDE	680. E-3	747. E-3	610. E-3	443. E-3
HARDNESS**	37.3 E0	41. E0	998.8 E-3	725. E-3
IRON	1.8 E0	2. E0	40. E-3	29. E-3
LEAD	74. E-3	81. E-3	*	
MAGNESIUM	3. E0	3.3 E0	*	
MERCURY	4. E-3	4. E-3	*	
NICKEL	40. E-3	44. E-3	*	
NITRATE-N	6. E0	6.6 E0	40. E-3	29. E-3
NITRITE-N	310. E-3	341. E-3	130. E-3	94. E-3
PERCHLORATE	190. E-3	209. E-3	*	
PHOSPHORUS	1.3 E0	1.4 E0	*	
POTASSIUM	400. E-3	440. E-3	200. E-3	145. E-3
SELENIUM	*		*	
SILICON	25. E0	27.5 E0	*	
SILVER	2. E-3	2. E-3	*	
SODIUM	26. E0	28.6 E0	50. E0	36.3 E0
SULFATE	13. E0	14.3 E0	6. E0	4.4 E0
TDS	*		338. E0	245.3 E0
TKN	8.8 E0	9.7 E0	8.5 E0	6.2 E0
TOTAL CATIONS**	2.2 E0		2.7 E0	
TOTAL CHROMIUM	40. E-3	44. E-3	*	
TOXIC ORGANICS**			*	
TSS	30. E0	33. E0	*	
URANIUM	106. E-3	116. E-3	*	
VANADIUM	10. E-3	11. E-3	*	
ZINC	170. E-3	187. E-3	*	
pH	6.2 E0		7.7 E0	

Volume of Flow: Influent = 1098827 liters Final = 725600 liters

\*\*Alkalinities and hardness as mg CaCO3/l; Conductivity as uS/cm;  
Total Cations as meq/l; Toxic Organics as ug/l; Otherwise: mg/l.

\* Less than Detection Limit

Issued 02/17/2004 14:36:06

<b>TA50 MINERALS</b>				
Summary for DEC-2003				
	RAW Concentration	Total (Kg)	FINAL Concentration	Total (Kg)
ALKALINITY-MO**	212. E0	197.7 E0	135. E0	65. E0
ALKALINITY-P**	*		*	
ALUMINUM	2.7 E0	2.5 E0	10. E-3	5. E-3
AMMONIA-N	6.3 E0	5.9 E0	4.5 E0	2.2 E0
ARSENIC	*		*	
BARIUM	30. E-3	28. E-3	*	
BERYLLIUM	2. E-3	2. E-3	*	
BORON	90. E-3	84. E-3	40. E-3	19. E-3
CADMIUM	3. E-3	3. E-3	*	
CALCIUM	8. E0	7.5 E0	*	
CHLORIDE	77. E0	71.8 E0	10. E0	4.8 E0
COBALT	2. E-3	2. E-3	1. E-3	481.7 E-6
COD	462. E0	430.8 E0	21. E0	10.1 E0
CONDUCTIVITY**	809. E0		363. E0	
COPPER	410. E-3	382. E-3	20. E-3	10. E-3
CYANIDE	*		*	
FLUORIDE	1.4 E0	1.3 E0	410. E-3	197. E-3
HARDNESS**	31.5 E0	29.4 E0	*	
IRON	1.6 E0	1.5 E0	90. E-3	43. E-3
LEAD	90. E-3	84. E-3	*	
MAGNESIUM	2.8 E0	2.6 E0	*	
MERCURY	2.4 E-3	2. E-3	*	
NICKEL	130. E-3	121. E-3	*	
NITRATE-N	6.8 E0	6.3 E0	3.3 E0	1.6 E0
NITRITE-N	1.1 E0	988. E-3	3.6 E0	1.7 E0
PERCHLORATE	160. E-3	149. E-3	*	
PHOSPHORUS	1.4 E0	1.3 E0	20. E-3	10. E-3
POTASSIUM	*		*	
SELENIUM	*		*	
SILICON	11. E0	10.3 E0	*	
SILVER	7. E-3	7. E-3	*	
SODIUM	140. E0	130.5 E0	67. E0	32.3 E0
SULFATE	30. E0	28. E0	12. E0	5.8 E0
TDS	478. E0	445.7 E0	156. E0	75.1 E0
TKN	14. E0	13.1 E0	4.3 E0	2.1 E0
TOTAL CATIONS**	8. E0		3.6 E0	
TOTAL CHROMIUM	70. E-3	65. E-3	*	
TOXIC ORGANICS**			1.1 E0	529.9 E-6
TSS	20. E0	18.6 E0	*	
URANIUM	136. E-3	127. E-3	*	
VANADIUM	10. E-3	9. E-3	*	
ZINC	170. E-3	159. E-3	*	
pH	7.3 E0		7.4 E0	

Volume of Flow: Influent = 932434 liters Final = 481700 liters

\*\*Alkalinities and hardness as mg CaCO3/l; Conductivity as uS/cm;  
 Total Cations as meq/l; Toxic Organics as ug/l; Otherwise: mg/l.

\* Less than Detection Limit

Issued 02/11/2004 16:06:54

**Appendix E**  
**CY 2003 RLWTF Feed VOC Results by Sample**

### RADIOACTIVE LIQUID WASTE TREATMENT FACILITY

VOC results by sample for TA50 Plant Feed  
JAN-2003 through DEC-2003

Sample Date	Sample Number	Species	Concentration (mg/L)	Uncertainty (mg/L)
6-Jan-03	P0103.06	1,3-XYLENE+XYLENE[1,4-]	10. E-3	980. E-6
6-Jan-03	P0103.06	ACETONE	87. E-3	9. E-3
6-Jan-03	P0103.06	CHLOROFORM	4. E-3	400. E-6
6-Jan-03	P0103.06	ETHYLBENZENE	3. E-3	280. E-6
6-Jan-03	P0103.06	METHYLENE CHLORIDE	33. E-3	3. E-3
6-Jan-03	P0103.06	TOLUENE	14. E-3	1. E-3
6-Jan-03	P0103.06	TRICHLOROETHENE	4. E-3	430. E-6
6-Jan-03	P0103.06	XYLENE (TOTAL)	13. E-3	1. E-3
14-Jan-03	P0103.14	ACETONE	760. E-3	76. E-3
14-Jan-03	P0103.14	METHYLENE CHLORIDE	16. E-3	2. E-3
6-Jan-03	P0103.06	1,3-XYLENE+XYLENE[1,4-]	10. E-3	980. E-6
6-Jan-03	P0103.06	ACETONE	87. E-3	9. E-3
21-Jan-03	P0103.21	ACETONE	380. E-3	38. E-3
21-Jan-03	P0103.21	METHYLENE CHLORIDE	13. E-3	1. E-3
28-Jan-03	P0103.28	ACETONE	210. E-3	21. E-3
28-Jan-03	P0103.28	CHLOROFORM	2. E-3	230. E-6
28-Jan-03	P0103.28	METHYLENE CHLORIDE	28. E-3	3. E-3
3-Feb-03	P0203.03	ACETONE	120. E-3	12. E-3
3-Feb-03	P0203.03	METHYLENE CHLORIDE	11. E-3	1. E-3
11-Feb-03	P0203.11	ACETONE	3.1 E0	310. E-3
18-Feb-03	P0203.18	2-BUTANONE	7. E-3	670. E-6
18-Feb-03	P0203.18	ACETONE	1.4 E0	140. E-3
18-Feb-03	P0203.18	METHYLENE CHLORIDE	8. E-3	830. E-6
24-Feb-03	P0203.24	ACETONE	640. E-3	64. E-3
24-Feb-03	P0203.24	METHYLENE CHLORIDE	8. E-3	790. E-6
3-Mar-03	P0303.03	ACETONE	440. E-3	44. E-3
3-Mar-03	P0303.03	METHYL TERT-BUTYL ETHER	76. E-3	8. E-3
3-Mar-03	P0303.03	METHYLENE CHLORIDE	17. E-3	2. E-3
10-Mar-03	P0303.10	ACETONE	630. E-3	63. E-3
10-Mar-03	P0303.10	METHYLENE CHLORIDE	16. E-3	2. E-3
17-Mar-03	P0303.17	ACETONE	610. E-3	61. E-3
17-Mar-03	P0303.17	METHYLENE CHLORIDE	60. E-3	6. E-3
24-Mar-03	P0303.24	ACETONE	300. E-3	30. E-3
24-Mar-03	P0303.24	CHLOROFORM	1. E-3	120. E-6
24-Mar-03	P0303.24	METHYLENE CHLORIDE	3. E-3	330. E-6
31-Mar-03	P0303.31	ACETONE	240. E-3	24. E-3
31-Mar-03	P0303.31	CHLOROFORM	1. E-3	100. E-6
31-Mar-03	P0303.31	METHYLENE CHLORIDE	5. E-3	470. E-6
8-Apr-03	P0403.08	1,2-DICHLOROBENZENE	1. E-3	130. E-6
8-Apr-03	P0403.08	1,2-DICHLOROETHANE	490. E-6	49. E-6
8-Apr-03	P0403.08	4-METHYL-2-PENTANONE	3. E-3	320. E-6
8-Apr-03	P0403.08	ACETONE	560. E-3	56. E-3
8-Apr-03	P0403.08	CHLOROFORM	760. E-6	76. E-6

VOC results by sample for TA50 Plant Feed				Page 2 of 5	
Sample Date	Sample Number	Species	Concentration (mg/L)	Uncertainty (mg/L)	
8-Apr-03	P0403.08	METHYLENE CHLORIDE	4. E-3	420. E-6	
14-Apr-03	P0403.14	ACETONE	560. E-3	56. E-3	
14-Apr-03	P0403.14	CHLOROFORM	6. E-3	610. E-6	
14-Apr-03	P0403.14	METHYLENE CHLORIDE	24. E-3	2. E-3	
1-May-03	P0503.01	ACETONE	1.6 E0	160. E-3	
1-May-03	P0503.01	CHLOROFORM	770. E-6	77. E-6	
1-May-03	P0503.01	METHYLENE CHLORIDE	2. E-3	200. E-6	
5-May-03	P0503.05	2-BUTANONE	12. E-3	1. E-3	
5-May-03	P0503.05	ACETONE	560. E-3	56. E-3	
5-May-03	P0503.05	CHLOROFORM	2. E-3	150. E-6	
12-May-03	P0503.12	ACETONE	78. E-3	8. E-3	
12-May-03	P0503.12	CHLOROFORM	610. E-6	61. E-6	
12-May-03	P0503.12	METHYLENE CHLORIDE	8. E-3	780. E-6	
20-May-03	P0503.20	ACETONE	370. E-3	37. E-3	
20-May-03	P0503.20	CHLOROFORM	1. E-3	110. E-6	
20-May-03	P0503.20	METHYLENE CHLORIDE	2. E-3	190. E-6	
28-May-03	P0503.28	1,2,4-TRIMETHYLBENZENE	2. E-3	230. E-6	
28-May-03	P0503.28	ACETONE	460. E-3	46. E-3	
28-May-03	P0503.28	CHLOROFORM	430. E-6	43. E-6	
28-May-03	P0503.28	METHYLENE CHLORIDE	2. E-3	250. E-6	
2-Jun-03	P0603.02	1,2,4-TRIMETHYLBENZENE	1. E-3	110. E-6	
2-Jun-03	P0603.02	ACETONE	540. E-3	54. E-3	
2-Jun-03	P0603.02	CHLOROFORM	400. E-6	40. E-6	
2-Jun-03	P0603.02	METHYLENE CHLORIDE	4. E-3	400. E-6	
9-Jun-03	P0603.09	1,2,4-TRIMETHYLBENZENE	2. E-3	150. E-6	
9-Jun-03	P0603.09	ACETONE	250. E-3	25. E-3	
9-Jun-03	P0603.09	CHLOROFORM	670. E-6	67. E-6	
9-Jun-03	P0603.09	CHLOROMETHANE	260. E-6	26. E-6	
9-Jun-03	P0603.09	METHYLENE CHLORIDE	790. E-6	79. E-6	
16-Jun-03	P0603.16	1,2,4-TRIMETHYLBENZENE	1. E-3	120. E-6	
16-Jun-03	P0603.16	1,3-XYLENE+XYLENE[1,4-]	1. E-3	100. E-6	
16-Jun-03	P0603.16	ACETONE	510. E-3	51. E-3	
16-Jun-03	P0603.16	CHLOROFORM	1. E-3	110. E-6	
16-Jun-03	P0603.16	METHYLENE CHLORIDE	2. E-3	240. E-6	
23-Jun-03	P0603.23	1,2,4-TRIMETHYLBENZENE	2. E-3	200. E-6	
23-Jun-03	P0603.23	ACETONE	360. E-3	36. E-3	
23-Jun-03	P0603.23	CHLOROFORM	2. E-3	190. E-6	
23-Jun-03	P0603.23	METHYLENE CHLORIDE	6. E-3	610. E-6	
1-Jul-03	P0703.01	1,2,4-TRIMETHYLBENZENE	1. E-3	120. E-6	
1-Jul-03	P0703.01	ACETONE	800. E-3	80. E-3	
1-Jul-03	P0703.01	CHLOROFORM	2. E-3	220. E-6	
1-Jul-03	P0703.01	METHYLENE CHLORIDE	6. E-3	600. E-6	
7-Jul-03	P0703.07	ACETONE	500. E-3	50. E-3	
7-Jul-03	P0703.07	CHLOROFORM	2. E-3	150. E-6	
7-Jul-03	P0703.07	METHYLENE CHLORIDE	8. E-3	810. E-6	
14-Jul-03	P0703.14	1,2,4-TRIMETHYLBENZENE	870. E-6	87. E-6	



VOC results by sample for TA50 Plant Feed				Page 3 of 5	
Sample Date	Sample Number	Species	Concentration (mg/L)	Uncertainty (mg/L)	
14-Jul-03	P0703.14	4-METHYL-2-PENTANONE	24. E-3	2.4 E-3	
14-Jul-03	P0703.14	ACETONE	510. E-3	51. E-3	
14-Jul-03	P0703.14	CHLOROFORM	1.2 E-3	120. E-6	
21-Jul-03	P0703.21	ACETONE	710. E-3	71. E-3	
21-Jul-03	P0703.21	CHLOROFORM	5. E-3	500. E-6	
21-Jul-03	P0703.21	METHYLENE CHLORIDE	66. E-3	6.6 E-3	
28-Jul-03	P0703.28	1,2,4-TRIMETHYLBENZENE	1.1 E-3	110. E-6	
28-Jul-03	P0703.28	ACETONE	500. E-3	50. E-3	
28-Jul-03	P0703.28	CHLOROFORM	1.3 E-3	130. E-6	
28-Jul-03	P0703.28	METHYLENE CHLORIDE	3.8 E-3	380. E-6	
4-Aug-03	P0803.04	ACETONE	390. E-3	39. E-3	
4-Aug-03	P0803.04	CHLOROFORM	740. E-6	74. E-6	
4-Aug-03	P0803.04	METHYLENE CHLORIDE	5.2 E-3	520. E-6	
12-Aug-03	P0803.12	ACETONE	330. E-3	33. E-3	
12-Aug-03	P0803.12	METHYLENE CHLORIDE	2.7 E-3	270. E-6	
18-Aug-03	P0803.18	1,2,4-TRIMETHYLBENZENE	1.3 E-3	130. E-6	
18-Aug-03	P0803.18	1,2-XYLENE	510. E-6	51. E-6	
18-Aug-03	P0803.18	ACETONE	290. E-3	29. E-3	
18-Aug-03	P0803.18	BROMOBENZENE	890. E-6	89. E-6	
18-Aug-03	P0803.18	CHLOROFORM	360. E-6	36. E-6	
18-Aug-03	P0803.18	METHYLENE CHLORIDE	17. E-3	1.7 E-3	
18-Aug-03	P0803.18	N-NITROSO-DI-N-PROPYLAMINE	7.5 E-3	750. E-6	
18-Aug-03	P0803.18	STYRENE	640. E-6	64. E-6	
18-Aug-03	P0803.18	XYLENE (TOTAL)	1.7 E-3	170. E-6	
18-Aug-03	P0803.18	XYLENE[1,3-]+XYLENE[1,4-]	1.2 E-3	120. E-6	
25-Aug-03	P0803.25	2-BUTANONE	15. E-3	1.5 E-3	
25-Aug-03	P0803.25	ACETONE	220. E-3	22. E-3	
25-Aug-03	P0803.25	BROMOBENZENE	820. E-6	82. E-6	
25-Aug-03	P0803.25	CHLOROFORM	490. E-6	49. E-6	
25-Aug-03	P0803.25	METHYLENE CHLORIDE	4.3 E-3	430. E-6	
2-Sep-03	P0903.02	ACETONE	320. E-3	32. E-3	
2-Sep-03	P0903.02	CHLOROFORM	1.2 E-3	120. E-6	
2-Sep-03	P0903.02	METHYLENE CHLORIDE	5.9 E-3	590. E-6	
8-Sep-03	P0903.08	4-METHYL-2-PENTANONE	4. E-3	400. E-6	
8-Sep-03	P0903.08	ACETONE	420. E-3	42. E-3	
8-Sep-03	P0903.08	CHLOROFORM	450. E-6	45. E-6	
8-Sep-03	P0903.08	METHYLENE CHLORIDE	3.6 E-3	360. E-6	
15-Sep-03	P0903.15	ACETONE	590. E-3	59. E-3	
15-Sep-03	P0903.15	CHLOROFORM	960. E-6	96. E-6	
15-Sep-03	P0903.15	METHYLENE CHLORIDE	3.7 E-3	370. E-6	
22-Sep-03	P0903.22	4-METHYL-2-PENTANONE	8.9 E-3	890. E-6	
22-Sep-03	P0903.22	ACETONE	560. E-3	56. E-3	
22-Sep-03	P0903.22	BROMOBENZENE	1.7 E-3	170. E-6	
22-Sep-03	P0903.22	CHLOROFORM	1.2 E-3	120. E-6	
22-Sep-03	P0903.22	METHYLENE CHLORIDE	6.4 E-3	640. E-6	
29-Sep-03	P0903.29	4-METHYL-2-PENTANONE	2.4 E-3	240. E-6	

VOC results by sample for TA50 Plant Feed				Page 4 of 5	
Sample Date	Sample Number	Species	Concentration (mg/L)	Uncertainty (mg/L)	
29-Sep-03	P0903.29	ACETONE	400. E-3	40. E-3	
29-Sep-03	P0903.29	CHLOROFORM	400. E-6	40. E-6	
29-Sep-03	P0903.29	METHYLENE CHLORIDE	5.4 E-3	540. E-6	
15-Oct-03	P1003.15	2-BUTANONE	14. E-3	1.4 E-3	
15-Oct-03	P1003.15	4-METHYL-2-PENTANONE	130. E-3	13. E-3	
15-Oct-03	P1003.15	ACETONE	440. E-3	44. E-3	
15-Oct-03	P1003.15	CHLOROFORM	1.1 E-3	110. E-6	
15-Oct-03	P1003.15	METHYLENE CHLORIDE	5.7 E-3	570. E-6	
20-Oct-03	P1003.20	1,2,4-TRIMETHYLBENZENE	4.4 E-3	440. E-6	
20-Oct-03	P1003.20	4-METHYL-2-PENTANONE	35. E-3	3.5 E-3	
20-Oct-03	P1003.20	ACETONE	170. E-3	17. E-3	
20-Oct-03	P1003.20	CHLOROFORM	1.7 E-3	170. E-6	
20-Oct-03	P1003.20	METHYLENE CHLORIDE	5.7 E-3	570. E-6	
27-Oct-03	P1003.27	4-METHYL-2-PENTANONE	100. E-3	10. E-3	
27-Oct-03	P1003.27	ACETONE	220. E-3	22. E-3	
27-Oct-03	P1003.27	CHLOROFORM	1.6 E-3	160. E-6	
27-Oct-03	P1003.27	METHYLENE CHLORIDE	5.4 E-3	540. E-6	
3-Nov-03	P1103.03	1,2,4-TRIMETHYLBENZENE	3.1 E-3	310. E-6	
3-Nov-03	P1103.03	4-METHYL-2-PENTANONE	39. E-3	3.9 E-3	
3-Nov-03	P1103.03	ACETONE	80. E-3	8. E-3	
3-Nov-03	P1103.03	CHLOROFORM	2. E-3	200. E-6	
3-Nov-03	P1103.03	METHYLENE CHLORIDE	6.5 E-3	650. E-6	
10-Nov-03	P1103.10	1,2,3-TRICHLOROBENZENE	2.6 E-3	260. E-6	
10-Nov-03	P1103.10	1,2,4-TRIMETHYLBENZENE	2.8 E-3	280. E-6	
10-Nov-03	P1103.10	1,3,5-TRIMETHYLBENZENE	650. E-6	65. E-6	
10-Nov-03	P1103.10	4-ISOPROPYLTOLUENE	890. E-6	89. E-6	
10-Nov-03	P1103.10	4-METHYL-2-PENTANONE	22. E-3	2.2 E-3	
10-Nov-03	P1103.10	ACETONE	500. E-3	50. E-3	
10-Nov-03	P1103.10	CHLOROFORM	3.9 E-3	390. E-6	
10-Nov-03	P1103.10	HEXACHLOROBUTADIENE	2. E-3	200. E-6	
10-Nov-03	P1103.10	ISOPROPYLBENZENE	760. E-6	76. E-6	
10-Nov-03	P1103.10	METHYLENE CHLORIDE	6. E-3	600. E-6	
10-Nov-03	P1103.10	SEC-BUTYLBENZENE	900. E-6	90. E-6	
10-Nov-03	P1103.10	TERT-BUTYLBENZENE	820. E-6	82. E-6	
10-Nov-03	P1103.10	TOLUENE	1.2 E-3	120. E-6	
17-Nov-03	P1103.17	4-METHYL-2-PENTANONE	12. E-3	1.2 E-3	
17-Nov-03	P1103.17	ACETONE	280. E-3	28. E-3	
17-Nov-03	P1103.17	CHLOROFORM	5.8 E-3	580. E-6	
17-Nov-03	P1103.17	N-NITROSO-DI-N-PROPYLAMINE	46. E-3	4.6 E-3	
24-Nov-03	P1103.24	1,2,4-TRIMETHYLBENZENE	880. E-6	88. E-6	
24-Nov-03	P1103.24	4-METHYL-2-PENTANONE	16. E-3	1.6 E-3	
24-Nov-03	P1103.24	ACETONE	530. E-3	53. E-3	
24-Nov-03	P1103.24	CHLOROFORM	1.9 E-3	190. E-6	
24-Nov-03	P1103.24	CHLOROMETHANE	2. E-3	200. E-6	
24-Nov-03	P1103.24	METHYLENE CHLORIDE	2.1 E-3	210. E-6	
24-Nov-03	P1103.24	N-NITROSO-DI-N-PROPYLAMINE	44. E-3	4.4 E-3	

VOC results by sample for TA50 Plant Feed				Page 5 of 5	
Sample Date	Sample Number	Species	Concentration (mg/L)	Uncertainty (mg/L)	
2-Dec-03	P1203.02	1,2-DICHLOROETHANE	30. E-3	3. E-3	
2-Dec-03	P1203.02	1,2-XYLENE	1.4 E-3	140. E-6	
2-Dec-03	P1203.02	4-METHYL-2-PENTANONE	150. E-3	15. E-3	
2-Dec-03	P1203.02	ACETONE	290. E-3	29. E-3	
2-Dec-03	P1203.02	BROMOMETHANE	3.5 E-3	350. E-6	
2-Dec-03	P1203.02	CHLOROFORM	1.4 E-3	140. E-6	
2-Dec-03	P1203.02	CHLOROMETHANE	3.9 E-3	390. E-6	
2-Dec-03	P1203.02	CIS-1,2-DICHLOROETHENE	1.6 E-3	160. E-6	
2-Dec-03	P1203.02	CIS/TRANS-1,2-DICHLOROETHENE	1.6 E-3	160. E-6	
2-Dec-03	P1203.02	ETHYLBENZENE	1. E-3	100. E-6	
2-Dec-03	P1203.02	METHYLENE CHLORIDE	2.8 E-3	280. E-6	
2-Dec-03	P1203.02	TOLUENE	4.4 E-3	440. E-6	
2-Dec-03	P1203.02	XYLENE (TOTAL)	5.7 E-3	570. E-6	
2-Dec-03	P1203.02	XYLENE[1,3-]+XYLENE[1,4-]	4.3 E-3	430. E-6	
8-Dec-03	P1203.08	4-METHYL-2-PENTANONE	340. E-3	34. E-3	
8-Dec-03	P1203.08	ACETONE	240. E-3	24. E-3	
8-Dec-03	P1203.08	CHLOROFORM	1. E-3	100. E-6	
8-Dec-03	P1203.08	METHYLENE CHLORIDE	1.7 E-3	170. E-6	
17-Dec-03	P1203.17	1,2,4-TRIMETHYLBENZENE	840. E-6	84. E-6	
17-Dec-03	P1203.17	2-BUTANONE	7.7 E-3	770. E-6	
17-Dec-03	P1203.17	4-METHYL-2-PENTANONE	140. E-3	14. E-3	
17-Dec-03	P1203.17	ACETONE	620. E-3	62. E-3	
17-Dec-03	P1203.17	CHLOROFORM	610. E-6	61. E-6	
17-Dec-03	P1203.17	CHLOROMETHANE	3.6 E-3	360. E-6	
17-Dec-03	P1203.17	DI-N-OCTYL PHTHALATE	2.8 E-3	280. E-6	
17-Dec-03	P1203.17	METHYLENE CHLORIDE	3.7 E-3	370. E-6	
22-Dec-03	P1203.22	4-METHYL-2-PENTANONE	120. E-3	12. E-3	
22-Dec-03	P1203.22	ACETONE	720. E-3	72. E-3	
22-Dec-03	P1203.22	CHLOROFORM	740. E-6	74. E-6	
22-Dec-03	P1203.22	METHYLENE CHLORIDE	9.9 E-3	990. E-6	

Issued 01/27/2004 13:45:35

**Appendix F**  
**CY 2003 RLWTF Feed VOC Results by Species**

**RADIOACTIVE LIQUID WASTE TREATMENT FACILITY**

VOC results by species for TA50 Plant Feed  
JAN-2003 through DEC-2003

Sample Date	Sample Number	Species	Concentration (mg/L)	Uncertainty (mg/L)
10-Nov-03	P1103.10	1,2,3-TRICHLOROBENZENE	2.6 E-3	260. E-6
6-Jan-03	P0103.06	1,2,4-TRIMETHYLBENZENE	11. E-3	1. E-3
28-May-03	P0503.28	1,2,4-TRIMETHYLBENZENE	2. E-3	230. E-6
2-Jun-03	P0603.02	1,2,4-TRIMETHYLBENZENE	1. E-3	110. E-6
9-Jun-03	P0603.09	1,2,4-TRIMETHYLBENZENE	2. E-3	150. E-6
16-Jun-03	P0603.16	1,2,4-TRIMETHYLBENZENE	1. E-3	120. E-6
23-Jun-03	P0603.23	1,2,4-TRIMETHYLBENZENE	2. E-3	200. E-6
1-Jul-03	P0703.01	1,2,4-TRIMETHYLBENZENE	1. E-3	120. E-6
14-Jul-03	P0703.14	1,2,4-TRIMETHYLBENZENE	870. E-6	87. E-6
28-Jul-03	P0703.28	1,2,4-TRIMETHYLBENZENE	1.1 E-3	110. E-6
18-Aug-03	P0803.18	1,2,4-TRIMETHYLBENZENE	1.3 E-3	130. E-6
20-Oct-03	P1003.20	1,2,4-TRIMETHYLBENZENE	4.4 E-3	440. E-6
3-Nov-03	P1103.03	1,2,4-TRIMETHYLBENZENE	3.1 E-3	310. E-6
10-Nov-03	P1103.10	1,2,4-TRIMETHYLBENZENE	2.8 E-3	280. E-6
24-Nov-03	P1103.24	1,2,4-TRIMETHYLBENZENE	880. E-6	88. E-6
17-Dec-03	P1203.17	1,2,4-TRIMETHYLBENZENE	840. E-6	84. E-6
8-Apr-03	P0403.08	1,2-DICHLOROBENZENE	1. E-3	130. E-6
8-Apr-03	P0403.08	1,2-DICHLOROETHANE	490. E-6	49. E-6
2-Dec-03	P1203.02	1,2-DICHLOROETHANE	30. E-3	3. E-3
6-Jan-03	P0103.06	1,2-XYLENE	3. E-3	310. E-6
18-Aug-03	P0803.18	1,2-XYLENE	510. E-6	51. E-6
2-Dec-03	P1203.02	1,2-XYLENE	1.4 E-3	140. E-6
10-Nov-03	P1103.10	1,3,5-TRIMETHYLBENZENE	650. E-6	65. E-6
6-Jan-03	P0103.06	1,3-XYLENE+XYLENE[1,4-]	10. E-3	980. E-6
16-Jun-03	P0603.16	1,3-XYLENE+XYLENE[1,4-]	1. E-3	100. E-6
18-Feb-03	P0203.18	2-BUTANONE	7. E-3	670. E-6
5-May-03	P0503.05	2-BUTANONE	12. E-3	1. E-3
25-Aug-03	P0803.25	2-BUTANONE	15. E-3	1.5 E-3
15-Oct-03	P1003.15	2-BUTANONE	14. E-3	1.4 E-3
17-Dec-03	P1203.17	2-BUTANONE	7.7 E-3	770. E-6
10-Nov-03	P1103.10	4-ISOPROPYLTOLUENE	890. E-6	89. E-6
8-Apr-03	P0403.08	4-METHYL-2-PENTANONE	3. E-3	320. E-6
14-Jul-03	P0703.14	4-METHYL-2-PENTANONE	24. E-3	2.4 E-3
8-Sep-03	P0903.08	4-METHYL-2-PENTANONE	4. E-3	400. E-6
22-Sep-03	P0903.22	4-METHYL-2-PENTANONE	8.9 E-3	890. E-6
29-Sep-03	P0903.29	4-METHYL-2-PENTANONE	2.4 E-3	240. E-6
15-Oct-03	P1003.15	4-METHYL-2-PENTANONE	130. E-3	13. E-3
20-Oct-03	P1003.20	4-METHYL-2-PENTANONE	35. E-3	3.5 E-3
27-Oct-03	P1003.27	4-METHYL-2-PENTANONE	100. E-3	10. E-3
3-Nov-03	P1103.03	4-METHYL-2-PENTANONE	39. E-3	3.9 E-3
10-Nov-03	P1103.10	4-METHYL-2-PENTANONE	22. E-3	2.2 E-3
17-Nov-03	P1103.17	4-METHYL-2-PENTANONE	12. E-3	1.2 E-3
24-Nov-03	P1103.24	4-METHYL-2-PENTANONE	16. E-3	1.6 E-3

VOC results by species for TA50 Plant Feed				Page 2 of 5	
Sample Date	Sample Number	Species	Concentration (mg/L)	Uncertainty (mg/L)	
2-Dec-03	P1203.02	4-METHYL-2-PENTANONE	150. E-3	15. E-3	
8-Dec-03	P1203.08	4-METHYL-2-PENTANONE	340. E-3	34. E-3	
17-Dec-03	P1203.17	4-METHYL-2-PENTANONE	140. E-3	14. E-3	
22-Dec-03	P1203.22	4-METHYL-2-PENTANONE	120. E-3	12. E-3	
6-Jan-03	P0103.06	ACETONE	87. E-3	9. E-3	
14-Jan-03	P0103.14	ACETONE	760. E-3	76. E-3	
21-Jan-03	P0103.21	ACETONE	380. E-3	38. E-3	
28-Jan-03	P0103.28	ACETONE	210. E-3	21. E-3	
3-Feb-03	P0203.03	ACETONE	120. E-3	12. E-3	
11-Feb-03	P0203.11	ACETONE	3.1 E0	310. E-3	
18-Feb-03	P0203.18	ACETONE	1.4 E0	140. E-3	
24-Feb-03	P0203.24	ACETONE	640. E-3	64. E-3	
3-Mar-03	P0303.03	ACETONE	440. E-3	44. E-3	
10-Mar-03	P0303.10	ACETONE	630. E-3	63. E-3	
17-Mar-03	P0303.17	ACETONE	610. E-3	61. E-3	
24-Mar-03	P0303.24	ACETONE	300. E-3	30. E-3	
31-Mar-03	P0303.31	ACETONE	240. E-3	24. E-3	
8-Apr-03	P0403.08	ACETONE	560. E-3	56. E-3	
14-Apr-03	P0403.14	ACETONE	560. E-3	56. E-3	
1-May-03	P0503.01	ACETONE	1.6 E0	160. E-3	
5-May-03	P0503.05	ACETONE	560. E-3	56. E-3	
12-May-03	P0503.12	ACETONE	78. E-3	8. E-3	
20-May-03	P0503.20	ACETONE	370. E-3	37. E-3	
28-May-03	P0503.28	ACETONE	460. E-3	46. E-3	
2-Jun-03	P0603.02	ACETONE	540. E-3	54. E-3	
9-Jun-03	P0603.09	ACETONE	250. E-3	25. E-3	
16-Jun-03	P0603.16	ACETONE	510. E-3	51. E-3	
23-Jun-03	P0603.23	ACETONE	360. E-3	36. E-3	
1-Jul-03	P0703.01	ACETONE	800. E-3	80. E-3	
7-Jul-03	P0703.07	ACETONE	500. E-3	50. E-3	
14-Jul-03	P0703.14	ACETONE	510. E-3	51. E-3	
21-Jul-03	P0703.21	ACETONE	710. E-3	71. E-3	
28-Jul-03	P0703.28	ACETONE	500. E-3	50. E-3	
4-Aug-03	P0803.04	ACETONE	390. E-3	39. E-3	
12-Aug-03	P0803.12	ACETONE	330. E-3	33. E-3	
18-Aug-03	P0803.18	ACETONE	290. E-3	29. E-3	
25-Aug-03	P0803.25	ACETONE	220. E-3	22. E-3	
2-Sep-03	P0903.02	ACETONE	320. E-3	32. E-3	
8-Sep-03	P0903.08	ACETONE	420. E-3	42. E-3	
15-Sep-03	P0903.15	ACETONE	590. E-3	59. E-3	
22-Sep-03	P0903.22	ACETONE	560. E-3	56. E-3	
29-Sep-03	P0903.29	ACETONE	400. E-3	40. E-3	
15-Oct-03	P1003.15	ACETONE	440. E-3	44. E-3	
20-Oct-03	P1003.20	ACETONE	170. E-3	17. E-3	
27-Oct-03	P1003.27	ACETONE	220. E-3	22. E-3	
3-Nov-03	P1103.03	ACETONE	80. E-3	8. E-3	

VOC results by species for TA50 Plant Feed				Page 3 of 5	
Sample Date	Sample Number	Species	Concentration (mg/L)	Uncertainty (mg/L)	
10-Nov-03	P1103.10	ACETONE	500. E-3	50. E-3	
17-Nov-03	P1103.17	ACETONE	280. E-3	28. E-3	
24-Nov-03	P1103.24	ACETONE	530. E-3	53. E-3	
2-Dec-03	P1203.02	ACETONE	290. E-3	29. E-3	
8-Dec-03	P1203.08	ACETONE	240. E-3	24. E-3	
17-Dec-03	P1203.17	ACETONE	620. E-3	62. E-3	
22-Dec-03	P1203.22	ACETONE	720. E-3	72. E-3	
18-Aug-03	P0803.18	BROMOBENZENE	890. E-6	89. E-6	
25-Aug-03	P0803.25	BROMOBENZENE	820. E-6	82. E-6	
22-Sep-03	P0903.22	BROMOBENZENE	1.7 E-3	170. E-6	
2-Dec-03	P1203.02	BROMOMETHANE	3.5 E-3	350. E-6	
6-Jan-03	P0103.06	CHLOROFORM	4. E-3	400. E-6	
28-Jan-03	P0103.28	CHLOROFORM	2. E-3	230. E-6	
24-Mar-03	P0303.24	CHLOROFORM	1. E-3	120. E-6	
31-Mar-03	P0303.31	CHLOROFORM	1. E-3	100. E-6	
8-Apr-03	P0403.08	CHLOROFORM	760. E-6	76. E-6	
14-Apr-03	P0403.14	CHLOROFORM	6. E-3	610. E-6	
1-May-03	P0503.01	CHLOROFORM	770. E-6	77. E-6	
5-May-03	P0503.05	CHLOROFORM	2. E-3	150. E-6	
12-May-03	P0503.12	CHLOROFORM	610. E-6	61. E-6	
20-May-03	P0503.20	CHLOROFORM	1. E-3	110. E-6	
28-May-03	P0503.28	CHLOROFORM	430. E-6	43. E-6	
2-Jun-03	P0603.02	CHLOROFORM	400. E-6	40. E-6	
9-Jun-03	P0603.09	CHLOROFORM	670. E-6	67. E-6	
16-Jun-03	P0603.16	CHLOROFORM	1. E-3	110. E-6	
23-Jun-03	P0603.23	CHLOROFORM	2. E-3	190. E-6	
1-Jul-03	P0703.01	CHLOROFORM	2. E-3	220. E-6	
7-Jul-03	P0703.07	CHLOROFORM	2. E-3	150. E-6	
14-Jul-03	P0703.14	CHLOROFORM	1.2 E-3	120. E-6	
21-Jul-03	P0703.21	CHLOROFORM	5. E-3	500. E-6	
28-Jul-03	P0703.28	CHLOROFORM	1.3 E-3	130. E-6	
4-Aug-03	P0803.04	CHLOROFORM	740. E-6	74. E-6	
18-Aug-03	P0803.18	CHLOROFORM	360. E-6	36. E-6	
25-Aug-03	P0803.25	CHLOROFORM	490. E-6	49. E-6	
2-Sep-03	P0903.02	CHLOROFORM	1.2 E-3	120. E-6	
8-Sep-03	P0903.08	CHLOROFORM	450. E-6	45. E-6	
15-Sep-03	P0903.15	CHLOROFORM	960. E-6	96. E-6	
22-Sep-03	P0903.22	CHLOROFORM	1.2 E-3	120. E-6	
29-Sep-03	P0903.29	CHLOROFORM	400. E-6	40. E-6	
15-Oct-03	P1003.15	CHLOROFORM	1.1 E-3	110. E-6	
20-Oct-03	P1003.20	CHLOROFORM	1.7 E-3	170. E-6	
27-Oct-03	P1003.27	CHLOROFORM	1.6 E-3	160. E-6	
3-Nov-03	P1103.03	CHLOROFORM	2. E-3	200. E-6	
10-Nov-03	P1103.10	CHLOROFORM	3.9 E-3	390. E-6	
17-Nov-03	P1103.17	CHLOROFORM	5.8 E-3	580. E-6	
24-Nov-03	P1103.24	CHLOROFORM	1.9 E-3	190. E-6	

VOC results by species for TA50 Plant Feed				Page 4 of 5	
Sample Date	Sample Number	Species	Concentration (mg/L)	Uncertainty (mg/L)	
2-Dec-03	P1203.02	CHLOROFORM	1.4 E-3	140. E-6	
8-Dec-03	P1203.08	CHLOROFORM	1. E-3	100. E-6	
17-Dec-03	P1203.17	CHLOROFORM	610. E-6	61. E-6	
22-Dec-03	P1203.22	CHLOROFORM	740. E-6	74. E-6	
9-Jun-03	P0603.09	CHLOROMETHANE	260. E-6	26. E-6	
24-Nov-03	P1103.24	CHLOROMETHANE	2. E-3	200. E-6	
2-Dec-03	P1203.02	CHLOROMETHANE	3.9 E-3	390. E-6	
17-Dec-03	P1203.17	CHLOROMETHANE	3.6 E-3	360. E-6	
2-Dec-03	P1203.02	CIS-1,2-DICHLOROETHENE	1.6 E-3	160. E-6	
2-Dec-03	P1203.02	CIS/TRANS-1,2-DICHLOROETHENE	1.6 E-3	160. E-6	
17-Dec-03	P1203.17	DI-N-OCTYL PHTHALATE	2.8 E-3	280. E-6	
6-Jan-03	P0103.06	ETHYLBENZENE	3. E-3	280. E-6	
2-Dec-03	P1203.02	ETHYLBENZENE	1. E-3	100. E-6	
10-Nov-03	P1103.10	HEXACHLOROBUTADIENE	2. E-3	200. E-6	
10-Nov-03	P1103.10	ISOPROPYLBENZENE	760. E-6	76. E-6	
3-Mar-03	P0303.03	METHYL TERT-BUTYL ETHER	76. E-3	8. E-3	
6-Jan-03	P0103.06	METHYLENE CHLORIDE	33. E-3	3. E-3	
14-Jan-03	P0103.14	METHYLENE CHLORIDE	16. E-3	2. E-3	
21-Jan-03	P0103.21	METHYLENE CHLORIDE	13. E-3	1. E-3	
28-Jan-03	P0103.28	METHYLENE CHLORIDE	28. E-3	3. E-3	
3-Feb-03	P0203.03	METHYLENE CHLORIDE	11. E-3	1. E-3	
18-Feb-03	P0203.18	METHYLENE CHLORIDE	8. E-3	830. E-6	
24-Feb-03	P0203.24	METHYLENE CHLORIDE	8. E-3	790. E-6	
3-Mar-03	P0303.03	METHYLENE CHLORIDE	17. E-3	2. E-3	
10-Mar-03	P0303.10	METHYLENE CHLORIDE	16. E-3	2. E-3	
17-Mar-03	P0303.17	METHYLENE CHLORIDE	60. E-3	6. E-3	
24-Mar-03	P0303.24	METHYLENE CHLORIDE	3. E-3	330. E-6	
31-Mar-03	P0303.31	METHYLENE CHLORIDE	5. E-3	470. E-6	
8-Apr-03	P0403.08	METHYLENE CHLORIDE	4. E-3	420. E-6	
14-Apr-03	P0403.14	METHYLENE CHLORIDE	24. E-3	2. E-3	
1-May-03	P0503.01	METHYLENE CHLORIDE	2. E-3	200. E-6	
12-May-03	P0503.12	METHYLENE CHLORIDE	8. E-3	780. E-6	
20-May-03	P0503.20	METHYLENE CHLORIDE	2. E-3	190. E-6	
28-May-03	P0503.28	METHYLENE CHLORIDE	2. E-3	250. E-6	
2-Jun-03	P0603.02	METHYLENE CHLORIDE	4. E-3	400. E-6	
9-Jun-03	P0603.09	METHYLENE CHLORIDE	790. E-6	79. E-6	
16-Jun-03	P0603.16	METHYLENE CHLORIDE	2. E-3	240. E-6	
23-Jun-03	P0603.23	METHYLENE CHLORIDE	6. E-3	610. E-6	
1-Jul-03	P0703.01	METHYLENE CHLORIDE	6. E-3	600. E-6	
7-Jul-03	P0703.07	METHYLENE CHLORIDE	8. E-3	810. E-6	
21-Jul-03	P0703.21	METHYLENE CHLORIDE	66. E-3	6.6 E-3	
28-Jul-03	P0703.28	METHYLENE CHLORIDE	3.8 E-3	380. E-6	
4-Aug-03	P0803.04	METHYLENE CHLORIDE	5.2 E-3	520. E-6	
12-Aug-03	P0803.12	METHYLENE CHLORIDE	2.7 E-3	270. E-6	
18-Aug-03	P0803.18	METHYLENE CHLORIDE	17. E-3	1.7 E-3	
25-Aug-03	P0803.25	METHYLENE CHLORIDE	4.3 E-3	430. E-6	



VOC results by species for TA50 Plant Feed				Page 5 of 5	
Sample Date	Sample Number	Species	Concentration (mg/L)	Uncertainty (mg/L)	
2-Sep-03	P0903.02	METHYLENE CHLORIDE	5.9 E-3	590. E-6	
8-Sep-03	P0903.08	METHYLENE CHLORIDE	3.6 E-3	360. E-6	
15-Sep-03	P0903.15	METHYLENE CHLORIDE	3.7 E-3	370. E-6	
22-Sep-03	P0903.22	METHYLENE CHLORIDE	6.4 E-3	640. E-6	
29-Sep-03	P0903.29	METHYLENE CHLORIDE	5.4 E-3	540. E-6	
15-Oct-03	P1003.15	METHYLENE CHLORIDE	5.7 E-3	570. E-6	
20-Oct-03	P1003.20	METHYLENE CHLORIDE	5.7 E-3	570. E-6	
27-Oct-03	P1003.27	METHYLENE CHLORIDE	5.4 E-3	540. E-6	
3-Nov-03	P1103.03	METHYLENE CHLORIDE	6.5 E-3	650. E-6	
10-Nov-03	P1103.10	METHYLENE CHLORIDE	6. E-3	600. E-6	
24-Nov-03	P1103.24	METHYLENE CHLORIDE	2.1 E-3	210. E-6	
2-Dec-03	P1203.02	METHYLENE CHLORIDE	2.8 E-3	280. E-6	
8-Dec-03	P1203.08	METHYLENE CHLORIDE	1.7 E-3	170. E-6	
17-Dec-03	P1203.17	METHYLENE CHLORIDE	3.7 E-3	370. E-6	
22-Dec-03	P1203.22	METHYLENE CHLORIDE	9.9 E-3	990. E-6	
18-Aug-03	P0803.18	N-NITROSO-DI-N-PROPYLAMINE	7.5 E-3	750. E-6	
17-Nov-03	P1103.17	N-NITROSO-DI-N-PROPYLAMINE	46. E-3	4.6 E-3	
24-Nov-03	P1103.24	N-NITROSO-DI-N-PROPYLAMINE	44. E-3	4.4 E-3	
10-Nov-03	P1103.10	SEC-BUTYLBENZENE	900. E-6	90. E-6	
18-Aug-03	P0803.18	STYRENE	640. E-6	64. E-6	
10-Nov-03	P1103.10	TERT-BUTYLBENZENE	820. E-6	82. E-6	
6-Jan-03	P0103.06	TOLUENE	14. E-3	1. E-3	
10-Nov-03	P1103.10	TOLUENE	1.2 E-3	120. E-6	
2-Dec-03	P1203.02	TOLUENE	4.4 E-3	440. E-6	
6-Jan-03	P0103.06	TRICHLOROETHENE	4. E-3	430. E-6	
6-Jan-03	P0103.06	XYLENE (TOTAL)	13. E-3	1. E-3	
18-Aug-03	P0803.18	XYLENE (TOTAL)	1.7 E-3	170. E-6	
2-Dec-03	P1203.02	XYLENE (TOTAL)	5.7 E-3	570. E-6	
18-Aug-03	P0803.18	XYLENE[1,3-]+XYLENE[1,4-]	1.2 E-3	120. E-6	
2-Dec-03	P1203.02	XYLENE[1,3-]+XYLENE[1,4-]	4.3 E-3	430. E-6	

Issued 01/27/2004 13:46:08

**Appendix G**  
**CY 2003 RLWTF Feed SVOC Results by Sample**

## RADIOACTIVE LIQUID WASTE TREATMENT FACILITY

SVOC results by sample for TA50 Plant Feed  
JAN-2003 through DEC-2003

Sample Date	Sample Number	Species	Concentration (mg/L)	Uncertainty (mg/L)
6-Jan-03	P0103.06	BENZOIC ACID	430. E-3	43. E-3
6-Jan-03	P0103.06	BENZYL ALCOHOL	210. E-3	21. E-3
14-Jan-03	P0103.14	BENZOIC ACID	71. E-3	7. E-3
14-Jan-03	P0103.14	BIS(2-ETHYLHEXYL)PHTHALATE	18. E-3	2. E-3
21-Jan-03	P0103.21	BENZOIC ACID	28. E-3	3. E-3
28-Jan-03	P0103.28	BENZOIC ACID	45. E-3	5. E-3
28-Jan-03	P0103.28	BIS(2-ETHYLHEXYL)PHTHALATE	5. E-3	500. E-6
3-Feb-03	P0203.03	BENZOIC ACID	19. E-3	2. E-3
3-Feb-03	P0203.03	PYRIDINE	17. E-3	2. E-3
11-Feb-03	P0203.11	BIS(2-ETHYLHEXYL)PHTHALATE	130. E-3	13. E-3
11-Feb-03	P0203.11	BUTYLBENZYLPHthalate	3. E-3	330. E-6
18-Feb-03	P0203.18	BENZOIC ACID	27. E-3	3. E-3
18-Feb-03	P0203.18	BIS(2-ETHYLHEXYL)PHTHALATE	9. E-3	930. E-6
24-Feb-03	P0203.24	BENZOIC ACID	42. E-3	4. E-3
24-Feb-03	P0203.24	BIS(2-ETHYLHEXYL)PHTHALATE	31. E-3	3. E-3
3-Mar-03	P0303.03	BENZOIC ACID	13. E-3	1. E-3
3-Mar-03	P0303.03	BIS(2-ETHYLHEXYL)PHTHALATE	11. E-3	1. E-3
3-Mar-03	P0303.03	DIETHYLPHthalate	9. E-3	910. E-6
10-Mar-03	P0303.10	BENZOIC ACID	6. E-3	560. E-6
10-Mar-03	P0303.10	BIS(2-ETHYLHEXYL)PHTHALATE	5. E-3	450. E-6
17-Mar-03	P0303.17	BENZOIC ACID	14. E-3	1. E-3
17-Mar-03	P0303.17	BIS(2-ETHYLHEXYL)PHTHALATE	11. E-3	1. E-3
17-Mar-03	P0303.17	N-NITROSODIMETHYLAMINE	4. E-3	370. E-6
31-Mar-03	P0303.31	BENZOIC ACID	8. E-3	800. E-6
8-Apr-03	P0403.08	PYRIDINE	10. E-3	980. E-6
14-Apr-03	P0403.14	BENZOIC ACID	47. E-3	5. E-3
14-Apr-03	P0403.14	BIS(2-ETHYLHEXYL)PHTHALATE	8. E-3	820. E-6
1-May-03	P0503.01	2-NITROPHENOL	2. E-3	250. E-6
1-May-03	P0503.01	BENZOIC ACID	37. E-3	4. E-3
1-May-03	P0503.01	BIS(2-ETHYLHEXYL)PHTHALATE	9. E-3	910. E-6
1-May-03	P0503.01	DIETHYLPHthalate	2. E-3	240. E-6
1-May-03	P0503.01	PYRIDINE	8. E-3	830. E-6
5-May-03	P0503.05	BENZOIC ACID	26. E-3	3. E-3
5-May-03	P0503.05	BIS(2-ETHYLHEXYL)PHTHALATE	13. E-3	1. E-3
5-May-03	P0503.05	DIETHYLPHthalate	3. E-3	270. E-6
12-May-03	P0503.12	BIS(2-ETHYLHEXYL)PHTHALATE	12. E-3	1. E-3
12-May-03	P0503.12	BUTYLBENZYLPHthalate	2. E-3	240. E-6
12-May-03	P0503.12	PYRIDINE	100. E-3	10. E-3
20-May-03	P0503.20	BENZOIC ACID	28. E-3	3. E-3
20-May-03	P0503.20	BIS(2-ETHYLHEXYL)PHTHALATE	18. E-3	2. E-3
20-May-03	P0503.20	DIETHYLPHthalate	4. E-3	390. E-6
20-May-03	P0503.20	PYRIDINE	71. E-3	7. E-3
28-May-03	P0503.28	3-METHYLPHENOL & 4-	2. E-3	220. E-6

SVOC results by sample for TA50 Plant Feed				Page 2 of 4	
Sample Date	Sample Number	Species	Concentration (mg/L)	Uncertainty (mg/L)	
28-May-03	P0503.28	BENZOIC ACID	85. E-3	8. E-3	
28-May-03	P0503.28	BIS(2-ETHYLHEXYL)PHTHALATE	7. E-3	740. E-6	
28-May-03	P0503.28	DIETHYLPHTHALATE	2. E-3	230. E-6	
28-May-03	P0503.28	PHENOL	7. E-3	710. E-6	
28-May-03	P0503.28	PYRIDINE	56. E-3	6. E-3	
2-Jun-03	P0603.02	BENZOIC ACID	87. E-3	9. E-3	
2-Jun-03	P0603.02	BIS(2-ETHYLHEXYL)PHTHALATE	9. E-3	890. E-6	
2-Jun-03	P0603.02	DIETHYLPHTHALATE	3. E-3	270. E-6	
2-Jun-03	P0603.02	PHENOL	4. E-3	370. E-6	
2-Jun-03	P0603.02	PYRIDINE	70. E-3	7. E-3	
9-Jun-03	P0603.09	3-METHYLPHENOL & 4-	3. E-3	320. E-6	
9-Jun-03	P0603.09	BENZOIC ACID	51. E-3	5. E-3	
9-Jun-03	P0603.09	BIS(2-ETHYLHEXYL)PHTHALATE	29. E-3	3. E-3	
9-Jun-03	P0603.09	PHENOL	370. E-3	37. E-3	
9-Jun-03	P0603.09	PYRIDINE	44. E-3	4. E-3	
16-Jun-03	P0603.16	2-NITROPHENOL	2. E-3	240. E-6	
16-Jun-03	P0603.16	BENZYL ALCOHOL	14. E-3	1. E-3	
16-Jun-03	P0603.16	BIS(2-ETHYLHEXYL)PHTHALATE	36. E-3	4. E-3	
16-Jun-03	P0603.16	DIETHYLPHTHALATE	2. E-3	210. E-6	
16-Jun-03	P0603.16	PHENOL	9. E-3	880. E-6	
23-Jun-03	P0603.23	BENZYL ALCOHOL	5. E-3	460. E-6	
23-Jun-03	P0603.23	BIS(2-ETHYLHEXYL)PHTHALATE	9. E-3	870. E-6	
23-Jun-03	P0603.23	PHENOL	2. E-3	250. E-6	
23-Jun-03	P0603.23	PYRIDINE	13. E-3	1. E-3	
1-Jul-03	P0703.01	BENZOIC ACID	15. E-3	2. E-3	
1-Jul-03	P0703.01	BENZYL ALCOHOL	2. E-3	250. E-6	
1-Jul-03	P0703.01	BIS(2-ETHYLHEXYL)PHTHALATE	8. E-3	770. E-6	
1-Jul-03	P0703.01	BUTYLBENZYLPHTHALATE	2. E-3	230. E-6	
1-Jul-03	P0703.01	PHENOL	66. E-3	7. E-3	
1-Jul-03	P0703.01	PYRIDINE	16. E-3	2. E-3	
7-Jul-03	P0703.07	BENZOIC ACID	19. E-3	2. E-3	
7-Jul-03	P0703.07	BIS(2-ETHYLHEXYL)PHTHALATE	21. E-3	2. E-3	
7-Jul-03	P0703.07	PHENOL	22. E-3	2. E-3	
7-Jul-03	P0703.07	PYRIDINE	14. E-3	1. E-3	
14-Jul-03	P0703.14	BENZOIC ACID	13. E-3	1.3 E-3	
14-Jul-03	P0703.14	BIS(2-ETHYLHEXYL)PHTHALATE	13. E-3	1.3 E-3	
14-Jul-03	P0703.14	N-NITROSO-DI-N-PROPYLAMINE	3.7 E-3	370. E-6	
14-Jul-03	P0703.14	PHENOL	3.6 E-3	360. E-6	
14-Jul-03	P0703.14	PYRIDINE	43. E-3	4.3 E-3	
21-Jul-03	P0703.21	3-METHYLPHENOL & 4-	3.3 E-3	330. E-6	
21-Jul-03	P0703.21	BIS(2-ETHYLHEXYL)PHTHALATE	11. E-3	1.1 E-3	
21-Jul-03	P0703.21	DIETHYLPHTHALATE	2.6 E-3	260. E-6	
21-Jul-03	P0703.21	PHENOL	50. E-3	5. E-3	
21-Jul-03	P0703.21	PYRIDINE	14. E-3	1.4 E-3	
28-Jul-03	P0703.28	BIS(2-ETHYLHEXYL)PHTHALATE	3. E-3	300. E-6	
28-Jul-03	P0703.28	PYRIDINE	7.5 E-3	750. E-6	

SVOC results by sample for TA50 Plant Feed				Page 3 of 4	
Sample Date	Sample Number	Species	Concentration (mg/L)	Uncertainty (mg/L)	
4-Aug-03	P0803.04	BIS(2-ETHYLHEXYL)PHTHALATE	24. E-3	2.4 E-3	
4-Aug-03	P0803.04	PYRIDINE	5.5 E-3	550. E-6	
12-Aug-03	P0803.12	BENZOIC ACID	2.7 E-3	270. E-6	
12-Aug-03	P0803.12	BIS(2-ETHYLHEXYL)PHTHALATE	7.6 E-3	760. E-6	
12-Aug-03	P0803.12	N-NITROSO-DI-N-PROPYLAMINE	20. E-3	2. E-3	
18-Aug-03	P0803.18	BIS(2-ETHYLHEXYL)PHTHALATE	5.1 E-3	510. E-6	
25-Aug-03	P0803.25	BENZOIC ACID	31. E-3	3.1 E-3	
25-Aug-03	P0803.25	BIS(2-ETHYLHEXYL)PHTHALATE	4.8 E-3	480. E-6	
25-Aug-03	P0803.25	PYRIDINE	21. E-3	2.1 E-3	
2-Sep-03	P0903.02	BENZYL ALCOHOL	2.3 E-3	230. E-6	
2-Sep-03	P0903.02	BIS(2-ETHYLHEXYL)PHTHALATE	33. E-3	3.3 E-3	
2-Sep-03	P0903.02	PYRIDINE	5.1 E-3	510. E-6	
8-Sep-03	P0903.08	BIS(2-ETHYLHEXYL)PHTHALATE	6.9 E-3	690. E-6	
8-Sep-03	P0903.08	DIETHYLPHTHALATE	2.5 E-3	250. E-6	
15-Sep-03	P0903.15	BENZOIC ACID	6.8 E-3	680. E-6	
15-Sep-03	P0903.15	BIS(2-ETHYLHEXYL)PHTHALATE	4.4 E-3	440. E-6	
15-Sep-03	P0903.15	DIETHYLPHTHALATE	5.1 E-3	510. E-6	
22-Sep-03	P0903.22	BENZOIC ACID	59. E-3	5.9 E-3	
22-Sep-03	P0903.22	BIS(2-ETHYLHEXYL)PHTHALATE	6.8 E-3	680. E-6	
29-Sep-03	P0903.29	BENZOIC ACID	68. E-3	6.8 E-3	
29-Sep-03	P0903.29	BIS(2-ETHYLHEXYL)PHTHALATE	11. E-3	1.1 E-3	
29-Sep-03	P0903.29	DIETHYLPHTHALATE	7.8 E-3	780. E-6	
29-Sep-03	P0903.29	PHENOL	2.9 E-3	290. E-6	
15-Oct-03	P1003.15	BENZYL ALCOHOL	4.4 E-3	440. E-6	
15-Oct-03	P1003.15	BIS(2-ETHYLHEXYL)PHTHALATE	9.1 E-3	910. E-6	
15-Oct-03	P1003.15	DIETHYLPHTHALATE	3.1 E-3	310. E-6	
20-Oct-03	P1003.20	BENZOIC ACID	73. E-3	7.3 E-3	
20-Oct-03	P1003.20	BIS(2-ETHYLHEXYL)PHTHALATE	5.4 E-3	540. E-6	
20-Oct-03	P1003.20	PHENOL	190. E-3	19. E-3	
27-Oct-03	P1003.27	BENZOIC ACID	66. E-3	6.6 E-3	
27-Oct-03	P1003.27	PHENOL	6.2 E-3	620. E-6	
27-Oct-03	P1003.27	PYRIDINE	39. E-3	3.9 E-3	
3-Nov-03	P1103.03	BENZOIC ACID	70. E-3	7. E-3	
3-Nov-03	P1103.03	BIS(2-ETHYLHEXYL)PHTHALATE	2.8 E-3	280. E-6	
3-Nov-03	P1103.03	PYRIDINE	13. E-3	1.3 E-3	
10-Nov-03	P1103.10	BIS(2-ETHYLHEXYL)PHTHALATE	4.2 E-3	420. E-6	
10-Nov-03	P1103.10	PYRIDINE	7.3 E-3	730. E-6	
24-Nov-03	P1103.24	BIS(2-ETHYLHEXYL)PHTHALATE	22. E-3	2.2 E-3	
24-Nov-03	P1103.24	DI-N-BUTYLPHTHALATE	3. E-3	300. E-6	
2-Dec-03	P1203.02	BIS(2-ETHYLHEXYL)PHTHALATE	3.6 E-3	360. E-6	
2-Dec-03	P1203.02	PYRIDINE	6.3 E-3	630. E-6	
8-Dec-03	P1203.08	BENZYL ALCOHOL	3.9 E-3	390. E-6	
8-Dec-03	P1203.08	BIS(2-ETHYLHEXYL)PHTHALATE	10. E-3	1. E-3	
17-Dec-03	P1203.17	2-NITROPHENOL	3.3 E-3	330. E-6	
17-Dec-03	P1203.17	BENZOIC ACID	47. E-3	4.7 E-3	
17-Dec-03	P1203.17	BIS(2-ETHYLHEXYL)PHTHALATE	86. E-3	8.6 E-3	



**Appendix H**  
**CY 2003 RLWTF Feed SVOC Results by Species**

## RADIOACTIVE LIQUID WASTE TREATMENT FACILITY

SVOC results by species for TA50 Plant Feed

JAN-2003 through DEC-2003

Sample Date	Sample Number	Species	Concentration (mg/L)	Uncertainty (mg/L)
1-May-03	P0503.01	2-NITROPHENOL	2. E-3	250. E-6
16-Jun-03	P0603.16	2-NITROPHENOL	2. E-3	240. E-6
17-Dec-03	P1203.17	2-NITROPHENOL	3.3 E-3	330. E-6
28-May-03	P0503.28	3-METHYLPHENOL & 4-METHYLPHENOL	2. E-3	220. E-6
9-Jun-03	P0603.09	3-METHYLPHENOL & 4-METHYLPHENOL	3. E-3	320. E-6
21-Jul-03	P0703.21	3-METHYLPHENOL & 4-METHYLPHENOL	3.3 E-3	330. E-6
6-Jan-03	P0103.06	BENZOIC ACID	430. E-3	43. E-3
14-Jan-03	P0103.14	BENZOIC ACID	71. E-3	7. E-3
21-Jan-03	P0103.21	BENZOIC ACID	28. E-3	3. E-3
28-Jan-03	P0103.28	BENZOIC ACID	45. E-3	5. E-3
3-Feb-03	P0203.03	BENZOIC ACID	19. E-3	2. E-3
18-Feb-03	P0203.18	BENZOIC ACID	27. E-3	3. E-3
24-Feb-03	P0203.24	BENZOIC ACID	42. E-3	4. E-3
3-Mar-03	P0303.03	BENZOIC ACID	13. E-3	1. E-3
10-Mar-03	P0303.10	BENZOIC ACID	6. E-3	560. E-6
17-Mar-03	P0303.17	BENZOIC ACID	14. E-3	1. E-3
31-Mar-03	P0303.31	BENZOIC ACID	8. E-3	800. E-6
14-Apr-03	P0403.14	BENZOIC ACID	47. E-3	5. E-3
1-May-03	P0503.01	BENZOIC ACID	37. E-3	4. E-3
5-May-03	P0503.05	BENZOIC ACID	26. E-3	3. E-3
20-May-03	P0503.20	BENZOIC ACID	28. E-3	3. E-3
28-May-03	P0503.28	BENZOIC ACID	85. E-3	8. E-3
2-Jun-03	P0603.02	BENZOIC ACID	87. E-3	9. E-3
9-Jun-03	P0603.09	BENZOIC ACID	51. E-3	5. E-3
1-Jul-03	P0703.01	BENZOIC ACID	15. E-3	2. E-3
7-Jul-03	P0703.07	BENZOIC ACID	19. E-3	2. E-3
14-Jul-03	P0703.14	BENZOIC ACID	13. E-3	1.3 E-3
12-Aug-03	P0803.12	BENZOIC ACID	2.7 E-3	270. E-6
25-Aug-03	P0803.25	BENZOIC ACID	31. E-3	3.1 E-3
15-Sep-03	P0903.15	BENZOIC ACID	6.8 E-3	680. E-6
22-Sep-03	P0903.22	BENZOIC ACID	59. E-3	5.9 E-3
29-Sep-03	P0903.29	BENZOIC ACID	68. E-3	6.8 E-3
20-Oct-03	P1003.20	BENZOIC ACID	73. E-3	7.3 E-3
27-Oct-03	P1003.27	BENZOIC ACID	66. E-3	6.6 E-3
3-Nov-03	P1103.03	BENZOIC ACID	70. E-3	7. E-3
17-Dec-03	P1203.17	BENZOIC ACID	47. E-3	4.7 E-3
22-Dec-03	P1203.22	BENZOIC ACID	29. E-3	2.9 E-3
6-Jan-03	P0103.06	BENZYL ALCOHOL	210. E-3	21. E-3
16-Jun-03	P0603.16	BENZYL ALCOHOL	14. E-3	1. E-3
23-Jun-03	P0603.23	BENZYL ALCOHOL	5. E-3	460. E-6
1-Jul-03	P0703.01	BENZYL ALCOHOL	2. E-3	250. E-6
2-Sep-03	P0903.02	BENZYL ALCOHOL	2.3 E-3	230. E-6
15-Oct-03	P1003.15	BENZYL ALCOHOL	4.4 E-3	440. E-6



SVOC results by species for TA50 Plant Feed				Page 2 of 4	
Sample Date	Sample Number	Species	Concentration (mg/L)	Uncertainty (mg/L)	
8-Dec-03	P1203.08	BENZYL ALCOHOL	3.9 E-3	390. E-6	
14-Jan-03	P0103.14	BIS(2-ETHYLHEXYL)PHTHALATE	18. E-3	2. E-3	
28-Jan-03	P0103.28	BIS(2-ETHYLHEXYL)PHTHALATE	5. E-3	500. E-6	
11-Feb-03	P0203.11	BIS(2-ETHYLHEXYL)PHTHALATE	130. E-3	13. E-3	
18-Feb-03	P0203.18	BIS(2-ETHYLHEXYL)PHTHALATE	9. E-3	930. E-6	
24-Feb-03	P0203.24	BIS(2-ETHYLHEXYL)PHTHALATE	31. E-3	3. E-3	
3-Mar-03	P0303.03	BIS(2-ETHYLHEXYL)PHTHALATE	11. E-3	1. E-3	
10-Mar-03	P0303.10	BIS(2-ETHYLHEXYL)PHTHALATE	5. E-3	450. E-6	
17-Mar-03	P0303.17	BIS(2-ETHYLHEXYL)PHTHALATE	11. E-3	1. E-3	
14-Apr-03	P0403.14	BIS(2-ETHYLHEXYL)PHTHALATE	8. E-3	820. E-6	
1-May-03	P0503.01	BIS(2-ETHYLHEXYL)PHTHALATE	9. E-3	910. E-6	
5-May-03	P0503.05	BIS(2-ETHYLHEXYL)PHTHALATE	13. E-3	1. E-3	
12-May-03	P0503.12	BIS(2-ETHYLHEXYL)PHTHALATE	12. E-3	1. E-3	
20-May-03	P0503.20	BIS(2-ETHYLHEXYL)PHTHALATE	18. E-3	2. E-3	
28-May-03	P0503.28	BIS(2-ETHYLHEXYL)PHTHALATE	7. E-3	740. E-6	
2-Jun-03	P0603.02	BIS(2-ETHYLHEXYL)PHTHALATE	9. E-3	890. E-6	
9-Jun-03	P0603.09	BIS(2-ETHYLHEXYL)PHTHALATE	29. E-3	3. E-3	
16-Jun-03	P0603.16	BIS(2-ETHYLHEXYL)PHTHALATE	36. E-3	4. E-3	
23-Jun-03	P0603.23	BIS(2-ETHYLHEXYL)PHTHALATE	9. E-3	870. E-6	
1-Jul-03	P0703.01	BIS(2-ETHYLHEXYL)PHTHALATE	8. E-3	770. E-6	
7-Jul-03	P0703.07	BIS(2-ETHYLHEXYL)PHTHALATE	21. E-3	2. E-3	
14-Jul-03	P0703.14	BIS(2-ETHYLHEXYL)PHTHALATE	13. E-3	1.3 E-3	
21-Jul-03	P0703.21	BIS(2-ETHYLHEXYL)PHTHALATE	11. E-3	1.1 E-3	
28-Jul-03	P0703.28	BIS(2-ETHYLHEXYL)PHTHALATE	3. E-3	300. E-6	
4-Aug-03	P0803.04	BIS(2-ETHYLHEXYL)PHTHALATE	24. E-3	2.4 E-3	
12-Aug-03	P0803.12	BIS(2-ETHYLHEXYL)PHTHALATE	7.6 E-3	760. E-6	
18-Aug-03	P0803.18	BIS(2-ETHYLHEXYL)PHTHALATE	5.1 E-3	510. E-6	
25-Aug-03	P0803.25	BIS(2-ETHYLHEXYL)PHTHALATE	4.8 E-3	480. E-6	
2-Sep-03	P0903.02	BIS(2-ETHYLHEXYL)PHTHALATE	33. E-3	3.3 E-3	
8-Sep-03	P0903.08	BIS(2-ETHYLHEXYL)PHTHALATE	6.9 E-3	690. E-6	
15-Sep-03	P0903.15	BIS(2-ETHYLHEXYL)PHTHALATE	4.4 E-3	440. E-6	
22-Sep-03	P0903.22	BIS(2-ETHYLHEXYL)PHTHALATE	6.8 E-3	680. E-6	
29-Sep-03	P0903.29	BIS(2-ETHYLHEXYL)PHTHALATE	11. E-3	1.1 E-3	
15-Oct-03	P1003.15	BIS(2-ETHYLHEXYL)PHTHALATE	9.1 E-3	910. E-6	
20-Oct-03	P1003.20	BIS(2-ETHYLHEXYL)PHTHALATE	5.4 E-3	540. E-6	
3-Nov-03	P1103.03	BIS(2-ETHYLHEXYL)PHTHALATE	2.8 E-3	280. E-6	
10-Nov-03	P1103.10	BIS(2-ETHYLHEXYL)PHTHALATE	4.2 E-3	420. E-6	
24-Nov-03	P1103.24	BIS(2-ETHYLHEXYL)PHTHALATE	22. E-3	2.2 E-3	
2-Dec-03	P1203.02	BIS(2-ETHYLHEXYL)PHTHALATE	3.6 E-3	360. E-6	
8-Dec-03	P1203.08	BIS(2-ETHYLHEXYL)PHTHALATE	10. E-3	1. E-3	
17-Dec-03	P1203.17	BIS(2-ETHYLHEXYL)PHTHALATE	86. E-3	8.6 E-3	
22-Dec-03	P1203.22	BIS(2-ETHYLHEXYL)PHTHALATE	6. E-3	600. E-6	
11-Feb-03	P0203.11	BUTYLBENZYLPHthalate	3. E-3	330. E-6	
12-May-03	P0503.12	BUTYLBENZYLPHthalate	2. E-3	240. E-6	
1-Jul-03	P0703.01	BUTYLBENZYLPHthalate	2. E-3	230. E-6	
24-Nov-03	P1103.24	DI-N-BUTYLPHthalate	3. E-3	300. E-6	

SVOC results by species for TA50 Plant Feed				Page 3 of 4	
Sample Date	Sample Number	Species	Concentration (mg/L)	Uncertainty (mg/L)	
3-Mar-03	P0303.03	DIETHYLPHthalate	9. E-3	910. E-6	
1-May-03	P0503.01	DIETHYLPHthalate	2. E-3	240. E-6	
5-May-03	P0503.05	DIETHYLPHthalate	3. E-3	270. E-6	
20-May-03	P0503.20	DIETHYLPHthalate	4. E-3	390. E-6	
28-May-03	P0503.28	DIETHYLPHthalate	2. E-3	230. E-6	
2-Jun-03	P0603.02	DIETHYLPHthalate	3. E-3	270. E-6	
16-Jun-03	P0603.16	DIETHYLPHthalate	2. E-3	210. E-6	
21-Jul-03	P0703.21	DIETHYLPHthalate	2.6 E-3	260. E-6	
8-Sep-03	P0903.08	DIETHYLPHthalate	2.5 E-3	250. E-6	
15-Sep-03	P0903.15	DIETHYLPHthalate	5.1 E-3	510. E-6	
29-Sep-03	P0903.29	DIETHYLPHthalate	7.8 E-3	780. E-6	
15-Oct-03	P1003.15	DIETHYLPHthalate	3.1 E-3	310. E-6	
14-Jul-03	P0703.14	N-NITROSO-DI-N-PROPYLAMINE	3.7 E-3	370. E-6	
12-Aug-03	P0803.12	N-NITROSO-DI-N-PROPYLAMINE	20. E-3	2. E-3	
17-Dec-03	P1203.17	N-NITROSO-DI-N-PROPYLAMINE	54. E-3	5.4 E-3	
17-Mar-03	P0303.17	N-NITROSODIMETHYLAMINE	4. E-3	370. E-6	
28-May-03	P0503.28	PHENOL	7. E-3	710. E-6	
2-Jun-03	P0603.02	PHENOL	4. E-3	370. E-6	
9-Jun-03	P0603.09	PHENOL	370. E-3	37. E-3	
16-Jun-03	P0603.16	PHENOL	9. E-3	880. E-6	
23-Jun-03	P0603.23	PHENOL	2. E-3	250. E-6	
1-Jul-03	P0703.01	PHENOL	66. E-3	7. E-3	
7-Jul-03	P0703.07	PHENOL	22. E-3	2. E-3	
14-Jul-03	P0703.14	PHENOL	3.6 E-3	360. E-6	
21-Jul-03	P0703.21	PHENOL	50. E-3	5. E-3	
29-Sep-03	P0903.29	PHENOL	2.9 E-3	290. E-6	
20-Oct-03	P1003.20	PHENOL	190. E-3	19. E-3	
27-Oct-03	P1003.27	PHENOL	6.2 E-3	620. E-6	
17-Dec-03	P1203.17	PHENOL	2.5 E-3	250. E-6	
3-Feb-03	P0203.03	PYRIDINE	17. E-3	2. E-3	
8-Apr-03	P0403.08	PYRIDINE	10. E-3	980. E-6	
1-May-03	P0503.01	PYRIDINE	8. E-3	830. E-6	
12-May-03	P0503.12	PYRIDINE	100. E-3	10. E-3	
20-May-03	P0503.20	PYRIDINE	71. E-3	7. E-3	
28-May-03	P0503.28	PYRIDINE	56. E-3	6. E-3	
2-Jun-03	P0603.02	PYRIDINE	70. E-3	7. E-3	
9-Jun-03	P0603.09	PYRIDINE	44. E-3	4. E-3	
23-Jun-03	P0603.23	PYRIDINE	13. E-3	1. E-3	
1-Jul-03	P0703.01	PYRIDINE	16. E-3	2. E-3	
7-Jul-03	P0703.07	PYRIDINE	14. E-3	1. E-3	
14-Jul-03	P0703.14	PYRIDINE	43. E-3	4.3 E-3	
21-Jul-03	P0703.21	PYRIDINE	14. E-3	1.4 E-3	
28-Jul-03	P0703.28	PYRIDINE	7.5 E-3	750. E-6	
4-Aug-03	P0803.04	PYRIDINE	5.5 E-3	550. E-6	
25-Aug-03	P0803.25	PYRIDINE	21. E-3	2.1 E-3	
2-Sep-03	P0903.02	PYRIDINE	5.1 E-3	510. E-6	

SVOC results by species for TA50 Plant Feed			Page 4 of 4	
Sample Date	Sample Number	Species	Concentration (mg/L)	Uncertainty (mg/L)
27-Oct-03	P1003.27	PYRIDINE	39. E-3	3.9 E-3
3-Nov-03	P1103.03	PYRIDINE	13. E-3	1.3 E-3
10-Nov-03	P1103.10	PYRIDINE	7.3 E-3	730. E-6
2-Dec-03	P1203.02	PYRIDINE	6.3 E-3	630. E-6

Issued 01/27/2004 13:47:11

**Appendix I**  
**CY 2003 RLWTF Sludge VOC Results by Sample**

## RADIOACTIVE LIQUID WASTE TREATMENT FACILITY

VOC results by sample for TA50 Plant Sludge  
JAN-2003 through DEC-2003

Sample Date	Sample Number	Species	Concentration (mg/L)	Uncertainty (mg/L)
24-Feb-03	50S0203.24	1,2,4-TRIMETHYLBENZENE	14. E-3	1. E-3
24-Feb-03	50S0203.24	ACETONE	500. E-3	50. E-3
24-Feb-03	50S0203.24	DICHLORODIFLUOROMETHANE	6. E-3	560. E-6
24-Feb-03	50S0203.24	METHYLENE CHLORIDE	32. E-3	3. E-3
24-Feb-03	50S0203.24	TOLUENE	5. E-3	450. E-6
12-Mar-03	50S0303.12	1,2,4-TRIMETHYLBENZENE	8. E-3	850. E-6
12-Mar-03	50S0303.12	1,2-DICHLOROBENZENE	2. E-3	210. E-6
12-Mar-03	50S0303.12	1,3,5-TRIMETHYLBENZENE	4. E-3	420. E-6
12-Mar-03	50S0303.12	1,3-DICHLOROBENZENE	2. E-3	180. E-6
12-Mar-03	50S0303.12	1,4-DICHLOROBENZENE	2. E-3	160. E-6
12-Mar-03	50S0303.12	4-ISOPROPYLTOLUENE	2. E-3	200. E-6
12-Mar-03	50S0303.12	ACETONE	21. E-3	2. E-3
12-Mar-03	50S0303.12	DI-N-OCTYL PHTHALATE	1.2 E0	120. E-3
12-Mar-03	50S0303.12	ETHYLBENZENE	6. E-3	560. E-6
12-Mar-03	50S0303.12	METHYLENE CHLORIDE	25. E-3	2. E-3
12-Mar-03	50S0303.12	SEC-BUTYLBENZENE	2. E-3	160. E-6
12-Mar-03	50S0303.12	TETRACHLOROETHENE	6. E-3	590. E-6
12-Mar-03	50S0303.12	TOLUENE	6. E-3	610. E-6
12-Mar-03	50S0303.12	XYLENE (TOTAL)	25. E-3	2. E-3
10-Apr-03	50S0403.10	1,1,2-TRICHLORO-1,2,2-TRIFLUORO	1. E-3	140. E-6
10-Apr-03	50S0403.10	1,2,4-TRIMETHYLBENZENE	24. E-3	2. E-3
10-Apr-03	50S0403.10	1,3,5-TRIMETHYLBENZENE	4. E-3	360. E-6
10-Apr-03	50S0403.10	ACETONE	670. E-3	67. E-3
10-Apr-03	50S0403.10	ETHYLBENZENE	3. E-3	300. E-6
10-Apr-03	50S0403.10	METHYLENE CHLORIDE	19. E-3	2. E-3
10-Apr-03	50S0403.10	TETRACHLOROETHENE	17. E-3	2. E-3
10-Apr-03	50S0403.10	TOLUENE	7. E-3	650. E-6
10-Apr-03	50S0403.10	XYLENE (TOTAL)	14. E-3	1. E-3
4-Jun-03	50S0603.04	1,2,4-TRIMETHYLBENZENE	17. E-3	2. E-3
4-Jun-03	50S0603.04	2-BUTANONE	24. E-3	2. E-3
4-Jun-03	50S0603.04	ACETONE	470. E-3	47. E-3
4-Jun-03	50S0603.04	DI-N-OCTYL PHTHALATE	1.7 E0	170. E-3
4-Jun-03	50S0603.04	METHYLENE CHLORIDE	14. E-3	1. E-3
4-Jun-03	50S0603.04	TOLUENE	7. E-3	720. E-6
4-Jun-03	50S0603.04	XYLENE (TOTAL)	6. E-3	570. E-6
24-Jun-03	50S0603.24	1,2,4-TRIMETHYLBENZENE	8. E-3	800. E-6
24-Jun-03	50S0603.24	ACETONE	300. E-3	30. E-3
24-Jun-03	50S0603.24	CARBON DISULFIDE	4. E-3	430. E-6
24-Jun-03	50S0603.24	METHYLENE CHLORIDE	69. E-3	7. E-3
24-Jun-03	50S0603.24	TOLUENE	2. E-3	190. E-6
23-Jul-03	50S0703.23	1,1,2-TRICHLORO-1,2,2-TRIFLUOROETHANE	4.5 E-3	450. E-6
23-Jul-03	50S0703.23	1,2,4-TRIMETHYLBENZENE	16. E-3	1.6 E-3
23-Jul-03	50S0703.23	2-BUTANONE	270. E-3	27. E-3

VOC results by sample for TA50 Plant Sludge				Page 2 of 2	
Sample Date	Sample Number	Species	Concentration (mg/L)	Uncertainty (mg/L)	
23-Jul-03	50S0703.23	4-METHYL-2-PENTANONE	3.8 E-3	380. E-6	
23-Jul-03	50S0703.23	ACETONE	820. E-3	82. E-3	
23-Jul-03	50S0703.23	CARBON DISULFIDE	18. E-3	1.8 E-3	
23-Jul-03	50S0703.23	ETHYLBENZENE	1.3 E-3	130. E-6	
23-Jul-03	50S0703.23	METHYLENE CHLORIDE	8.6 E-3	860. E-6	
23-Jul-03	50S0703.23	STYRENE	630. E-6	63. E-6	
23-Jul-03	50S0703.23	TOLUENE	4.4 E-3	440. E-6	
23-Jul-03	50S0703.23	XYLENE (TOTAL)	6.5 E-3	650. E-6	
21-Oct-03	50S1003.21	1,2,4-TRIMETHYLBENZENE	48. E-3	4.8 E-3	
21-Oct-03	50S1003.21	ACETONE	36. E-3	3.6 E-3	
21-Oct-03	50S1003.21	CARBON DISULFIDE	5.3 E-3	530. E-6	
21-Oct-03	50S1003.21	ETHYLBENZENE	1.4 E-3	140. E-6	
21-Oct-03	50S1003.21	TETRACHLOROETHENE	15. E-3	1.5 E-3	
21-Oct-03	50S1003.21	TOLUENE	3.3 E-3	330. E-6	
21-Oct-03	50S1003.21	XYLENE (TOTAL)	4.3 E-3	430. E-6	
17-Nov-03	50S1103.17	1,2,4-TRIMETHYLBENZENE	7.9 E-3	790. E-6	
17-Nov-03	50S1103.17	CARBON DISULFIDE	4.4 E-3	440. E-6	
17-Nov-03	50S1103.17	TETRACHLOROETHENE	1.3 E-3	130. E-6	
17-Nov-03	50S1103.17	TOLUENE	3. E-3	300. E-6	
17-Nov-03	50S1103.17	XYLENE (TOTAL)	3.7 E-3	370. E-6	
10-Dec-03	50S1203.10	1,2,4-TRIMETHYLBENZENE	25. E-3	2.5 E-3	
10-Dec-03	50S1203.10	4-METHYL-2-PENTANONE	23. E-3	2.3 E-3	
10-Dec-03	50S1203.10	ACETONE	400. E-3	40. E-3	
10-Dec-03	50S1203.10	CARBON DISULFIDE	10. E-3	1. E-3	
10-Dec-03	50S1203.10	TOLUENE	6. E-3	600. E-6	

Issued 01/27/2004 13:47:30

**Appendix J**  
**CY 2003 RLWTF Sludge VOC Results by Species**

## RADIOACTIVE LIQUID WASTE TREATMENT FACILITY

VOC results by species for TA50 Plant Sludge

JAN-2003 through DEC-2003

Sample Date	Sample Number	Species	Concentration (mg/L)	Uncertainty (mg/L)
10-Apr-03	50S0403.10	1,1,2-TRICHLORO-1,2,2-TRIFLUORO	1. E-3	140. E-6
23-Jul-03	50S0703.23	1,1,2-TRICHLORO-1,2,2-TRIFLUOROETHANE	4.5 E-3	450. E-6
24-Feb-03	50S0203.24	1,2,4-TRIMETHYLBENZENE	14. E-3	1. E-3
12-Mar-03	50S0303.12	1,2,4-TRIMETHYLBENZENE	8. E-3	850. E-6
10-Apr-03	50S0403.10	1,2,4-TRIMETHYLBENZENE	24. E-3	2. E-3
4-Jun-03	50S0603.04	1,2,4-TRIMETHYLBENZENE	17. E-3	2. E-3
24-Jun-03	50S0603.24	1,2,4-TRIMETHYLBENZENE	8. E-3	800. E-6
23-Jul-03	50S0703.23	1,2,4-TRIMETHYLBENZENE	16. E-3	1.6 E-3
21-Oct-03	50S1003.21	1,2,4-TRIMETHYLBENZENE	48. E-3	4.8 E-3
17-Nov-03	50S1103.17	1,2,4-TRIMETHYLBENZENE	7.9 E-3	790. E-6
10-Dec-03	50S1203.10	1,2,4-TRIMETHYLBENZENE	25. E-3	2.5 E-3
12-Mar-03	50S0303.12	1,2-DICHLOROBENZENE	2. E-3	210. E-6
12-Mar-03	50S0303.12	1,3,5-TRIMETHYLBENZENE	4. E-3	420. E-6
10-Apr-03	50S0403.10	1,3,5-TRIMETHYLBENZENE	4. E-3	360. E-6
12-Mar-03	50S0303.12	1,3-DICHLOROBENZENE	2. E-3	180. E-6
12-Mar-03	50S0303.12	1,4-DICHLOROBENZENE	2. E-3	160. E-6
4-Jun-03	50S0603.04	2-BUTANONE	24. E-3	2. E-3
23-Jul-03	50S0703.23	2-BUTANONE	270. E-3	27. E-3
12-Mar-03	50S0303.12	4-ISOPROPYLTOLUENE	2. E-3	200. E-6
23-Jul-03	50S0703.23	4-METHYL-2-PENTANONE	3.8 E-3	380. E-6
10-Dec-03	50S1203.10	4-METHYL-2-PENTANONE	23. E-3	2.3 E-3
24-Feb-03	50S0203.24	ACETONE	500. E-3	50. E-3
12-Mar-03	50S0303.12	ACETONE	21. E-3	2. E-3
10-Apr-03	50S0403.10	ACETONE	670. E-3	67. E-3
4-Jun-03	50S0603.04	ACETONE	470. E-3	47. E-3
24-Jun-03	50S0603.24	ACETONE	300. E-3	30. E-3
23-Jul-03	50S0703.23	ACETONE	820. E-3	82. E-3
21-Oct-03	50S1003.21	ACETONE	36. E-3	3.6 E-3
10-Dec-03	50S1203.10	ACETONE	400. E-3	40. E-3
24-Jun-03	50S0603.24	CARBON DISULFIDE	4. E-3	430. E-6
23-Jul-03	50S0703.23	CARBON DISULFIDE	18. E-3	1.8 E-3
21-Oct-03	50S1003.21	CARBON DISULFIDE	5.3 E-3	530. E-6
17-Nov-03	50S1103.17	CARBON DISULFIDE	4.4 E-3	440. E-6
10-Dec-03	50S1203.10	CARBON DISULFIDE	10. E-3	1. E-3
12-Mar-03	50S0303.12	DI-N-OCTYL PHTHALATE	1.2 E0	120. E-3
4-Jun-03	50S0603.04	DI-N-OCTYL PHTHALATE	1.7 E0	170. E-3
24-Feb-03	50S0203.24	DICHLORODIFLUOROMETHANE	6. E-3	560. E-6
12-Mar-03	50S0303.12	ETHYLBENZENE	6. E-3	560. E-6
10-Apr-03	50S0403.10	ETHYLBENZENE	3. E-3	300. E-6
23-Jul-03	50S0703.23	ETHYLBENZENE	1.3 E-3	130. E-6
21-Oct-03	50S1003.21	ETHYLBENZENE	1.4 E-3	140. E-6
24-Feb-03	50S0203.24	METHYLENE CHLORIDE	32. E-3	3. E-3
12-Mar-03	50S0303.12	METHYLENE CHLORIDE	25. E-3	2. E-3



VOC results by species for TA50 Plant Sludge				Page 2 of 2	
Sample Date	Sample Number	Species	Concentration (mg/L)	Uncertainty (mg/L)	
10-Apr-03	50S0403.10	METHYLENE CHLORIDE	19. E-3	2. E-3	
4-Jun-03	50S0603.04	METHYLENE CHLORIDE	14. E-3	1. E-3	
24-Jun-03	50S0603.24	METHYLENE CHLORIDE	69. E-3	7. E-3	
23-Jul-03	50S0703.23	METHYLENE CHLORIDE	8.6 E-3	860. E-6	
12-Mar-03	50S0303.12	SEC-BUTYLBENZENE	2. E-3	160. E-6	
23-Jul-03	50S0703.23	STYRENE	630. E-6	63. E-6	
12-Mar-03	50S0303.12	TETRACHLOROETHENE	6. E-3	590. E-6	
10-Apr-03	50S0403.10	TETRACHLOROETHENE	17. E-3	2. E-3	
21-Oct-03	50S1003.21	TETRACHLOROETHENE	15. E-3	1.5 E-3	
17-Nov-03	50S1103.17	TETRACHLOROETHENE	1.3 E-3	130. E-6	
24-Feb-03	50S0203.24	TOLUENE	5. E-3	450. E-6	
12-Mar-03	50S0303.12	TOLUENE	6. E-3	610. E-6	
10-Apr-03	50S0403.10	TOLUENE	7. E-3	650. E-6	
4-Jun-03	50S0603.04	TOLUENE	7. E-3	720. E-6	
24-Jun-03	50S0603.24	TOLUENE	2. E-3	190. E-6	
23-Jul-03	50S0703.23	TOLUENE	4.4 E-3	440. E-6	
21-Oct-03	50S1003.21	TOLUENE	3.3 E-3	330. E-6	
17-Nov-03	50S1103.17	TOLUENE	3. E-3	300. E-6	
10-Dec-03	50S1203.10	TOLUENE	6. E-3	600. E-6	
12-Mar-03	50S0303.12	XYLENE (TOTAL)	25. E-3	2. E-3	
10-Apr-03	50S0403.10	XYLENE (TOTAL)	14. E-3	1. E-3	
4-Jun-03	50S0603.04	XYLENE (TOTAL)	6. E-3	570. E-6	
23-Jul-03	50S0703.23	XYLENE (TOTAL)	6.5 E-3	650. E-6	
21-Oct-03	50S1003.21	XYLENE (TOTAL)	4.3 E-3	430. E-6	
17-Nov-03	50S1103.17	XYLENE (TOTAL)	3.7 E-3	370. E-6	

Issued 01/27/2004 13:47:40

**Appendix K**  
**CY 2003 RLWTF Sludge SVOC Results by Sample**

### RADIOACTIVE LIQUID WASTE TREATMENT FACILITY

SVOC results by sample for TA50 Plant Sludge  
JAN-2003 through DEC-2003

Sample Date	Sample Number	Species	Concentration (mg/L)	Uncertainty (mg/L)
24-Feb-03	50S0203.24	BIS(2-ETHYLHEXYL)PHTHALATE	14. E0	1.4 E0
12-Mar-03	50S0303.12	BIS(2-ETHYLHEXYL)PHTHALATE	24. E0	2.4 E0
10-Apr-03	50S0403.10	BIS(2-ETHYLHEXYL)PHTHALATE	24. E0	2.4 E0
4-Jun-03	50S0603.04	BIS(2-ETHYLHEXYL)PHTHALATE	21. E0	2.1 E0
24-Jun-03	50S0603.24	BIS(2-ETHYLHEXYL)PHTHALATE	14. E0	1.4 E0
23-Jul-03	50S0703.23	BIS(2-ETHYLHEXYL)PHTHALATE	8.5 E0	850. E-3
21-Oct-03	50S1003.21	BIS(2-ETHYLHEXYL)PHTHALATE	21. E0	2.1 E0
17-Nov-03	50S1103.17	BIS(2-ETHYLHEXYL)PHTHALATE	8.8 E0	880. E-3
10-Dec-03	50S1203.10	BIS(2-ETHYLHEXYL)PHTHALATE	9.9 E0	990. E-3

Issued 01/27/2004 13:47:50

**Appendix L**  
**CY 2003 RLWTF Sludge SVOC Results by Species**

## RADIOACTIVE LIQUID WASTE TREATMENT FACILITY

SVOC results by species for TA50 Plant Sludge  
JAN-2003 through DEC-2003

Sample Date	Sample Number	Species	Concentration (mg/L)	Uncertainty (mg/L)
24-Feb-03	50S0203.24	BIS(2-ETHYLHEXYL)PHTHALATE	14. E0	1.4 E0
12-Mar-03	50S0303.12	BIS(2-ETHYLHEXYL)PHTHALATE	24. E0	2.4 E0
10-Apr-03	50S0403.10	BIS(2-ETHYLHEXYL)PHTHALATE	24. E0	2.4 E0
4-Jun-03	50S0603.04	BIS(2-ETHYLHEXYL)PHTHALATE	21. E0	2.1 E0
24-Jun-03	50S0603.24	BIS(2-ETHYLHEXYL)PHTHALATE	14. E0	1.4 E0
23-Jul-03	50S0703.23	BIS(2-ETHYLHEXYL)PHTHALATE	8.5 E0	850. E-3
21-Oct-03	50S1003.21	BIS(2-ETHYLHEXYL)PHTHALATE	21. E0	2.1 E0
17-Nov-03	50S1103.17	BIS(2-ETHYLHEXYL)PHTHALATE	8.8 E0	880. E-3
10-Dec-03	50S1203.10	BIS(2-ETHYLHEXYL)PHTHALATE	9.9 E0	990. E-3

Issued 01/27/2004 13:47:53



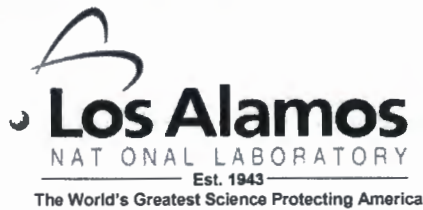

*Risk Reduction & Environmental Stewardship Division  
Water Quality & Hydrology Group (RRES-WQH)*

P.O. Box 1663, Mail Stop K497  
Los Alamos, New Mexico 87545  
(505) 667-7969/FAX: (505) 665-9344

Date: April 28, 2004  
Refer to: RRES-WQH: 04-073

Mr. Curt Frischkorn  
Ground Water Pollution Prevention Section  
Ground Water Quality Bureau  
New Mexico Environment Department  
P.O. Box 26110  
Santa Fe, New Mexico 87502

**SUBJECT: TA-50 RADIOACTIVE LIQUID WASTE TREATMENT FACILITY, GROUND WATER DISCHARGE PLAN (DP-1132) QUARTERLY REPORT, FIRST QUARTER 2004**

Dear Mr. Frischkorn:

This letter is intended to serve as Los Alamos National Laboratory's quarterly Ground Water Discharge Plan (DP-1132) report for the TA-50 Radioactive Liquid Waste Treatment Facility (RLWTF) for the first quarter of 2004. Since the first quarter of 1999, Los Alamos National Laboratory has provided your agency with voluntary quarterly reports containing analytical results from effluent and ground water monitoring.

Mortandad Canyon Alluvial Ground Water Monitoring Results

Table 1.0 presents the analytical results from sampling conducted at four Mortandad Canyon alluvial monitoring wells during the first quarter of 2004. All of the analytical results from MCO-3, MCO-4B, and MCO-7 were below New Mexico Water Quality Control Commission (NM WQCC) Regulation 3103 standards for nitrate-nitrogen (NO<sub>3</sub>-N), fluoride (F), and total dissolved solids (TDS). There was not sufficient water available in MCO-6 for sampling.

RLWTF Effluent Monitoring Results

Table 2.0 presents the analytical results from weekly composite sampling of the RLWTF's effluent. The final weekly composite (FWC) samples are flow-proportioned composite samples prepared from each tank of effluent generated by the RLWTF during a 7-day period. Samples are submitted to General Engineering Laboratories (GEL), Charleston, SC, for analysis. None of the sample results from the first quarter exceeded the NM WQCC Regulation 3103 standards for NO<sub>3</sub>-N, F, and TDS with the exception of a nitrate+nitrite-N result of 54.8 mg/L on March 7, 2004. This result, however, was not consistent with a nitrate+nitrite-N result of 9.10 mg/L obtained by the TA-50 RLWTF analytical laboratory from a duplicate sample. The original sample was re-analyzed by GEL (GEL had sufficient sample volume in storage for re-analysis); on April 26, 2004, GEL reported a

re-analysis result of 9.50H mg/L. A data qualifier of ("H" flag) was assigned to the sample result because the analytical holding time was exceeded. In addition to the FWC sampling, each of the two effluent tanks discharged during the week of March 1-7, 2004, were screened for nitrates (NO<sub>3</sub>-N) using a HACH DR/2000 direct reading spectrophotometer. Nitrate (NO<sub>3</sub>-N) results for effluent tanks discharged on March 3<sup>rd</sup> and March 5<sup>th</sup> were 8.65 mg/L and 9.7 mg/L, respectively.

To recap, GEL reported an elevated nitrate+nitrite-N result of 54.8 mg/L in a FWC sample prepared on March 7, 2004. However, this value conflicted with the nitrate+nitrite-N result of 9.10 mg/L obtained by the RLWTF's analytical laboratory that analyzed a duplicate sample. Re-analysis of the original sample by GEL yielded a result of 9.50H mg/L. Nitrate (NO<sub>3</sub>-N) screening results for effluent discharged during the week were 8.65 mg/L and 9.7 mg/L. These data suggest that GEL's initial result of 54.8 mg/L was an anomaly and not representative of the effluent discharged during the week of March 1-7, 2004.

Table 3.0 presents the final monthly composite (FMC) sample results for nitrates (NO<sub>3</sub>-N) and perchlorate for the 1<sup>st</sup> quarter of 2004. The FMC samples are flow-proportioned composite samples prepared from each tank of effluent generated by the RLWTF during the month. An internal analytical laboratory located at the TA-50 RLWTF analyzes the samples.

Please contact me at (505) 667-7969 if you would like additional information regarding this quarterly report.

Sincerely,



Bob Beers  
Water Quality & Hydrology Group

BB/lm

Cy: M. Leavitt, NMED/SWQB, Santa Fe, NM  
C. Voorhees, NMED/DOE/OB, Santa Fe, NM  
R. Ford-Schmid, NMED/DOE/OB, Santa Fe, NM  
J. Vozella, NNSA/LASO, MS A316  
G. Turner, NNSA/LASO, MS A316  
J. Holt, ADO, MS A104  
T. Stanford, FWO-DO, MS K492  
D. Mclain, FWO-WFM, MS J593  
R. Alexander, FWO-WFM, MS E518  
D. Moss, FWO-WFM, MS E518  
P. Worland, FWO-WFM, MS E518  
B. Ramsey, RRES-DO, MS J591  
T. George, RRES-DO, MS J591



Mr. Curt Frischkorn  
RRES-WQH: 04-073

-3-

April 28, 2004

CY (continued):

K. Hargis, RRES-DO, MS J591  
D. Stavert, RRES-EP, MS J591  
C. Nylander, RRES-GP, MS M992  
S. Rae, RRES-WQH, MS K497  
D. Rogers, RRES-WQH, MS K497  
M. Saladen, RRES-WQH, MS K497  
RRES-WQH File, MS K497  
IM-5, MS A150

*Radioactive Liquid Waste Treatment Facility  
Ground Water Discharge Plan (DP-1132) Quarterly Report  
1st Quarter, 2004*

**Table 1.0. Mortandad Canyon Alluvial Monitoring Wells Analytical Results.**

Sampling Location	Sample Date	Perchlorate by LC/MS/MS <sup>3</sup> (ug/L)	Perchlorate by IC <sup>4</sup> (ug/L)	NO <sub>3</sub> +NO <sub>2</sub> -N (mg/L)	TKN (mg/L)	NH <sub>3</sub> -N (mg/L)	TDS (mg/L)	F (mg/L)
MCO-3	3/25/2004	5.07	4.43J	1.32	0.67	<0.050	320	0.35
MCO-4B	3/22/2004	8.73	8.13J	1.46	0.54	<0.050	371	0.71
MCO-6	3/22/2004	NS <sup>1</sup>	NS	NS	NS	NS	NS	NS
MCO-7	3/22/2004	65.8	62.9	2.62	0.53	<0.050	366	1.20
<i>NM WQCC 3103 Ground Water Standards (mg/L)</i>				<i>10<sup>2</sup></i>			<i>1000</i>	<i>1.6</i>

**Notes:**

<sup>1</sup>NS means that there was not sufficient water available for sampling.

<sup>2</sup>The NMWQCC Regulation 3103 Ground Water Standard is for NO<sub>3</sub>-N.

<sup>3</sup>LC/MS/MS means perchlorate analysis by Liquid Chromatography/Mass Spectrometry/Mass Spectrometry.

<sup>4</sup>IC means the EPA Method 314, perchlorate analysis by Ion Chromatography.

J indicates an estimated value. The result was less than the reporting limit, but greater than the detection limit.

All analyses by General Engineering Laboratories, Charleston, SC.

All samples filtered with the exception of perchlorate.

: 02472

Radioactive Liquid Waste Treatment Facility  
 Ground Water Discharge Plan (DP-1132) Quarterly Report  
 1st Quarter, 2004

Table 2.0. RLWTF Final Weekly Composite (FWC) Effluent Monitoring Results, 1st Quarter, 2004.

Monitoring Period	Sample Composite Date	RLWTF FWC Results (mg/L)			
		GEL <sup>1</sup> Result NO3+NO2-N	LANL <sup>2</sup> Result NO3+NO2-N	Fluoride <sup>1</sup>	TDS <sup>1</sup>
<b>January, 2004</b>	1/7/2004 <sup>3</sup>	NA	NA	NA	NA
	1/11/2004	1.58	1.91	0.11	122
	1/18/2004	0.92	1.44	0.07	88
	1/25/2004	0.27	0.63	0.10	180
<b>February, 2004</b>	2/1/2004	0.32	0.54	0.10	83
	2/8/2004	0.45	0.76	0.12	81
	2/15/2004	0.20	0.58	0.12	73
	2/22/2004	0.29	0.72	0.14	110
	2/29/2004	1.32	1.46	0.07	141
<b>March, 2004</b>	3/7/2004	54.8 <sup>4</sup>	9.10	<0.05	124
	3/7/2004 re-analysis	9.50H <sup>5</sup>			
	3/14/2004	3.07	7.18	<0.05	153
	3/21/2004	4.90	4.79	<0.05	127
	3/28/2004	results pending	results pending	results pending	results pending
<b>1st Quarter 2004 Averages (mg/L)</b>		<b>6.19<sup>6</sup></b>	<b>2.65</b>	<b>0.10</b>	<b>117</b>
<i>NM WQCC 3103. Ground Water Standards (mg/L)</i>		<i>10.0<sup>7</sup></i>		<i>1.6</i>	<i>1000</i>

Notes:

<sup>1</sup>General Engineering Laboratories, Inc., Charleston, SC

<sup>2</sup>Los Alamos National Laboratory's TA-50 RLWTF analytical laboratory.

<sup>3</sup>No effluent was discharged during the week prior to this date.

<sup>4</sup>Re-analysis of this sample by GEL 17 days later produced a result of 9.05 mg/L.

<sup>5</sup>Re-analysis of the 3/7/04 FWC sample (ID#04.71310) by GEL on 4/22/0 produced a result of 9.50 mg/L. This value was qualified with an "H" flag to indicate that the analytical holding time was exceeded.

<sup>6</sup>The quarterly average was calculated using the 3/7/04 initial NO3+NO2-N result of 54.8 mg/L. If calculated using the re-analysis result (9.50 mg/L) then the average decreases to 2.07 mg/L.

<sup>7</sup>The NM WQCC Regulation 3103 Ground Water Standard is for nitrate (NO3-N).

02473

*Radioactive Liquid Waste Treatment Facility  
Ground Water Discharge Plan (DP-1132) Quarterly Report  
1st Quarter, 2004*

**Table 3.0. RLWTF Final Monthly Composite (FMC) Effluent Monitoring Analytical Results**

Monitoring Period	Final Monthly Composite (FMC) Analytical Results	
	NO3-N (mg/L)	Perchlorate by IC (ug/L)
<u>January, 2004</u>	0.41	0.0 +/-1
<u>February, 2004</u>	0.05	0.0 +/-1
<u>March, 2004</u>	5.0	0.0 +/-1
<i>NM WQCC 3103. Ground Water Standards</i>	<i>10.0</i>	<i>NA</i>

**Notes:**

All analyses by the Laboratory's TA-50 RLWTF analytical laboratory.

02474



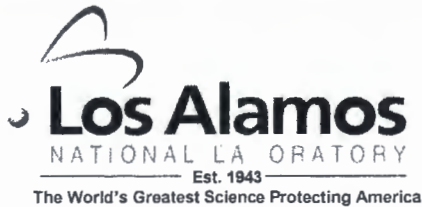

Risk Reduction & Environmental Stewardship Division  
Water Quality & Hydrology Group (RRES-WQH)  
P.O. Box 1663, Mail Stop K497  
Los Alamos, New Mexico 87545  
(505) 665-1859/FAX: (505) 665-9344

Date: May 13, 2004  
Refer to: RRES-WQH: 04-083

Mr. Ed Wilmot  
Manager  
Los Alamos Site Office, MS A316  
National Nuclear Security Administration  
528 35<sup>th</sup> Street  
Los Alamos, NM 87544

Mr. Joseph Vozella  
Assistant Manager for Facility Operations  
Los Alamos Site Office, MS A316  
National Nuclear Security Administration  
528 35<sup>th</sup> Street  
Los Alamos, NM 87544

**SUBJECT: RADIOACTIVE EFFLUENT QUALITY AT NPDES OUTFALL 051, TA-50,  
FEBRUARY 2004 AND MARCH 2004**

Dear Mr. Wilmot and Mr. Vozella:

Enclosed are the monthly monitoring reports for NPDES Outfall 051 for radioactive effluent quality data for February, 2004 and March, 2004. These reports include the monthly value (monthly average) compared with the DOE Derived Concentration Guideline (DCG) value for each parameter analyzed. The monthly values are equal composites of all discharges that occurred during the monitoring period.

There were 7 releases (504,200 liters) in February, 2004 and 11 releases (800,200 liters) in March, 2004 to Mortandad Canyon from the TA-50 Treatment Facility. There were no exceedances of DCGs for individual radionuclides during the monitoring periods. Additionally, the sum of the fractions for the radionuclides did not exceed the DCG value of 1.

Please note, the monthly composite results for perchlorate and nitrate are now being provided in the quarterly Ground Water Discharge Plan report submitted to NMED.

Please contact me at 665-1859 or Mike Saladen at (505) 665-6085 if additional information would be helpful.

Sincerely,

  
Steven Rae  
Group Leader  
Water Quality & Hydrology Group

SR:MS/tml

Enclosure: a/s

Cy: C. Voorhees, NMED/DOE/OB, Santa Fe, NM, w/enc.  
M. Leavitt, NMED/SWQB, Santa Fe, NM, w/enc.  
K. Frischkorn, NMED/GWB, Santa Fe, NM, w/enc.  
M. Johansen, NNSA/LASO, w/enc., MS A316  
G. Turner, NNSA/LASO, w/enc., MS A316  
B. Enz, NNSA/LASO, w/enc., MS A316  
A. Stanford, FWO-DO, w/enc., MS K492  
D. McLain, FWO-RLW, w/enc., MS J595  
D. Moss, FWO-RLW, w/enc., MS E518  
B. Ramsey, RRES-DO, w/enc., MS J591  
K. Hargis, RRES-DO, w/enc., MS J591  
T. George, RRES-DO, w/enc. MS J591  
D. Stavert, RRES-EP, w/enc., MS J591  
M. Saladen, RRES-WQH, w/enc., MS K497  
RRES-WQH File, w/enc., MS K497  
IM-5, w/enc., MS A150

# TA50-1 Effluent Discharge and Removal

## FEBRUARY, 2004

Species	Guideline as (uCi/ml)	Guideline as (Ci/L)	Effluent (Ci/L)	Monthly Eff/Guide Ratio	Twelve Month Ratio
Am-241	.00000003	30e-12	.64e-12	.021	.152
As-74	.00004	40e-9	< 1.0e-15	0	.002
Be-7	.001	1e-6	< 1.0e-15	0	.0000377
Ce-141	.00005	50e-9	< 1.0e-15	0	.0003126
Cs-137	.000003	3e-9	8.7e-12	.003	.011
Na-22	.00001	10e-9	< 1.0e-15	0	.0001297
Pu-238	.00000004	40e-12	4.5e-12	.113	.242
Pu-239	.00000003	30e-12	2e-12	.067	.118
Ra-228	.0000001	100e-12	< 1.0e-15	0	.009
Sr-85	.00007	70e-9	< 1.0e-15	0	.0000525
TRITIUM	.002	2e-6	6.2e-9	.003	.005
Th-232	.00000005	50e-12	.06e-12	.001	.0002353
U-238	.0000006	600e-12	< 1.0e-15	0	.000017
Sum				.208	.54

( A concentration value less than detection limit is presented as zero. )

7 discharges 504,200 liters (volume) discharged

Reviewed by: 113354 on 04-MAY-04



# TA50-1 Effluent Discharge and Removal

## MARCH, 2004

Species	Guideline as (uCi/ml)	Guideline as (Ci/L)	Effluent (Ci/L)	Monthly Eff/Guide Ratio	Twelve Month Ratio
Am-241	.00000003	30e-12	< 1.0e-15	0	.129
As-74	.00004	40e-9	< 1.0e-15	0	.002
Be-7	.001	1e-6	< 1.0e-15	0	.0000383
Ce-141	.00005	50e-9	< 1.0e-15	0	.0003176
Cs-137	.000003	3e-9	6.4e-12	.002	.002
Pu-238	.00000004	40e-12	2.2e-12	.055	.237
Pu-239	.00000003	30e-12	1.9e-12	.063	.116
Ra-228	.0000001	100e-12	< 1.0e-15	0	.009
Sr-85	.00007	70e-9	< 1.0e-15	0	.0000534
TRITIUM	.002	2e-6	9.1e-9	.005	.005
Th-232	.00000005	50e-12	.08e-12	.002	.0003639
Sum				.127	.501

( A concentration value less than detection limit is presented as zero. )

11 discharges 800,200 liters (volume) discharged

Reviewed by: 113354 on 04-MAY-04

# **Assessment of potential contaminant pathways through saturated zone in the vicinity of Mortandad canyon**

**Velimir V Vesselinov**

**Los Alamos National Laboratory  
Groundwater Protection Program  
Quarterly Meeting  
July 13, 2004**

# Groundwater Pathway Assessment (GWPA)

- **GOAL:** estimate the probability of key contaminants to be captured by existing water supply wells within a specified time frame
- **Based on existing numerical/conceptual models (saturated/unsaturated)**
- **Probabilistic analysis of the possible contaminant pathways**
- **Selected set of important model parameters are treated as random variables with specified uncertainty (based on expert knowledge/data)**
- **Parameter uncertainty is propagated to model prediction uncertainty using Monte Carlo analysis**
- **Managed by ER program; funded by ER and HWP (partially)**

# 3D Groundwater Numerical Model of the regional aquifer beneath LANL

- **Model is based on multi-disciplinary dataset (geologic, geophysical, hydrologic, and geochemical)**
  
- **Model allows:**
  - assessment of aquifer properties**
  - assessment of groundwater resources**
  - assessment of groundwater transport of contaminants**
  - evaluation of drought conditions (reduced recharge/increased pumping)**
  - capture-zone delineation for groundwater-supply systems**
  - coupling with smaller local-scale models**
  
- **Model is developed using**
  - simulating code FEHM (Zyvoloski et al., 2001)**
  - grid-generating code LaGriT (Trease et al., 1996)**
  - parameter-estimation code PEST (Doherty, 2001)**

02483

## **Important aspects of the modeling approach used in GWPA**

- **Variability in the pumping rates of water-supply wells has dominant impact on the flow structure**
- **Uncertainty in medium heterogeneity and spatial/temporal variability of recharge are ignored (for the moment)**
- **Permeabilities of various hydrostratigraphic units are assumed to be perfectly known**
- **Dispersivity and porosities of various hydrostratigraphic and pumping rates are assumed to be random variables**
- **Flow is at steady-state**
- **Flow is confined**
- **Impact of water-table movement is ignored**
- **Impact of perched/phreatic zones is ignored**
- **Impact of transients in the recharge along the canyon is ignored**
- **Flow through unsaturated zone assumed 1D/vertical**
- **Simplified coupling with unsaturated zone model (perfect transfer of transient contaminant fluxes through the interface)**

02484

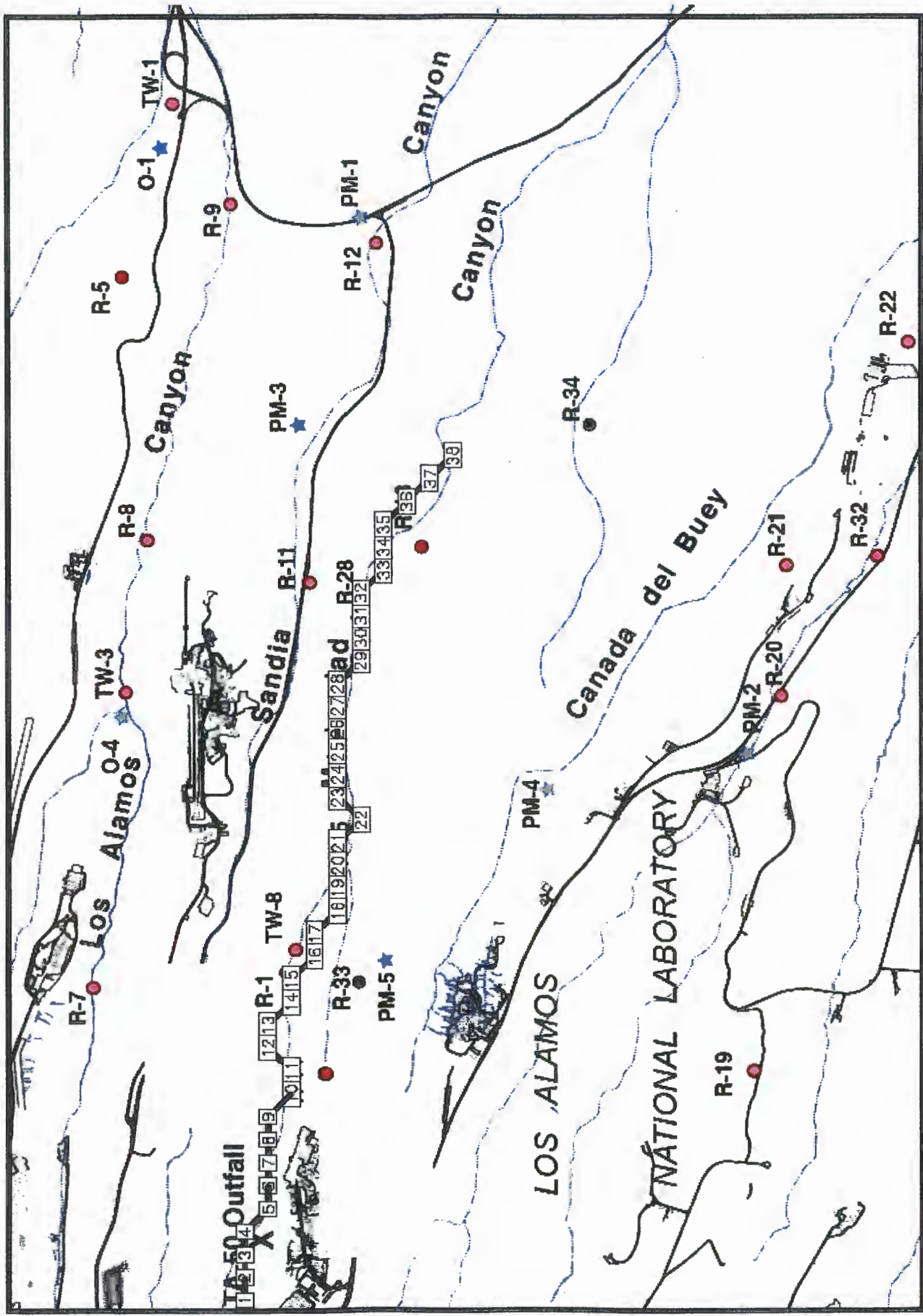

# Computational Grid

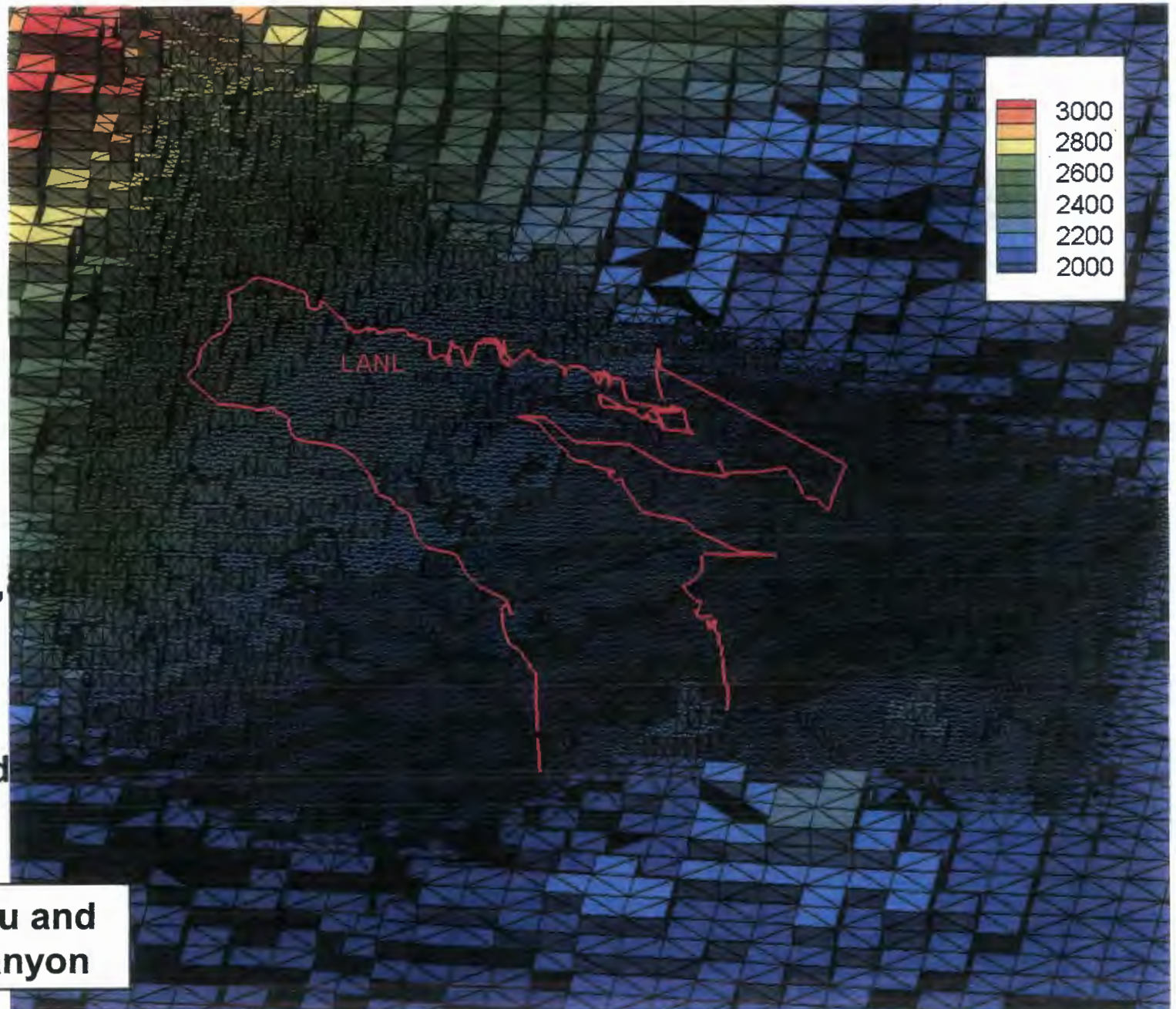

**Nodes: 435,937**  
**Elements: 2,420,**

**3D grid extends  
up to the ground  
surface**

**Pajarito Plateau and  
White Rock Canyon**

# Variation of annually-averaged pumping rates

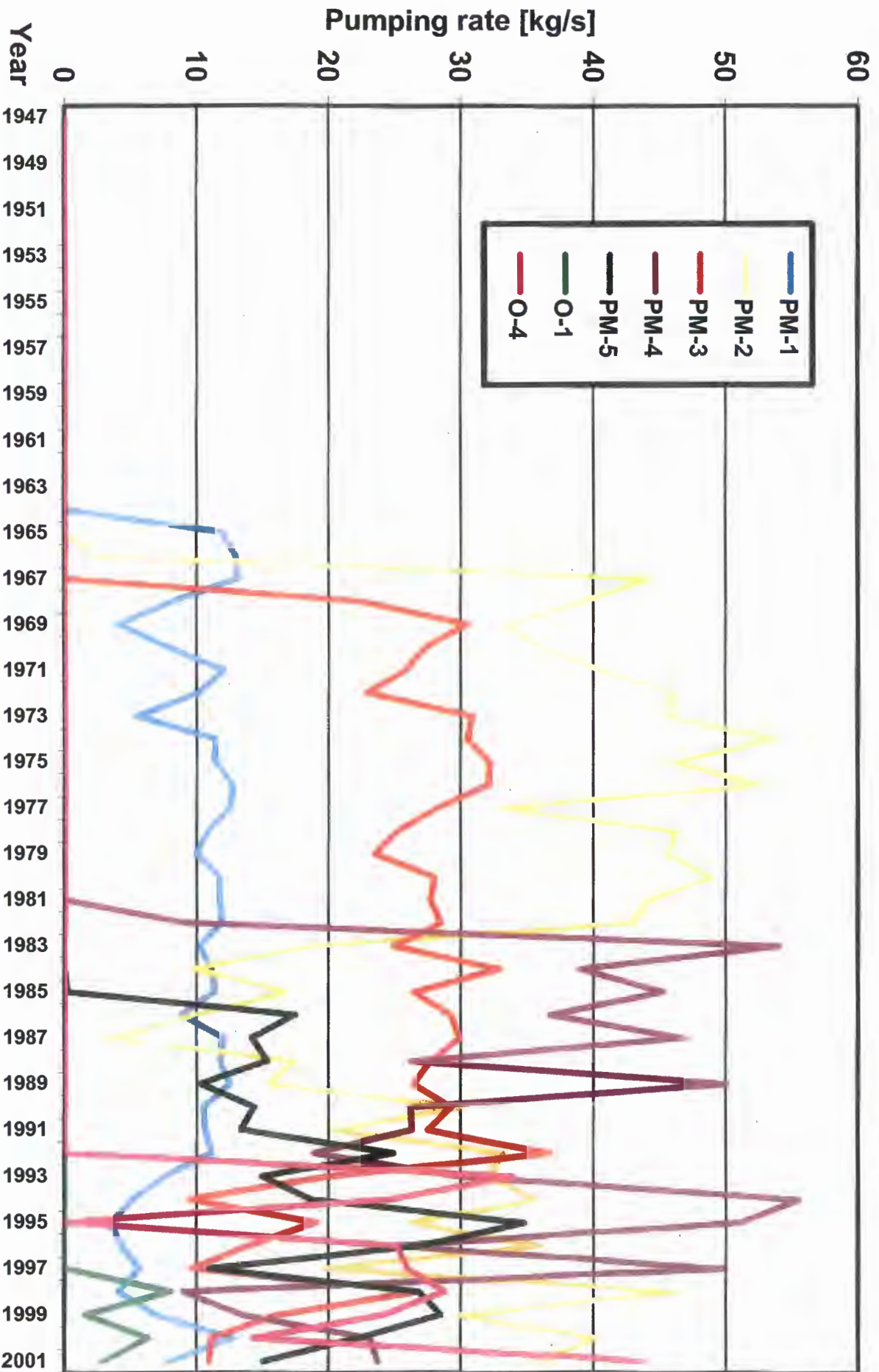



# Pumping time per year

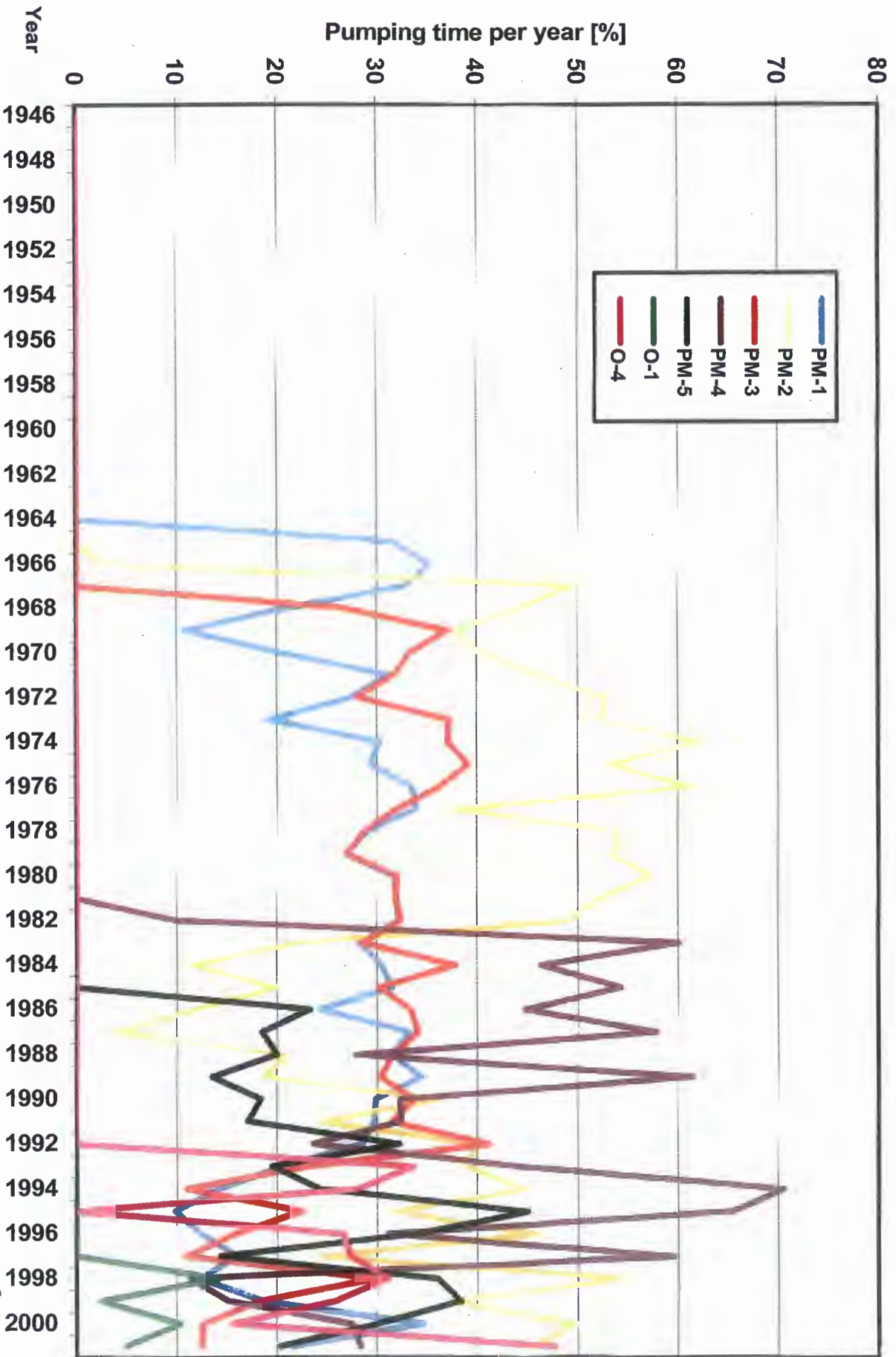

02489 : 68h20

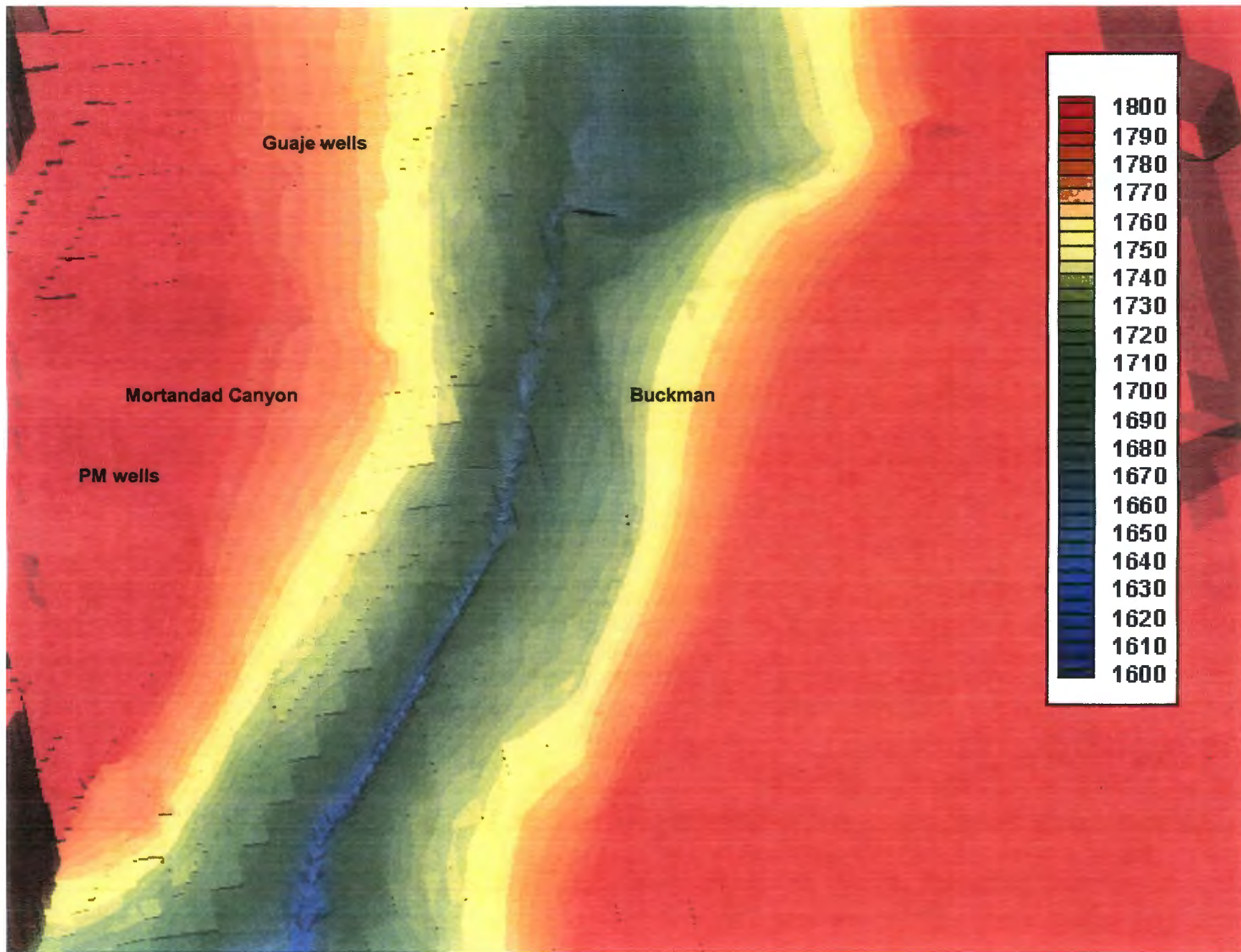

# Capture zones at the water-table

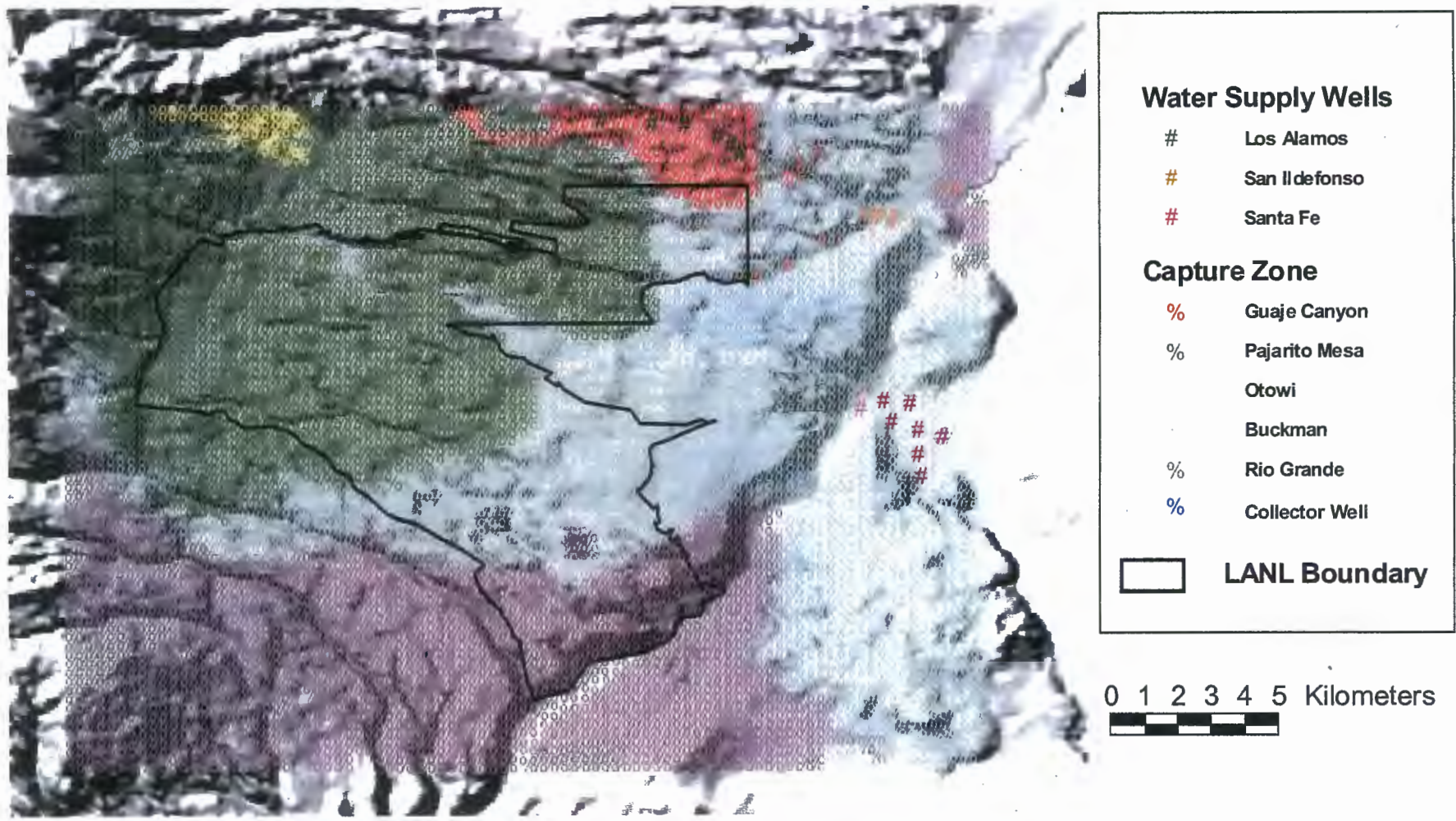

02490

# Capture zones at the water-table

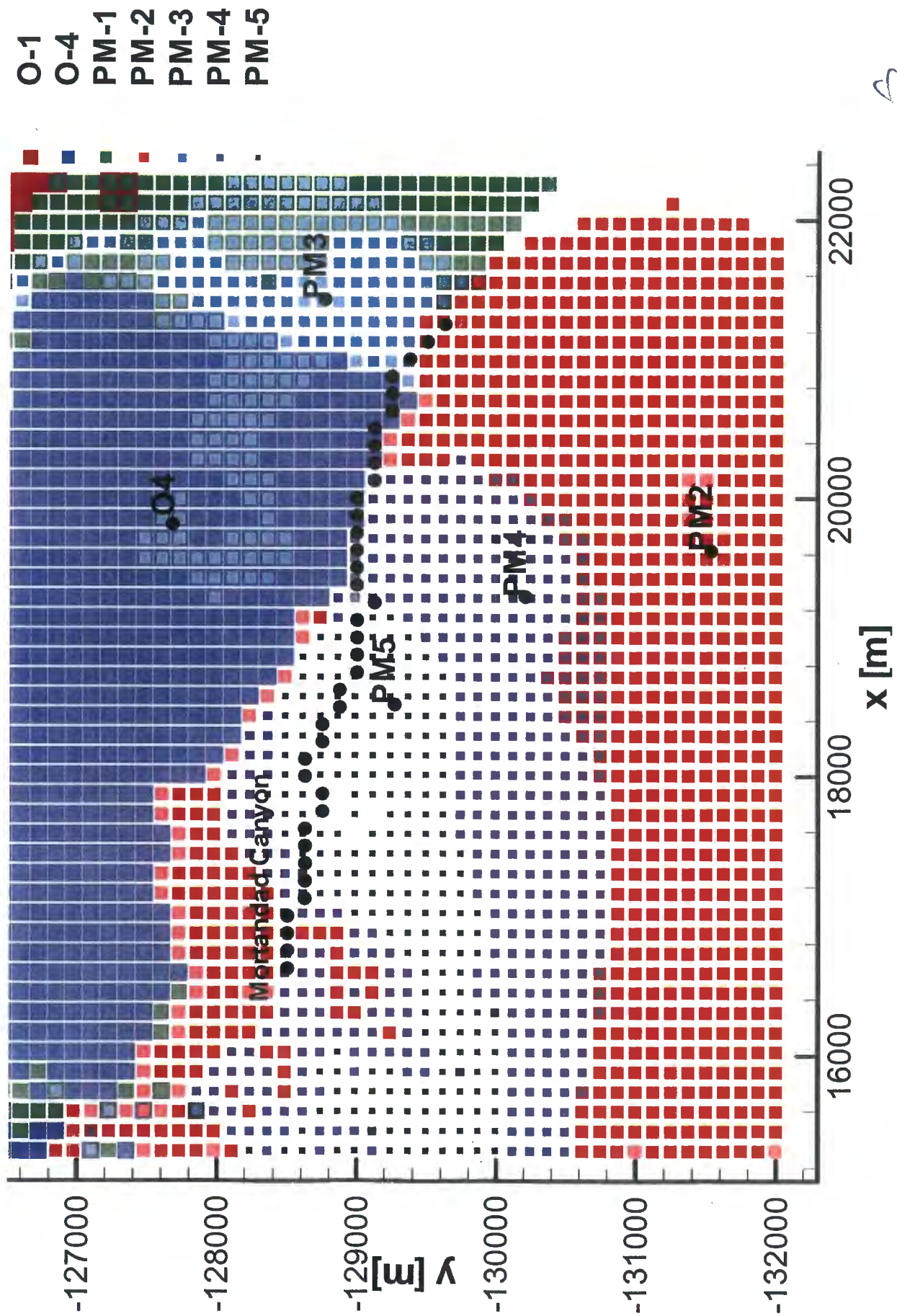

# Breakthrough curve at PM-3 1 realization

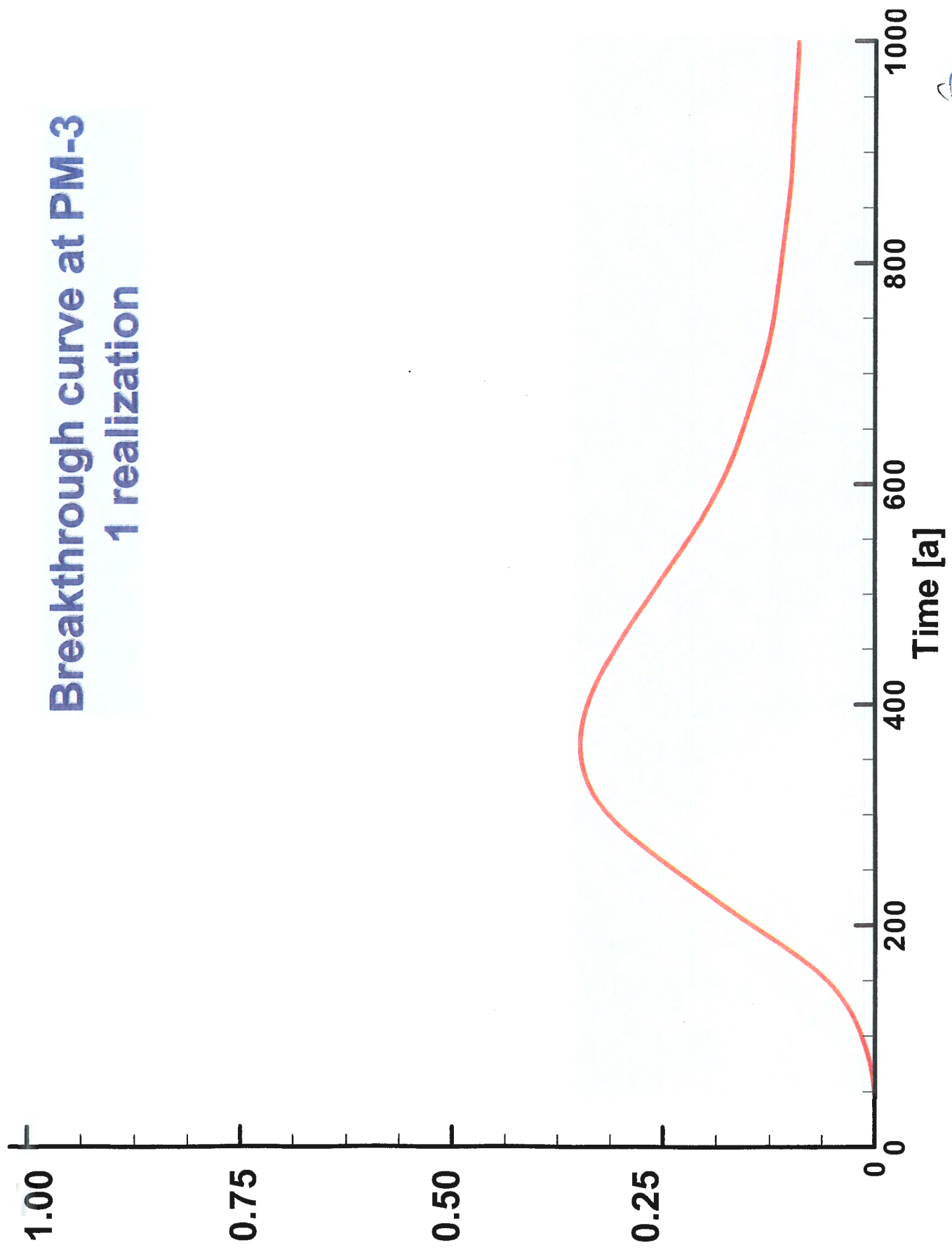

# Breakthrough curves at PM-3 1000 realizations

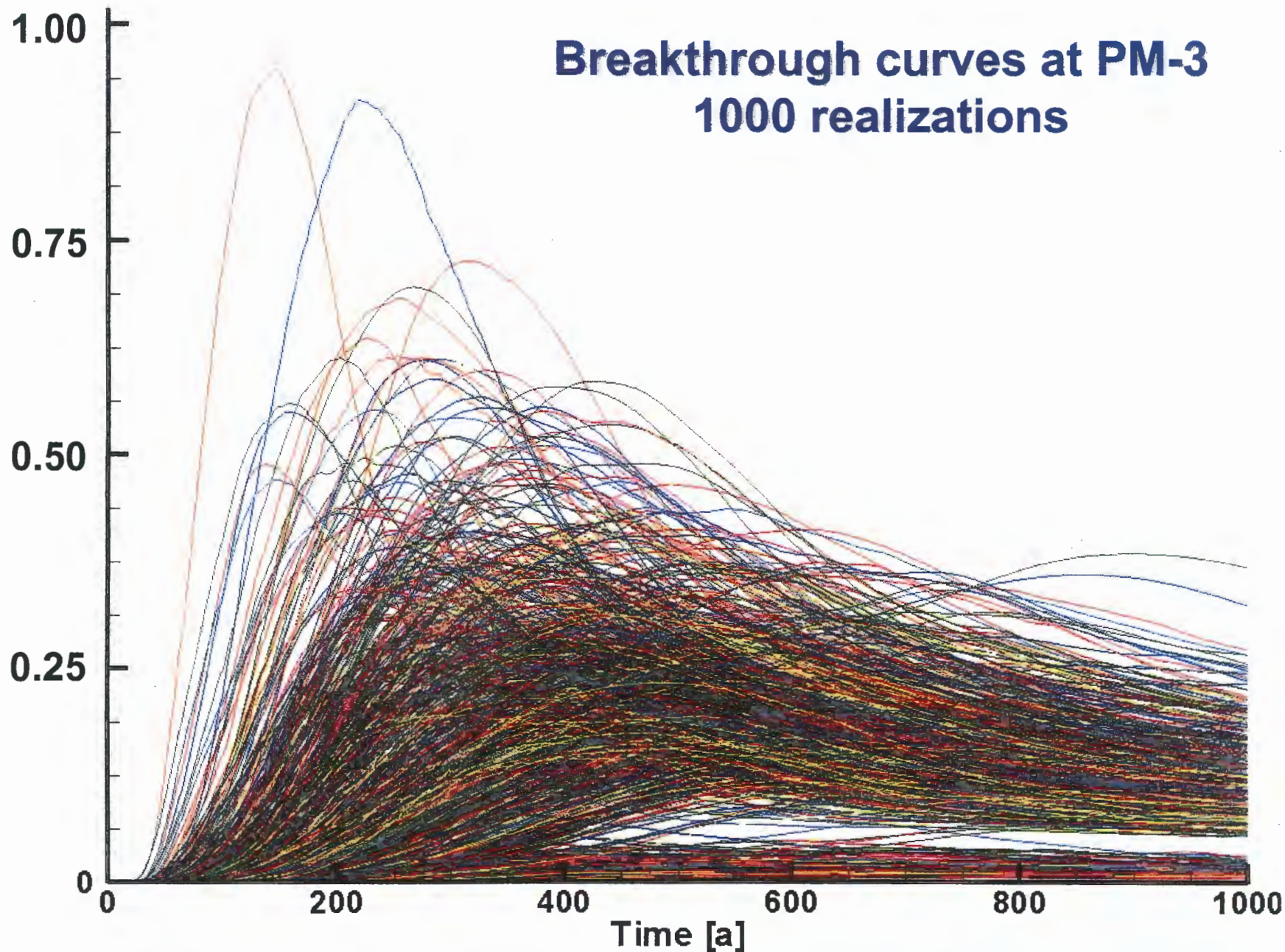

02493

Model animation of contaminant transport from the water table beneath Mortandad canyon to water-supply wells

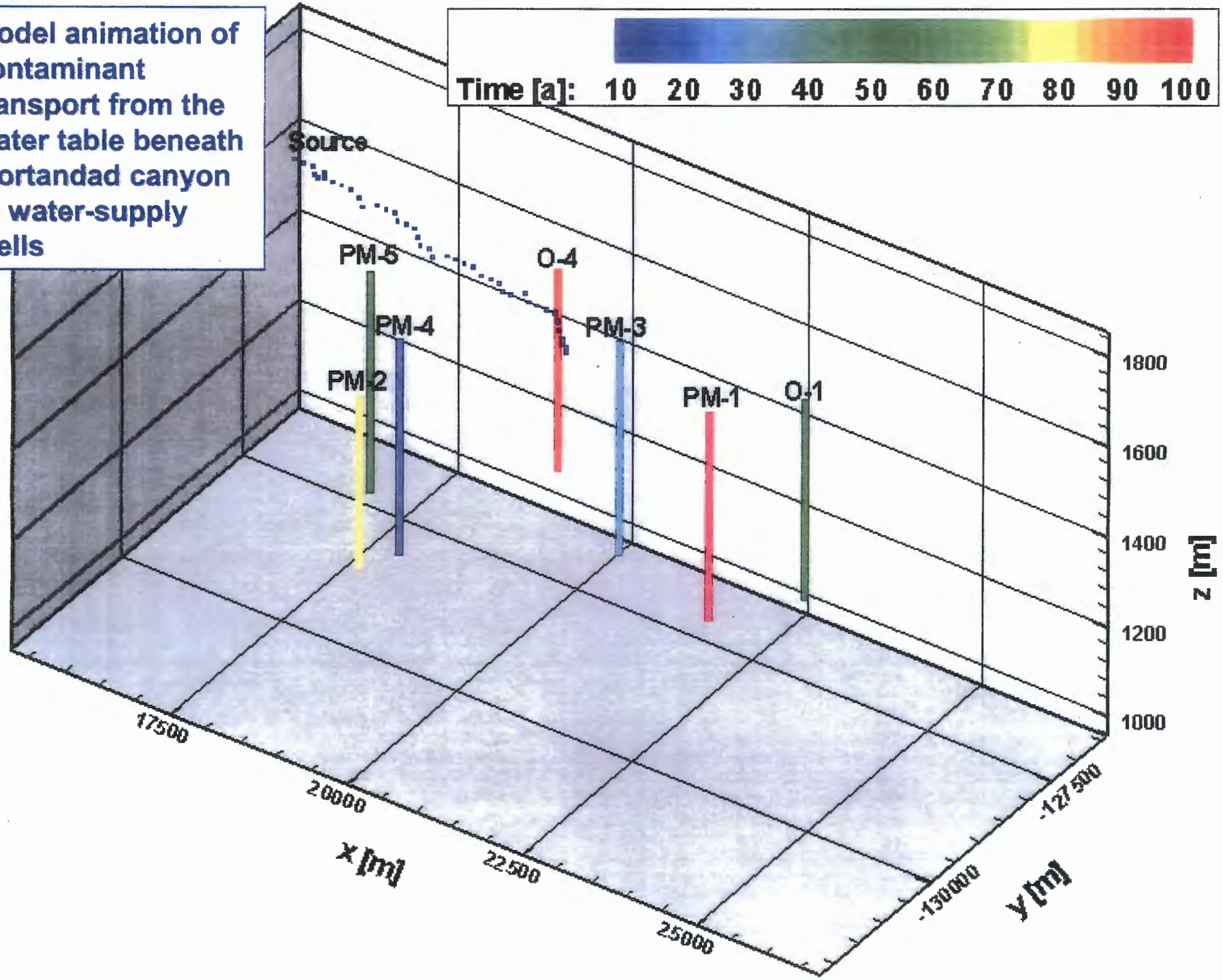

02494 : 6h20

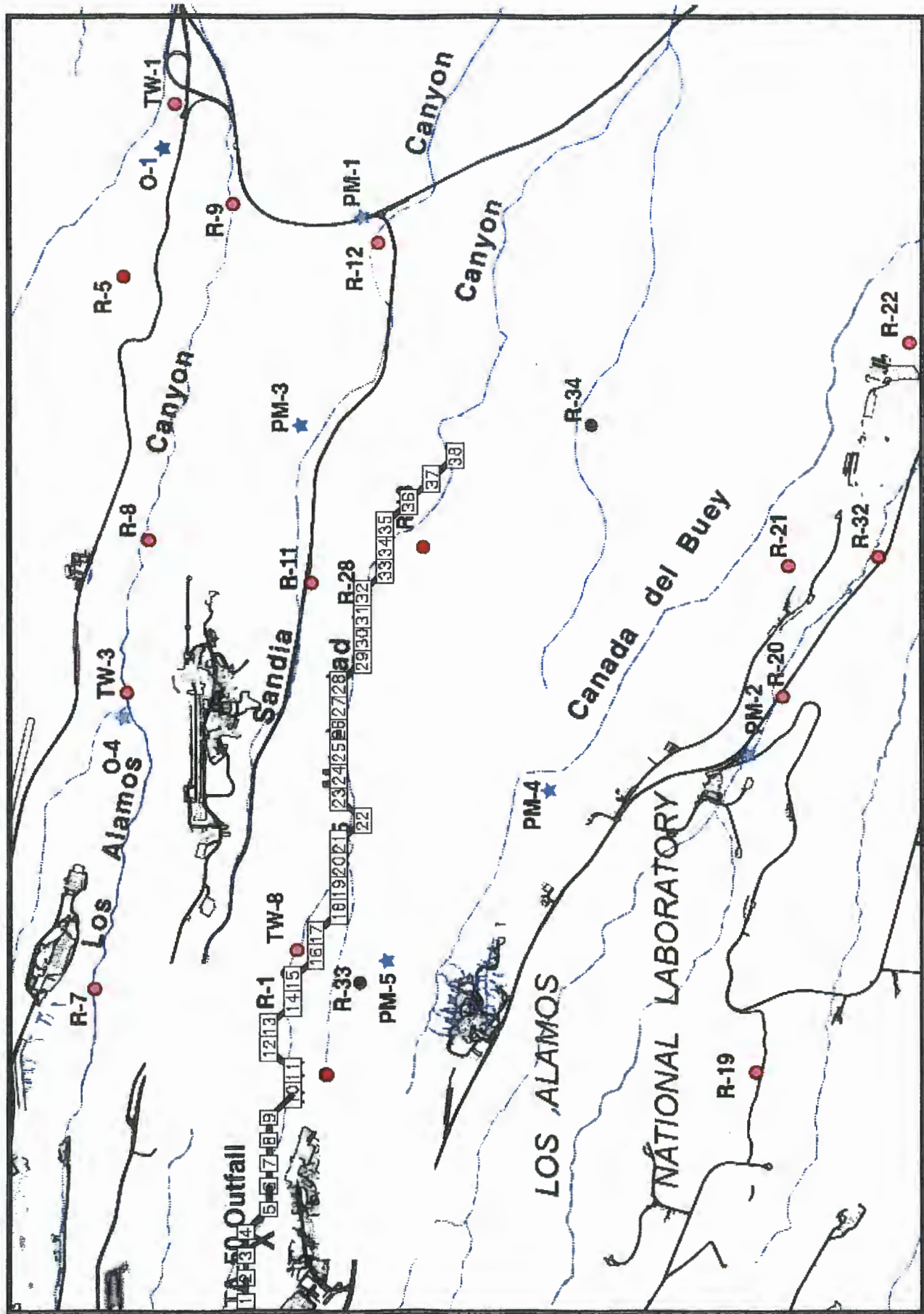



# Portion of contaminant releases captured by the water-supply wells

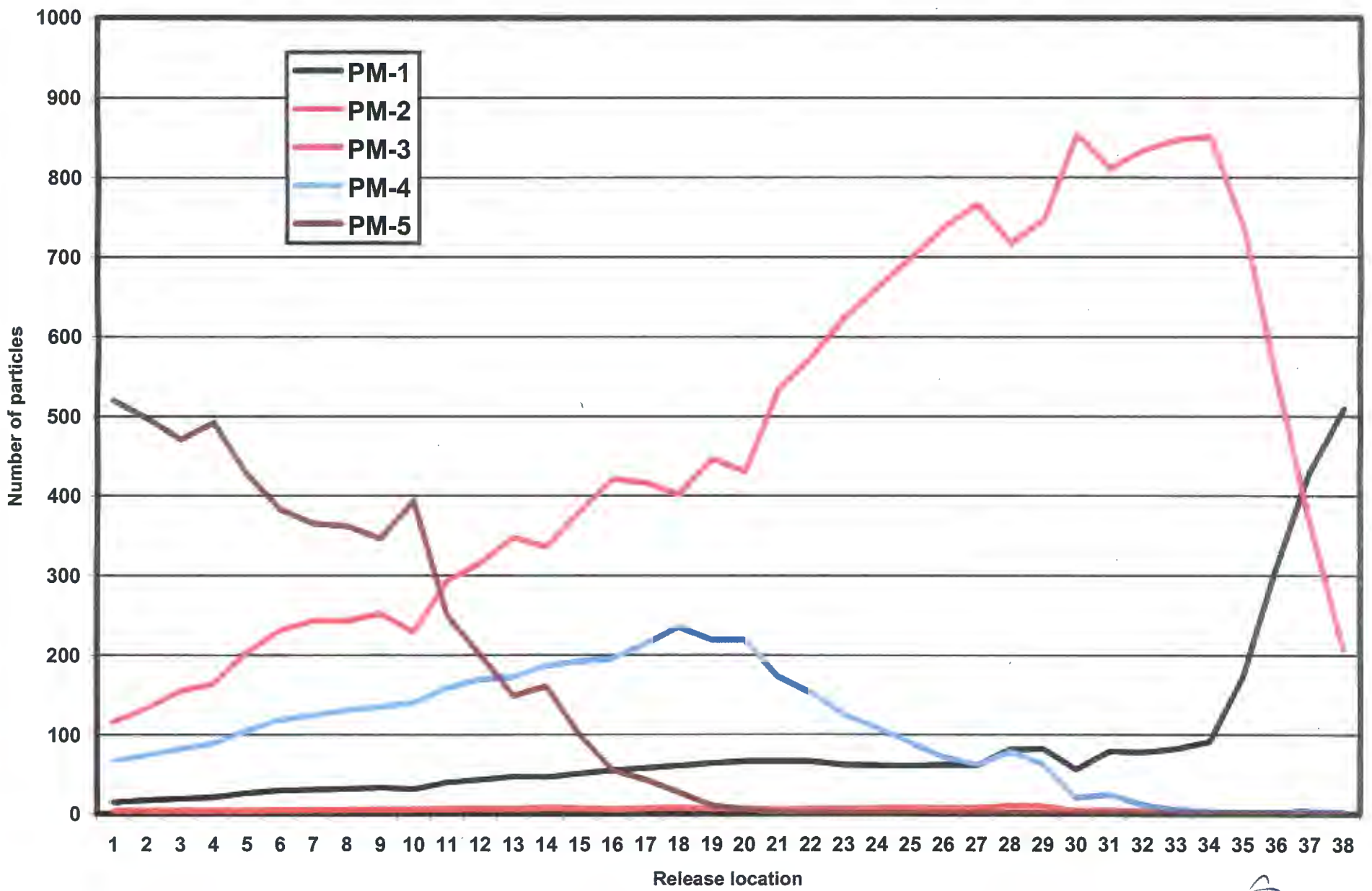

96720 :

# Travel times from the water-table to the water-supply wells

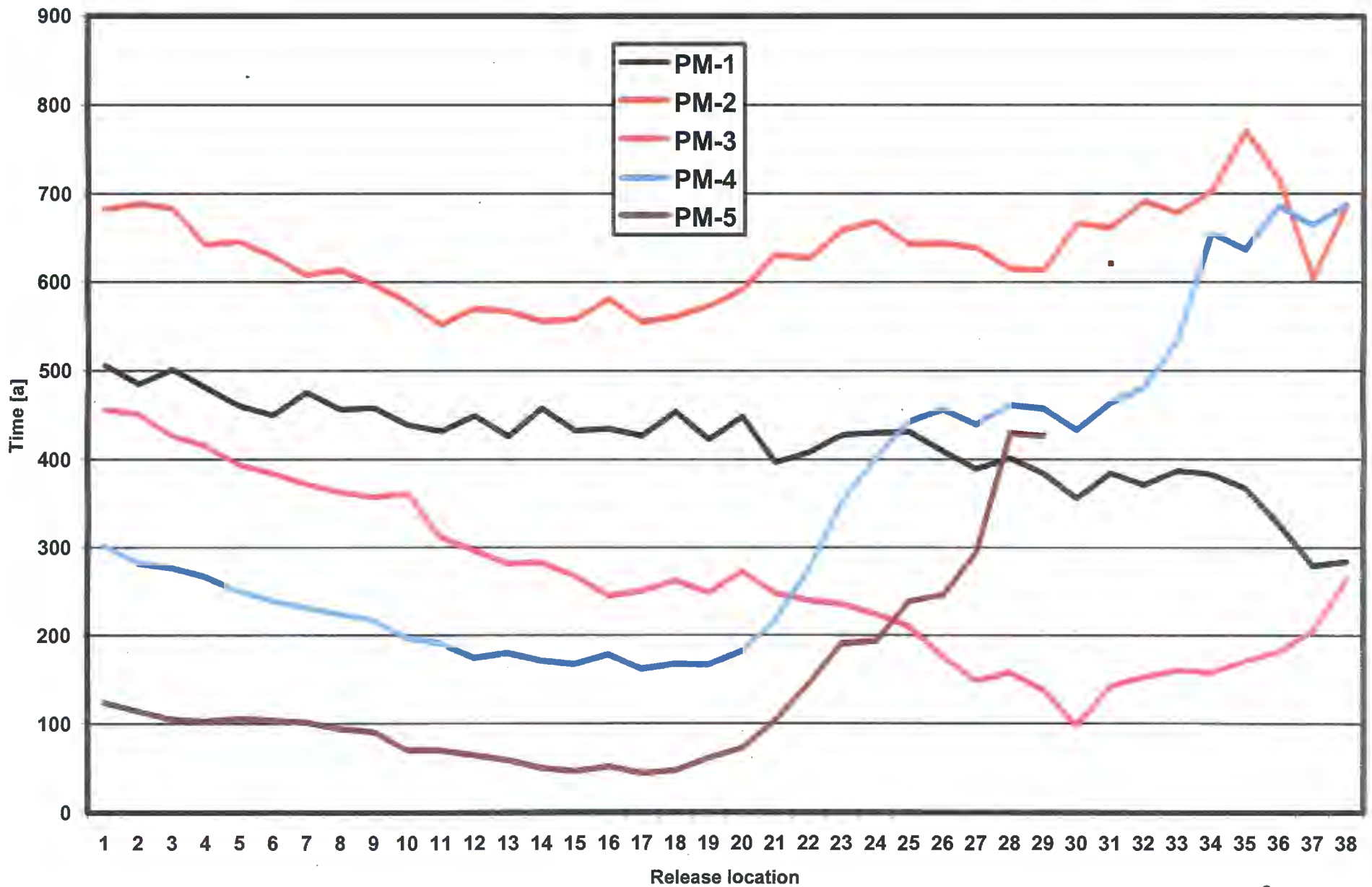

02497

# Portion of contaminant releases captured by PM-1 (including predictive uncertainty)

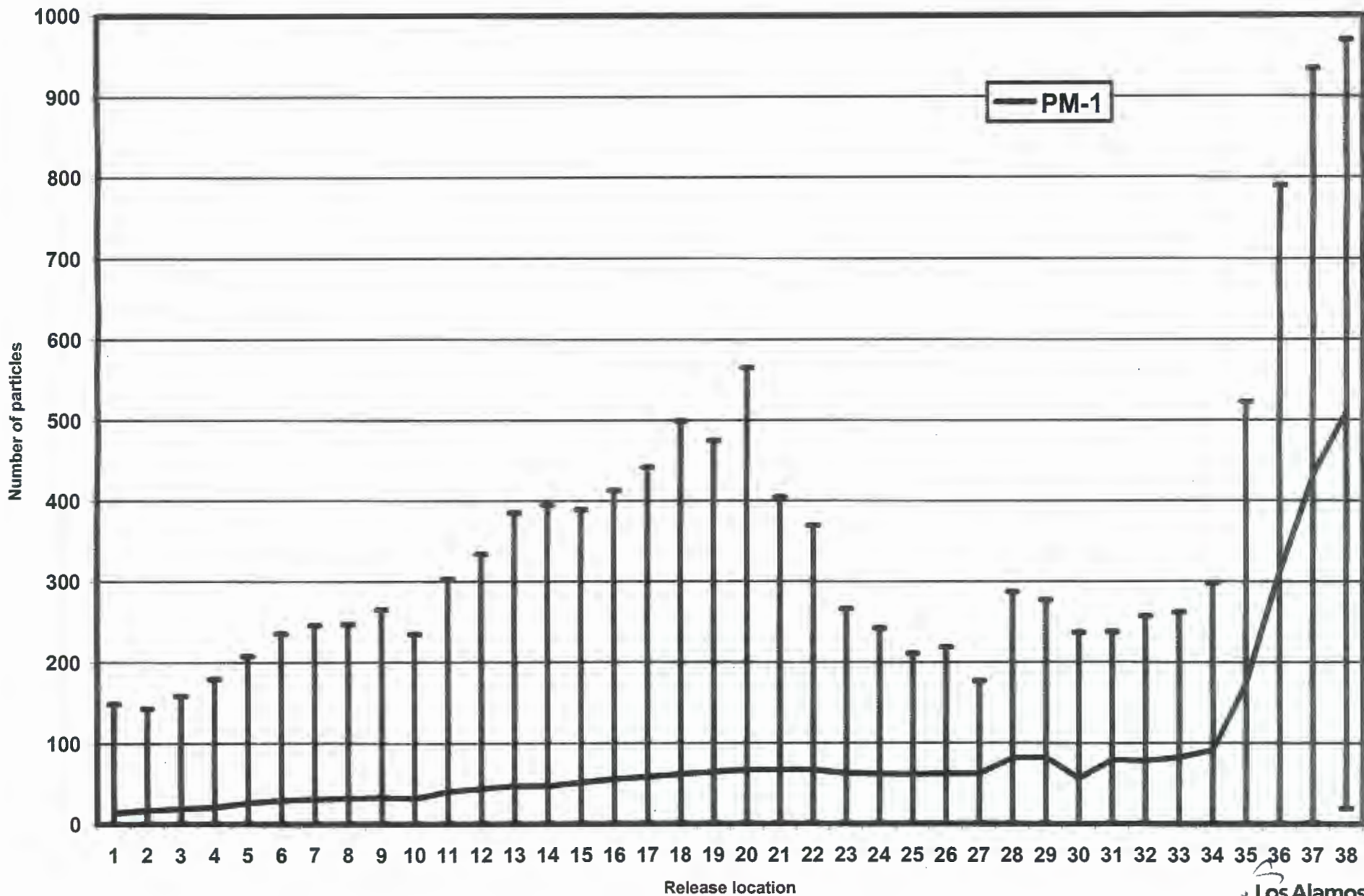

02498

# Portion of contaminant releases captured by PM-2 (including predictive uncertainty)

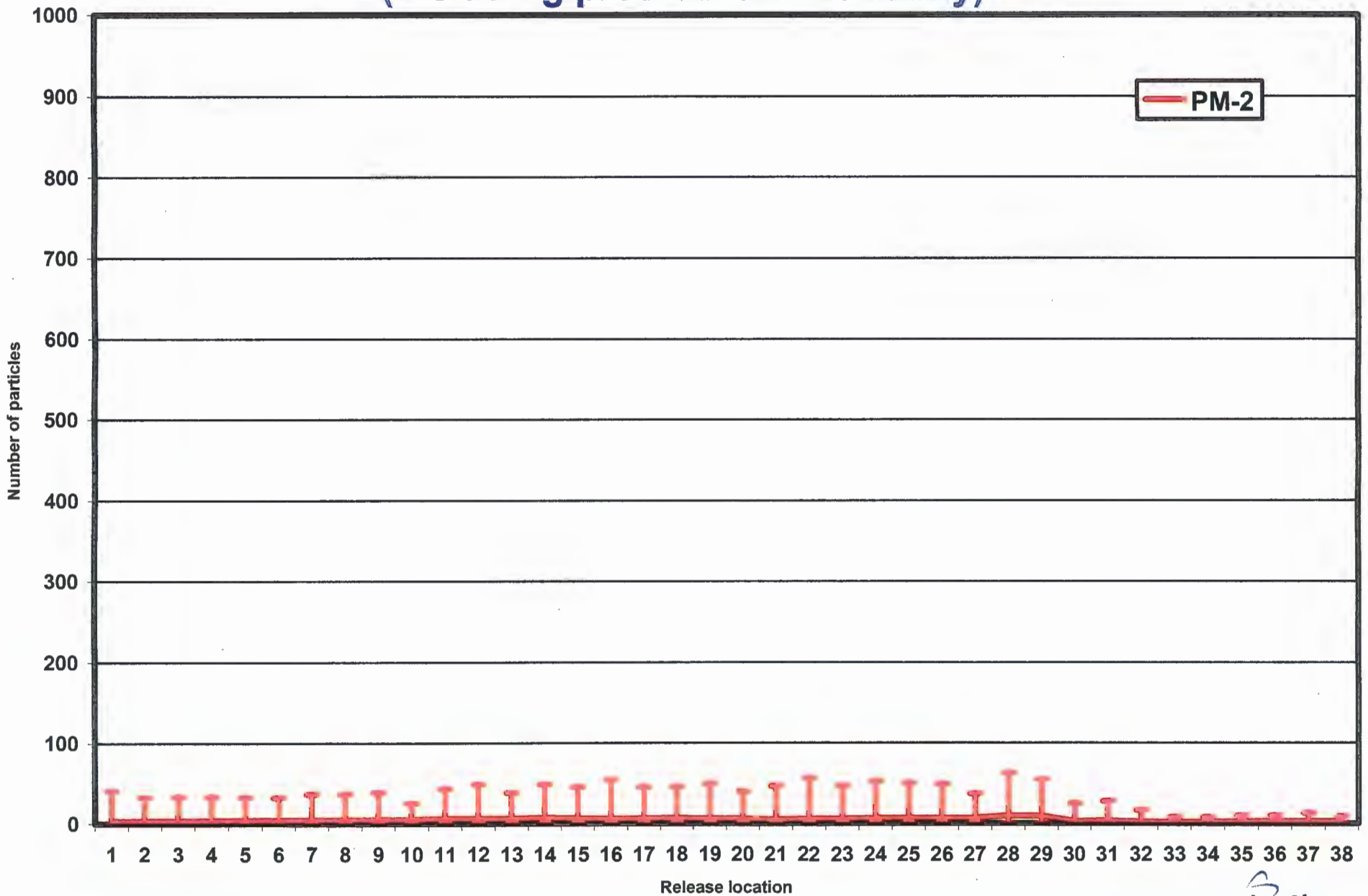

66h20:

## Portion of contaminant releases captured by PM-5 (including predictive uncertainty)

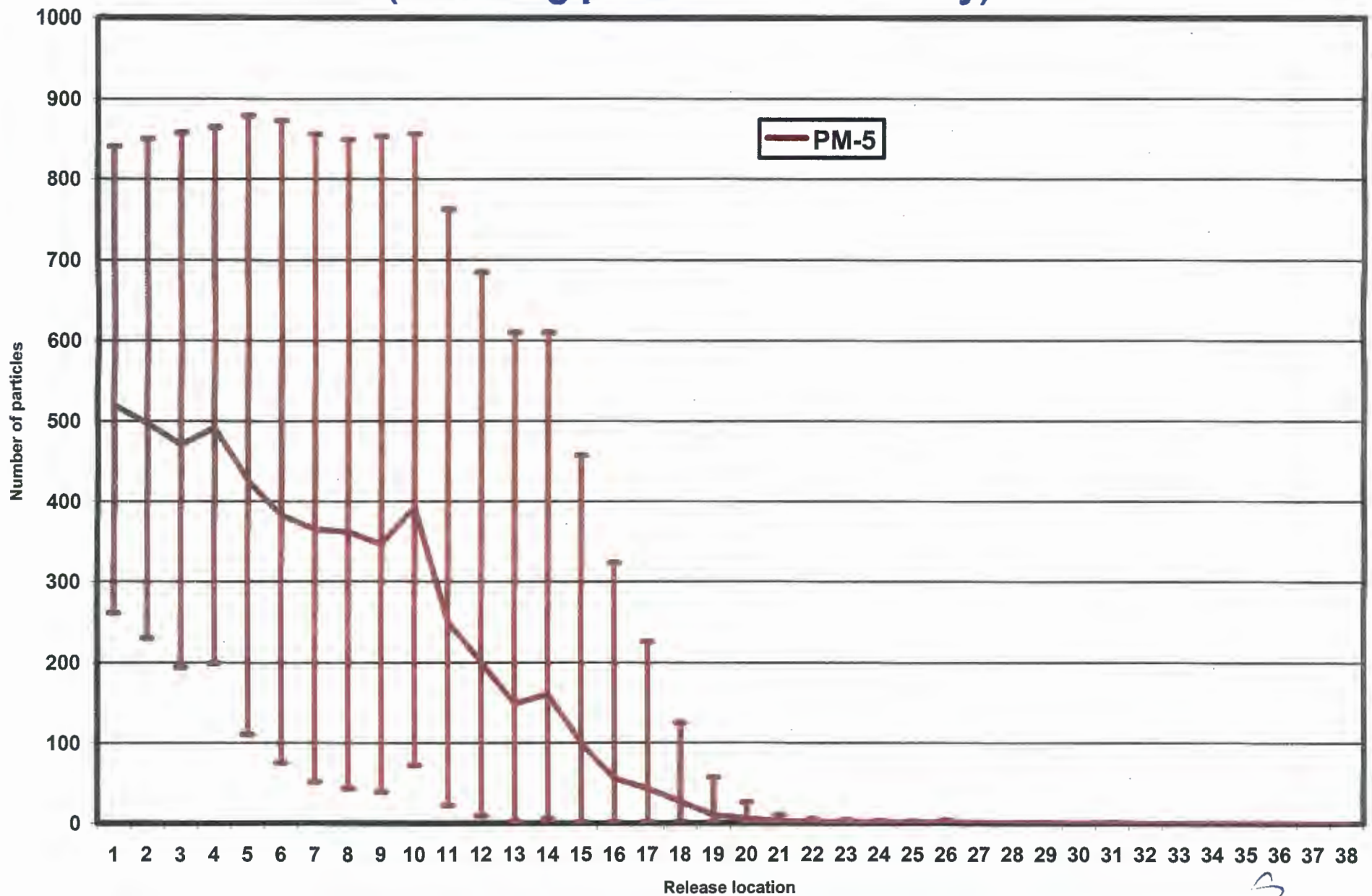

025000

# Travel times from the water-table to PM-4 (including predictive uncertainty)

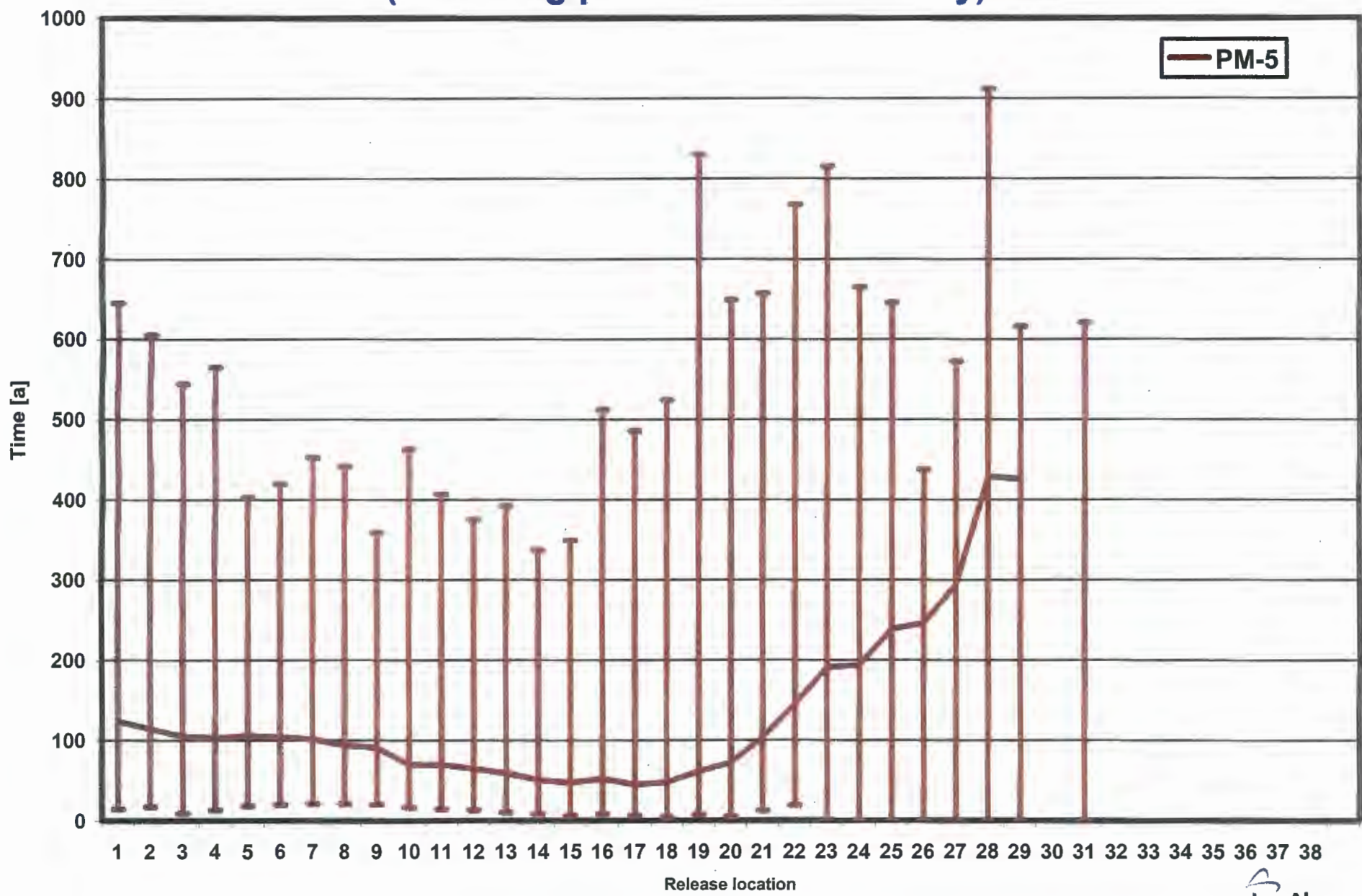

02501

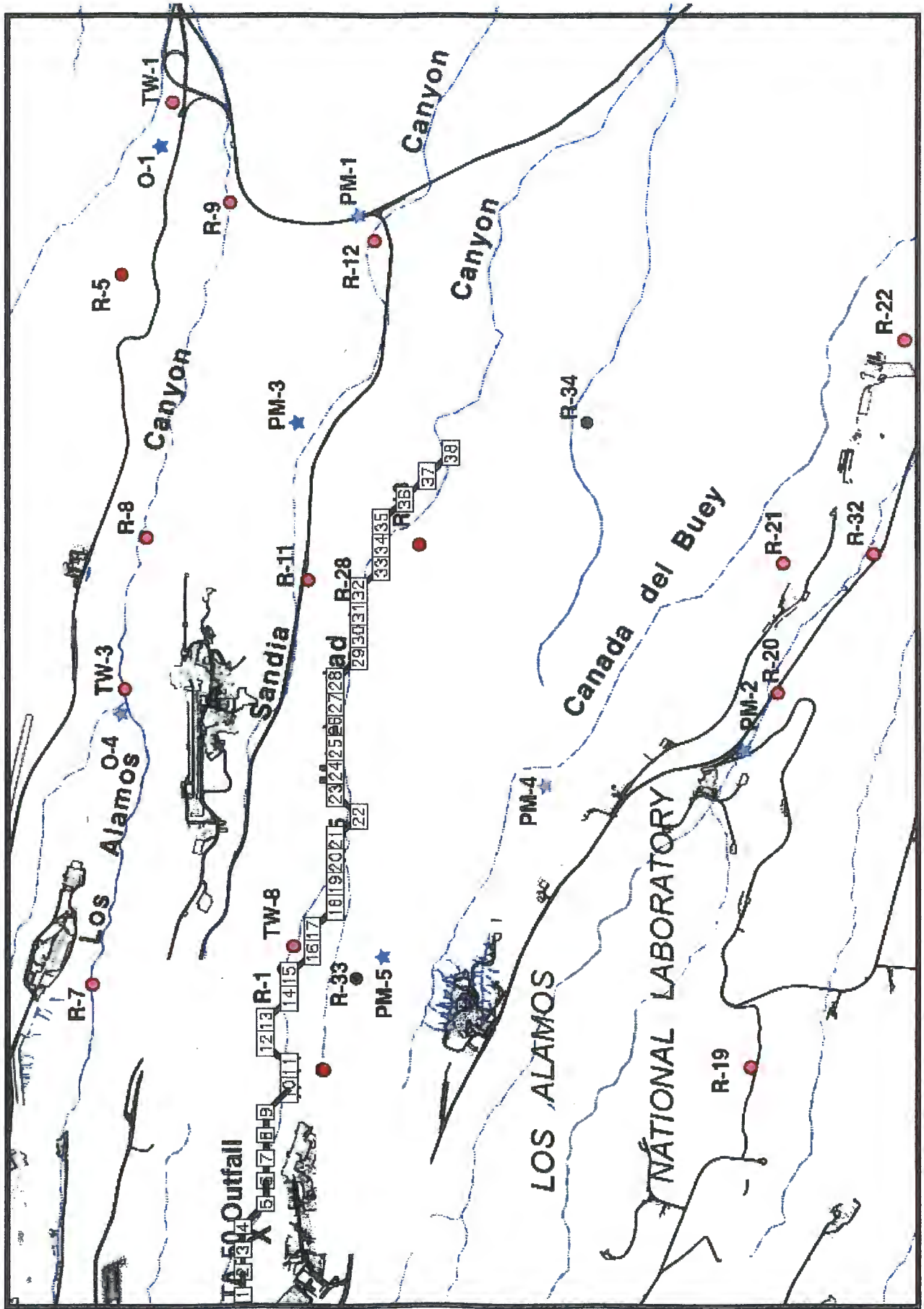

## Findings/Conclusions

- **Unknown future pumping rates has major impact on predicted contaminant pathway**
- **To predict the importance of transients (pumping rates/recharge), it is important to analyze the relation between**
  - ❑ **intensity of the transient stresses (amplitude/frequency of contaminant releases/well pumping),**
  - ❑ **rate of propagation of contaminants (advection/retardation/dispersion)**
  - ❑ **rate of propagation of hydraulic pressures (hydraulic diffusion)**
- **High uncertainty in the contaminant arrivals at the water-table (vadose-zone travel times) is sufficient to preclude accurate predictions of location/time of contaminant capturing at the wells**
- **Mortandad WorkPlan will help to reduce uncertainty in the model predictions**
- **GWPA can be used to evaluate the impact of any new data on the uncertainty in the model predictions**





# Historical Contaminant Impact on Groundwater at LANL

David B. Rogers  
 Groundwater Protection Program  
 Quarterly Meeting  
 July 13, 2004  
 LA-UR-04-4674



The World's Greatest Science Protecting America



## Presentation Outline

- Overview of LANL groundwater contamination:
  - Hydrologic setting and contaminant movement,
  - Contaminant sources,
  - Contaminant levels.
- Major mobile contaminants addressed:
  - Tritium, Strontium-90,
  - Perchlorate, Nitrate,
  - High explosives.
- These contaminants show the maximum extent of groundwater contamination from LANL liquid sources.



The World's Greatest Science Protecting America



## Hydrologic Setting of LANL

- LANL lies on volcanic and sedimentary rocks.
- Unsaturated rock separates the regional aquifer from the surface by 600 to 1200 feet, reducing contaminant movement.

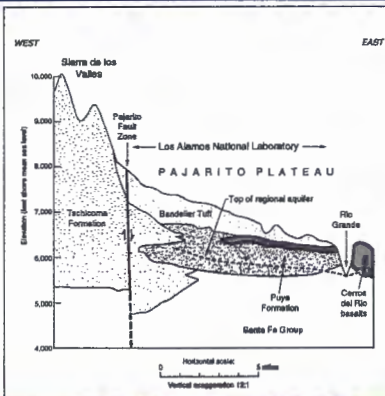

The World's Greatest Science Protecting America



## Three Modes of Groundwater Occurrence at LANL

- (1) perched alluvial groundwater in canyon bottoms,
- (2) zones of intermediate-depth perched groundwater, and
- (3) the regional aquifer beneath the Pajarito Plateau.

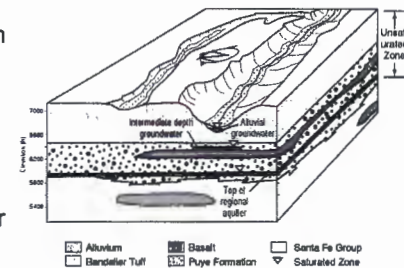

The World's Greatest Science Protecting America



: 02505

## Groundwater Contamination Pathway at LANL

- Since the 1940s, liquid effluent disposal has degraded quality of the alluvial groundwater in some canyons.
- Where Laboratory contaminants are found at depth, large amounts of liquid effluent have been discharged into a canyon (with alluvial groundwater usually present), or onto a mesa-top.

## Groundwater Contamination Pathway at LANL

- Most groundwater impacts are from past effluent releases.
- The Laboratory has eliminated many outfalls and improved the quality of remaining discharges so that they meet applicable standards.

## Contaminant Mobility in Groundwater

- Contaminant mobility is limited by chemical reactions or radioactive decay.
  - Conservative constituents like perchlorate react little and move readily with water.
  - Movement of some constituents like uranium is slowed or their concentrations are decreased by:
    - adsorption or cation exchange,
    - precipitation or dissolution,
    - chemical reactions like oxidation/reduction,
    - radioactive decay.
  - Some constituents like cesium-137 are nearly immobile:
    - strongly adsorbing radionuclides are retained on sediment.

## Contaminant Mobility in Groundwater

<u>Very Mobile</u>	<u>Somewhat Mobile</u>	<u>Nearly Immobile</u>
perchlorate	uranium	americium-241
tritium	strontium-90	plutonium-238
nitrate	barium	plutonium-239
RDX	HE compounds	cesium-137
HMX	solvents	

- Very mobile contaminants show the maximum extent of groundwater contamination from LANL liquid sources.

: 02506

## Major Liquid Release Sources Potentially Affecting Groundwater at LANL

- Most sources shown are inactive.
- Groundwater contaminants reflect the type of effluent source.

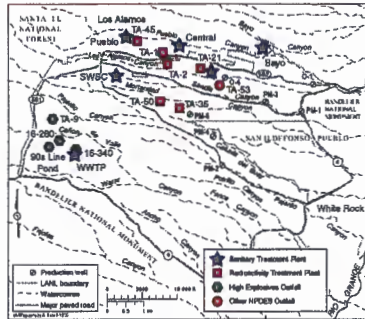

Los Alamos  
NATIONAL LABORATORY  
ESTABLISHED 1947  
The World's Greatest Science Protecting America

NISA

## Relation of Contaminants to Effluent Source at LANL

- Radioactive liquid effluent:
  - Examples:
    - Past: TA-1, TA-45, TA-50 RLWTF, TA-35, TA-21,
    - Present: TA-50 RLWTF.
  - Conservative contaminants move with water:
    - Perchlorate, nitrate, tritium, fluoride.
  - Movement of reactive contaminants is slowed:
    - Strontium-90, uranium.
  - Adsorbing contaminants are retained on sediment:
    - Americium-241, plutonium-238, plutonium-239, -240, cesium-137.

Los Alamos  
NATIONAL LABORATORY  
ESTABLISHED 1947  
The World's Greatest Science Protecting America

NISA

## Relation of Contaminants to Effluent Source at LANL

- Sanitary effluent:
  - Examples:
    - LA County sanitary treatment plants in Pueblo Canyon (only Bayo Sanitary Treatment Plant in operation),
    - LANL Sanitary Wastewater Systems Facility.
  - Conservative contaminants:
    - Nitrate, chloride, boron.
  - Less mobile adsorbing contaminants:
    - Phosphate.

Los Alamos  
NATIONAL LABORATORY  
ESTABLISHED 1947  
The World's Greatest Science Protecting America

NISA

## Relation of Contaminants to Effluent Source at LANL

- High explosives liquid effluent:
  - Examples:
    - TA-16-260, TA-9,
    - Only one outfall in operation: HEWTF.
  - Conservative contaminants:
    - Perchlorate, nitrate, tritium, RDX, HMX.
  - Less mobile reactive contaminants:
    - Ba, some HE compounds,
    - TCE (trichloroethylene), PCE (perchloroethylene).

Los Alamos  
NATIONAL LABORATORY  
ESTABLISHED 1947  
The World's Greatest Science Protecting America

NISA

## Relation of Contaminants to Effluent Source at LANL

- Other NPDES Outfalls:
  - Examples:
    - TA-53 LANSCE.
  - Conservative contaminants:
    - Molybdenum.
  - Decaying contaminants:
    - Short-lived radionuclides (in earlier years).

## Examples of Groundwater Contamination from LANL Effluent Sources

- Perchlorate,
- Nitrate,
- Tritium,
- Strontium-90,
- RDX.

## Perchlorate in Groundwater at LANL

- Map shows perchlorate above 3.7 ppb (EPA Region VI HI = 1).
- Sources are radiochemistry and HE processing effluents.
- O-1 in Pueblo Canyon has 2.8 ppb using LC/MS/MS.

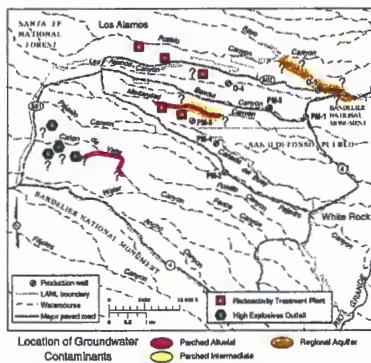

## Perchlorate in Mortandad Canyon

- RLWTF discharges began in 1963.
- Perchlorate in TA-50 effluent undetectable since March 2002.
- Levels in alluvial groundwater are decreasing.
- Intermediate: 142 ppb.
- Regional: 4.8 ppb.

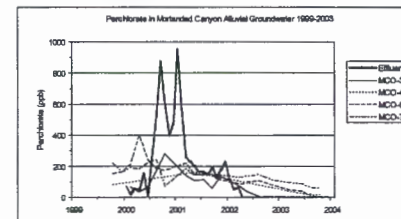

## Perchlorate in Mortandad Canyon

- Water infiltrates through the vadose zone, carrying conservative constituents.
- Core profiles indicate a large inventory of tritium, perchlorate, and nitrate in vadose zone.
- Preliminary estimates suggest 415 to 1250 kg of perchlorate in the upper 300 ft of the vadose zone.

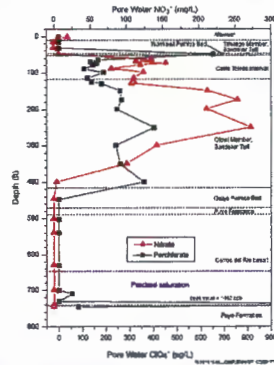

Figure 5-16. Core water nitrate and perchlorate concentrations for borehole 02-03.

Los Alamos  
NATIONAL LABORATORY  
EST. 1947

The World's Greatest Science Protecting America

NISA

## Perchlorate as a Groundwater Contaminant at LANL

- Perchlorate was (probably) discharged in:
  - Acid/Pueblo Canyons:
    - No present source; perchlorate is now seen only in regional aquifer at low concentrations.
  - DP/Los Alamos Canyons:
    - No present source; now seen only in cores below outfall.
  - Mortandad Canyon:
    - No present source; concentrations in alluvium falling; perchlorate is still present in the vadose zone and regional aquifer.
- Perchlorate is rapidly diluted in groundwater having short residence times (higher recharge and flow rates).

Los Alamos  
NATIONAL LABORATORY  
EST. 1947

The World's Greatest Science Protecting America

NISA

## Past Nitrate in Groundwater at LANL

- Map shows inferred past extent of nitrate (as nitrogen) above NM GW standard (10 mg/L).
- Sources are radiochemistry, HE, and sanitary effluents.

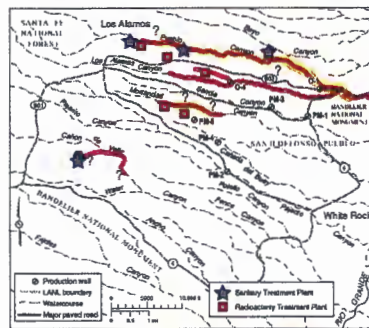

Los Alamos  
NATIONAL LABORATORY  
EST. 1947

The World's Greatest Science Protecting America

NISA

## Nitrate in Groundwater at LANL

- Map shows present nitrate (as nitrogen) above NM GW standard (10 mg/L).
- Source elimination and effluent improvement decreased groundwater nitrate levels.

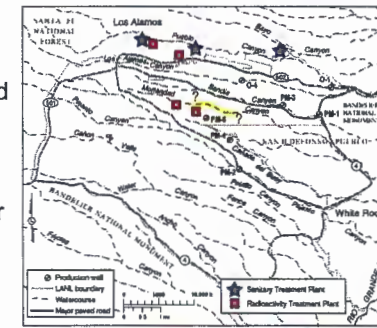

Los Alamos  
NATIONAL LABORATORY  
EST. 1947

The World's Greatest Science Protecting America

NISA

## Nitrate in Pueblo Canyon

- TA-45 discharged from 1943 to 1964.
- LA County operated several sanitary treatment plants- one current plant.
- Intermediate: 4 mg/L ( $\text{NO}_3\text{-N}$ ) in POI-4.
- Regional: 2 mg/L in O-1, 6 mg/L in TW-1.

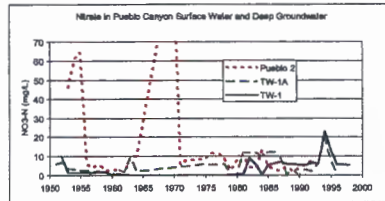

## Nitrate in DP/Los Alamos Canyon

- TA-21 discharged from 1952 to 1986.
- Nitrate levels dropped after 1986.
- Regional: always at background levels.

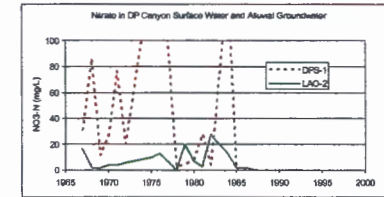

## Nitrate as a Groundwater Contaminant at LANL

- Nitrate was discharged in:
  - Acid/Pueblo Canyons:
    - No present LANL source; continued nitrate presence due to LA County sanitary discharges.
  - DP/Los Alamos Canyons:
    - No present source; concentrations dropped greatly after discharges ceased.
  - Mortandad Canyon:
    - Effluent levels reduced; concentrations in alluvium falling; still present in vadose zone and regional aquifer.
- Nitrate is rapidly diluted in groundwater having short residence times (higher recharge and flow rates).

## Past Tritium in Groundwater at LANL

- Map shows inferred past extent of tritium above 20,000 pCi/L.
- Sources are reactors, radiochemistry effluents.
- No tritium exceeded this level in 2003.
- Source elimination has decreased groundwater tritium levels.

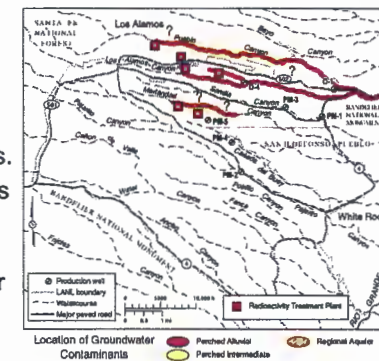

## Tritium in Upper Los Alamos Canyon

- nCi/L = 1000 pCi/L.
- Omega west reactor leaked until 1993.
- Alluvial tritium levels dropped after leak stopped.
- Intermediate: was 5,000 pCi/L, now at background levels.
- Regional: ND to 50 pCi/L in Test Well 3.

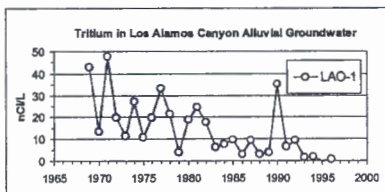

Los Alamos  
NATIONAL LABORATORY

The World's Greatest Science Protecting America

NNSA

## Tritium in DP/Los Alamos Canyon

- TA-21 discharged from 1952 to 1986.
- Tritium in surface water reached 5,000,000 pCi/L or 250 times EPA MCL.
- Intermediate: now 230 pCi/L at R-9i.
- Regional: 24 pCi/L at R-9.

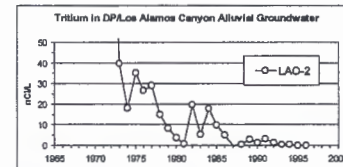
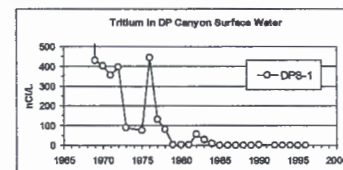

Los Alamos  
NATIONAL LABORATORY

The World's Greatest Science Protecting America

NNSA

## Tritium as a Groundwater Contaminant at LANL

- Tritium was discharged in:
  - Acid/Pueblo Canyons:
    - No present source; tritium is now seen only in intermediate zone and regional aquifer at low activities.
  - DP/Los Alamos Canyons:
    - No present source; activities dropped greatly after discharges ceased.
  - Mortandad Canyon:
    - Effluent levels reduced; activity in alluvium falling; still present in vadose zone and regional aquifer.
- Tritium is rapidly diluted in groundwater having short residence times (higher recharge and flow rates).

Los Alamos  
NATIONAL LABORATORY

The World's Greatest Science Protecting America

NNSA

## Strontium-90 in Groundwater at LANL

- Map shows strontium-90 above 8 pCi/L MCL.
- Sources are radiochemistry effluents.
- Strontium-90 is persistent due to cation exchange.
- No strontium-90 ever consistently detected in deeper groundwater.

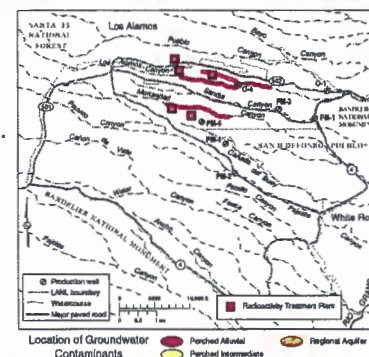

Los Alamos  
NATIONAL LABORATORY

The World's Greatest Science Protecting America

NNSA



## Strontium-90 in Pueblo Canyon

- TA-45 discharged from 1943 to 1964.
- Strontium-90 is now seen at low levels.
- Level in alluvium was 0.5 pCi/L or 6% of the EPA MCL in 2003.

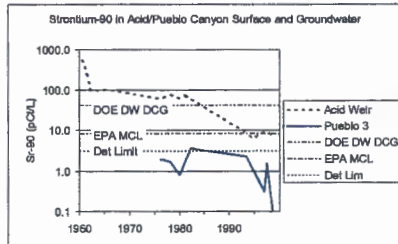

## Strontium-90 in DP/Los Alamos Canyon

- TA-21 discharged from 1952 to 1986.
- Strontium-90 in surface water reached 28,6000 pCi/L.
- The 2003 level in alluvial groundwater was 3.6 times the EPA MCL.
- Downstream values are increasing.

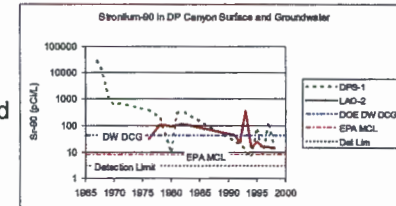

## Strontium-90 as a Groundwater Contaminant at LANL

- Strontium-90 was discharged in:
  - Acid/Pueblo Canyons:
    - Activity once was 500 pCi/L in surface water;
    - No present source; Strontium-90 is now seen only in alluvium at low activities.
  - DP/Los Alamos Canyons:
    - Activity once was 29,000 pCi/L in surface water;
    - No present source; activities dropped greatly after discharges ceased;
    - Strontium-90 persists due to large inventory in alluvial sediment, moves to alluvial groundwater by cation exchange.

## Strontium-90 as a Groundwater Contaminant at LANL

- Strontium-90 was discharged in (continued):
  - Mortandad Canyon:
    - Effluent levels reduced;
    - Strontium-90 persists due to large inventory in alluvial sediment, moves to alluvial groundwater by cation exchange.
- Strontium-90 is relatively immobile in groundwater due to cation exchange with sediments.
- Strontium-90 activity decreases over time due to its 29 yr half-life.

## RDX in Groundwater at LANL

- Map shows RDX above EPA  $10^{-5}$  risk level of 6.1 ppb.
- Sources are High Explosives processing effluents.
- HE outfalls have been eliminated.

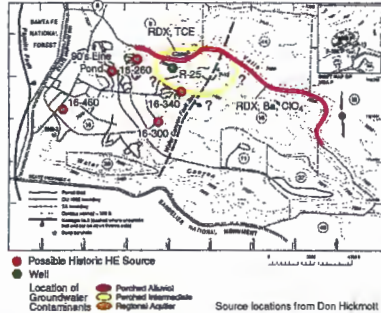

## RDX as a Groundwater Contaminant at LANL

- RDX was discharged in:
  - Cañon de Valle and Water Canyon:
    - Sources have been eliminated;
    - Present in alluvial, intermediate, and regional groundwater zones.
- RDX is very mobile in groundwater.
- RDX should be rapidly diluted in groundwater having short residence times (higher recharge and flow rates).

## Groundwater Contamination at LANL - Conclusion

- Major LANL contaminant impacts on groundwater are due to past large-volume liquid effluent releases.
- Movement of contaminant relates to chemical behavior:
  - Conservative (nonreacting) constituents move farthest:
    - Perchlorate, nitrate, tritium, RDX.
  - Movement of adsorbing or reactive contaminants is slowed:
    - Strontium-90 is partially immobilized by cation exchange;
    - Cesium-137 is nearly completely immobilized by adsorption.
  - Radioactive decay or chemical reactions decrease contaminant concentrations:
    - Tritium.

## Groundwater Contamination at LANL - Conclusion

- Groundwater contamination at LANL:
- Includes recently discharged conservative contaminants that have high risk levels at low concentrations:
    - Perchlorate, RDX.
  - Includes recently discharged solvents which have high risk levels at low concentrations:
    - PERC, TCE.
  - Includes a reactive contaminant with a 29-yr half-life that is nearly fixed in location:
    - Strontium-90.

## Groundwater Contamination at LANL - Conclusion

- Other groundwater contamination at LANL:
  - Includes contaminants whose concentrations have decreased below risk levels when sources are eliminated:
    - Nitrate, tritium, perchlorate (in Pueblo Canyon).
    - Tritium activity is decreased by dilution and radioactive decay.
    - Nitrate and perchlorate concentrations are decreased by dilution.

## Appendix: Additional Data on Groundwater Contamination at LANL

- The following slides show additional data on past nitrate, tritium, and strontium-90 levels in groundwater at LANL.

## Groundwater Contamination Pathway at LANL

- White Rock Canyon springs show no discernable impacts from LANL liquid effluent discharges.
- Observed spring chemistry is explained by other sources:
  - Naturally occurring perchlorate (?),
  - Meteoric tritium,
  - Fallout cesium-137,
  - Effects of cattle grazing,
  - Municipal sanitary effluent discharges- outfalls and lagoons.

## Past Nitrate in Mortandad Canyon

- RLWTF discharges began in 1963.
- Past levels in alluvial groundwater up to 20 times NM GW Std.

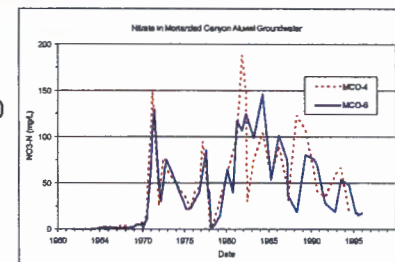

## Recent Nitrate in Mortandad Canyon

- Nitrate in RLWTF effluent is below NM GW standard since April 1999.
- Levels in alluvial groundwater are now below NM GW Std.
- Intermediate: 13.2 mg/L ( $\text{NO}_3\text{-N}$ ).
- Regional: 7.2 mg/L.

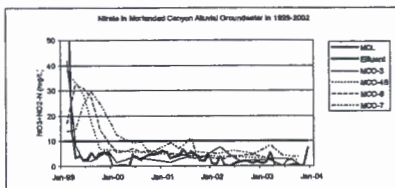

Los Alamos  
NATIONAL LABORATORY

The World's Greatest Science Protecting America

NNSA

## Tritium in Pueblo Canyon

- $\text{nCi/L} = 1000 \text{ pCi/L}$ .
- TA-45 discharged from 1943 to 1964.
- Tritium is now seen at low levels.
- Intermediate: 2,000  $\text{pCi/L}$  in TW-2A.
- Regional: 360  $\text{pCi/L}$  TW-1; 50  $\text{pCi/L}$  in supply well O-1.

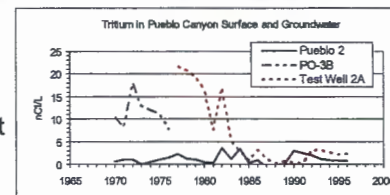

Los Alamos  
NATIONAL LABORATORY

The World's Greatest Science Protecting America

NNSA

## Past Tritium in Mortandad Canyon

- RLWTF discharges began in 1963.
- Past levels in effluent reached 4,700,000  $\text{pCi/L}$  or 235 times the EPA MCL.
- Past levels in alluvial groundwater reached 100 times the EPA MCL.

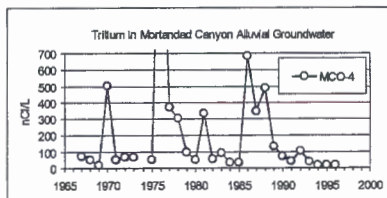

Los Alamos  
NATIONAL LABORATORY

The World's Greatest Science Protecting America

NNSA

## Present Tritium in Mortandad Canyon

- RLWTF tritium has been below the EPA MCL since 2001.
- Levels in alluvial groundwater are now below EPA MCL.
- Intermediate: 15,000  $\text{pCi/L}$ .
- Regional: 15  $\text{pCi/L}$ .

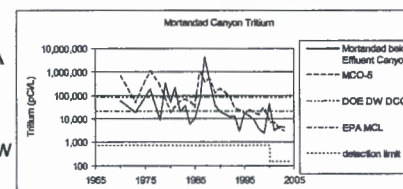

Los Alamos  
NATIONAL LABORATORY

The World's Greatest Science Protecting America

NNSA

## Strontium-90 in Upper Los Alamos Canyon

- Sources are Manhattan Project and reactors.
- Strontium-90 levels in alluvial groundwater have fallen for 30 years.

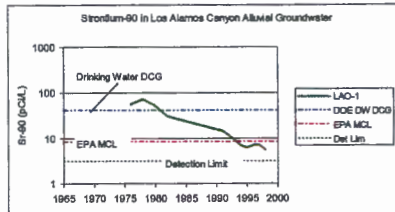

The World's Greatest Science Protecting America



## Strontium-90 in Mortandad Canyon

- RLWTF discharges began in 1963.
- Past levels in effluent reached 1700 pCi/L.
- The 2003 level in alluvial groundwater was 7.8 times the EPA MCL.
- Downstream values are increasing.

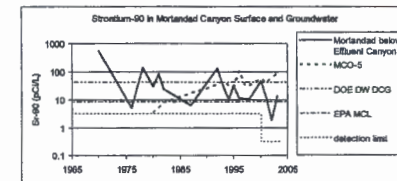

The World's Greatest Science Protecting America



## Historic Flow Rates for Major TA-16 Water Sources (Possible HE Sources)

Site	Flow (Mgal/yr)	Year
▪ TA-16-300	5.3	1994
▪ TA-16-460	3.9	1994
▪ TA-16-340	3.6	1994
▪ TA-16-260	2.5	1994
▪ WW II Area	??	90-s Line Pond

Source: Don Hickmott 11/98



The World's Greatest Science Protecting America



## Possible Historic HE Sources at TA-16

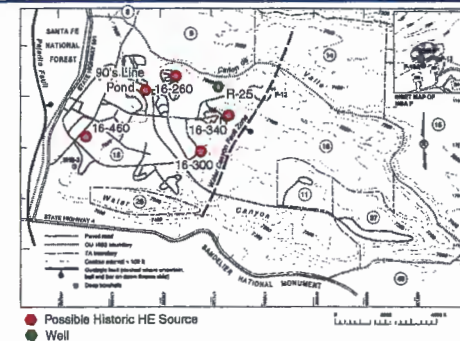

Source locations from Don Hickmott 11/98



The World's Greatest Science Protecting America



### Concentrations of Major TA-16 Contaminants in Alluvial Groundwater

<u>Zone</u>	<u>Constituent</u>	<u>Concentration</u>
▪ Alluvium	Ba	above NM GW Std
▪ Alluvium	ClO <sub>4</sub>	above EPA HI = 1
▪ Alluvium	RDX	above EPA 10 <sup>-5</sup> risk

- EPA Region VI HI = 1 concentration for ClO<sub>4</sub> is 3.7 ppb.
- Risk levels are EPA Region VI excess cancer risk.
- For RDX, 10<sup>-5</sup> risk is 6.1 ppb.

### Concentrations of Major TA-16 Contaminants in Intermediate Perched Groundwater

<u>Zone</u>	<u>Constituent</u>	<u>Concentration</u>
▪ Intermediate	RDX	above EPA 10 <sup>-5</sup> risk
▪ Intermediate	TNT	above EPA 10 <sup>-6</sup> risk
▪ Intermediate	TCE	above EPA 10 <sup>-5</sup> risk
▪ Intermediate	PERC	above EPA 10 <sup>-6</sup> risk
▪ Intermediate	NO <sub>3</sub> -N	above NM GW Std.

- TCE is at 0.5 times the MCL in R-25.
- PERC is at 0.2 times the MCL in R-25.

### Concentrations of Major TA-16 Contaminants in the Regional Aquifer

<u>Zone</u>	<u>Constituent</u>	<u>Concentration</u>
▪ Regional	RDX	above EPA 10 <sup>-6</sup> risk
▪ Regional	TCE	above EPA 10 <sup>-5</sup> risk
▪ Regional	PERC	above EPA 10 <sup>-6</sup> risk

- Presence in regional aquifer uncertain; levels falling rapidly.
- TCE is at 0.2 times the MCL in R-25.
- PERC is at 0.2 times the MCL in R-25.





JUL 30 2004

*Risk Reduction & Environmental Stewardship Division*

P.O. Box 1663, Mail Stop J591  
Los Alamos, New Mexico 87545  
(505) 667-2211/FAX: (505) 665-8190

Date: July 28, 2004  
Refer To: RRES-DO: 04-097

Mr. Curt Frischkorn  
Ground Water Pollution Prevention Section  
Ground Water Quality Bureau  
New Mexico Environment Department  
Harold Runnels Building, Rm. N2250  
1190 St. Francis Drive  
P.O. Box 26110  
Santa Fe, New Mexico 87502

**SUBJECT: TA-50 RADIOACTIVE LIQUID WASTE TREATMENT FACILITY,  
GROUND WATER DISCHARGE PLAN (DP-1132) QUARTERLY REPORT,  
SECOND QUARTER 2004**

Dear Mr. Frischkorn:

This letter is intended to serve as Los Alamos National Laboratory's quarterly Ground Water Discharge Plan (DP-1132) report for the TA-50 Radioactive Liquid Waste Treatment Facility (RLWTF) for the 2<sup>nd</sup> quarter (April, May, June) of 2004. Since the 1<sup>st</sup> quarter of 1999, Los Alamos National Laboratory has provided your agency with voluntary quarterly reports containing analytical results from effluent and ground water monitoring.

Mortandad Canyon Alluvial Ground Water Monitoring Results

Table 1.0 presents the analytical results from sampling conducted at four Mortandad Canyon alluvial monitoring wells during the 2<sup>nd</sup> quarter of 2004. All of the analytical results from MCO-3, MCO-4B, MCO-6, and MCO-7 were below New Mexico Water Quality Control Commission (NM WQCC) Regulation 3103 standards for nitrate-nitrogen (NO<sub>3</sub>-N), fluoride (F), and total dissolved solids (TDS).

RLWTF Effluent Monitoring Results

Table 2.0 presents the analytical results from weekly composite sampling of the RLWTF's effluent. The final weekly composite (FWC) samples are flow-proportioned composite samples prepared from each tank of effluent generated by the RLWTF during a 7-day period. Samples are submitted to General Engineering Laboratories (GEL), Charleston, SC, for analysis. None of the sample results from the 2<sup>nd</sup> quarter exceeded the NM WQCC Regulation 3103 standards for NO<sub>3</sub>-N, F, and TDS.



Table 3.0 presents the final monthly composite (FMC) sample results for nitrates (NO<sub>3</sub>-N) and perchlorate for the 2<sup>nd</sup> quarter of 2004. The FMC samples are flow-proportioned composite samples prepared from each tank of effluent generated by the RLWTF during the month. An internal analytical laboratory located at the TA-50 RLWTF analyzes the samples.

Please contact Bob Beers at (505) 667-7969 if you would like additional information regarding this quarterly report.

Sincerely,



Beverly A. Ramsey  
Division Leader  
Risk Reduction & Environmental Stewardship

BAR:BB/tml

- Cy: M. Leavitt, NMED/SWQB, Santa Fe, NM  
C. Voorhees, NMED/DOE/OB, Santa Fe, NM  
R. Ford-Schmid, NMED/DOE/OB, Santa Fe, NM  
J. Vozella, NNSA/LASO, MS A316  
M. Johansen, NNSA/LASO, MS A316  
G. Turner, NNSA/LASO, MS A316  
S. Gibbs, ADO, MS A104  
T. Stanford, FWO-DO, MS K492  
D. Mclain, FWO-WFM, MS J593  
R. Alexander, FWO-WFM, MS E518  
D. Moss, FWO-WFM, MS E518  
P. Worland, FWO-WFM, MS E518  
K. Hargis, RRES-DO, MS J591  
T. George, RRES-DO, MS J591  
D. Stavert, RRES-EP, MS J591  
C. Nylander, RRES-GP, MS M992  
S. Rae, RRES-WQH, MS K497  
D. Rogers, RRES-WQH, MS K497  
M. Saladen, RRES-WQH, MS K497  
B. Beers, RRES-WQH, MS K497  
RRES-WQH File (04-119), MS K497  
RRES-DO Files, MS J591  
IM-5, MS A150

**Radioactive Liquid Waste Treatment Facility**  
**Ground Water Discharge Plan (DP-1132) Quarterly Report**  
**2nd Quarter, 2004**

**Table 1.0. Mortandad Canyon Alluvial Monitoring Wells Analytical Results.**

Sampling Location	Sample Date	Perchlorate by LC/MS/MS <sup>3</sup> (ug/L)	Perchlorate by IC <sup>4</sup> (ug/L)	NO <sub>3</sub> +NO <sub>2</sub> -N (mg/L)	TKN (mg/L)	NH <sub>3</sub> -N (mg/L)	TDS (mg/L)	F (mg/L)
MCO-3	5/4/2004	4.01	4.03J	1.09	0.47	<0.050	260	0.47
MCO-4B	5/4/2004	37.0	36.8	1.94	0.47	<0.050	293	0.92
MCO-6	5/4/2004	14.2	13.6	1.86	0.41	<0.050	362	1.05
MCO-7	5/4/2004	53.7	52.4	3.99	0.29	<0.050	333	1.07
<i>NM WQCC 3103 Ground Water Standards (mg/L)</i>				<i>10<sup>2</sup></i>			<i>1000</i>	<i>1.6</i>

**Notes:**

<sup>1</sup>NS means that there was not sufficient water available for sampling.

<sup>2</sup>The NMWQCC Regulation 3103 Ground Water Standard is for NO<sub>3</sub>-N.

<sup>3</sup>LC/MS/MS means perchlorate analysis by Liquid Chromatography/Mass Spectrometry/Mass Spectrometry.

<sup>4</sup>IC means the EPA Method 314, perchlorate analysis by Ion Chromatography.

J indicates an estimated value. The result was less than the reporting limit, but greater than the detection limit.

All analyses by General Engineering Laboratories, Charleston, SC.

All samples filtered with the exception of perchlorate.

: 02521

*Radioactive Liquid Waste Treatment Facility  
Ground Water Discharge Plan (DP-1132) Quarterly Report  
2nd Quarter, 2004*

**Table 2.0. RLWTF Final Weekly Composite (FWC) Effluent Monitoring Results, 2nd Quarter, 2004.**

Monitoring Period	Sample Composite Date	RLWTF FWC Results (mg/L)		
		NO <sub>3</sub> +NO <sub>2</sub> -N <sup>1</sup>	Fluoride <sup>1</sup>	TDS <sup>1</sup>
<u>March, 2004</u>	3/28/2004	4.3	0.08J	82
<u>April, 2004</u>	4/5/2004	2.75	0.25	175
	4/12/2004	2.85	0.11	96
	4/19/2004	2.00	0.13	87
	4/26/2004	1.91	0.21	98
<u>May, 2004</u>	5/3/2004	3.30	0.19	134
	5/10/2004	2.50	0.25	221
	5/17/2004	5.40	0.14	192
	5/31/2004	8.5	0.25	189
<u>June, 2004</u>	6/7/2004	9.85	0.20	184
	6/14/2004	7.75	0.14	152
	6/21/2004	pending	pending	pending
	6/28/2004	pending	pending	pending
<b>2nd Quarter 2004 Averages (mg/L)<sup>3</sup></b>		<b>4.65</b>	<b>0.19</b>	<b>146</b>
<i>NM WQCC 3103. Ground Water Standards (mg/L)</i>		<i>10.0<sup>2</sup></i>	<i>1.6</i>	<i>1000</i>

**Notes:**

<sup>1</sup>Analysis by General Engineering Laboratories, Inc., Charleston, SC

<sup>2</sup>The NM WQCC Regulation 3103 Ground Water Standard is for nitrate (NO<sub>3</sub>-N).

<sup>3</sup>2nd quarter averages include results from March 2004.

: 025222

**Radioactive Liquid Waste Treatment Facility**  
**Ground Water Discharge Plan (DP-1132) Quarterly Report**  
**2nd Quarter, 2004**

**Table 3.0. RLWTF Final Monthly Composite (FMC) Effluent Monitoring Analytical Results**

Monitoring Period	Final Monthly Composite (FMC) Analytical Results	
	NO3-N (mg/L)	Perchlorate by IC (mg/L)
April, 2004	0.96 +/-0.1	0 +/- 0.001
May, 2004	4.6 +/-0.5	0 +/- 0.001
June, 2004	3.7 +/-0.7	0 +/- 0.001
<i>NM WQCC 3103. Ground Water Standards</i>	<i>10.0</i>	<i>NA</i>

**Notes:**

All analyses by the Laboratory's TA-50 RLWTF analytical laboratory.

: 02523



---

**Distributions of Nitrate plus Nitrite,  
Perchlorate, RDX, and Tritium within Perched  
Zones and the Regional Aquifer at  
Los Alamos National Laboratory**

**July 13, 2004**

**Patrick Longmire, David Rogers,  
Armand Groffman, David Broxton, and Dale Counce**

02525



GPP-03-



Groundwater  
Protection Program

Slide 1



# Purpose of Presentation

---

- Present recent analytical results for R-wells and
- Perform trend analyses for nitrate plus nitrite, perchlorate, RDX, and tritium at selected R- wells.

## Analytical Methods

---

- ❑ Anions, including nitrate plus nitrite and perchlorate, were analyzed by ion chromatography and/or liquid chromatography-mass spectrometry/mass spectrometry.
- ❑ Tritium was analyzed by electrolytic enrichment and direct counting.
- ❑ High explosive compounds were analyzed by liquid chromatography-mass spectrometry.
- ❑ Other radionuclides were analyzed by gas proportional counting (Sr-90), gamma spectroscopy (Cs-137 and other gamma emitting isotopes), and alpha spectrometry (uranium, plutonium, and americium isotopes).
- ❑ Metals were analyzed by inductively coupled plasma optical emission spectroscopy (ICPOES) and inductively coupled plasma mass spectrometry (ICPMS).

: 02527



GPP-03-



Groundwater  
Protection Program

Slide 3





# Tritium Concentrations at Well R-12

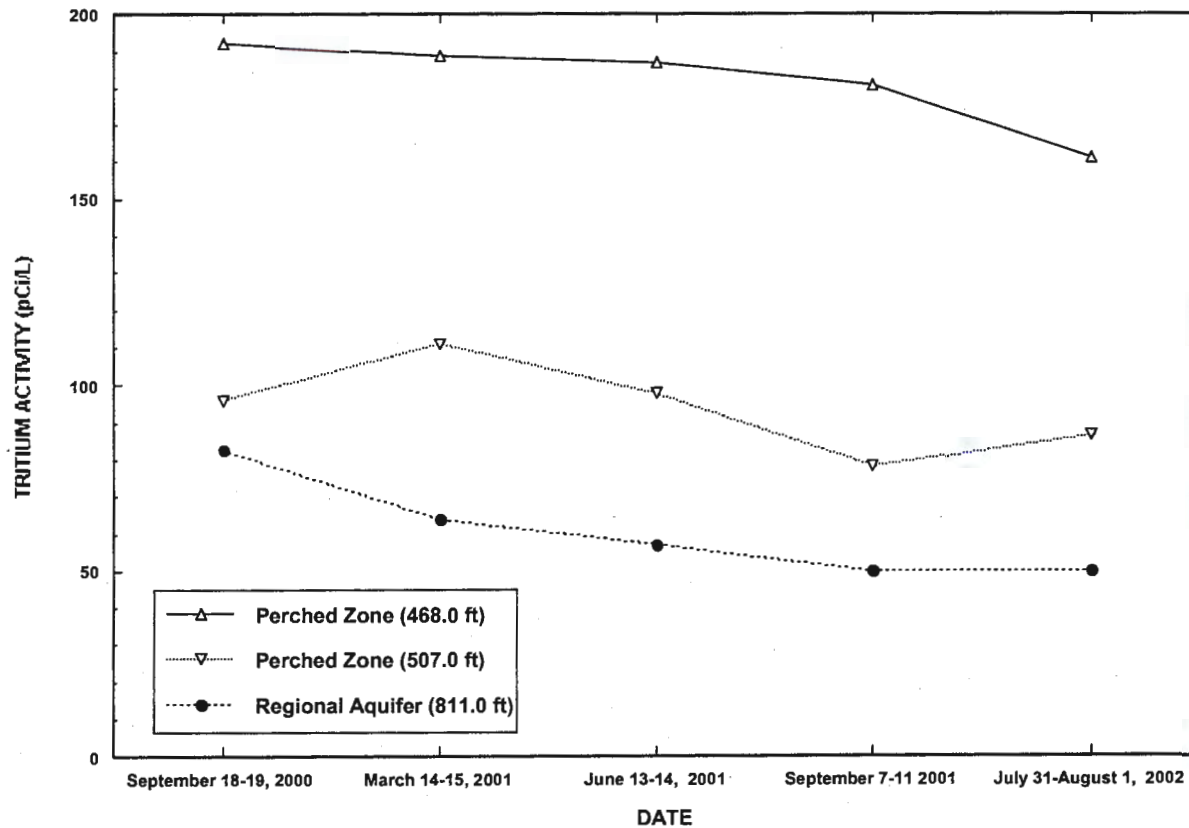

Distribution of tritium in well R-12, upper Sandia Canyon

02528

# Concentrations of Nitrate plus Nitrite, Perchlorate, and Tritium at Well R-15

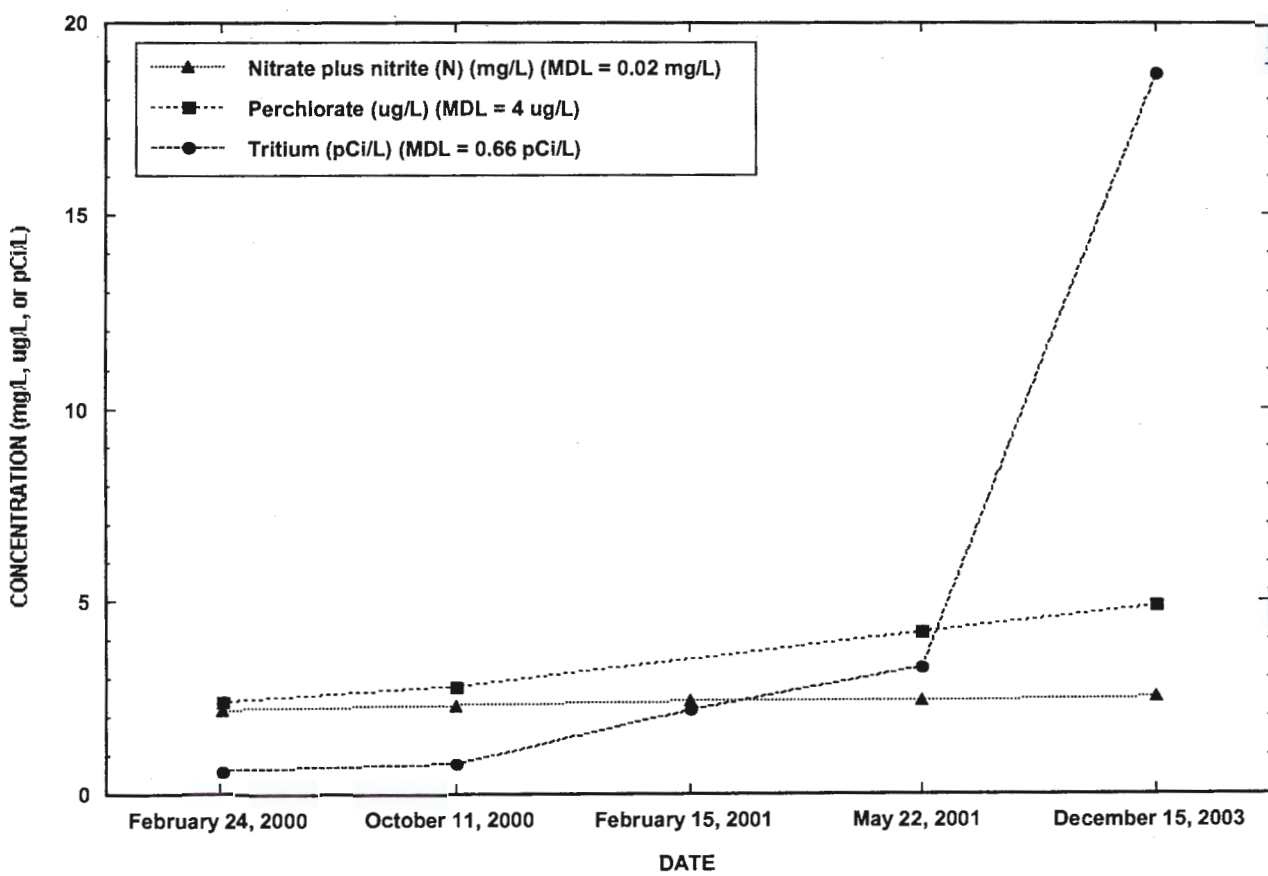

Distributions of nitrate plus nitrite (N), perchlorate, and tritium in well R-15, upper Mortandad Canyon.

025529



GPP-03-



Groundwater Protection Program

Slide 5



# Tritium Concentrations at Well R-22

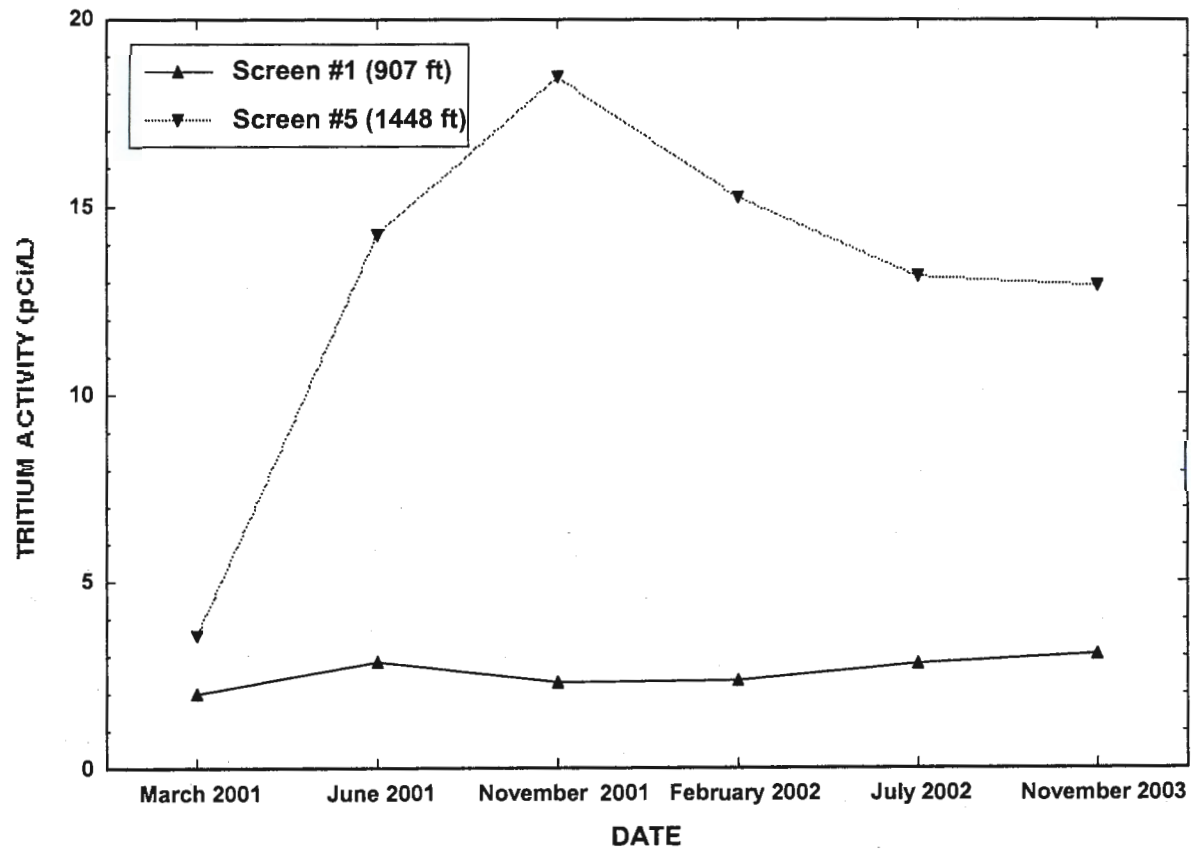

Distribution of tritium at well R-22

# Concentrations of RDX at Well R-25

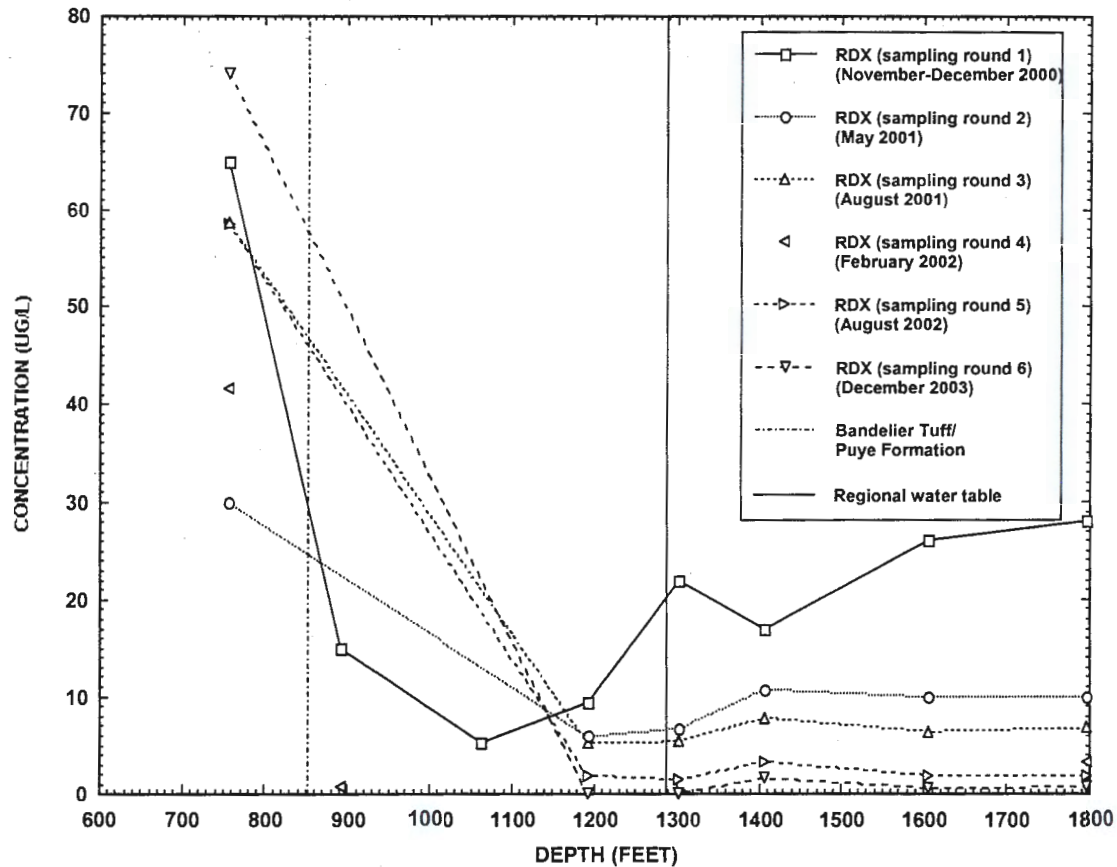

Distributions of RDX observed at well R-25 during six sampling rounds (11/14/00 - 12/11/03)

# Concentrations of Tritium at Well R-25

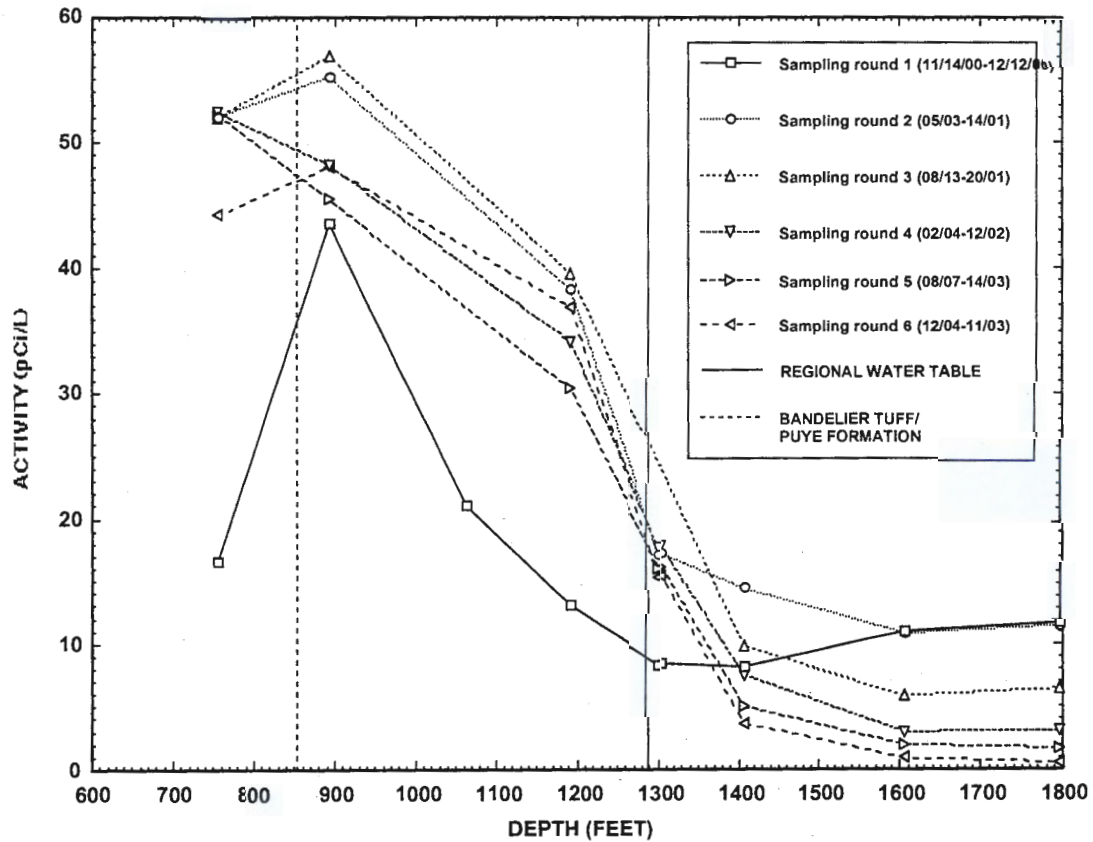

Distribution of tritium during characterization sampling at well R-25

02592

# Conclusions

---

- ❑ Tritium, mostly derived from the Laboratory, has reached perched zones and the regional water table at wells MCOBT-4.4, R-4, R-9i, R-9, R-11, R-12, R-15, R-22, R-25, and R-28. Tritium concentrations are less than 300 pCi/L at these wells, except for MCOBT-4.4 (15,000 pCi/L).
- ❑ Measurable perchlorate, above a baseline of 0.2 to 0.4  $\mu\text{g/L}$ , has reached perched zones and the regional water table at wells MCOBT-4.4, R-5, R-9, R-11, R-15, and R-28. Perchlorate concentrations are less than 5  $\mu\text{g/L}$  at these wells, except at MCOBT-4.4 (179  $\mu\text{g/L}$ ).
- ❑ Nitrate plus nitrite, above a baseline of 0.3 to 0.5 mg/L, has reached perched zones and the regional water table at wells MCOBT-4.4, R-4, R-5, R-9, R-11, R-15, R-19, and R-28. Nitrate plus nitrite concentrations are less than 8 mg/L at these wells, except for MCOBT-4.4 (12.5 mg/L).

02533



GPP-03-



Groundwater  
Protection Program

Slide 9





**Christina Kelso**

---

**From:** Christina Kelso [christina\_kelso@nmenv.state.nm.us]  
**Sent:** Wednesday, August 18, 2004 10:44 AM  
**To:** Robert Beers  
**Subject:** RE: Addresses

Mr. Beers,

Thank you for your assistance. Please let me know Mr. Rae's fax number. The New Mexico Environment Department Ground Water Quality Bureau will fax over the letter requesting the closure plan for TA-50 in addition to mailing this letter.

Christina Kelso

Christina Kelso  
Environmental Scientist  
New Mexico Environment Department  
Ground Water Quality Bureau  
P.O. Box 26110 - Runnels Building  
Santa Fe, NM 87502  
Phone: (505) 827-2782  
Fax: (505) 287-2965  
Email: christina\_kelso@nmenv.state.nm.us

-----Original Message-----

**From:** Robert Beers [mailto:bbeers@lanl.gov]  
**Sent:** Wednesday, August 18, 2004 10:28 AM  
**To:** christina\_kelso@nmenv.state.nm.us  
**Subject:** Addresses

Ms. Kelso---

Here are the addresses you requested:

Steven R. Rae  
Group Leader, Water Quality & Hydrology Group  
Risk Reduction & Environmental Stewardship Division  
MS K497

Dennis G. McLain,  
Facility Manager/Group Leader, Waste Facility Management Group  
Facility & Waste Operations Division  
MS J593

Bob Beers  
Water Quality & Hydrology Group  
Risk Reduction & Environmental Stewardship Division  
MS K497

Please let me know if I can be of additional assistance.



Bob

Bob Beers  
Environmental Surveillance Team  
Water Quality & Hydrology Group  
Los Alamos National Laboratory  
MS K497  
Los Alamos, NM 87545

email: [bbeers@lanl.gov](mailto:bbeers@lanl.gov)  
office: 505-667-7969  
fax: 505-665-9344